

FeedMaster 3600T

Spare Parts Manual

Article number: A143350440
Language: EN
Production year (from): 2011
Prod. Series nr (from): 6631
1366 < Mach. ID <=

FeedMaster 3600T / Table of Contents



PosNo.	Assembly group	Page
B	DRIVE	1
B	ANGULAR GEAR	2
B	SPUR GEAR BOOR	3
B	UNIVERSAL-JOINT SHAFT	4
B	UNIVERSAL-JOINT SHAFT	5
C	TANDEM-BRAKE AXLE (-A 2011)	6
C	BRAKE (-A 2011)	7
C	BRAKE AXLE TANDEM AUTOREVERSE TANDEM.PRESS AIR ()	8
C	TANDEM-WHEEL AXLE HYDRAULIC +501	9
C	ASSEMBLY PENDULAR	10
C	SPRING BORN TANDEM AXLE (8TO.)	11
C	ASSORTMENT OF WHEEL	12
C	BRAKE CABLE TAN. AXLE AUTOREVERSE	13
C	HANDBRAKE TAND AXLE SPR BORN PRESS AIR BRAKE	14
C	HANDBRAKE TAND.AXLE 9TO.2 BRAKES HYDR.	15
C	BRAKE HYDRAULIC (FANCE)	16
C	PARKING STAND (-A 2016)	17
C	PARKING STAND (+A 2017)	18
C	BRAKE AXLE TANDEM HYDRAULIC TRACK 2000 (constructive variant)	19
C	BRAKE AXLE TANDEM HYDRAULIC ()	20
C	BRAKE AXLE TANDEM AUTOREVERSE ()	21
C	BRAKE AXLE TANDEM PRESS AIR ()	22
C	TANDEM-WHEEL AXLE HYDRAULIC ()	23
D	HYDR. BRAKE SYSTEM FOR TANDEM AXLE 2-WHEELS BRAKED	24
D	HYDR. BRAKE SYSTEM FOR TANDEM AXLE 4-WHEELS BRAKED	25
D	COMPRES.AIR SYSTEM SPRUNG TANDEM AXLE_SINGLE AXIS	26
D	COMPRESSED AIR SYSTEM TANDEM AXLE SPRING BORN	27
D	COMPRESSED AIR SYSTEM TANDEM AXLE SPRING BORN	28

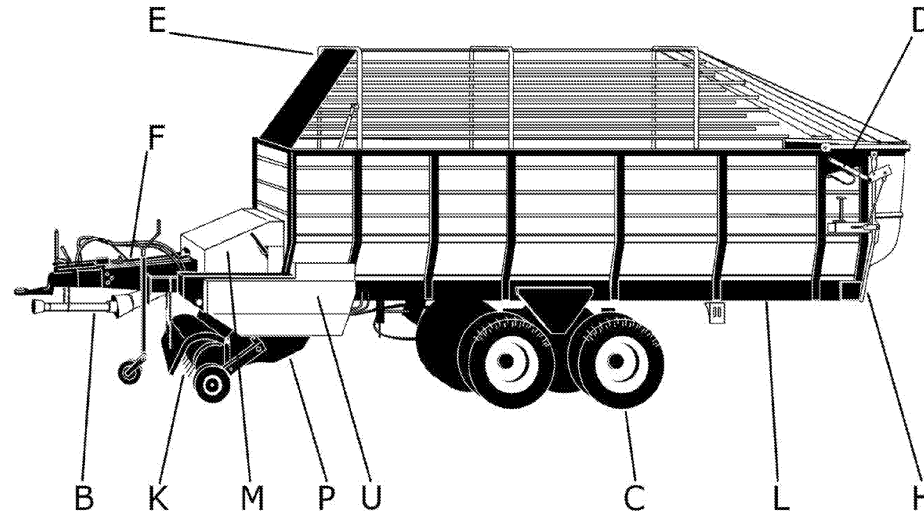

Legende - legend - légende - leyenda

Abkürzungen abbreviation abreviación	Benennung description designación	Englisch	Französisch	Spanisch
K	Grundausstellung, ohne Dosierwalzen	basic equipment, without metering roller	équipement de base, sans cylindre de dosage	equipo básico, sin rodillo dosificación
D	Dosierwalzen Variante	metering roller variant.	variante cylindre de dosage	variantes rodillo dosificación
+	ab (Maschine-Nr.)	from machine number	à partir de machine numéro	a partir de máquina número
-	bis (Maschine-Nr.)	up to machine number	jusqu'à numéro de la machine	hasta máquina número
+A	ab Baujahr	from year of construction	à partir de l'année de construction	desde el año de construcción
-A	bis Baujahr	to year of construction	jusqu'à l'année de construction	hasta el año de construcción
E	ersetzt	replaced	remplacé	sustituye
V	Ausrüstvariante	option	variante	variante
X	gehört zu Pos.Nr.	belongs to pos.no.	fait partie de pos.no.	forma parte de pos.no.
S	siehe Seite	see page	voir page no.	véase en página
b	besteht aus	consist of	se composer de	consistente en

Deutz Fahr

Farb-Nr.-color number-nombre de couleurs-numero de color

end-code	Farbbezeichnung color name-nom couleur-numero del color
A143.....00	no color specification
A143.....80	RAL 6018 Light Green
A143.....86	RAL 7021 Dark Grey
VF.....80	RAL 6018 Light Green
VF.....86	RAL 7021 Dark Grey

FeedMaster 3600T / Table of Contents



PosNo.	Assembly group	Page
D	PRESS.AIR BRAKE WITH AUTOM.LOAD-SENSING VALVE	29
D	HYDR.SCRAPER FLOOR+TAILGATE	30
D	HYDR. INSTALLATION BASIC CONTENT	31
D	HYDR. FOR REAR GATE	32
D	HYDR. FOR PICK-UP	33
D	HYDR. FOR DRY FORAGE SUPERST.	34
D	HYDR. FOR DRY FORAGE SUPERST.	35
D	HYDR. FOR CRANKED DRAWBAR	36
D	HYDR. STEERING	37
D	HYDRAULIC FOR CONVEYOR	38
D	LUBE SYSTEM	39
D	LUBE SYSTEM DRUM WITH 4 RAKES	40
D	LUBE SYSTEM DRUM WITH 6 RAKES	41
D	LUBE SYSTEM DRUM WITH 5 RAKES	42
E	GREEN FODDER SUPERSTRUCTURE SUPPORTS	43
E	GREEN FODDER SUPERSTRUCTURE - SIDE PANELS (-A 2013)	44
E	GREEN FODDER SUPERSTRUCTURE - SIDE PANELS (+A 2014)	45
E	HYDR. ADJUSTEMENT OF BACK NET UNIT	46
E	DRY FORAGE SUPERST. YOKE-PROFILED TUBE	47
E	DRY FORAGE SUPERST. CANVAS AND CABLES	48
E	LEVEL INDICATOR	49
E	RIGID MOUNTING, CANVAS AND CABLES	50
F	FRAME	51
F	DRAWBAR Z 1040	52
F	DRAWBAR Z 450	53
F	OVERR. DRAWBAR	54
F	OVERRUNNING DEVICE (-0700)	55
F	OVERRUNNING DEVICE AVEG 2000 BPW (+0701)	56
F	OVERRUN BRAKE BRAKE LEVER (-0700)	57
F	ADJUSTING SPINDLE	58
H	ELECTR.REMOTE CONTR. PILOTBOX-T	59

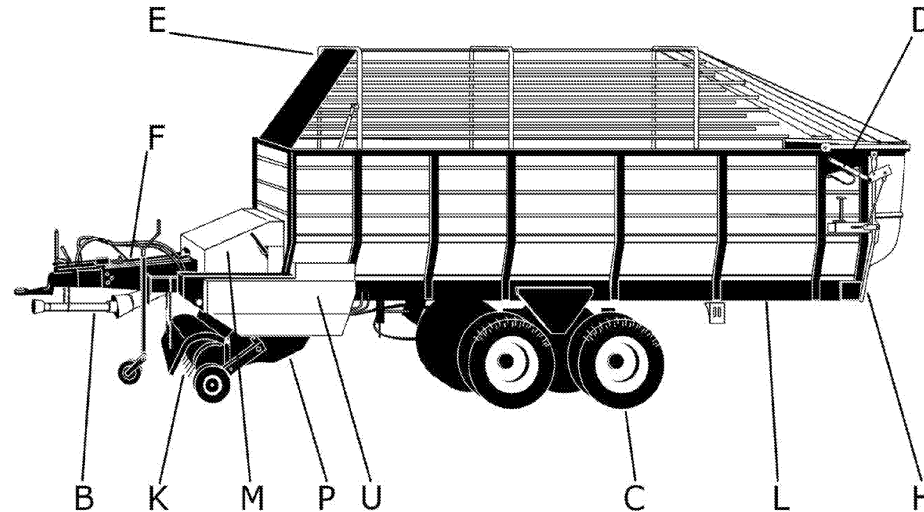

Legende - legend - légende - leyenda

Abkürzungen abbreviation abréviation abreviación	Benennung description désignation denominación	Englisch	Französisch	Spanisch
K	Grundausstattung, ohne Dosierwalzen	basic equipment, without metering roller	équipement de base, sans cylindre de dosage	equipo básico, sin rodillo dosificación
D	Dosierwalzen Variante	metering roller variant	variante cylindre de dosage	variantes rodillo dosificación
+	ab (Maschine-Nr.)	from machine number	à partir de machine numéro	a partir de máquina número
-	bis (Maschine-Nr.)	up to machine number	jusqu'à numéro de la machine	hasta máquina número
+A	ab Baujahr	from year of construction	à partir de l'année de construction	desde el año de construcción
-A	bis Baujahr	to year of construction	jusqu'à l'année de construction	hasta el año de construcción
E	ersetzt	replaced	remplacé	sustituye
V	Ausrüstvariante	option	variante	variante
X	gehört zu Pos.Nr.	belongs to pos.no.	fait partie de pos.no.	forma parte de pos.no.
S	siehe Seite	see page	voir page no.	véase en página
b	besteht aus	consist of	se composer de	consistente en

Deutz Fahr

end-code	Farbbezeichnung color name-nom couleur-nombre del color
A143.....00	no color specification
A143.....80	RAL 6018 Light Green
A143.....86	RAL 7021 Dark Grey
VF.....80	RAL 6018 Light Green
VF.....86	RAL 7021 Dark Grey

FeedMaster 3600T / Table of Contents



PosNo.	Assembly group	Page
H	ELECTR. EQUIPM. DISTRIBUTION BOX	60
H	ELECTR. EQUIPM. LIGHTING	61
H	ELECTR. EQUIPM. BACK NET	62
K	PICK-UP 1.6 SCRAPER	63
K	PICK-UP 1.6 DRUM	64
K	PICK-UP 1.6 BAFFLE PLATE	65
K	PICK-UP 1.6 TACTILE WHEEL	66
K	PICK-UP 1.6 BAFFLE PLATE WITH ROLE	67
K	PICK-UP 1.8 DRUM	68
K	PICK-UP 1.8 DRUM (+A 2004)	69
K	PICK-UP BAFFLE-PLATE	70
K	PICK-UP SCAPPER	71
K	PICK-UP 1.8 TACTILE WHEEL	72
K	PICK-UP 1.8 BAFFLE PLATE WITH ROLE	73
L	SCRAPER FLOOR BOARDS	74
L	SCRAPER FLOOR	75
L	DRUM ELEVATOR GRATE 4 RAKE	76
L	DRUM ELEVATOR GRATE 6 RAKE	77
L	DRUM ELEVATOR GRATE 5 RAKE	78
L	DRUM ELEVATOR SIDE MEM. A. COV .SHEET	79
L	DRUM ELEVATOR DRUM 4- RAKE	80
L	DRUM ELEVATOR DRUM 6 RAKE	81
L	DRUM ELEVATOR DRUM 5 RAKE	82
L	DRUM ELEVATOR CRANK WITH BEARING 4-RAKE	83
L	DRUM ELEVATOR CRANK WITH BEARING 6-RAKE	84
L	DRUM ELEVATOR CRANK WITH BEARING 5-RAKE	85
L	DRUM ELEVATOR PINION SHAFT	86
L	DRUM ELEVATOR RELEASE LEVER	87
M	PROT.HOOD	88
M	MUDGUARD SMALL TANDEM AXLE	89
M	MUDGUARD BROAD TANDEM AXLE	90
P	CUTTING DEVICE	91
P	DOUBLE-CHOPM EQUIPERN.	92
U	INSTRUMENT BOARD FOR TÉLÉ	93

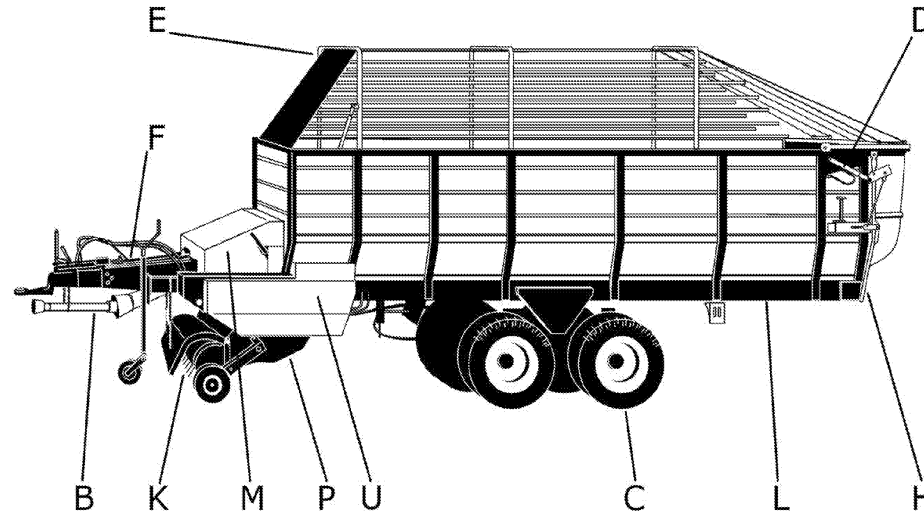

Legende - legend - légende - leyenda

Abkürzungen abbreviation abreviación	Benennung description designaton denominacion	Englisch	Französisch	Spanisch
K	Grundausstellung, ohne Dosierwalzen	basic equipment, without metering roller	Équipement de base, sans cylindre de dosage	equipo básico, sin rodillo dosificación
D	Dosierwalzen Variante	metering roller variant.	variante cylindre de dosage	variantes rodillo dosificación
+	ab (Maschine-Nr.)	from machine number	à partir de machine numéro	a partir de máquina número
-	bis (Maschine-Nr.)	up to machine number	jusqu à numéro de la machine	hasta máquina número
+A	ab Baujahr	from year of construction	à partir de l'année de construction	desde el año de construcción
-A	bis Baujahr	to year of construction	jusqu à l'année de construction	hasta el año de construcción
E	ersetzt	replaced	remplacé	sustituye
V	Ausrüstvariante	option	variante	variante
X	gehört zu Pos.Nr.	belongs to pos.no.	fait partie de pos.no.	forma parte de pos.no.
S	siehe Seite	see page	voir page no.	véase en página
b	besteht aus	consist of	se composer de	consistente en

Deutz Fahr

Farb-Nr.-color number-nombre de couleurs-numero de color

end-code	Farbbezeichnung color name-nom couleur-nombre del color
A143.....00	no color specification
A143.....80	RAL 6018 Light Green
A143.....86	RAL 7021 Dark Grey
VF.....80	RAL 6018 Light Green
VF.....86	RAL 7021 Dark Grey

FeedMaster 3600T / Table of Contents



PosNo.	Assembly group	Page
	COMMAND.	
U	WARNING DECAL EU	94
U	DECALS	95

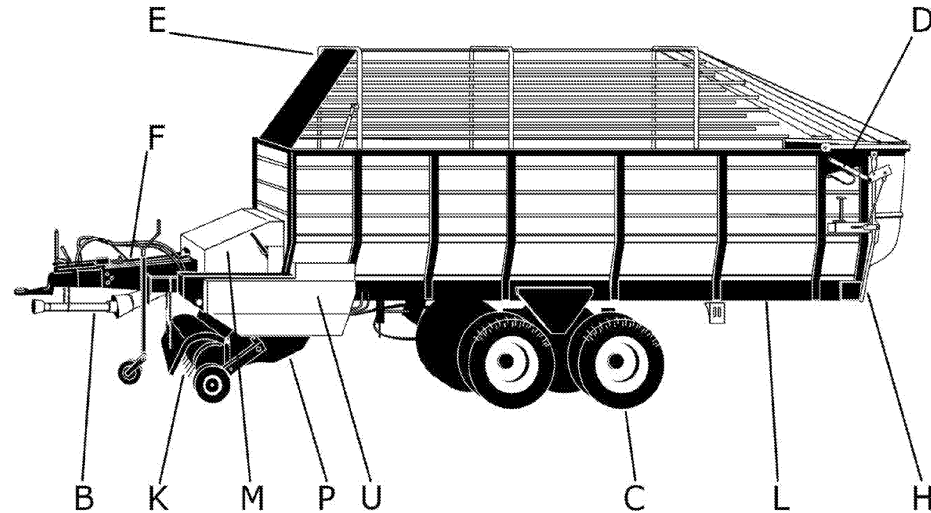

Legende - legend - légende - leyenda

Abkürzungen abbreviation abréviation abreviación	Benennung description désignation denominación	Englisch	Französisch	Spanisch
K	Grundausstellung, ohne Dosierwalzen	basic equipment, without metering roller	équipement de base, sans cylindre de dosage	equipo básico, sin rodillo dosificación
D	Dosierwalzen Variante	metering roller variant	variante cylindre de dosage	variantes rodillo dosificación
+	ab (Maschine-Nr.)	from machine number	à partir de machine numéro	a partir de máquina número
-	bis (Maschine-Nr.)	up to machine number	jusqu'à numéro de la machine	hasta máquina número
+A	ab Baujahr	from year of construction	à partir de l'année de construction	desde el año de construcción
-A	bis Baujahr	to year of construction	jusqu'à l'année de construction	hasta el año de construcción
E	ersetzt	replaced	remplacé	sustituye
V	Ausrüstvariante	option	variante	variante
X	gehört zu Pos.Nr.	belongs to pos.no.	fait partie de pos.no.	forma parte de pos.no.
S	siehe Seite	see page	voir page no.	véase en página
b	besteht aus	consist of	se composer de	consistente en

Deutz Fahr

Farb-Nr.-color number-nombre de couleurs-numero de color

end-code	Farbbezeichnung color name-nom couleur-nombre del color
A143.....00	no color specification
A143.....80	RAL 6018 Light Green
A143.....86	RAL 7021 Dark Grey
VF.....80	RAL 6018 Light Green
VF.....86	RAL 7021 Dark Grey

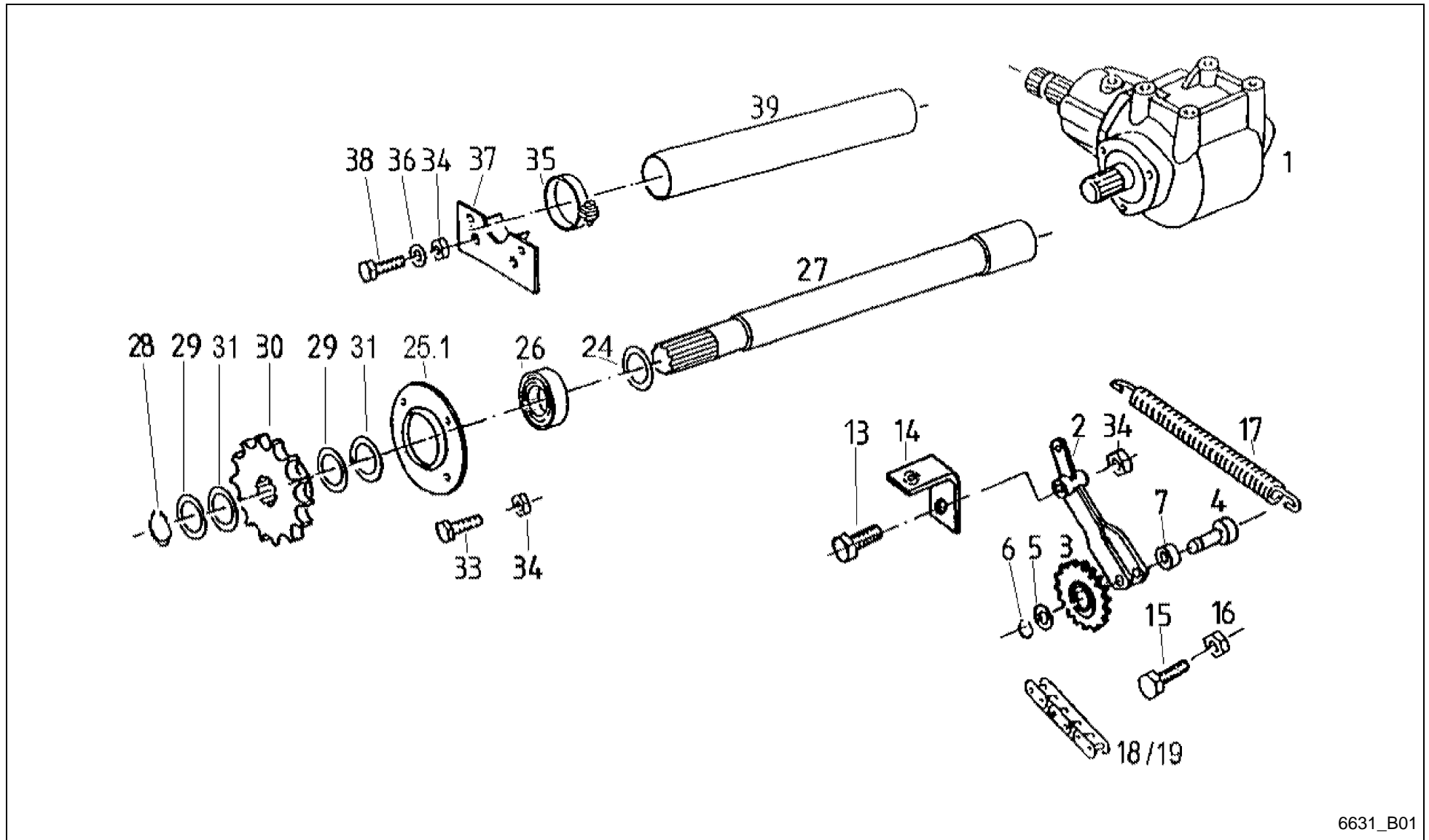

6631_B01

FeedMaster 3600T / DRIVE



PosNo.	Part No.	Qty.	Description	Remark
1	VF06575231	1	ANGLE DRIVE	=> B02a bis 1999
1.1	VF16610801	1	ANGLE DRIVE	=> B02 ab 2000
2	VF16516640	1	TENSIONER	ersetzbar durch Pos.2.1
2.1	VF16631263	1	TENSIONER	ab Y 2006
3	VF16513217	1	SPROCKET	
4	VF16630655	1	BOLT WELDED	
5	VF06214588	1	SHIM	
6	VF01107737	1	CIRCLIP	
7	VF06580174	2	SPACER	
13	VF16610895	1	HEX.BOLT	
14	VF16518921	1	ANGLE PLATE	
15	KG00480461	1	HEX. SCREW M16X50 8.8	
16	VF01112886	1	HEX. NUT	
17	VF01142492	1	DRAW SPRING	
18	VF01142993.01	1	ROLLER CHAIN	bei Kupplungsnahe 28z
19	VF16630157	1	ROLLER CAIN	bei Kupplungsnahe 25z nur noch Ersatz!
24	VF16631182	1	SPACER	
25.1	VF16631815	1	FLANGED SLEEVE CASE	
26	VF16614169	1	BALL BEARING	
27	VF16513000	1	DRIVE SHAFT	
28	VF01107755	1	CIRCLIP	
29	VF01137379	6	SHIM 40 X 50 X 2,5 D988-2	
30	VF16513003	1	SPROCKET	
31	VF06214493	3	SPACER 40X50X1 D988	
33	VF01112529	2	HEX.HEAD SCREW	
34	VF06209769	4	LOCK NUT	
35	VF01128272	1	HOSE CLIP	
36	VF06214207	2	WASHER	
37	VF06550405	1	SUPPORT PLATE	
38	VF01112538	2	HEX.HEAD SCREW	
39	VF06556888	1	PROTECTING TUBE	

FeedMaster 3600T / ANGULAR GEAR

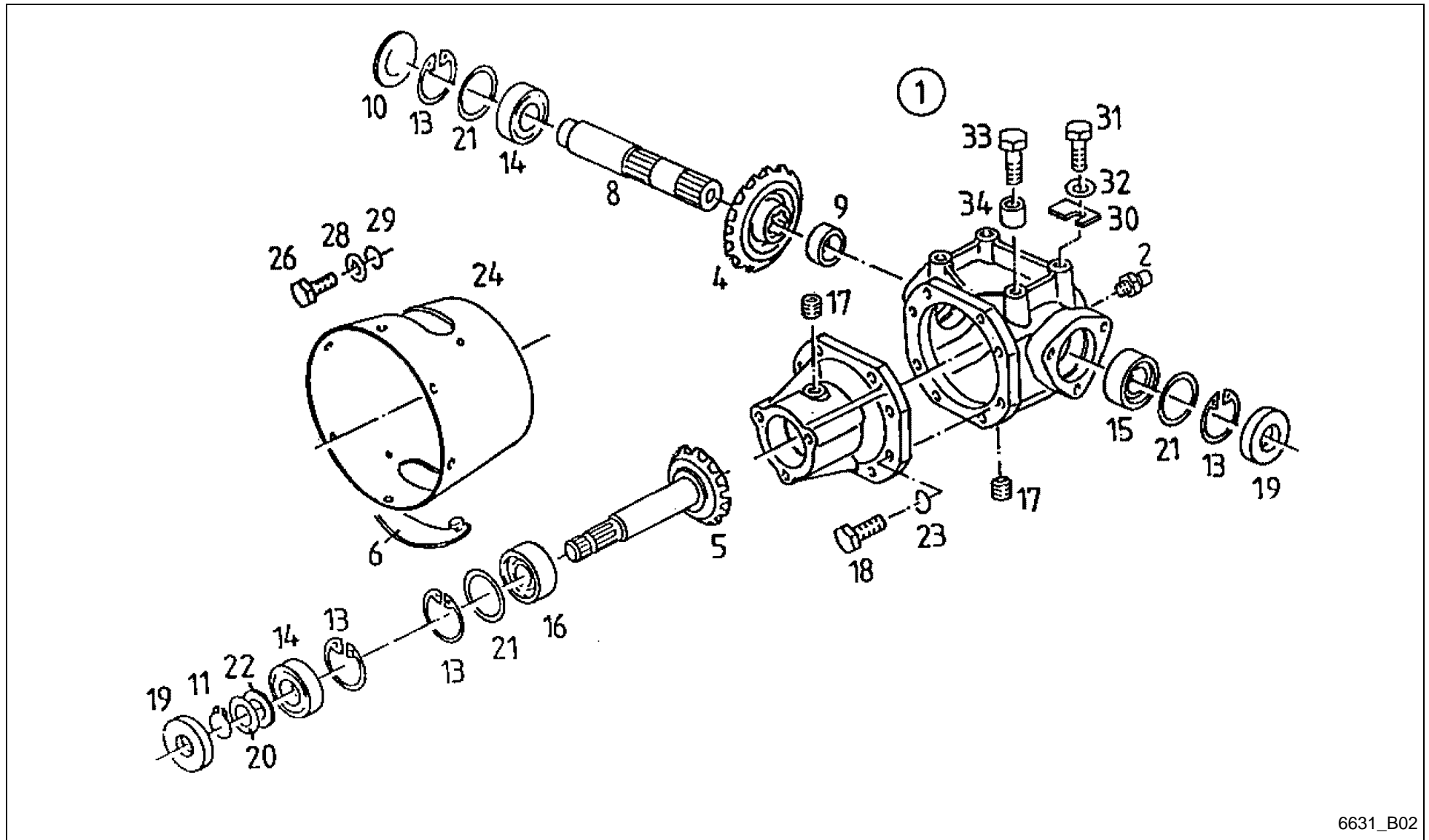

6631_B02

FeedMaster 3600T / ANGULAR GEAR



PosNo.	Part No.	Qty.	Description	Remark
1	VF16610801	1	ANGLE DRIVE	
2	VF06585321	1	VENTING SCREW	
4	VF16611262	1	BEVEL GEAR	
5	VF16611261	1	PINION SHAFT	
6	VF06554188	2	COVER	
8	VF06295430	1	OUTPUT SHAFT	
9	VF11439109110	1	BUSH	
10	VF06557587	1	CAP	
11	VF01137321	1	RING	
13	VF01107855	4	CIRCLIP	
14	VF01109063	2	GROOVE BALL BEARING	
15	VF01109958	1	TAPER R. BEARING	
16	VF01110002	1	TAPER R. BEARING	
17	VF01110415	3	SCREW PLUG	
18	VF01112429	8	HEX. HEAD SCREW	
19	VF01172407	2	RAD.SEAL RING	
20	VF06214490		SPACER	
20	VF06214491		SPACER	
20	VF06214492		SPACER 40X50X0,5 D988	
20	VF01137379		SHIM 40 X 50 X 2,5 D988-2	
21	VF06214521		SPACER	
21	VF06214520		SPACER	
21	VF06214519		SPACER	
23	VF01102800	8	SPRING WASHER	
24	VF06578978	1	PROTECTING CUP	
26	VF01112307	3	HEX. HEAD SCREW	
28	VF06214246	3	WASHER 9X18X2 GALV.	
29	VF01102799	3	SPRING WASHER	
30	VF06575248		SPACER / SHIM	
30	VF06575249		SPACER / SHIM	
30	VF06575250		SPACER / SHIM	
31	VF01177810	2	HEX.BOLT	
32	VF01142556	4	SPACING RING	
33	VF01177888	2	HEX.BOLT	
34	VF06575227	2	SPACER RING	

FeedMaster 3600T / SPUR GEAR BOOR

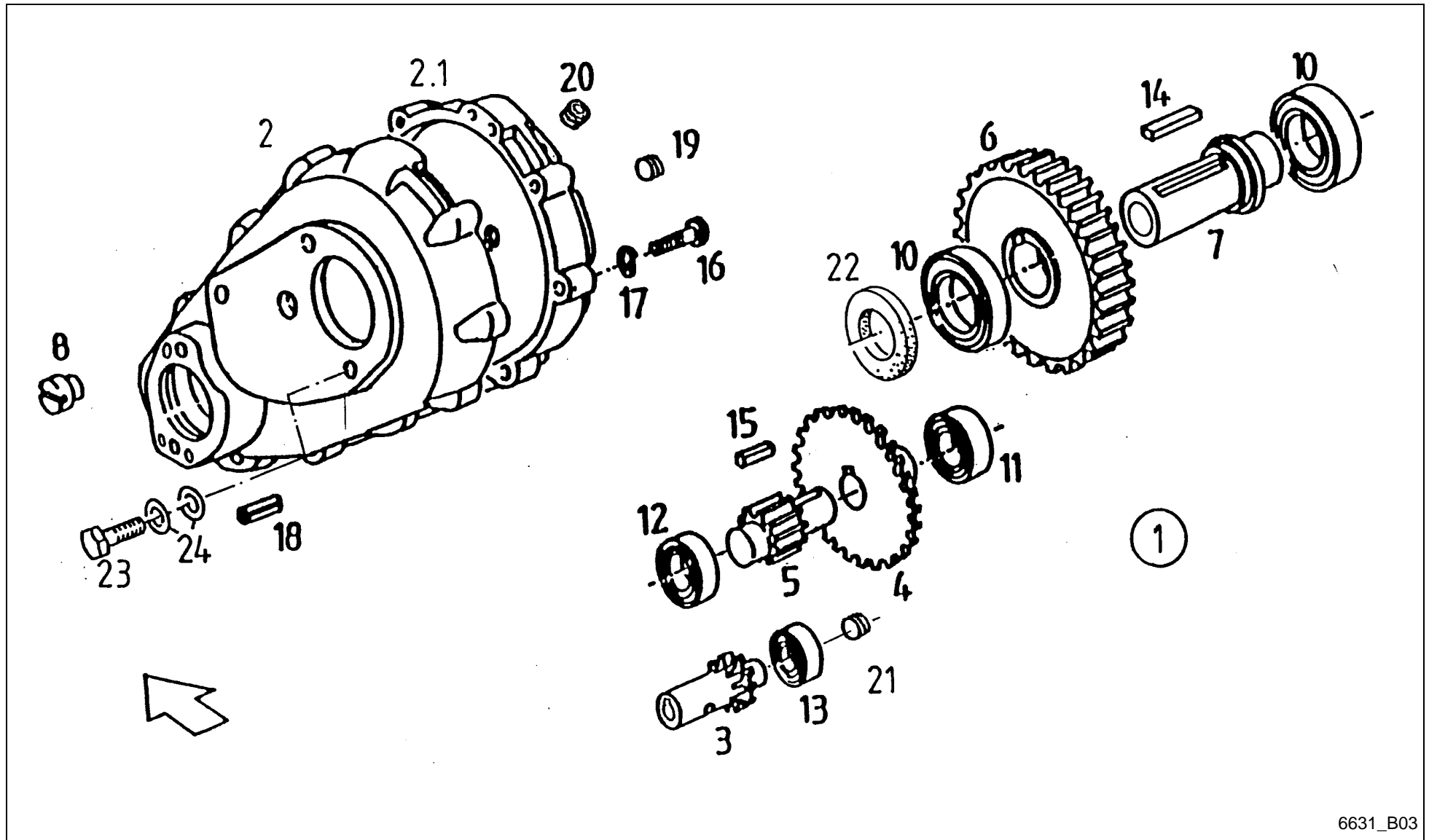

6631_B03

FeedMaster 3600T / SPUR GEAR BOOR



PosNo.	Part No.	Qty.	Description	Remark
1	VF16613261	1	SPUR-GEARING	
2	VF16611297	1	HALF-HOUSING	
2.1	VF16513607	1	HALF-HOUSING	
3	VF16611266	1	PINION SHAFT	
4	VF16611267	1	SPUR GEAR	
5	VF16513621	1	PINION SHAFT	
6	VF16513622	1	SPUR GEAR	
7	VF16611299	1	QUILL SHAFT	
8	VF16513624	1	PIN/SPIGOT	
10	VF01397576	2	BALL BEARING	
11	VF01108981	1	GR. BALL BEARING	
12	VF01109057	1	GR. BALL BEARING	
13	VF01109044	1	GR. BALL BEARING	
14	VF01397575	1	KEY	
15	VF06272542	1	KEY	
16	VF01126929	10	SCREW M10X 50D912 88A3C	
17	VF01102800	10	SPRING WASHER	
18	VF01397859	2	DOWEL PIN	
19	VF16611268	1	SCREW PLUG	
20	VF01110415	1	SCREW PLUG	
21	VF01124441	1	SCREW PLUG	
22	VF16611298	1	SEAL RING	
23	VF01177887	3	SCR.M16X40D933 8.8 GALV.DIN267-27MKL	
24	VF06214217	6	WASHER 17X28X3DIN1441 GALV.	

FeedMaster 3600T / UNIVERSAL-JOINT SHAFT

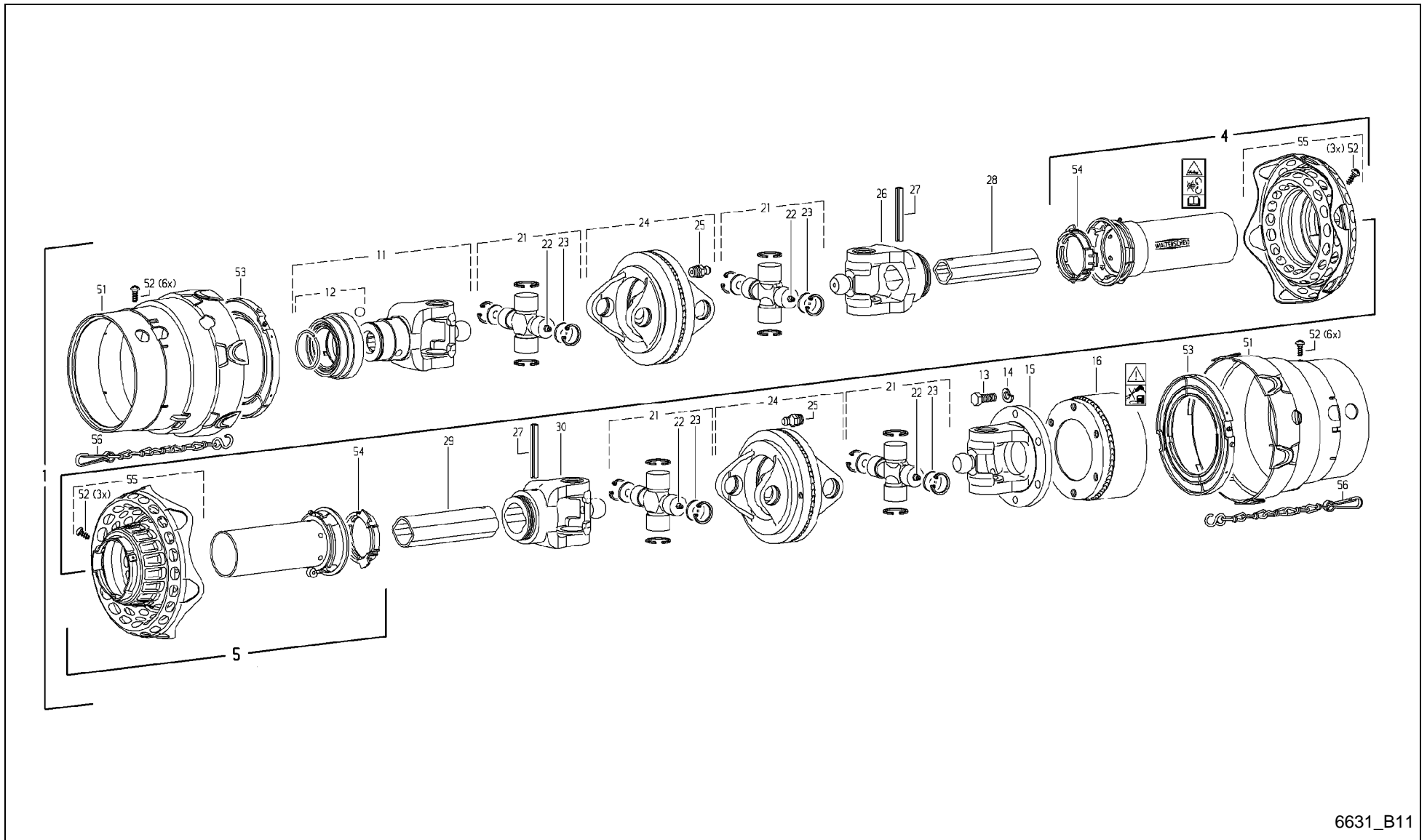

6631_B11

FeedMaster 3600T / UNIVERSAL-JOINT SHAFT



PosNo.	Part No.	Qty.	Description	Remark
1	VF16518245	1	UNIV PROP SHAFT	
4	VF16625120	1	PROTECTION HALF	
5	VF16625114	1	PROTECTION HALF	
11	VF16611252	1	QS-FORK KPL.	
12	VF06586171	1	FASTENER/LOCK	
13	KG00476561	6	HEX. SCREW M12X30 8.8	
14	A100000300	6	SPRING WASHER DIN127-A12	
15	VF16513601	1	FLANGED FORK	
16	A143502000	1	CLUTCH 1500NM	
21	WA135075	4	CROSS AND BEARING KIT 2480	
22	WA153207	4	GREASE NIPPLE	
23	VG35.06.70	8	DISC	
24	VF06586755	2	DOUBLE YOKE	
25	VG63.12.01	2	GREASE NIPPLE AM8X1-DIN71412	
26	VF06582340	1	FORK	
27	KG01194500	2	TENSION PIN 10X80	
28	WA135895	1	PROFILE TUBE	
29	WA135897	1	PROFILE TUBE	
30	VF16513605	1	FORK	
51	VG85.01.02	2	GUARD	
52	KG00742063	18	TAPPING SCREW 3.5X9.5 4.8	
53	VF16513616	2	SLIDING RING	
54	VF06581954	2	BEARING RING	
55	VF16625105	2	GUARD	
56	VF16513618	1	CHAIN 600MM	

FeedMaster 3600T / UNIVERSAL-JOINT SHAFT

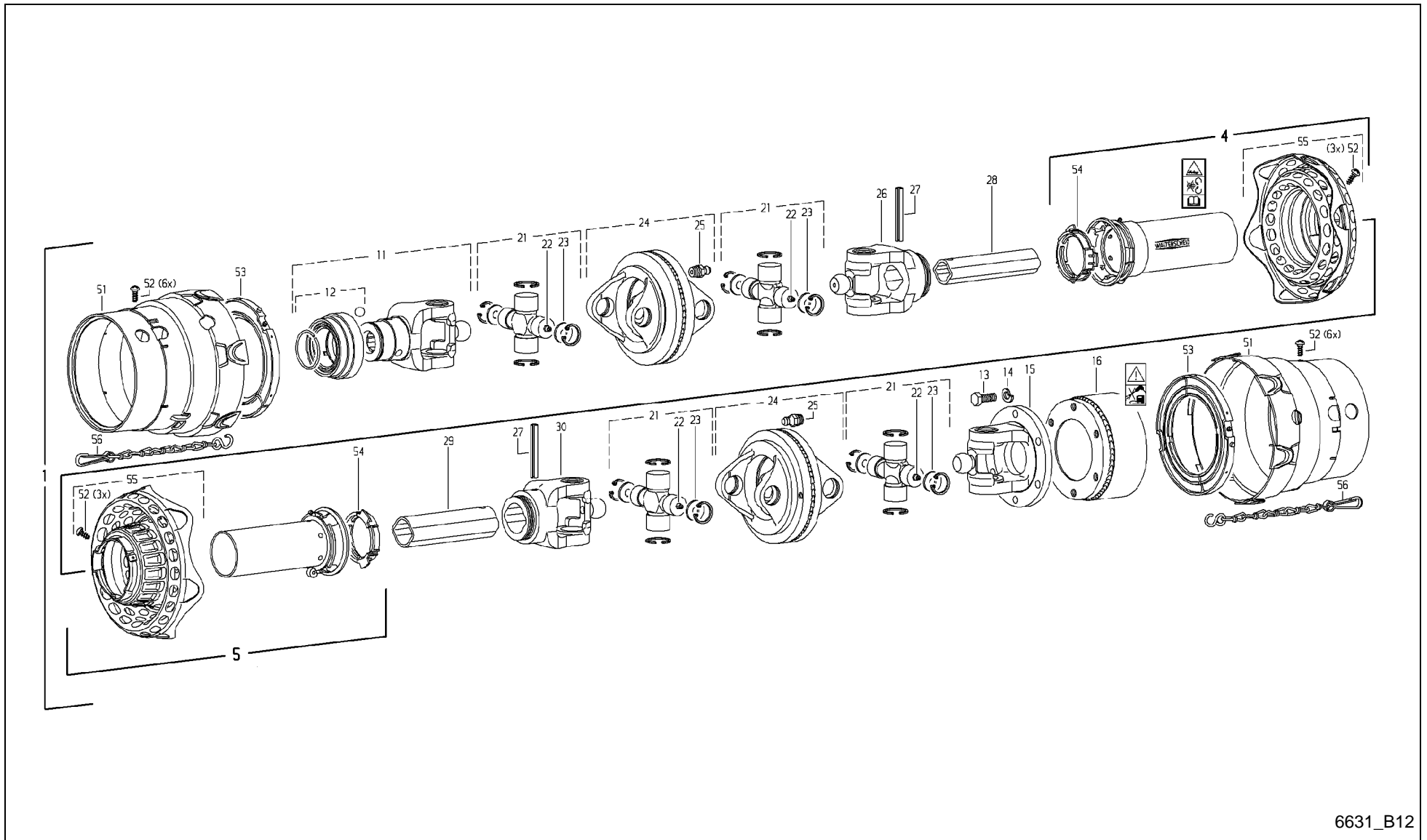

6631_B12

FeedMaster 3600T / UNIVERSAL-JOINT SHAFT



PosNo.	Part No.	Qty.	Description	Remark
1	VF16630383	1	SHAFT	
4	WA116565	1	OUTER GUARD HALF	
5	WA116566	1	INNER GUARD HALF BLACK	
11	VF16611252	1	QS-FORK KPL.	
12	VF06586171	1	FASTENER/LOCK	
13	KG00476561	6	HEX. SCREW M12X30 8.8	
14	A100000300	6	SPRING WASHER DIN127-A12	
15	VF16513601	1	FLANGED FORK	
16	A143501900	1	CAM CLUTCH	
21	WA135075	4	CROSS AND BEARING KIT 2480	
22	WA153207	4	GREASE NIPPLE	
23	VG35.06.70	8	DISC	
24	VF06586755	2	DOUBLE YOKE	
25	VG63.12.01	2	GREASE NIPPLE AM8X1-DIN71412	
26	VF06582340	1	FORK	
27	KG01194500	2	TENSION PIN 10X80	
28	WA135895	1	PROFILE TUBE	
29	WA135897	1	PROFILE TUBE	
30	VF16513605	1	FORK	
51	WA129948	2	GUARD CONE SDF25-2480 BLACK	
52	KG00742063	18	TAPPING SCREW 3.5X9.5 4.8	
53	VF16513616	2	SLIDING RING	
54	VF06581954	2	BEARING RING	
55	VF16625105	2	GUARD	
56	VF16513618	1	CHAIN 600MM	

FeedMaster 3600T / TANDEM-BRAKE AXLE (-A 2011)

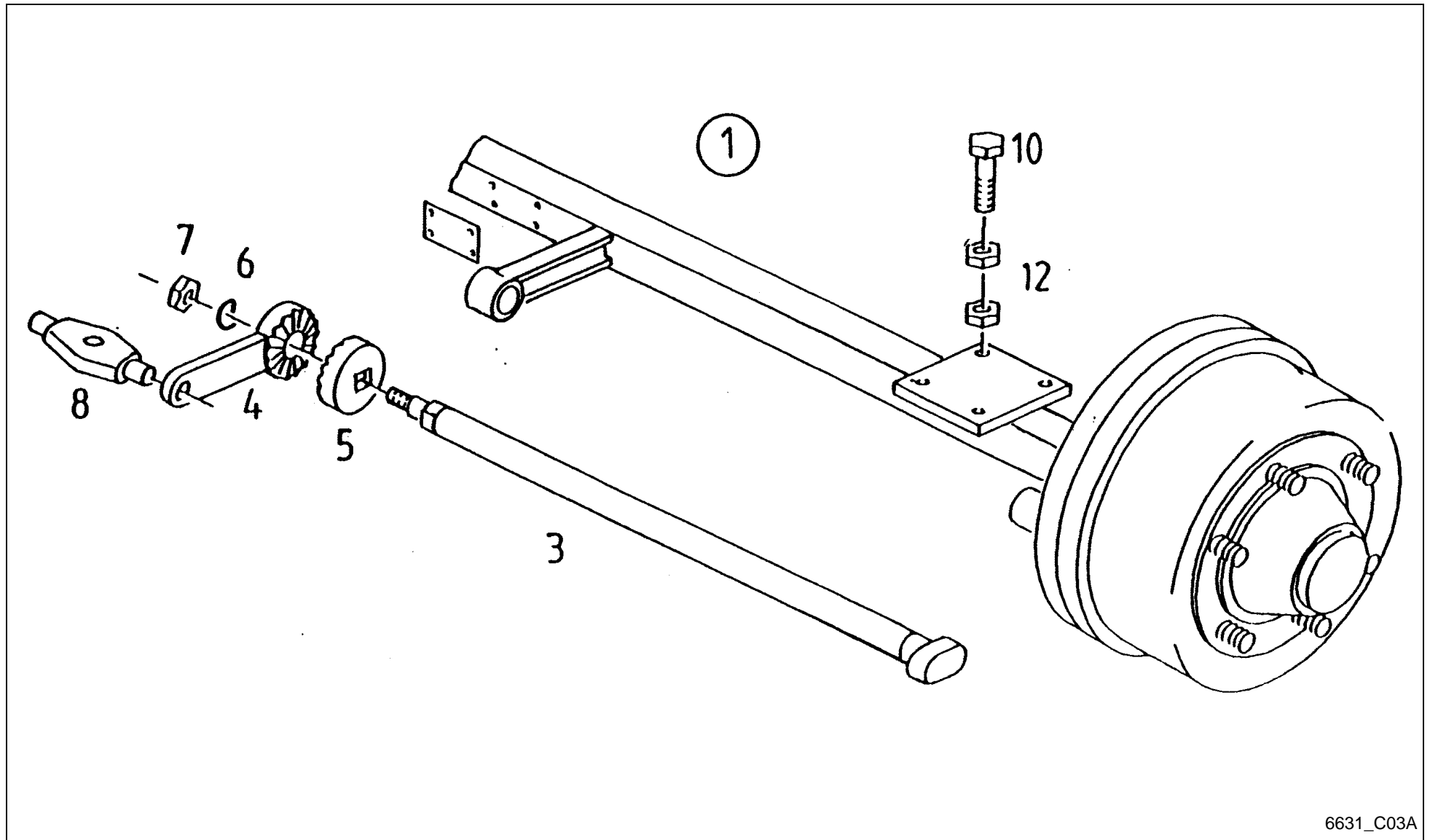

6631_C03A

FeedMaster 3600T / TANDEM-BRAKE AXLE (-A 2011)



PosNo.	Part No.	Qty.	Description	Remark
1	VF16630080	1	BRAKING SPINDLE	=> C04A/C09
3	VF16617334	2	BRAKE SHAFT	
4	VF16617333	2	BRAKE LEVER	
5	VF16617335	2	TOOTHED RING	
6	VF16616084	2	SPRING WASHER	
7	VF01133798	2	HEX. NUT	
8	VF16602179	1	COMPENSATOR	
10	VF06273759	8	HEX. HEAD SCREW	
12	VF01112886	16	HEX. NUT	

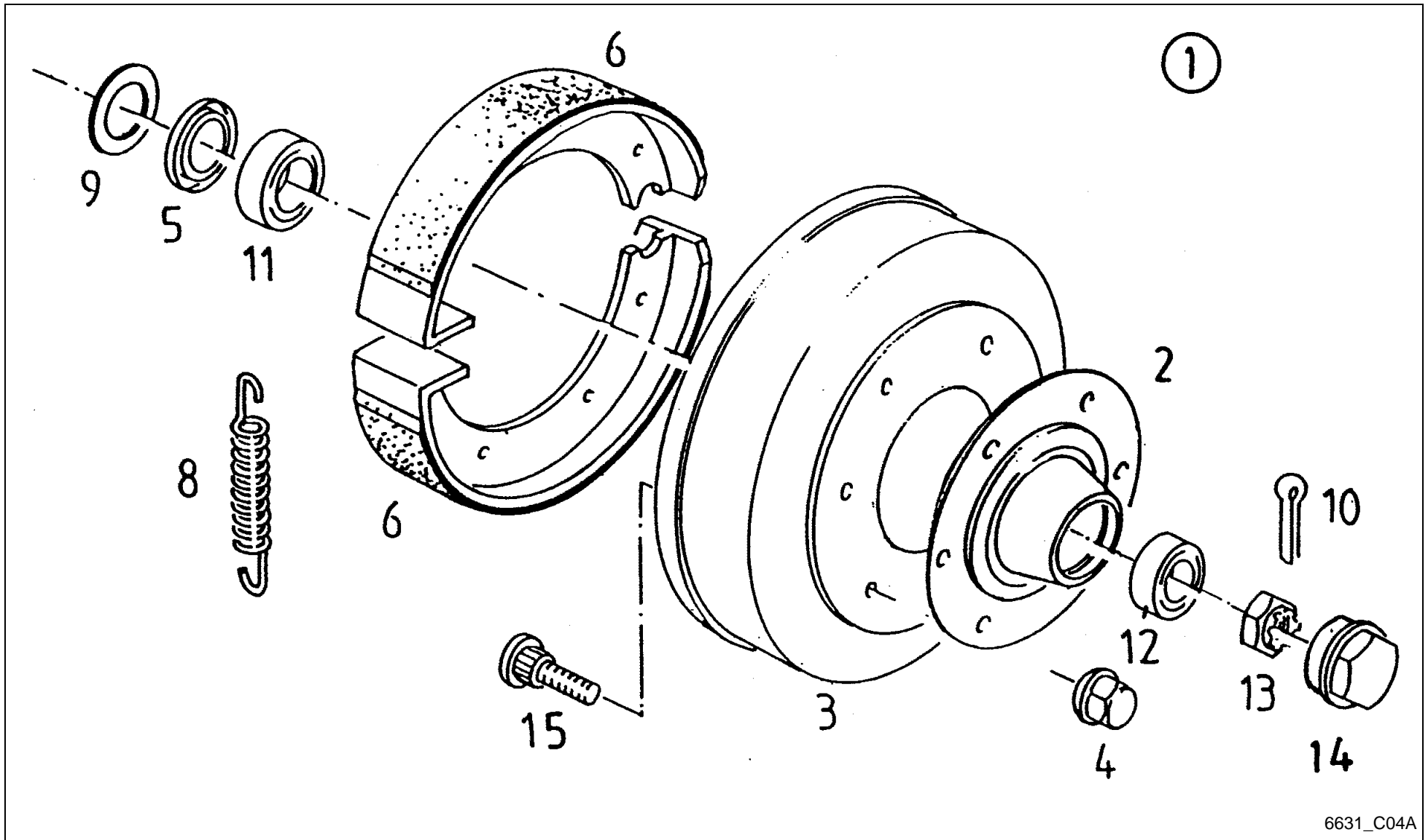

6631_C04A

FeedMaster 3600T / BRAKE (-A 2011)



PosNo.	Part No.	Qty.	Description	Remark
1	VF16630080	1	BRAKING SPINDLE	=> C03A/C09
2	VF16617329	2	WHEEL HUB	
3	VF16617330	2	BRAKE DRUM	
4	VF16515017	12	WHEEL NUT	
5	VF16612407	2	SEALING RING	
6	VF16617331	4	BRAKE SHOE	
8	VF16617332	4	TENSION SPRING	
9	VF16612408	2	RING	
10	VF01140002	2	SPLIT PIN	
11	VF01101596	2	TAP ROLLER BEARING AXLE	
12	VF01110001	2	TAPER R. BEARING	
13	VF16614447	2	CASTELLATED NUT	
14	VF16616040	2	WHEEL CAP	
15	VF16612402	12	WHEEL STUD	

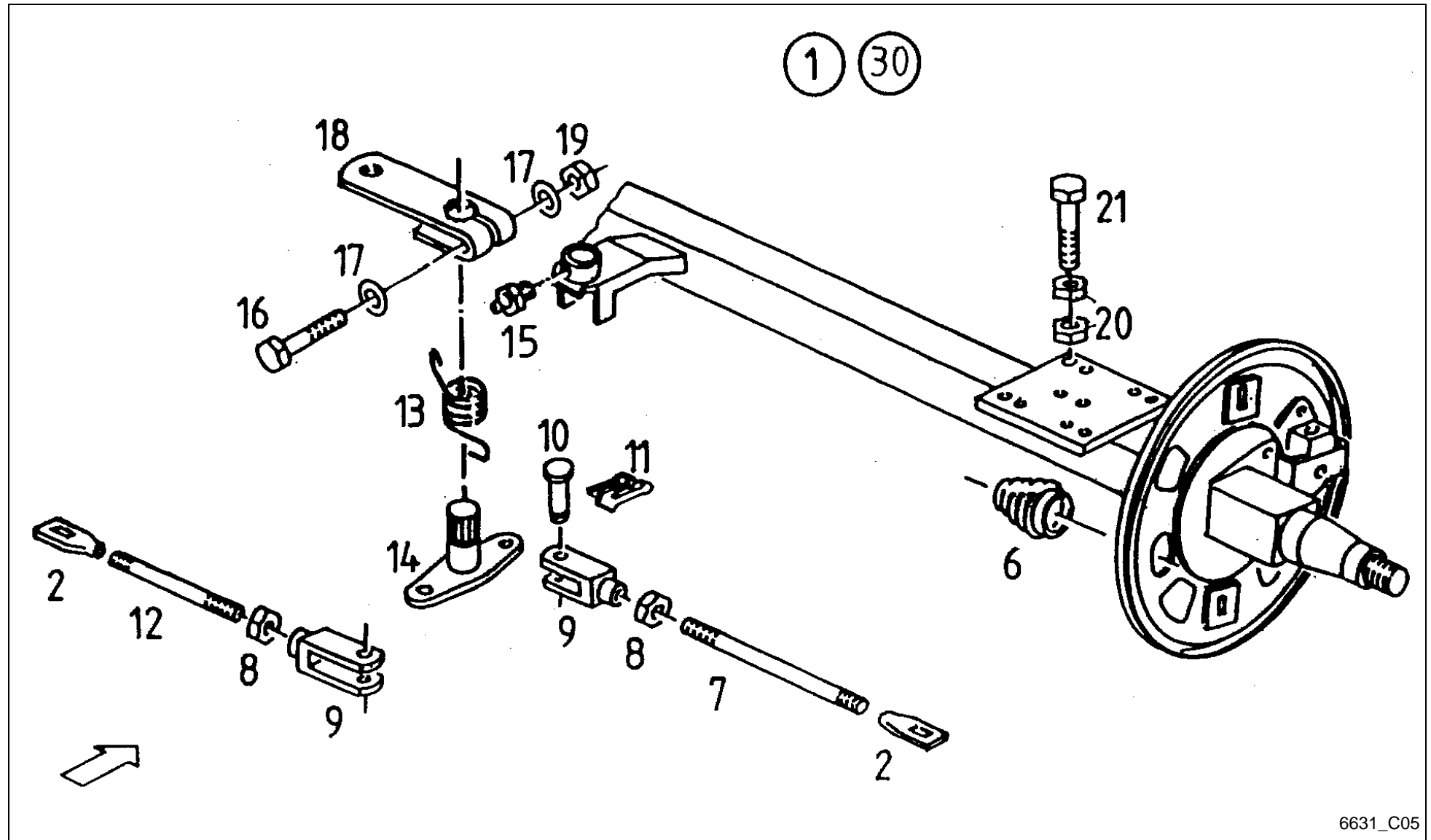

6631_C05

FeedMaster 3600T / BRAKE AXLE TANDEM AUTOREVERSE TANDEM.PRESS AIR ()



PosNo.	Part No.	Qty.	Description	Remark
1	VF16516646	1	BRAKE AXLE	=> C09 -700 Rückm.
1	VF16630397	1	BRAKE AXLE	+701 Rückmatic
2	VF16612413	2	HINGED PIECE	
6	VF16503949	2	BELLOWS	
7	VF16612427	1	BRAKE BAR	
8	VF01112858	2	NUT	
9	VF16612424	2	CLEVIS	
10	VF16612425	2	PIN/BOLT/STUD	
11	VF16612426	2	LOCK/COTTER	
12	VF16612423	1	BRAKE BAR	
13	VF16612428	1	TORSION SPRING	
14	VF16612429	1	LEVER/ARM	
15	VF01120692	1	GREASE NIPPLE H1 AM 6X1 DIN 71412	
16	VF01111325	1	HEX.HEAD SCREW	
17	VF16612430	2	WASHER/DISC/PLATE	
18	VF16612431	1	YOKE/RETAINER	X1,X30 -700 Rückm.
18	VF16630394	1	YOKE/RETAINER	X1.1 +701 Rückm.
19	VF01102659	1	HEX. NUT	
20	VF01112886	16	HEX. NUT	
21	VF06273759	8	HEX. HEAD SCREW	
30	VF16630078	1	BRAKE AXLE	+701 Druckluft

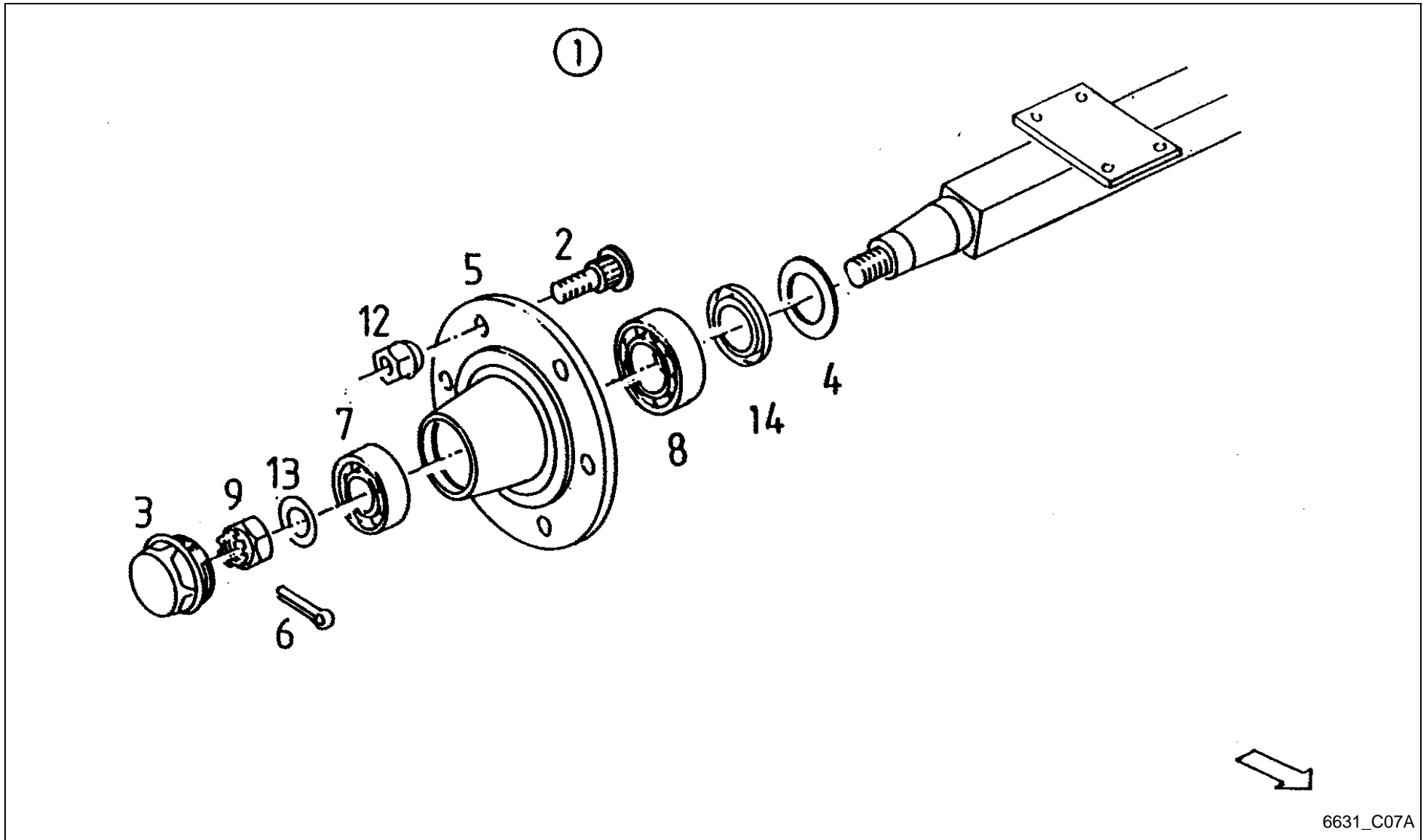

6631_C07A

FeedMaster 3600T / TANDEM-WHEEL AXLE HYDRAULIC +501



PosNo.	Part No.	Qty.	Description	Remark
1	VF16630075	1	WHEEL AXLE	=> C09
2	VF16614444	12	BOLT, WHEEL	
3	VF16616040	2	WHEEL CAP	
4	VF16612408	2	RING	
5	VF16617329	2	WHEEL HUB	
6	VF01140002	2	SPLIT PIN	
7	VF01110001	2	TAPER R. BEARING	
8	VF01101596	2	TAP ROLLER BEARING AXLE	
9	VF16614447	2	CASTELLATED NUT	
12	VF16515017	12	WHEEL NUT	
13	VF06557524	2	WASHER/DISC/PLATE	
14	VF16612407	2	SEALING RING	

FeedMaster 3600T / ASSEMBLY PENDULAR

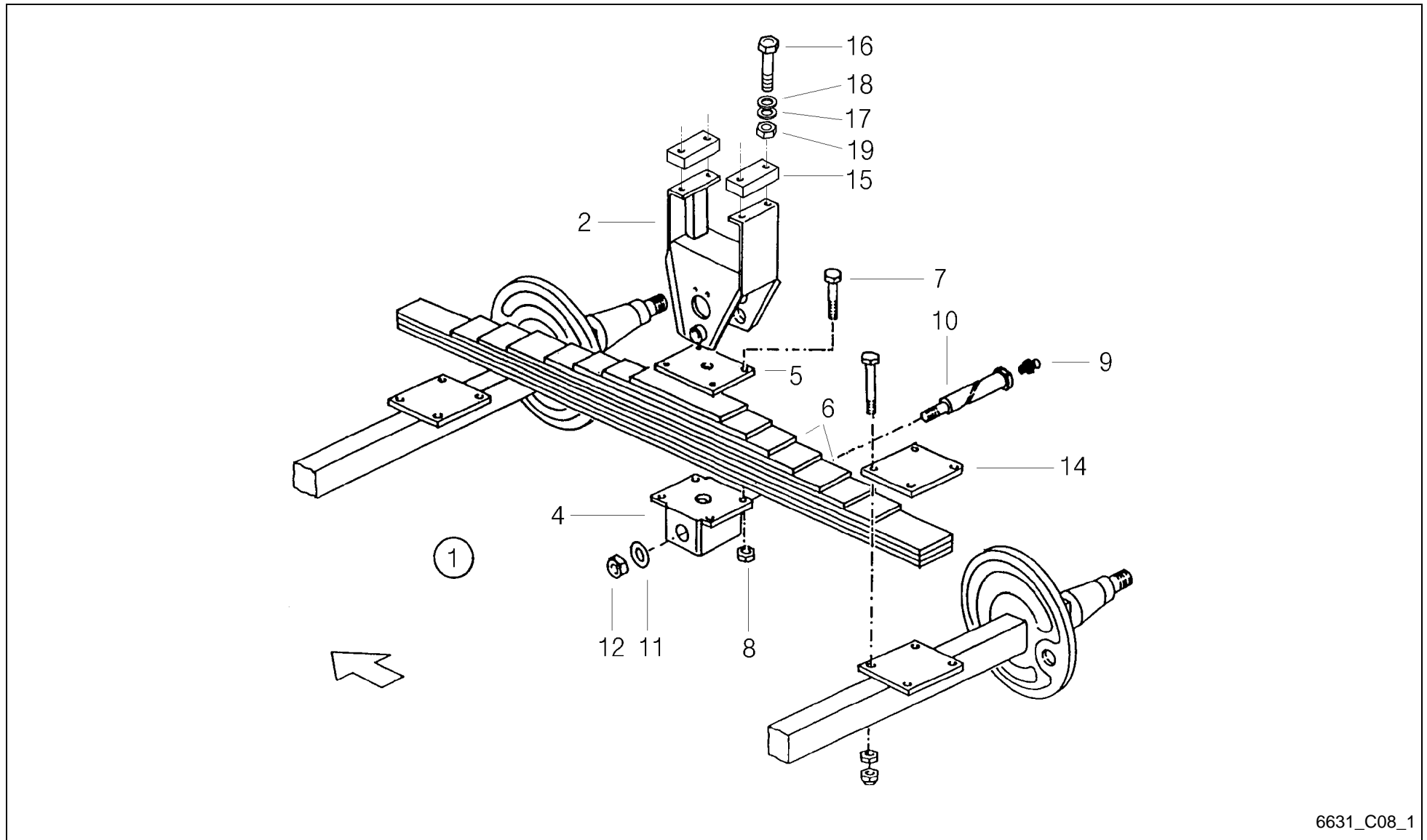

6631_C08_1

FeedMaster 3600T / ASSEMBLY PENDULAR



PosNo.	Part No.	Qty.	Description	Remark
1	VF16630104	1	ASSEMBLY PENDULAR	S C09/1
2	VF16630100	2	AXLE BRACKET	
4	VF16518869	2	SPRING SEAT	
5	VF16513257	2	PLATE	
6	VF16630232	2	LEAF SPRING	bei Ersatz paarweise wechseln
7	VF06209168	8	BOLT	
8	VF06209774	8	LOCK NUT	
9	VF01120694	2	GREASE NIPPLE	
10	VF16518871	2	ANCHOR PIN	
11	VF16518150	2	WASHER/DISC/PLATE	
12	VF01397661	2	HEX.NUT	
14	VF16513259	4	PLATE	
15	A143039786	4	SHIM	bei Bereifung 500/50/17
16	VF06273759	8	HEX. HEAD SCREW	bei Bereifung 500/50/17
17	VF01142556	8	SPACING RING	bei Bereifung 500/50/17
18	VF06214220	8	WASHER 17X34X3 GALV.	bei Bereifung 500/50/17
19	VF01127856	8	LOCK NUT	bei Bereifung 500/50/17

FeedMaster 3600T / SPRING BORN TENDEM AXLE (8TO.)

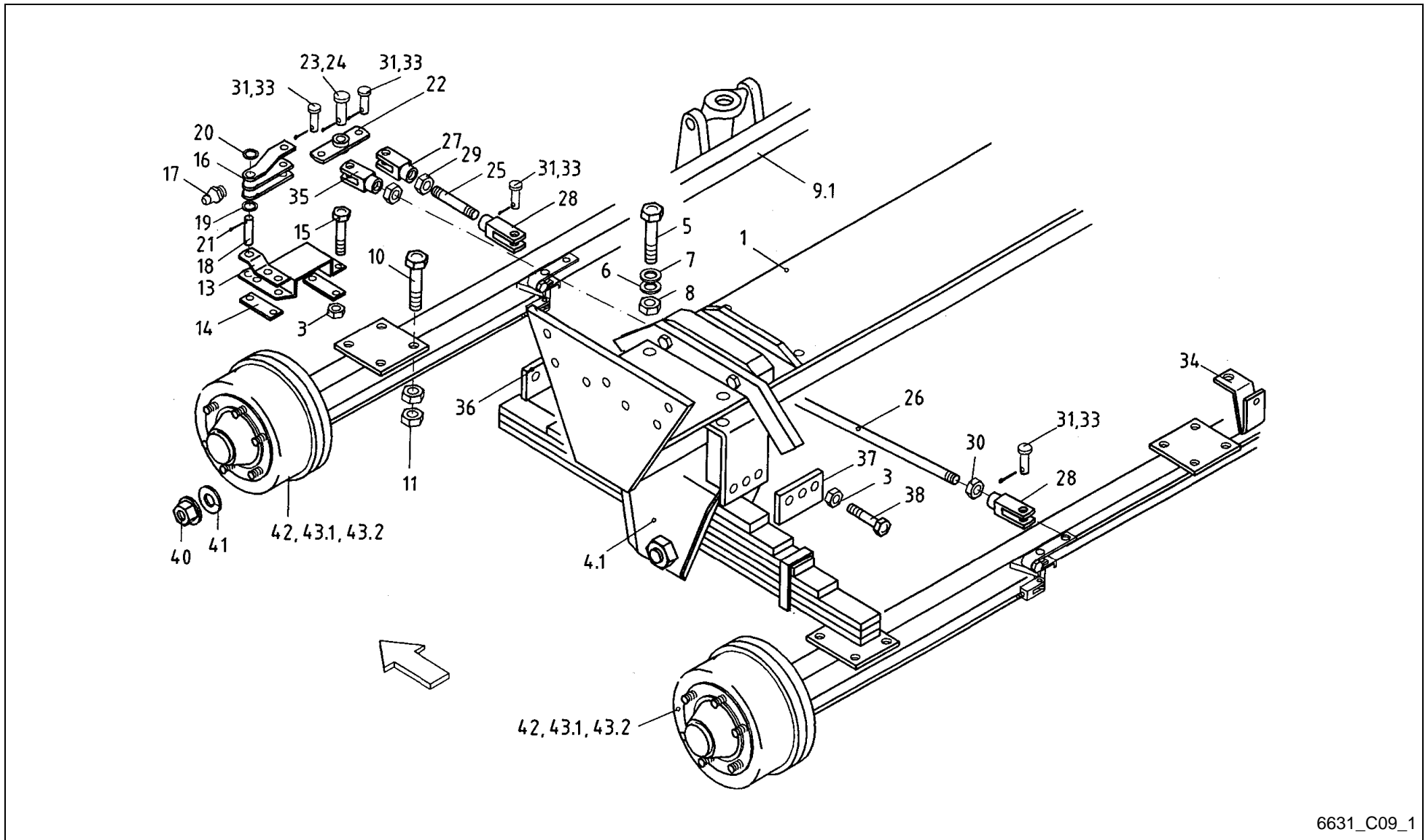

6631_C09_1

FeedMaster 3600T / SPRING BORN TENDEM AXLE (8TO.)



PosNo.	Part No.	Qty.	Description	Remark
1	VF16611492	1	AXLE CARRIER	
3	VF06209778	24	LOCK NUT	
4.1	VF16630104	1	ASSEMBLY PENDULAR	S C08/1
5	VF01111861	8	HEX.BOLT	
6	VF01142556	8	SPACING RING	
7	VF06214220	8	WASHER 17X34X3 GALV.	
8	VF01127856	8	LOCK NUT	
9.1	VF16630397	2	BRAKE AXLE	S C27 Rückmatik
10	VF06273759	16	HEX. HEAD SCREW	
11	VF01112886	32	HEX. NUT	
13	VF16516363	1	SUPPORT PLATE	
14	VF16516380	2	CONNECTING PLATE	
15	VF01111562	4	HEX.HEAD SCREW	
16	VF16516368	1	LEVER/ARM	
17	VF01120692	1	GREASE NIPPLE H1 AM 6X1 DIN 71412	
18	VF06209952	1	PIN/BOLT/STUD	
19	VF06214229	2	WASHER 21X32X2 GALV.	
20	VF06214226	2	WASHER	
21	VF01122072	2	SPLIT PIN	
22	VF16516374	1	BRAKE COMP.DEV.	
23	VF01139468	1	PIN	
24	VF01106451	1	SPLIT PIN	
25	VF16516500	1	PULLROD	
26	A143031663	1	PULLROD L=1200	
27	VF01123290	1	CLEVIS	
28	VF01120915	3	FORK HEAD	
29	VF01112850	1	HEX. HEAD SCREW	
30	VF01102659	3	HEX. NUT	
31	VF06210009	4	PIN	
33	VF01132625	4	SPLIT PIN	
34	VF16516512	2	RETAINER	
36	VF16516398	2	STOP	
37	VF16511646	2	STOP	
38	VF01111475	12	HEX. HEAD SCREW	
40	VF01121797	24	FLAT-COLLAR NUT	
41	VF01121808	24	SPRING LOCKWASHER	
42	VF16630078	2	BRAKE AXLE	S C28 Druckluft
43.1	VF16630080	2	BRAKING SPINDLE	S C25 Hydraulik
43.2	VF16631886	2	ACHSE BREIT	Bauvariante S C20-x

FeedMaster 3600T / ASSORTMENT OF WHEEL

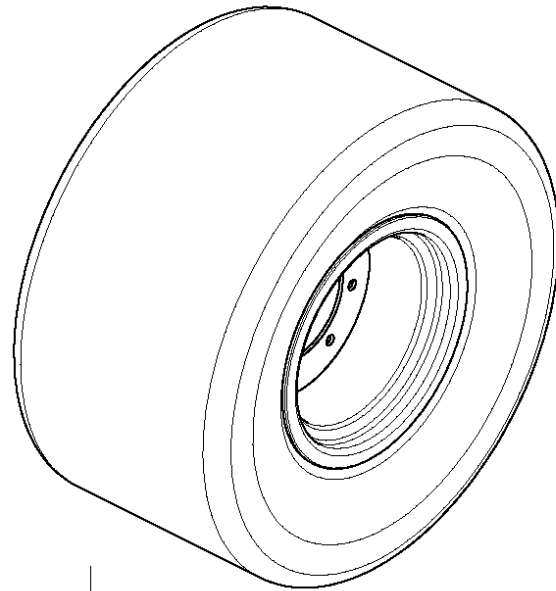

11, 12, 13, 14, 15

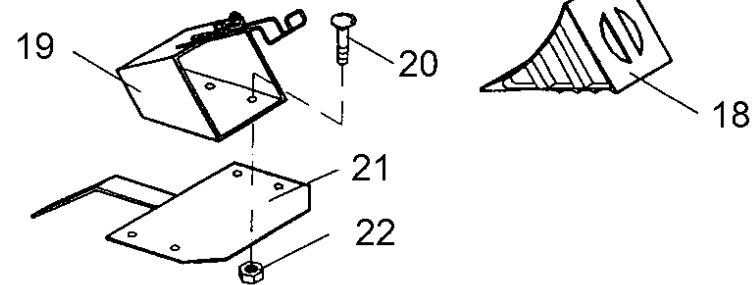

6631_C10

FeedMaster 3600T / ASSORTMENT OF WHEEL



PosNo.	Part No.	Qty.	Description	Remark
11	VF16512621	4	WHEEL	Tandem
11.1	VF16512621	2	WHEEL	Single
12	VF01397605	4	GEAR/WHEEL	Tandem
12.1	VF01397605	2	GEAR/WHEEL	Single
13	A143014600	4	WHEEL	Tandem -A 2016
13.1	A143014600	2	WHEEL	Single -A 2016
14	A143014300	2	WHEEL	Single
15	A143037800	4	WHEEL	Tandem +A 2017
15.1	A143037800	2	WHEEL	Single +A 2017
18	VF16630072	2	STOP-BLOCK	
19	VF16630070	2	SUPPORT	
20	VF01137624	8	SCREW	
21	VF16630069	2	SUPPORT	
22	VF01104944	8	NY LOCK NUT 8A3CD985	

FeedMaster 3600T / BRAKE CABLE TAN. AXLE AUTOREVERSE

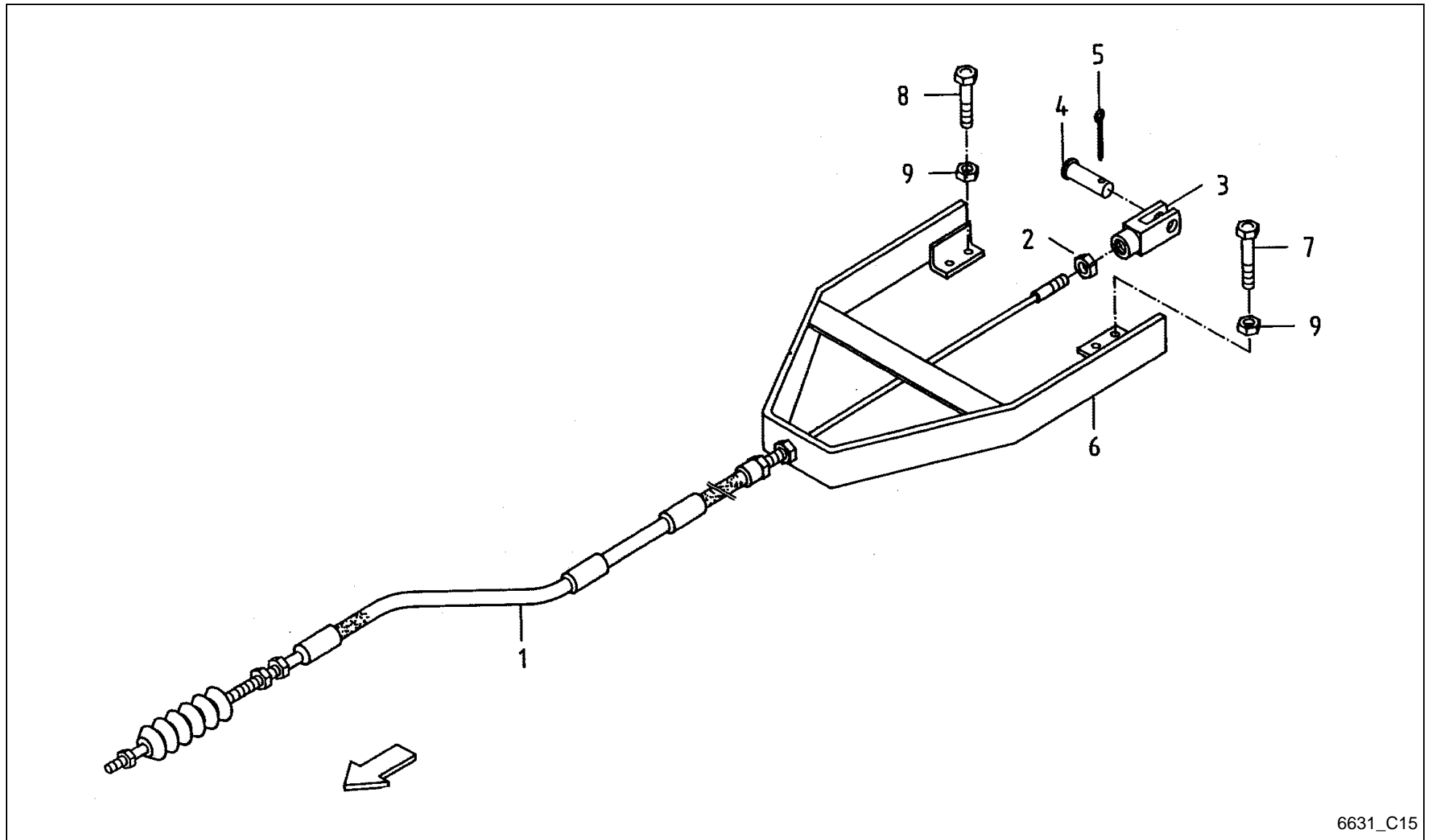

6631_C15

FeedMaster 3600T / BRAKE CABLE TAN. AXLE AUTOREVERSE



PosNo.	Part No.	Qty.	Description	Remark
1	VF16611497	1	BRAKE CABLE	
2	VF01112858	1	NUT	
3	VF01120923	1	FORK	
4	VF06210014	1	PIN	
5	VF01106447	1	SPLIT PIN	
6	VF16613248	1	RETAINER	
7	VF01112538	2	HEX.HEAD SCREW	
8	VF01112529	2	HEX.HEAD SCREW	
9	VF06209769	4	LOCK NUT	

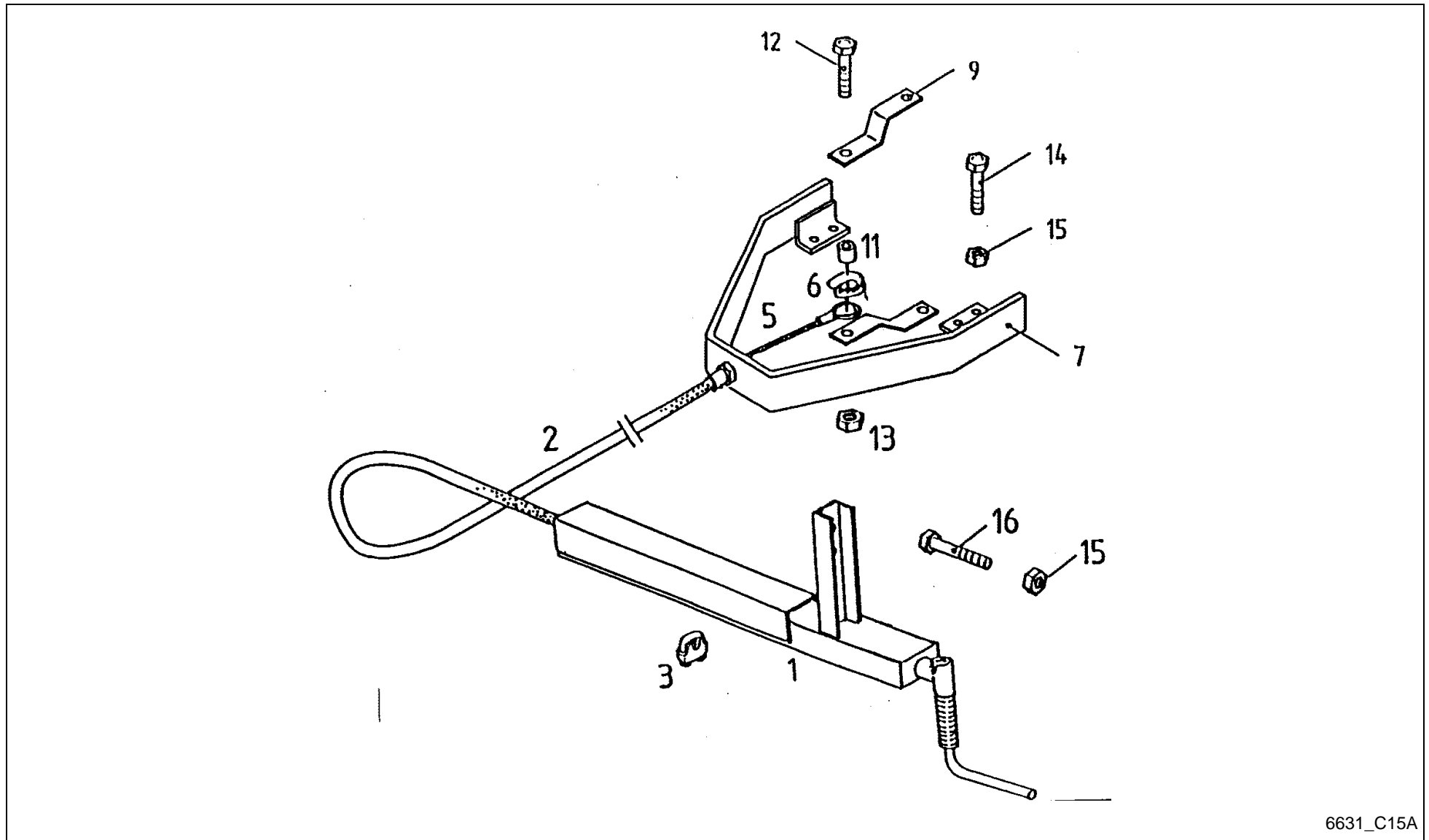

6631_C15A

FeedMaster 3600T / HANDBRAKE TAND AXLE SPR BORN PRESS AIR BRAKE



PosNo.	Part No.	Qty.	Description	Remark
1	VF16516507	1	PARKING BRAKE	
2	VF06558917	1	CABLE HOSE	
3	VF01136686	2	CABEL CLAMP S 5 DIN1142- GALV.	
5	VF16513859	1	BRAKE CABLE	
6	VF01139169	1	THIMBLE B 5 DIN6899- GALV.	
7	VF16516382	1	YOKE/RETAINER	
9	VF16513860	2	LASCHE	
11	VF16513861	1	BUSH	
12	VF01112429	1	HEX. HEAD SCREW	
13	VF06209768	1	LOCK NUT	
14	VF01112538	4	HEX.HEAD SCREW	
15	VF06209769	6	LOCK NUT	
16	VF01112529	2	HEX.HEAD SCREW	

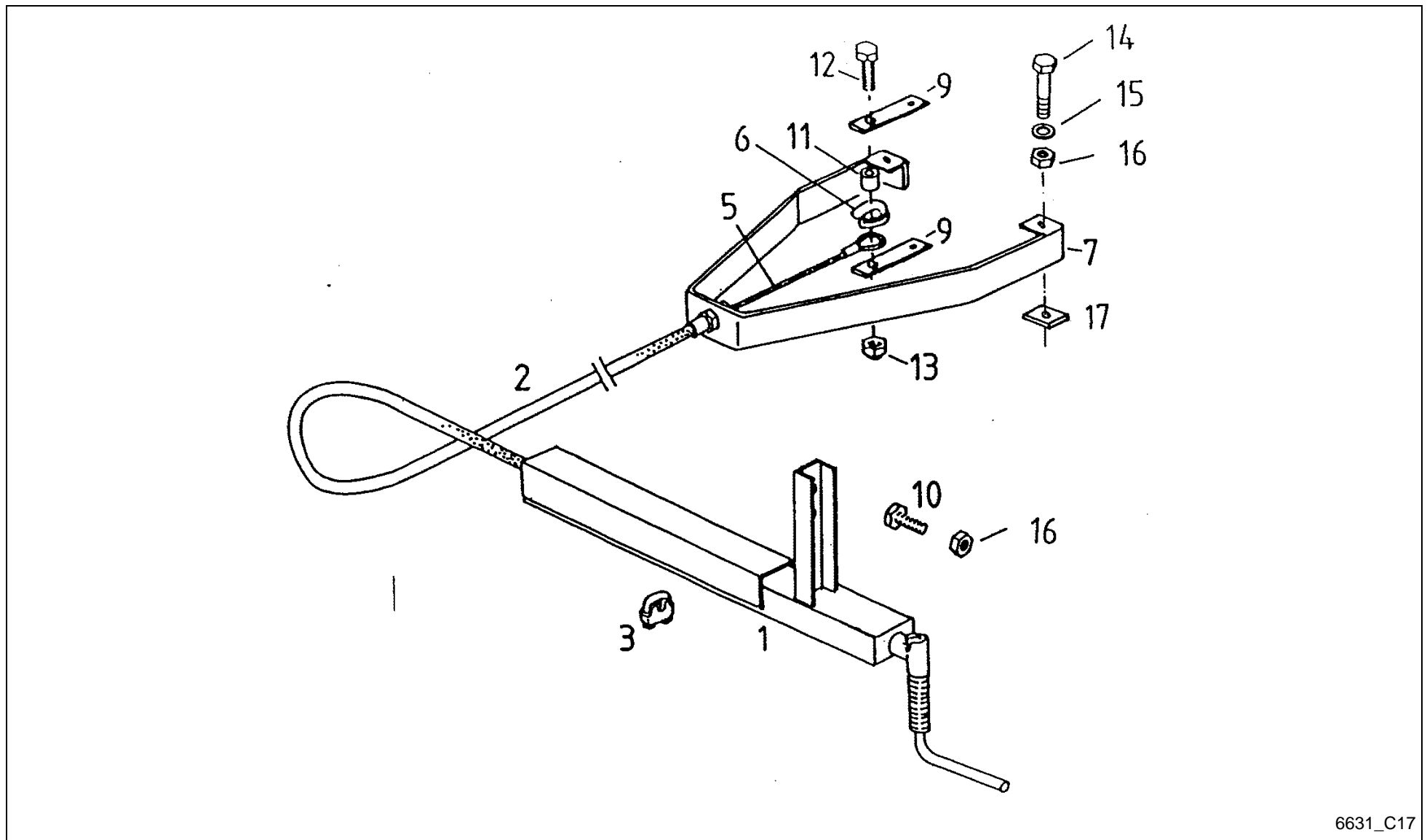

6631_C17

FeedMaster 3600T / HANDBRAKE TAND.AXLE 9TO.2 BRAKES HYDR.



PosNo.	Part No.	Qty.	Description	Remark
1	VF16516507	1	PARKING BRAKE	
2	VF06558917	1	CABLE HOSE	
3	VF01136686	2	CABEL CLAMP S 5 DIN1142- GALV.	
5	VF16513859	1	BRAKE CABLE	
6	VF01139169	1	THIMBLE B 5 DIN6899- GALV.	
7	VF16513686	1	YOKE/RETAINER	
9	VF16516440	2	CONNECTING PLATE	
10	VF01112529	2	HEX.HEAD SCREW	
11	VF16516441	1	SPACER TUBE	
12	VF01111308	1	HEX. HEAD SCREW	
13	VF06209768	1	LOCK NUT	
14	KG00357500	2	HEX. BOLT M12X50 8.8	
15	VF06214206	2	WASHER 13X30X4 RM=580-680 MPA A2C	
16	VF06209769	2	LOCK NUT	
17	VF16516442	2	SHIM	

FeedMaster 3600T / BRAKE HYDRAULIC (FANCE)

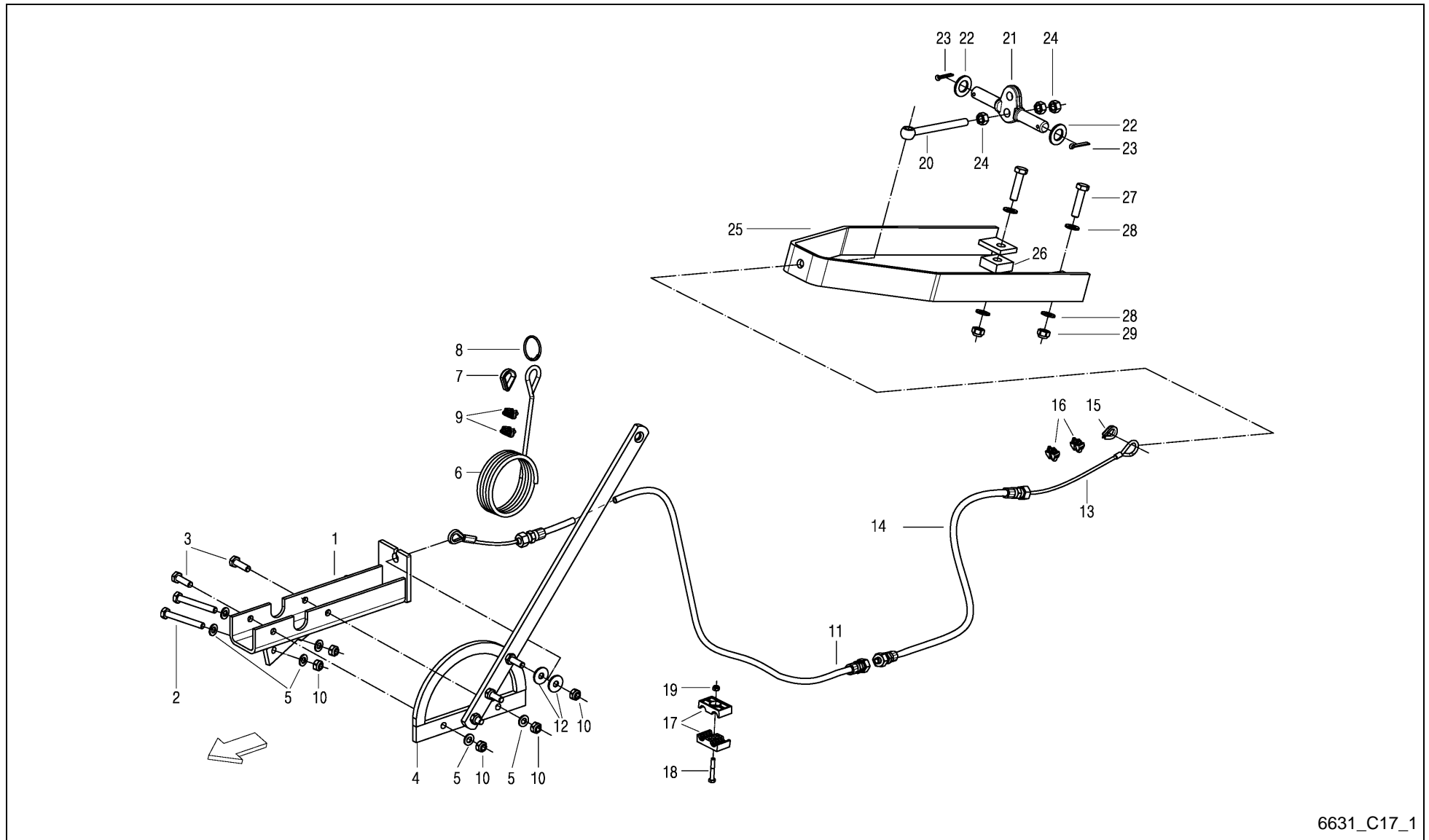

6631_C17_1

FeedMaster 3600T / BRAKE HYDRAULIC (FANCE)



PosNo.	Part No.	Qty.	Description	Remark
1	VF16635241	1	CONSOLE	
2	VF01111339	2	HEX. HEAD SCREW	
3	VF01112439	2	HEX. HEAD SCREW	
4	VF16631482	1	HAND BRAKE LEVER	
5	VF01107165	4	WASHER M10 11X20X2 A2C DIN126	
6	VF06587631	1	CABLE	
7	VF01137837	1	THIMBLE	
8	VNB3469202	1	SAFETY RING	
9	VF01136687	1	CLAMPING PIECE	
10	VF06209768	8	LOCK NUT	
11	VF06558733	1	CABLE HOSE	
12	VF06214197	2	WASHER 10,5X30X3 GALV.	
13	VF06558728	1	BRAKE CABLE	
14	VF16518193	1	CABLE HOSE	
15	VF01139169	2	THIMBLE B 5 DIN6899- GALV.	
16	VF01136686	2	CABEL CLAMP S 5 DIN1142- GALV.	
17	VF06578035	2	CLAMP	
18	VF01111071	1	HEX. HEAD SCREW	
19	VF01114357	1	LOCK NUT	
20	VF06207186	1	EYEBOLT	
21	VF03.110.02.140	1	BRAKE BALANCE	
22	VF06214226	2	WASHER	
23	VF01122072	2	SPLIT PIN	
24	VF01125801	3	HEX. NUT	
25	VF16635269	1	YOKE	
26	VF16516442	2	SHIM	
27	VF01111486	2	HEXAGON HEAD SCREW M12X50 DIN 931 8.8	
28	VF06214206	4	WASHER 13X30X4 RM=580-680 MPA A2C	
29	VF06209769	2	LOCK NUT	

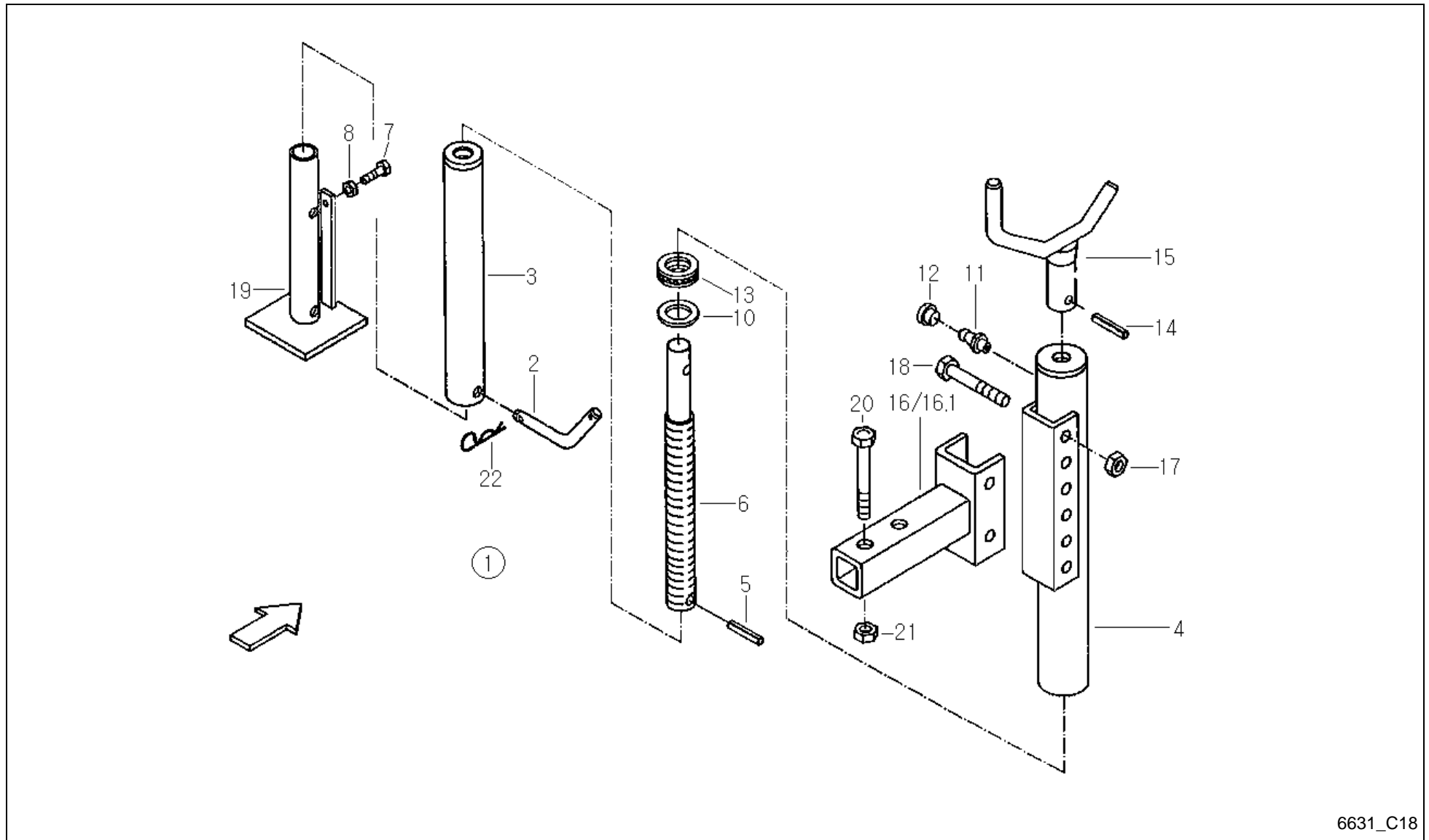

FeedMaster 3600T / PARKING STAND (-A 2016)



PosNo.	Part No.	Qty.	Description	Remark
1	VF16613267	1	PRASED PARTS	
2	VF16614473	1	BOLT	
3	VF16614474	1	INNER TUBE	
4	VF16614475	1	EXTERNAL TUBE	
5	KG01185862	2	TENSION PIN 4X16	
6	VF16614480	1	SPINDLE	
7	VF01112307	1	HEX. HEAD SCREW	
8	VF01112824	1	HEX. NUT	
10	VF01141047	1	WASHER 21,0X44,0X5,0	
11	VF01120693	1	GREASE FITTING H1 AM 8X1 DIN 71412	
12	VF16514101	1	PLUG	
13	VF01109886	1	GR. BALL BEARING	
14	VF01115457	1	DOWEL PIN	
15	VF16614479	1	CRANK HANDLE	
16	VF16614478	1	RETAINER	-A 2006
16.1	VF16631486	1	RETAINER	+A 2007
17	VF06209774	2	LOCK NUT	
18	VF01139339	2	HEX.BOLT	
19	VF16614472	1	SUPPORT	
20	VF16630548	1	HEXAGON HEAD SCREW M16X130 D931 10.9	
21	VF01127856	1	LOCK NUT	
22	VF06215671	1	PIN	

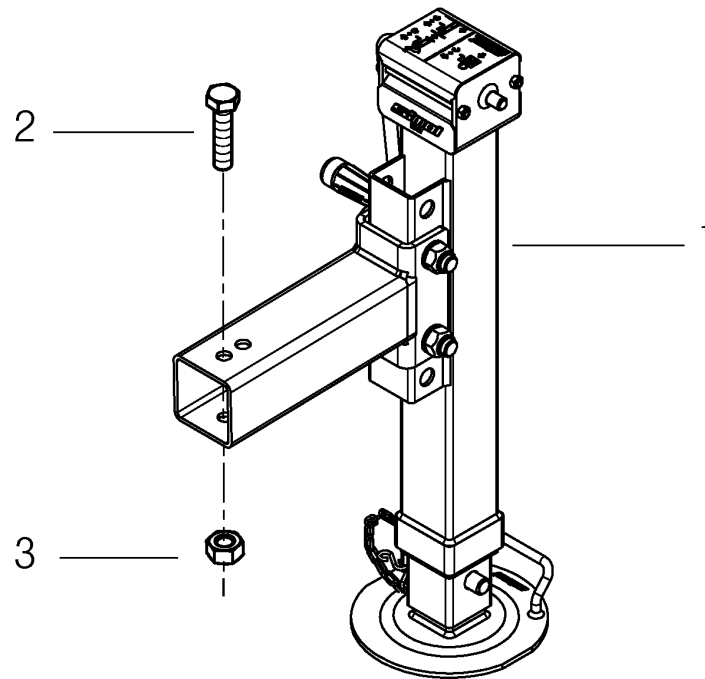

FeedMaster 3600T / PARKING STAND (+A 2017)



PosNo.	Part No.	Qty.	Description	Remark
1	A143039830	1	SUPPORT	
2	VF01111941	1	HEX.BOLT	
3	VF01127856	1	LOCK NUT	

FeedMaster 3600T / BRAKE AXLE TANDEM HYDRAULIC TRACK 2000 (constructive variant)

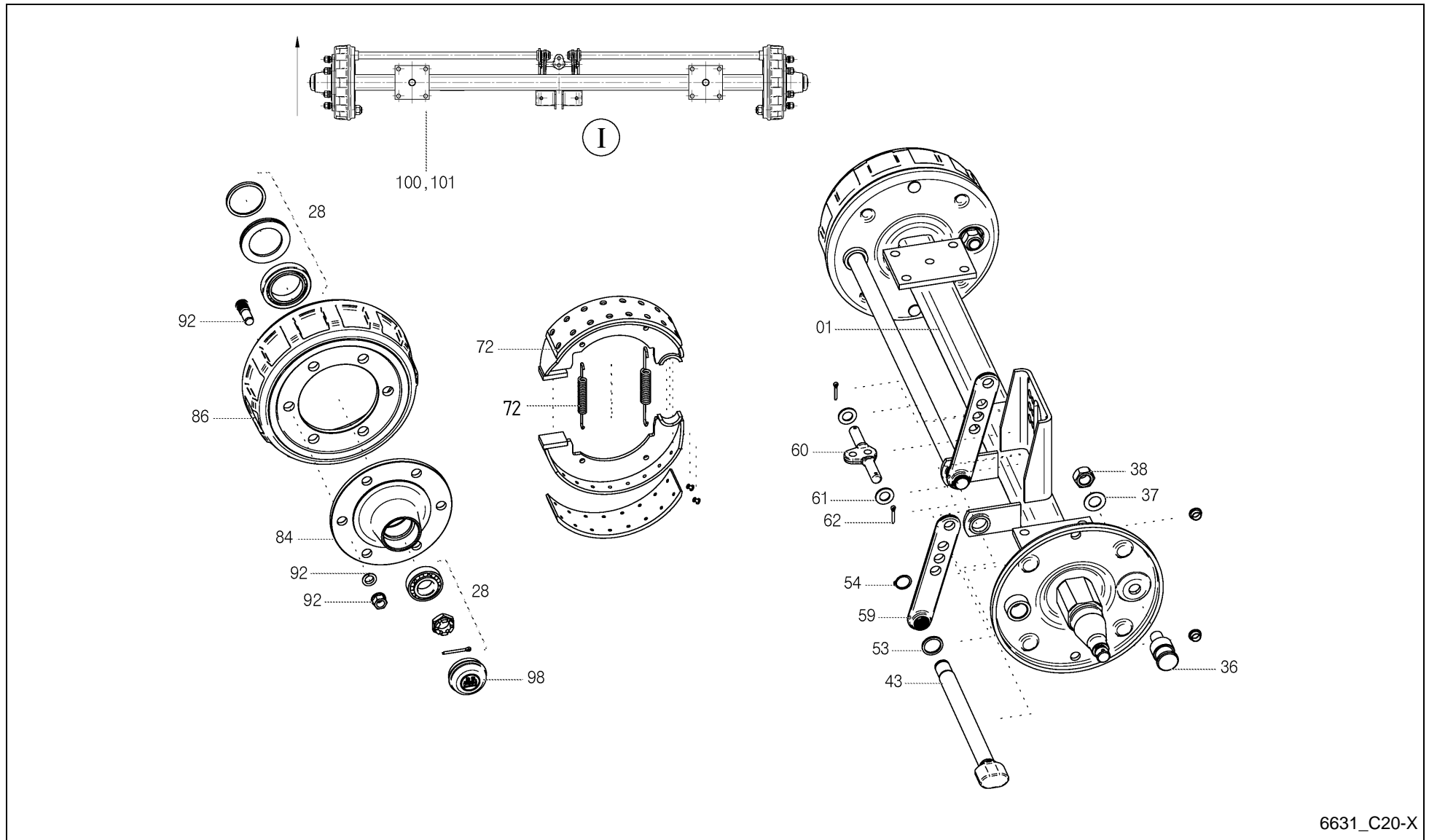

6631_C20-X

FeedMaster 3600T / BRAKE AXLE TANDEM HYDRAULIC TRACK 2000 (constructive variant)



PosNo.	Part No.	Qty.	Description	Remark
I	VF16631886	1	ACHSE BREIT	
1	A143507300	1	AXLE BODY, GROUP	
28	A143503000	1	STORAGE PARTS SETS	
36	VF16602599	2	THREADED PIN	
37	VF16602600	2	WASHER	
38	A143503100	2	LOCK NUT VM24X1,5 DIN980	
43	A143507400	2	BRAKE CAMSHAFT L=925 / A=838	
53	A143503300	2	RING 42/34X4	
54	VF16618627	2	CIRCLIP	
59	A143503400	2	BRAKE LEVER	
60	VF03.110.02.140	1	BRAKE BALANCE	
61	A143475200	2	WASHER 21 DIN125	
62	VF01122071	2	SPLIT PIN 5,0X28 DIN94 A3C	
72	A143503600	1	BRAKE SHOE SET, KIT	
84	VF16617329.86	2	WHEEL HUB	
86	VF16617330.86	2	BRAKE DRUM	
92	A143503700	12	WHEEL STUD SET M18X57	
98	VF16612405	2	WHEEL CAP	
100	VF06273759	8	HEX. HEAD SCREW	
101	VF01112886	16	HEX. NUT	

FeedMaster 3600T / BRAKE AXLE TANDEM HYDRAULIC ()

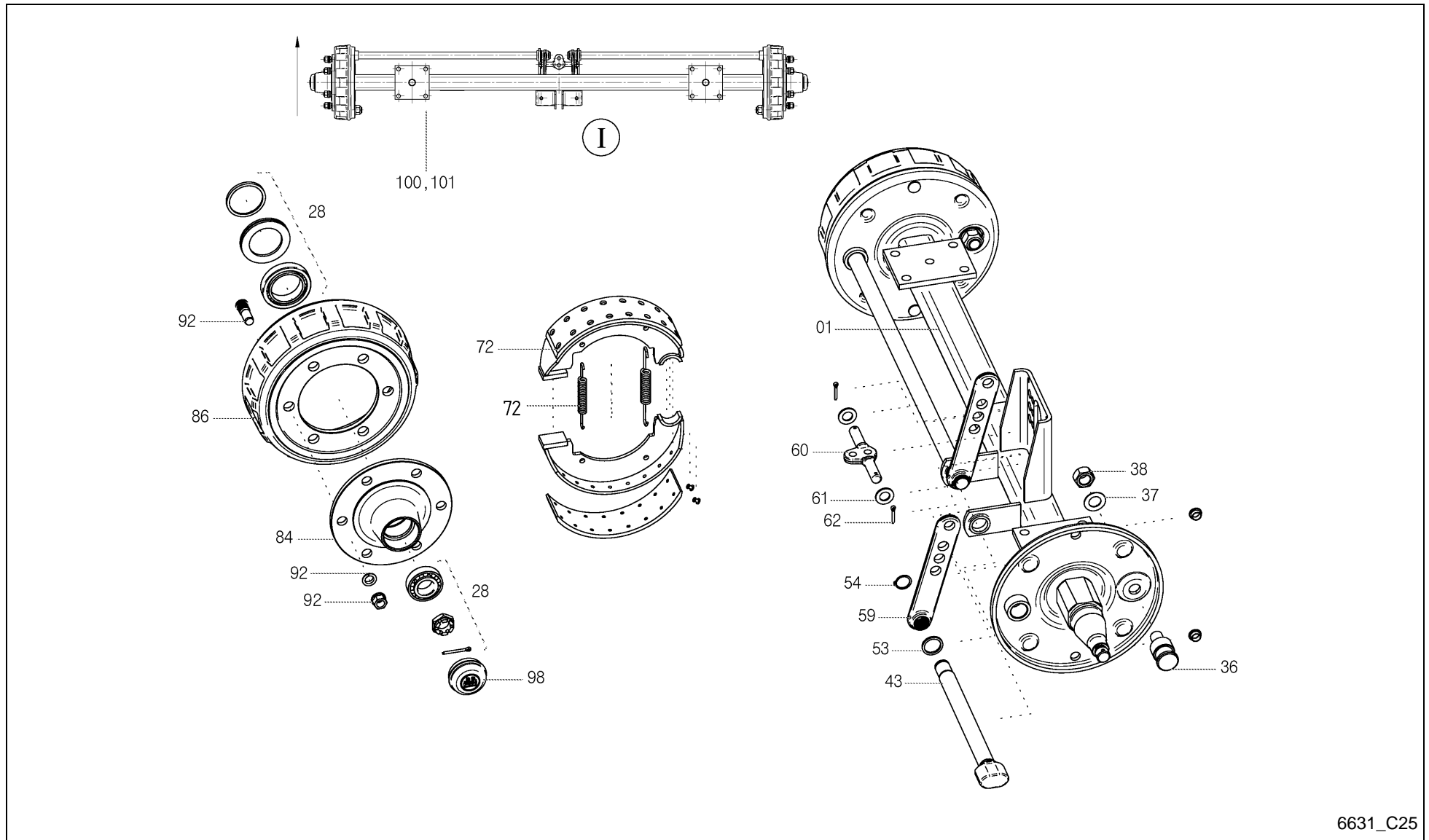

6631_C25

FeedMaster 3600T / BRAKE AXLE TANDEM HYDRAULIC ()



PosNo.	Part No.	Qty.	Description	Remark
I	VF16630080	1	BRAKING SPINDLE	
1	A143502900	1	AXLE BODY, GROUP	
28	A143503000	1	STORAGE PARTS SETS	
36	VF16602599	2	THREADED PIN	
37	VF16602600	2	WASHER	
38	A143503100	2	LOCK NUT VM24X1,5 DIN980	
43	A143503200	2	BRAKE CAMSHAFT L=750 / A=663	
53	A143503300	2	RING 42/34X4	
54	VF16618627	2	CIRCLIP	
59	A143503400	2	BRAKE LEVER	
60	VF03.110.02.140	1	BRAKE BALANCE	
61	A143475200	2	WASHER 21 DIN125	
62	VF01122071	2	SPLIT PIN 5,0X28 DIN94 A3C	
72	A143503600	1	BRAKE SHOE SET, KIT	
84	VF16617329.86	2	WHEEL HUB	
86	VF16617330.86	2	BRAKE DRUM	
92	A143503700	12	WHEEL STUD SET M18X57	
98	VF16612405	2	WHEEL CAP	
100	VF06273759	8	HEX. HEAD SCREW	
101	VF01112886	16	HEX. NUT	

FeedMaster 3600T / BRAKE AXLE TANDEM AUTOREVERSE ()



Lager und Dichtungen Trommelnabe
bearings and seals drum hub

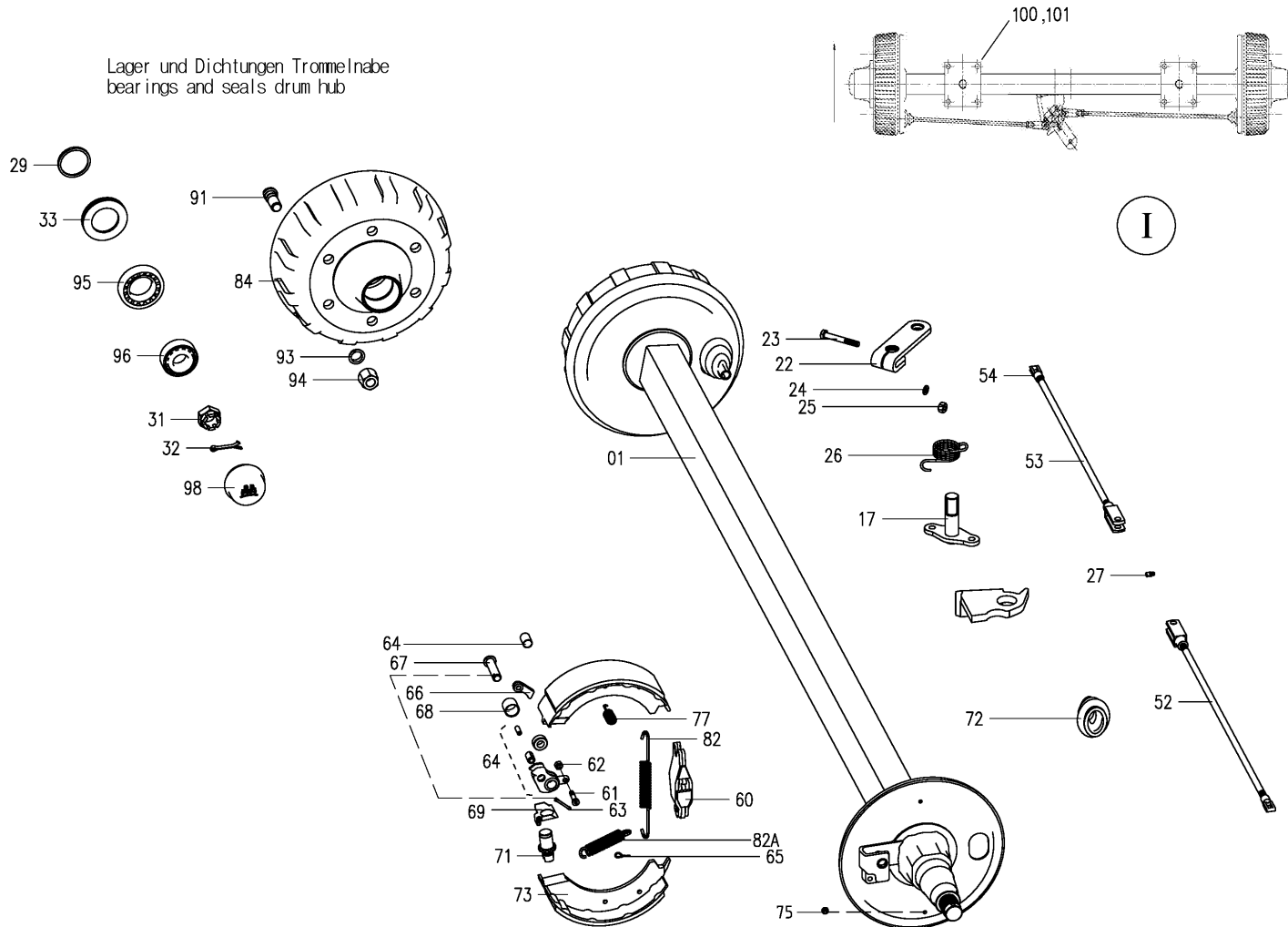

6631_C27

FeedMaster 3600T / BRAKE AXLE TANDEM AUTOREVERSE ()



PosNo.	Part No.	Qty.	Description	Remark
I	VF16630397	1	BRAKE AXLE	
1	A143506300	1	AXLE BODY, GROUP	
17	VF16612429	1	LEVER/ARM	
22	VF16612438	1	YOKE/RETAINER	
23	A143485400	1	HEXAGON HEAD SCREW M10X65 DIN931	
24	VF16612430	2	WASHER/DISC/PLATE	
25	A143507600	1	HEXAGONAL NUT M10 DIN934	
26	A143506400	1	SPRING	
27	VF16602619	1	GREASE NIPPLE	
27A	VF16602606	1	PROTECTING CAP	
29	VF16602597	2	RING	
31	VF16612406	2	CASTLE NUT	
32	A143507700	2	SPLIT PIN 5X45 ISO1234	
33	VF16602598	2	SEAL RING	
52	A143506500	1	BRAKE BAR GROUP L=590	
53	A143506600	1	BRAKE BAR GROUP L=715	
54	VF16618679	2	YOKE	
60	A143504300	2	LOCK EXPANDED	
61	A143504400	2	SCREW M8X35 DIN 7984	
62	A143459000	2	LOCK NUT M8 DIN985	
63	A143472600	2	SPLIT PIN 4X25 ISO1234	
64	A143504500	2	LEVER	
65	A143504700	4	FUSE	
66	A143504800	2	LEVER	
67	A143504900	2	BOLT B16X65 ISO2341	
68	A143505000	2	BUSH	
69	A143505200	2	FUSE	
71	A143505500	2	ADJUSTING NUT	
72	VF16503949	2	BELLOWS	
73	VF16612412	4	BRAKE SHOE	
75	A143458700	4	PLUG GPN 300 F5 M12	
77	A143505800	4	COMPRESSION SPRING	
81	A143505900	1	TENSION SPRING	
82	VF16503935	1	DRAW SPRING	
82A	A143506000	2	TENSION SPRING	
84	A143506100	2	DRUM HUB	
91	A143506200	12	WHEEL STUD M18X1,5X52	
93	VF16618602	12	SPRING WASHER	
94	VF16618603	12	FLAT-COLLAR NUT	
95	VF16602614	2	TAPER ROLLER BEARING.	

FeedMaster 3600T / BRAKE AXLE TANDEM AUTOREVERSE ()



Lager und Dichtungen Trommelnaabe
bearings and seals drum hub

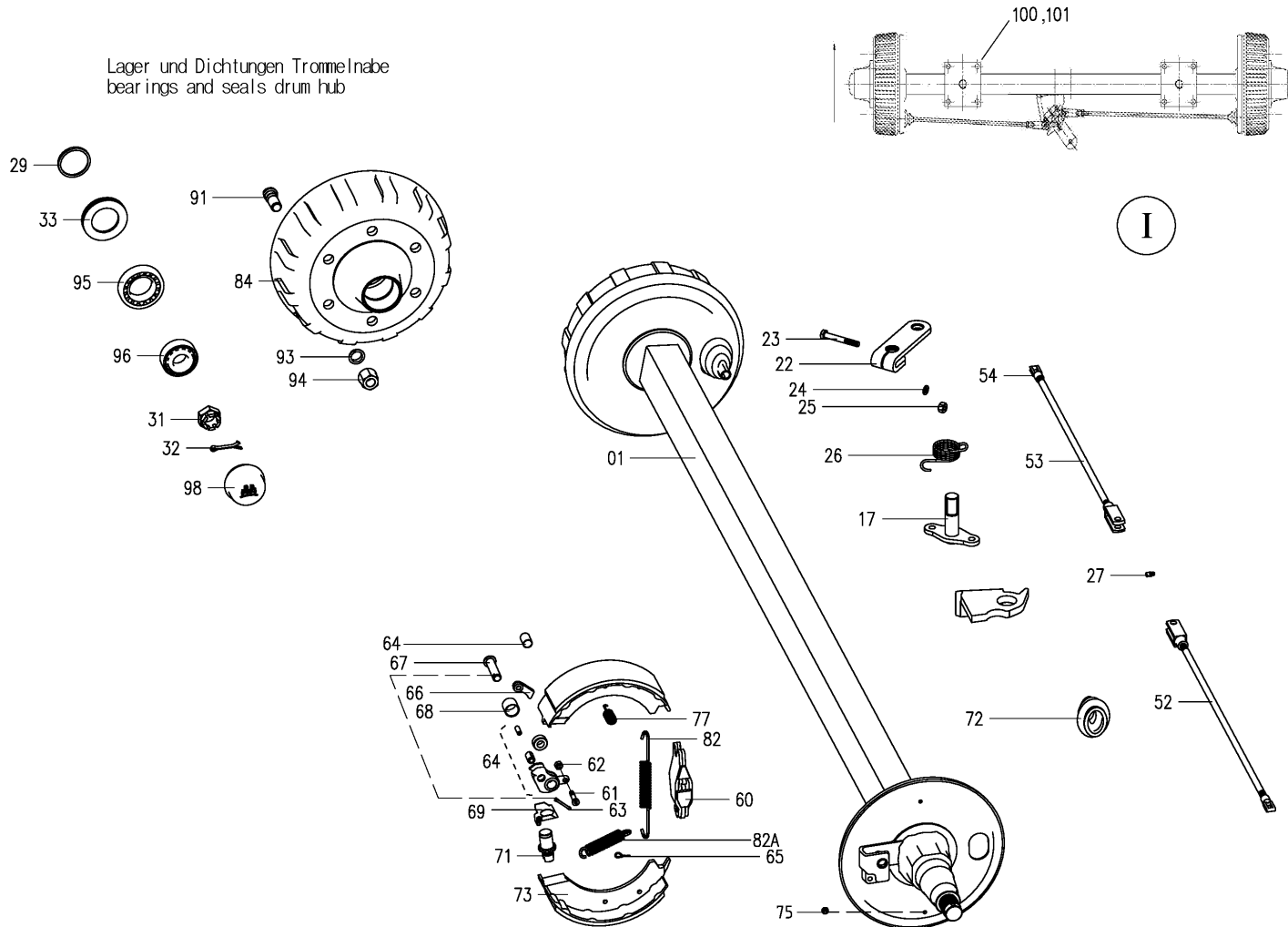

6631_C27

FeedMaster 3600T / BRAKE AXLE TANDEM AUTOREVERSE ()



PosNo.	Part No.	Qty.	Description	Remark
96	A143503800	2	TAPER ROLLER BEARING 30207	
98	VF16612405	2	WHEEL CAP	
100	VF06273759	8	HEX. HEAD SCREW	
101	VF01112886	16	HEX. NUT	

FeedMaster 3600T / BRAKE AXLE TANDEM PRESS AIR ()

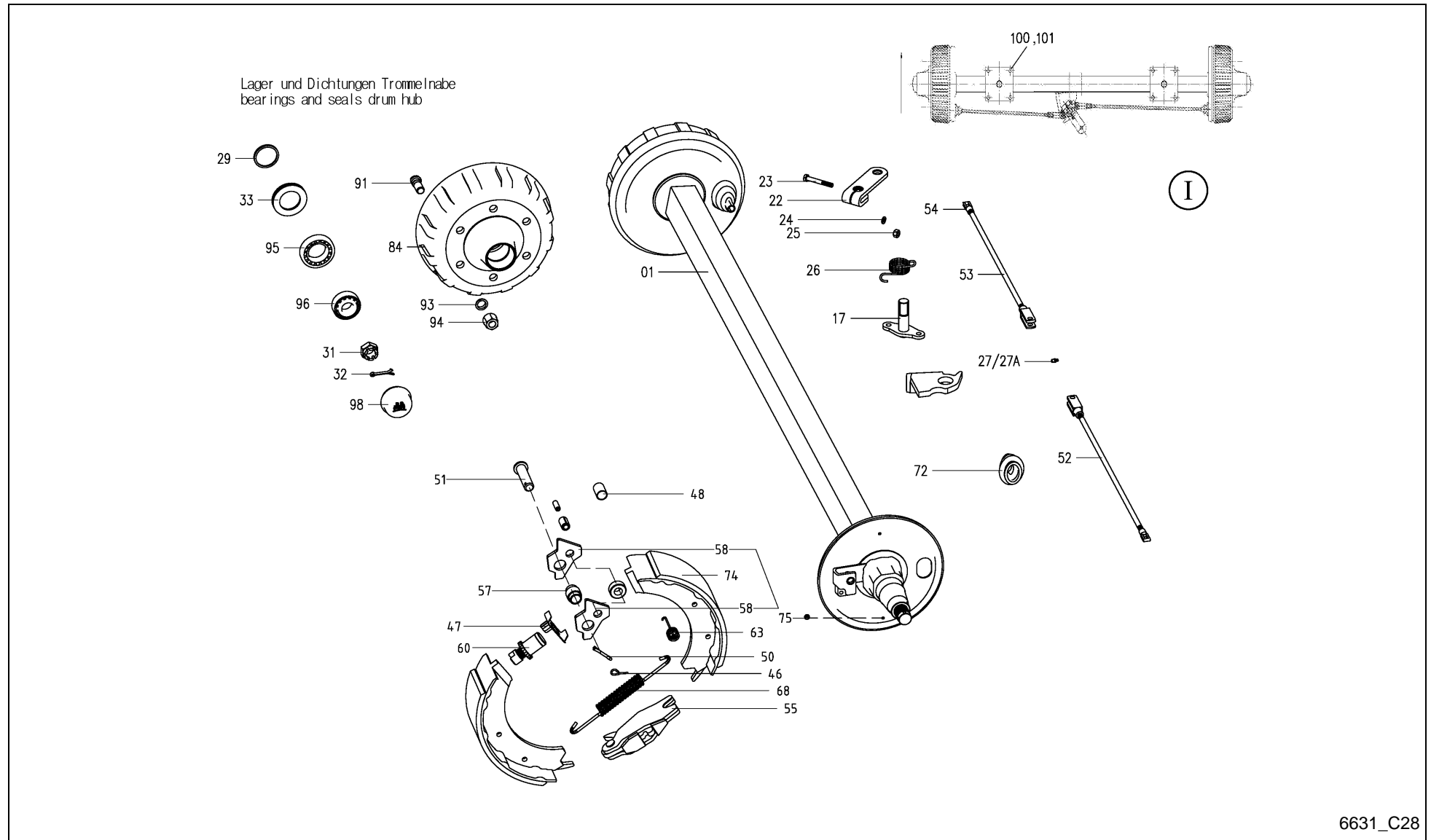

6631_C28

FeedMaster 3600T / BRAKE AXLE TANDEM PRESS AIR ()



PosNo.	Part No.	Qty.	Description	Remark
I	VF16630078	1	BRAKE AXLE	
1	A143506700	1	AXLE BODY, GROUP	
17	VF16612429	1	LEVER/ARM	
22	A143506800	1	BRAKE LEVER L100	
23	A143485400	1	HEXAGON HEAD SCREW M10X65 DIN931	
24	VF16612430	2	WASHER/DISC/PLATE	
25	A143507600	1	HEXAGONAL NUT M10 DIN934	
26	A143506400	1	SPRING	
27	VF16602619	1	GREASE NIPPLE	
27A	VF16602606	2	PROTECTING CAP	
29	VF16602597	2	RING	
31	VF16612406	2	CASTLE NUT	
32	A143507700	2	SPLIT PIN 5X45 ISO1234	
33	VF16602598	2	SEAL RING	
46	A143504700	2	FUSE	
47	A143505200	1	FUSE	
48	A143505000	1	BUSH	
50	A143472600	1	SPLIT PIN 4X25 ISO1234	
51	A143504900	1	BOLT B16X65 ISO2341	
52	A143506500	1	BRAKE BAR GROUP L=590	
53	A143506600	1	BRAKE BAR GROUP L=715	
54	VF16618679	2	YOKE	
55	A143504300	1	LOCK EXPANDED	
57	A143506900	1	BUSH	
58	A143507000	1	LEVER	
60	A143505500	1	ADJUSTING NUT	
63	A143505800	2	COMPRESSION SPRING	
65	A143458700	2	PLUG GPN 300 F5 M12	
68	A143505900	1	TENSION SPRING	
68A	VF16503935	1	DRAW SPRING	
72	VF16503949	1	BELLOWS	
74	VF16612412	2	BRAKE SHOE	
84	A143506100	2	DRUM HUB	
91	A143506200	12	WHEEL STUD M18X1,5X52	
93	VF16618602	12	SPRING WASHER	
94	VF16618603	12	FLAT-COLLAR NUT	
95	VF16602614	2	TAPER ROLLER BEARING.	
96	A143503800	2	TAPER ROLLER BEARING 30207	
98	VF16612405	2	WHEEL CAP	
100	VF06273759	1	HEX. HEAD SCREW	

FeedMaster 3600T / BRAKE AXLE TANDEM PRESS AIR ()

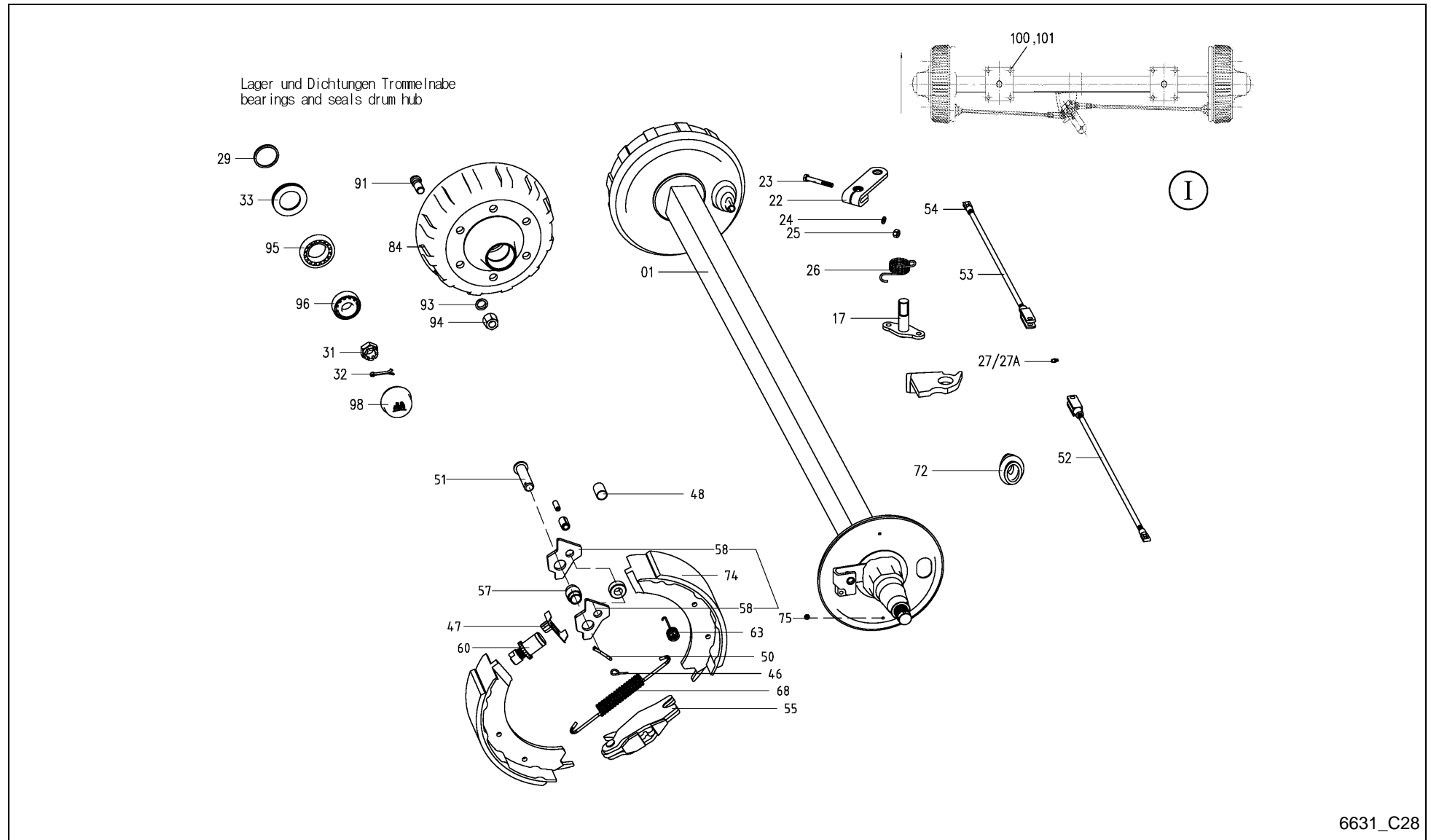

6631_C28

FeedMaster 3600T / BRAKE AXLE TANDEM PRESS AIR ()



PosNo.	Part No.	Qty.	Description	Remark
101	VF01112886	1	HEX. NUT	

FeedMaster 3600T / TANDEM-WHEEL AXLE HYDRAULIC ()

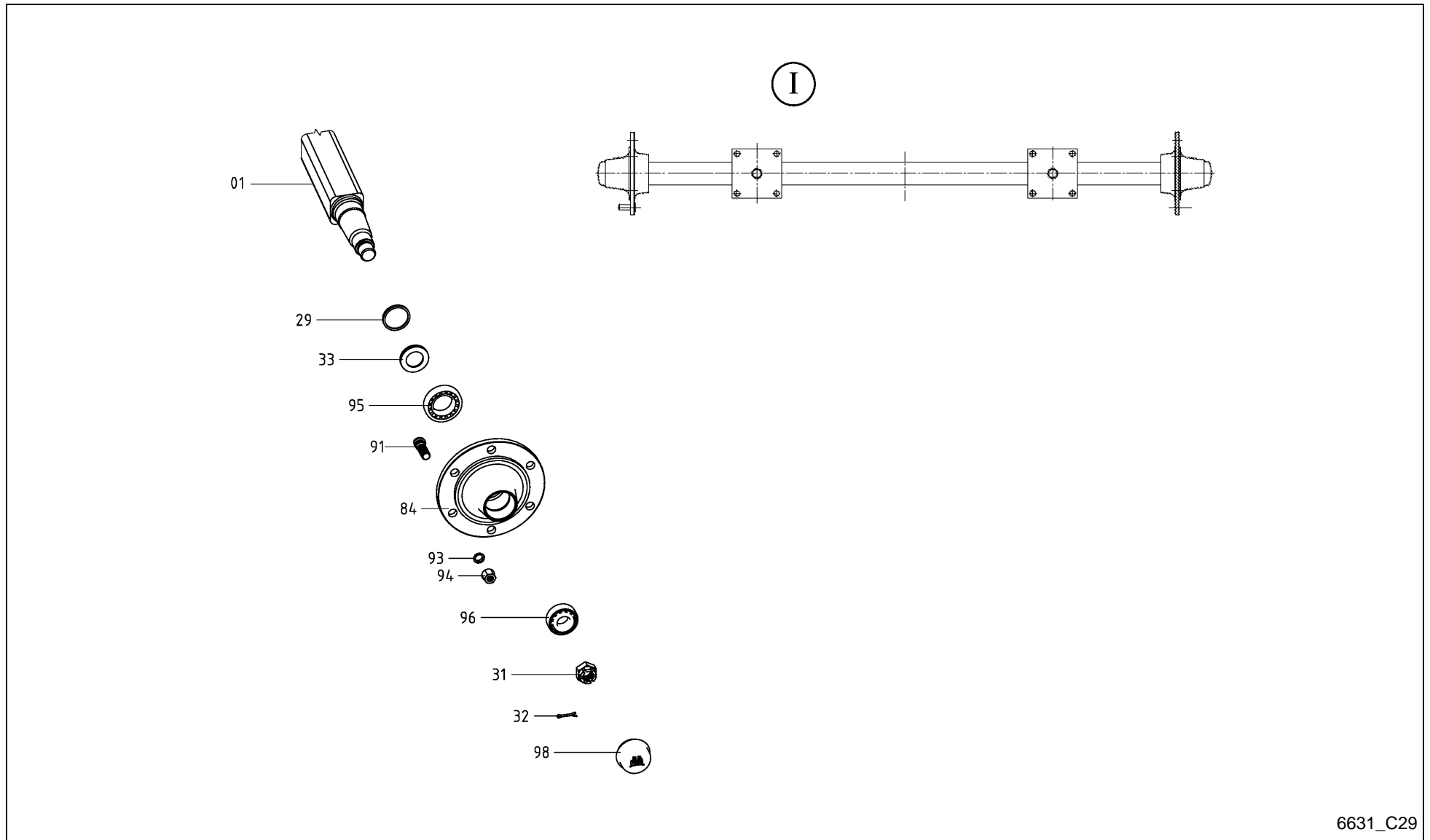

6631_C29

FeedMaster 3600T / TANDEM-WHEEL AXLE HYDRAULIC ()



PosNo.	Part No.	Qty.	Description	Remark
I	VF16630075	1	WHEEL AXLE	
1	A143507200	1	AXLE BODY,	
29	VF16602597	1	RING	
31	VF16612406	2	CASTLE NUT	
32	A143507700	2	SPLIT PIN 5X45 ISO1234	
33	VF16602598	2	SEAL RING	
84	VF16617329.86	2	WHEEL HUB	
91	A143507100	12	WHEEL STUD M18X1,5X46	
93	VF16618602	12	SPRING WASHER	
94	VF16618603	12	FLAT-COLLAR NUT	
95	VF16602614	2	TAPER ROLLER BEARING.	
96	A143503800	2	TAPER ROLLER BEARING 30207	
98	VF16612405	2	WHEEL CAP	

FeedMaster 3600T / HYDR. BRAKE SYSTEM FOR TANDEM AXLE 2-WHEELS BRAKED

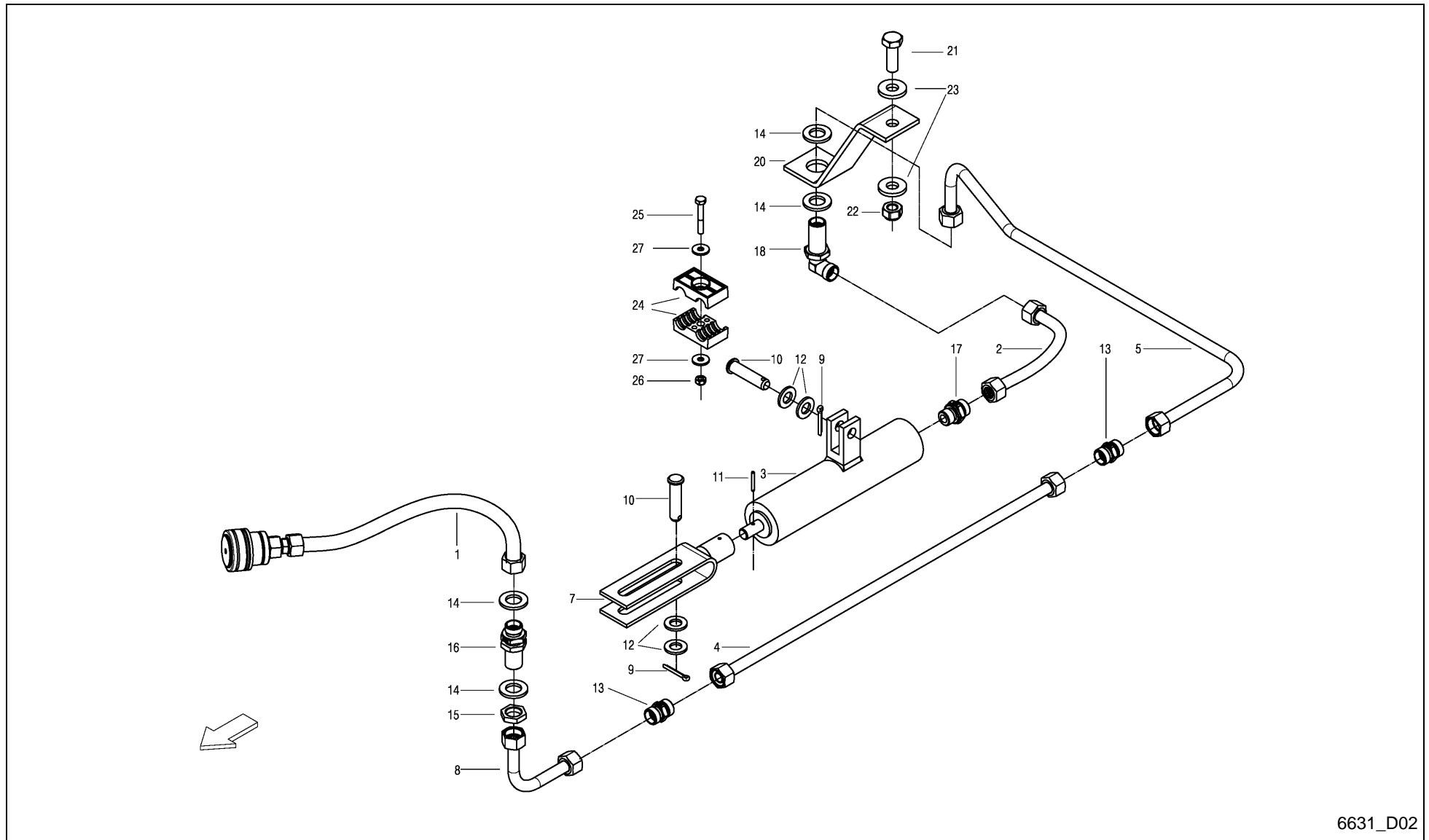

6631_D02

FeedMaster 3600T / HYDR. BRAKE SYSTEM FOR TANDEM AXLE 2-WHEELS BRAKED



PosNo.	Part No.	Qty.	Description	Remark
1	VF16613255	1	HYDR.HOSE	
2	VF16613337	1	HYDR.HOSE	
3	VF06587659	1	HYDR. CYLINDER	
4	VF16516426	1	HYDR.PIPE	
5	VF16610922	1	HYDR.PIPE	
7	VF16513900	1	CLEVIS	
8	VF16610994	1	HYDR.PIPE	
9	VF01106451	2	SPLIT PIN	
10	VF06210017	2	BOLT DIN1434-12H11X50X44	
11	KG01184962	1	TENSION PIN 3X24	
12	VF06214207	4	WASHER	
13	VF01116708	2	CONNECTING SLEEVE	
14	VF01124633	4	WASHER	
15	VF06216908	2	WHEEL NUT M 18X1,5 DIN80705	
16	VF01100600	1	STRAIGHT CONNECTOR XSV 12-L CF	
17	VF16611308	1	SOCKET XGE 12L-R3/8" CF	
18	VF01101288	1	BULKHEAD ELBOW XWSV 12L CF	
20	VF16513869	1	RETAINER	
21	VF01103341	1	HEX.HEAD SCREW	
22	VF06209769	1	LOCK NUT	
23	VF06214206	3	WASHER 13X30X4 RM=580-680 MPA A2C	
24	VF06578035	2	CLAMP	
25	VF01111071	1	HEX. HEAD SCREW	
26	VF01114357	1	LOCK NUT	
27	VF06214189	4	WASHER 6,4X18X2 A2C	

FeedMaster 3600T / HYDR. BRAKE SYSTEM FOR TANDEM AXLE 4-WHEELS BRAKED

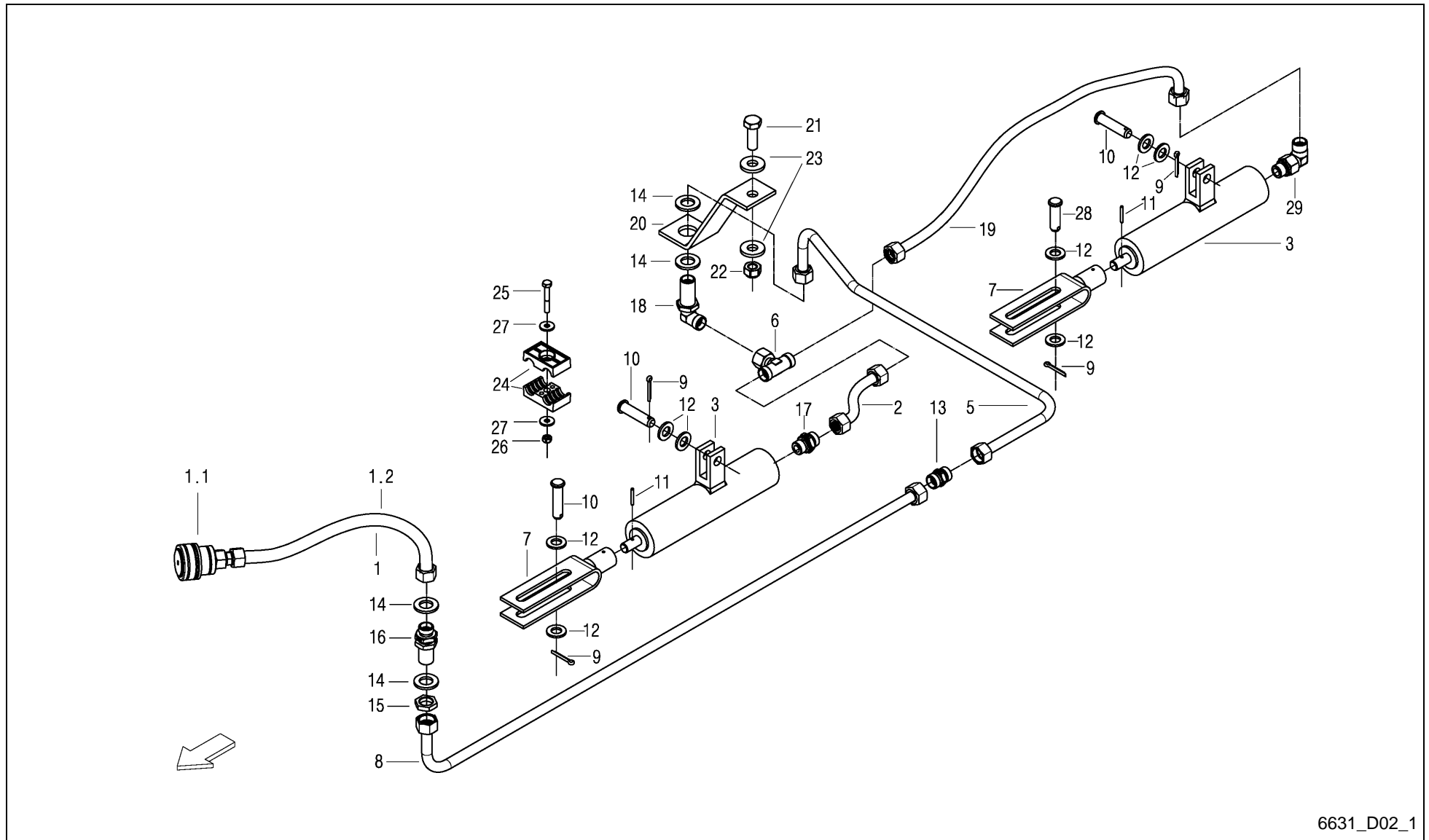

6631_D02_1

FeedMaster 3600T / HYDR. BRAKE SYSTEM FOR TANDEM AXLE 4-WHEELS BRAKED



PosNo.	Part No.	Qty.	Description	Remark
1	VF16613255	1	HYDR.HOSE	
1.1	VF16613256	1	HYDR.PIPE IG M 18X1,5 ISO 56	
1.2	VF06554678	1	HYDR. HOSE 0BODN10X2500 DKOL-12L	
2	VF16613337	1	HYDR.HOSE	
3	VF16518038	2	CYLINDER	
4	VF16516426	1	HYDR.PIPE	
5	VF16610922	1	HYDR.PIPE	
6	VF16631272	1	NOZZLE	
7	VF16513900	2	CLEVIS	
8	VF16610994	1	HYDR.PIPE	
9	VF01106451	4	SPLIT PIN	
10	VF06210017	3	BOLT DIN1434-12H11X50X44	
11	KG01184962	1	TENSION PIN 3X24	
12	VF06214207	8	WASHER	
13	VF01116708	2	CONNECTING SLEEVE	
14	VF01124633	4	WASHER	
15	VF06216908	2	WHEEL NUT M 18X1,5 DIN80705	
16	VF01100600	1	STRAIGHT CONNECTOR XSV 12-L CF	
17	VF16611308	1	SOCKET XGE 12L-R3/8" CF	
18	VF01101288	1	BULKHEAD ELBOW XWSV 12L CF	
19	VF16631271	1	HYDR. HOSE	
20	VF16513869	1	RETAINER	
21	VF01103341	1	HEX.HEAD SCREW	
22	VF06209769	1	LOCK NUT	
23	VF06214206	3	WASHER 13X30X4 RM=580-680 MPA A2C	
24	VF06578035	2	CLAMP	
25	VF01111071	1	HEX. HEAD SCREW	
26	VF01114357	1	LOCK NUT	
27	VF06214189	4	WASHER 6,4X18X2 A2C	
28	VF06210015	1	PIN	
29	VF16631273	1	ANGLE UNION	

FeedMaster 3600T / COMPRES.AIR SYSTEM SPRUNG TANDEM AXLE_SINGLE AXIS

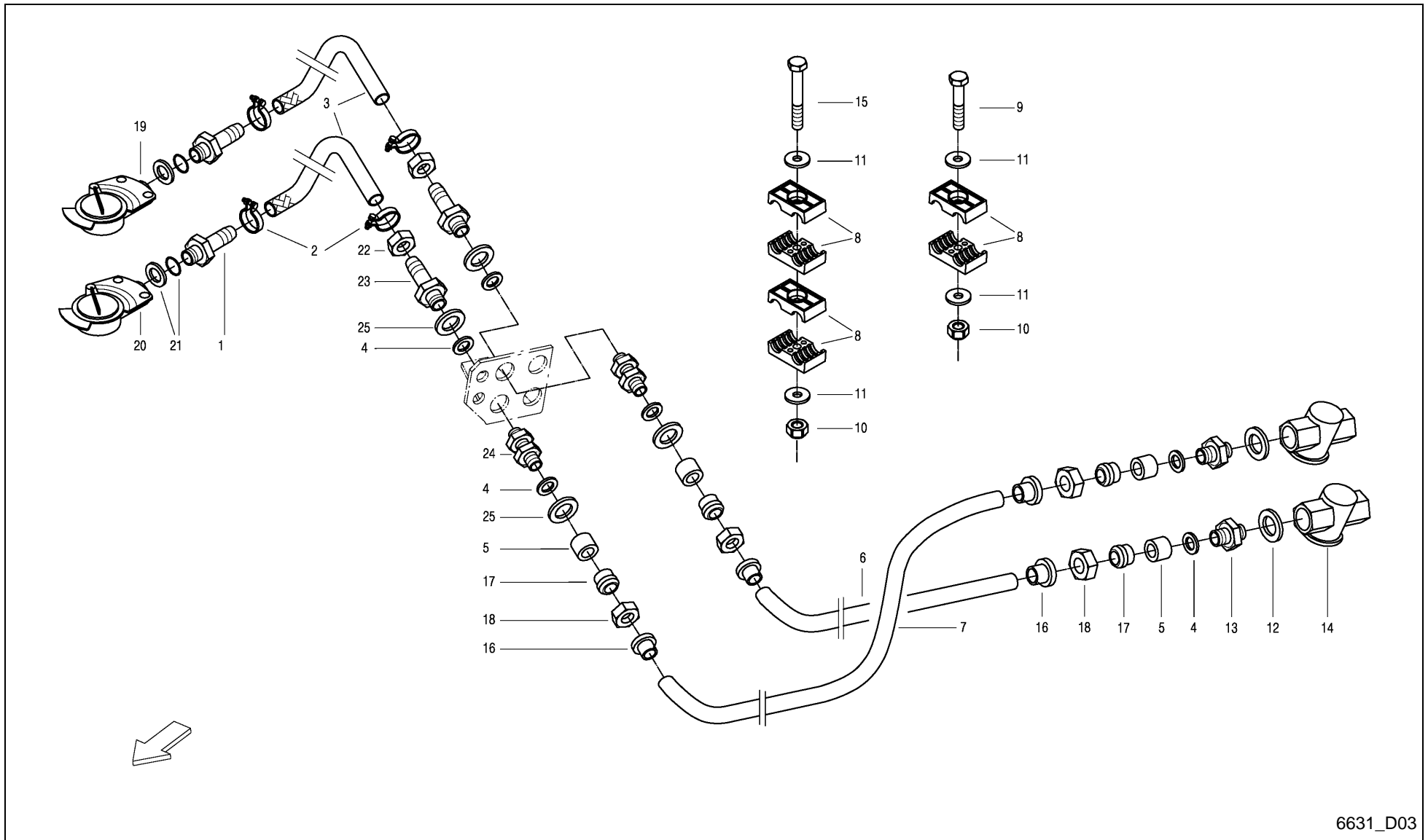

6631_D03

FeedMaster 3600T / COMPRES.AIR SYSTEM SPRUNG TANDEM AXLE_SINGLE AXIS



PosNo.	Part No.	Qty.	Description	Remark
1	VF06216771	2	TUBE	
2	VF06216772	4	HOSE CLAMP WEDTH 15	
3	VF06558991	2	BRAKE TUBE	
4	VF06277296	6	SEAL RING A12X19X1,5 VF	
5	VF01125146	6	THRUST RING DIN3867-AL15	
6	VF16630506	1	PLASTIC TUBE	
7	VF16630507	1	PLASTIC TUBE	
8	VF06578035	6	CLAMP	
9	VF01122389	1	HEX.HEAD SCREW	
10	VF01114357	3	LOCK NUT	
11	VF06214189	3	WASHER 6,4X18X2 A2C	
12	VF01118736	2	SEAL RING A22X27DIN7603-AL	
13	VF01142247	2	NOZZLE XGEB16M22D13	
14	VF06558801	2	FILTER M22X1,5	
15	VF01126974	2	HEX. HEAD SCREW	
16	VF02953369	4	PLUG-IN SLEEVE	
17	VF01116626	4	CUTTING RING D15L DIN 3861 ST A3C	
18	VF01125152	4	UNION NUT L15 DIN3872	
19	VF16630646	1	COUPLING HEAD, YELLOW	
20	VF16630647	1	COUPLING HEAD, RED	
21	VF06216757	2	SEAL RING DRM22	
22	VF01142083	2	UNION NUT BLL15DIN3870	
23	VF01121766	2	TUBE DIN74304-A	
24	VF06216763	2	TWIN NOZZEL XGS15M22D99+SM	
25	VF06214307	4	WASHER	

FeedMaster 3600T / COMPRESSED AIR SYSTEM TANDEM AXLE SPRING BORN

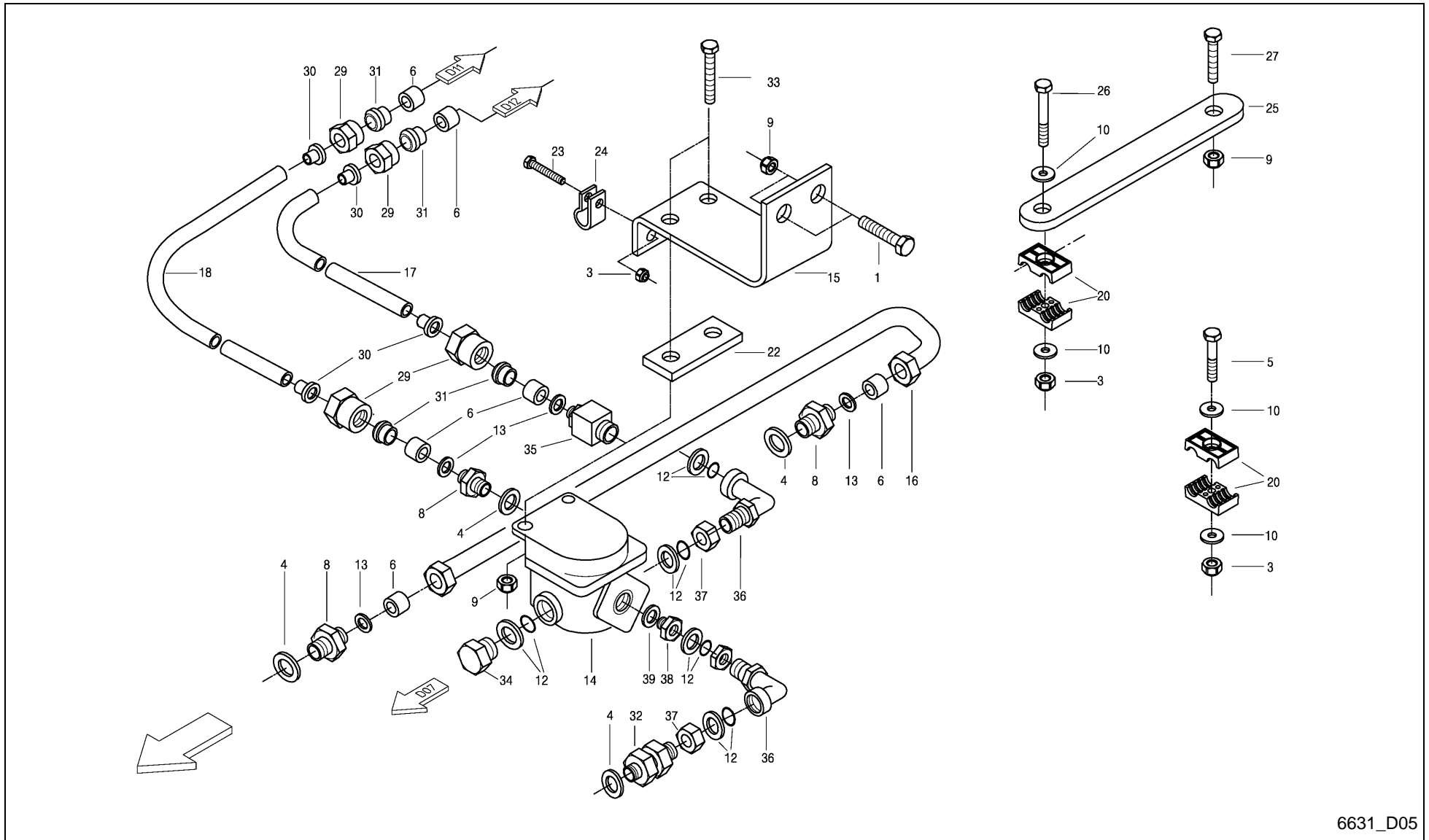

6631_D05

FeedMaster 3600T / COMPRESSED AIR SYSTEM TANDEM AXLE SPRING BORN



PosNo.	Part No.	Qty.	Description	Remark
1	VF01112429	2	HEX. HEAD SCREW	
3	VF01114357	3	LOCK NUT	
4	VF01118736	4	SEAL RING A22X27DIN7603-AL	
5	VF01122389	2	HEX.HEAD SCREW	
6	VF01125146	6	THRUST RING DIN3867-AL15	
8	VF01142247	3	NOZZLE XGEB16M22D13	
9	VF06209768	4	LOCK NUT	
10	VF06214189	4	WASHER 6,4X18X2 A2C	
12	VF06216757	5	SEAL RING DRM22	
13	VF06277296	6	SEAL RING A12X19X1,5 VF	
14	VF16519102	1	BRAKE VALVE	
15	VF16630254	1	BRACKET	+A 2000
16	VF16518934	1	BRAKE TUBE	
17	VF16519107	1	PLASTIC TUBE	
18	VF16519106	1	PLASTIC TUBE	
20	VF06578035	3	CLAMP	
22	VF16518084	1	SHIM	
23	VF01103316	1	HEX. HEAD SCREW	
24	VF01211882	1	PIPE CLIP RSGU1 15X15	
25	VF16518926	1	RETAINER	
26	VF01102664	1	HEX HEAD SCREW	
27	VF01112439	1	HEX. HEAD SCREW	
29	VF01125152	4	UNION NUT L15 DIN3872	
30	VF02953369	4	PLUG-IN SLEEVE	
31	VF01116626	4	CUTTING RING D15L DIN 3861 ST A3C	
32	VF06216763	1	TWIN NOZZEL XGS15M22D99+SM	
33	VF01112447	2	HEX.HEAD SCREW	
34	VF06216756	1	BANJO BOLT HS15D05	
35	VF06216762	1	STRAIGHT UNION	
36	VF16615011	2	ANGLE PIECE	
37	VF01137633	3	WHEEL NUT M22 X 1,5 DIN80705 A2C	
38	VF02953368	1	REDUCING SOCKET	
39	VF01118699	1	SEALING WASHER	

FeedMaster 3600T / COMPRESSED AIR SYSTEM TANDEM AXLE SPRING BORN

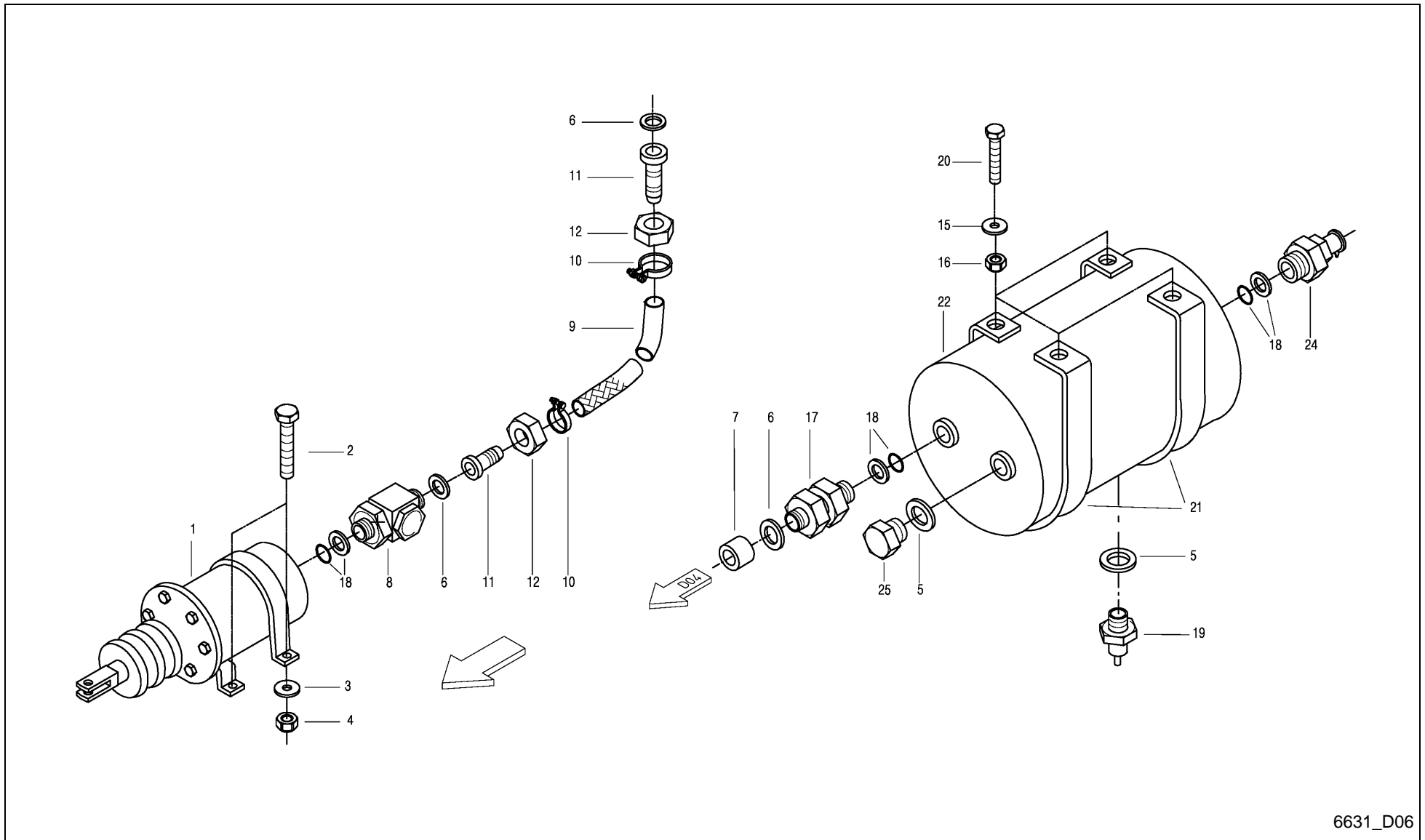

6631_D06

FeedMaster 3600T / COMPRESSED AIR SYSTEM TANDEM AXLE SPRING BORN



PosNo.	Part No.	Qty.	Description	Remark
1	VF16513522	1	AIR CYLINDER	
2	VF01103341	4	HEX.HEAD SCREW	
3	VF06214206	4	WASHER 13X30X4 RM=580-680 MPA A2C	
4	VF06209778	4	LOCK NUT	
5	VF01118736	2	SEAL RING A22X27DIN7603-AL	
6	VF06277296	3	SEAL RING A12X19X1,5 VF	
7	VF01125146	3	THRUST RING DIN3867-AL15	
8	VF06216762	1	STRAIGHT UNION	
9	VF06558992	1	BRAKE TUBE	
10	VF06216772	2	HOSE CLAMP WEDTH 15	
11	VF01121766	1	TUBE DIN74304-A	
12	VF01142083	1	UNION NUT BLL15DIN3870	
15	VF06214197	6	WASHER 10,5X30X3 GALV.	
16	VF06209768	4	LOCK NUT	
17	VF06216763	1	TWIN NOZZEL XGS15M22D99+SM	
18	VF06216757	5	SEAL RING DRM22	
19	VF06216747	1	BLEED VALVE EV-C15D92 M.R.	
20	VF01112439	4	HEX. HEAD SCREW	
21	VF16513677	2	CLAMPING YOKE	
22	VF06216745	1	AIR TANK	
24	VF01142023	1	BANJO BOLT WITH TEST CONNECTION	
25	VF06216756	1	BANJO BOLT HS15D05	

FeedMaster 3600T / PRESS.AIR BRAKE WITH AUTOM.LOAD-SENSING VALVE

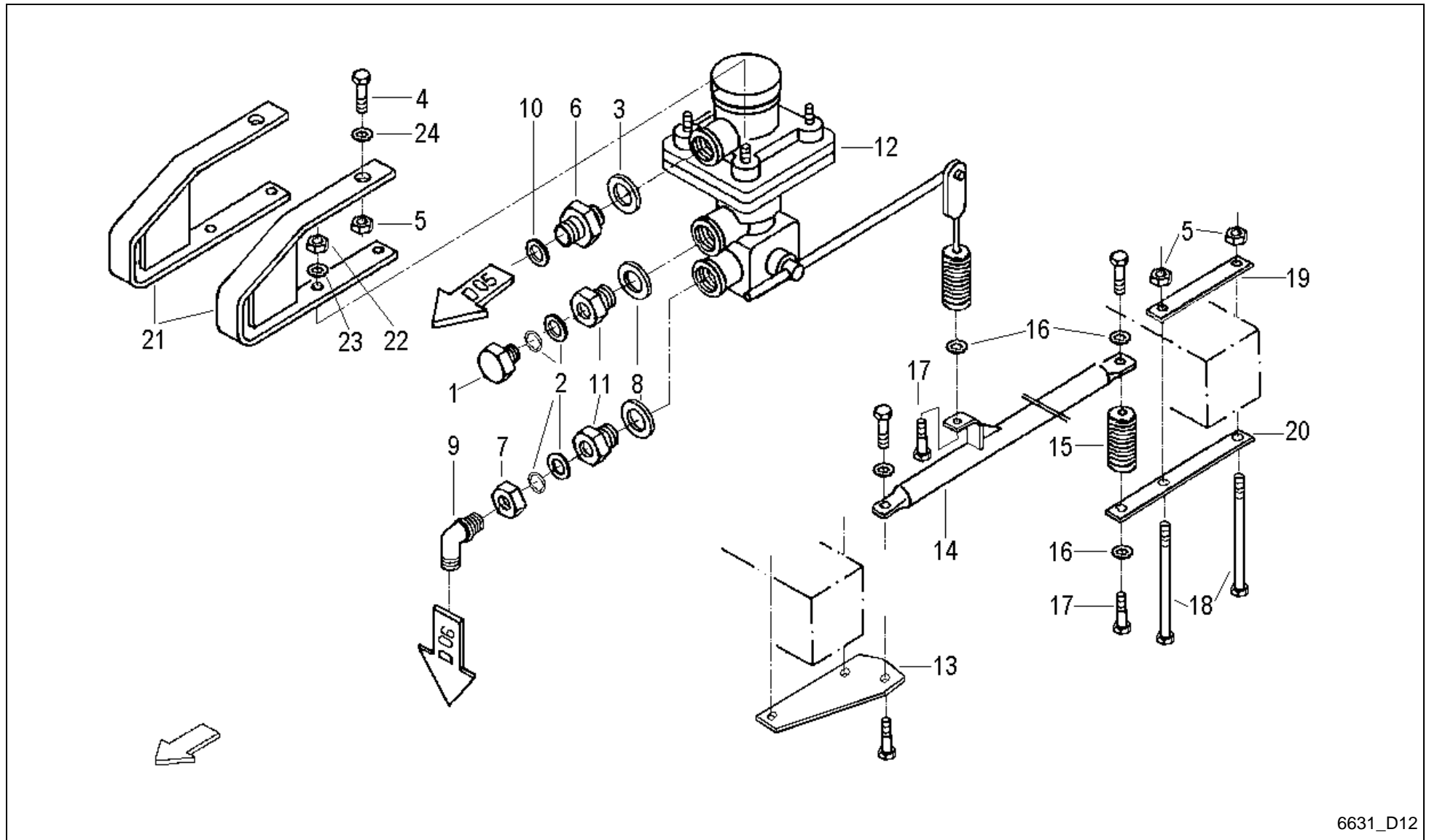

6631_D12

FeedMaster 3600T / PRESS.AIR BRAKE WITH AUTOM.LOAD-SENSING VALVE



PosNo.	Part No.	Qty.	Description	Remark
1	VF06216756	1	BANJO BOLT HS15D05	
2	VF06216757	2	SEAL RING DRM22	
3	VF01118736	1	SEAL RING A22X27DIN7603-AL	
4	VF01112439	2	HEX. HEAD SCREW	
5	VF06209768	4	LOCK NUT	
6	VF01142247	2	NOZZLE XGEB16M22D13	
7	VF01137633	1	WHEEL NUT M22 X 1,5 DIN80705 A2C	
8	VF01118699	2	SEALING WASHER	
9	VF01142246	1	ELBOW M22 (HALDEX 032018509)	
10	VF06277296	1	SEAL RING A12X19X1,5 VF	
11	VF02953368	2	REDUCING SOCKET	
12	VF16615010	1	LOAD-SENSING VALVE	
13	VF16630231	1	CONNECTING PLATE	
14	VF16614984	1	CONNECTING PIPE	
15	VF16615012	2	SPRING STOP	
16	VF01102800	5	SPRING WASHER	
17	VF01112418	5	BOLT, SCREW	
18	VF01111352	2	HEX.HEAD SCREW	
19	VF16615013	1	RETAINER	
20	VF16615014	1	RETAINER	
21	VF16614995	2	RETAINER	
22	VF01104944	4	NY LOCK NUT 8A3CD985	
23	VF01107163	4	WASHER	
24	VF01107165	2	WASHER M10 11X20X2 A2C DIN126	

FeedMaster 3600T / HYDR.SCRAPER FLOOR+TAILGATE

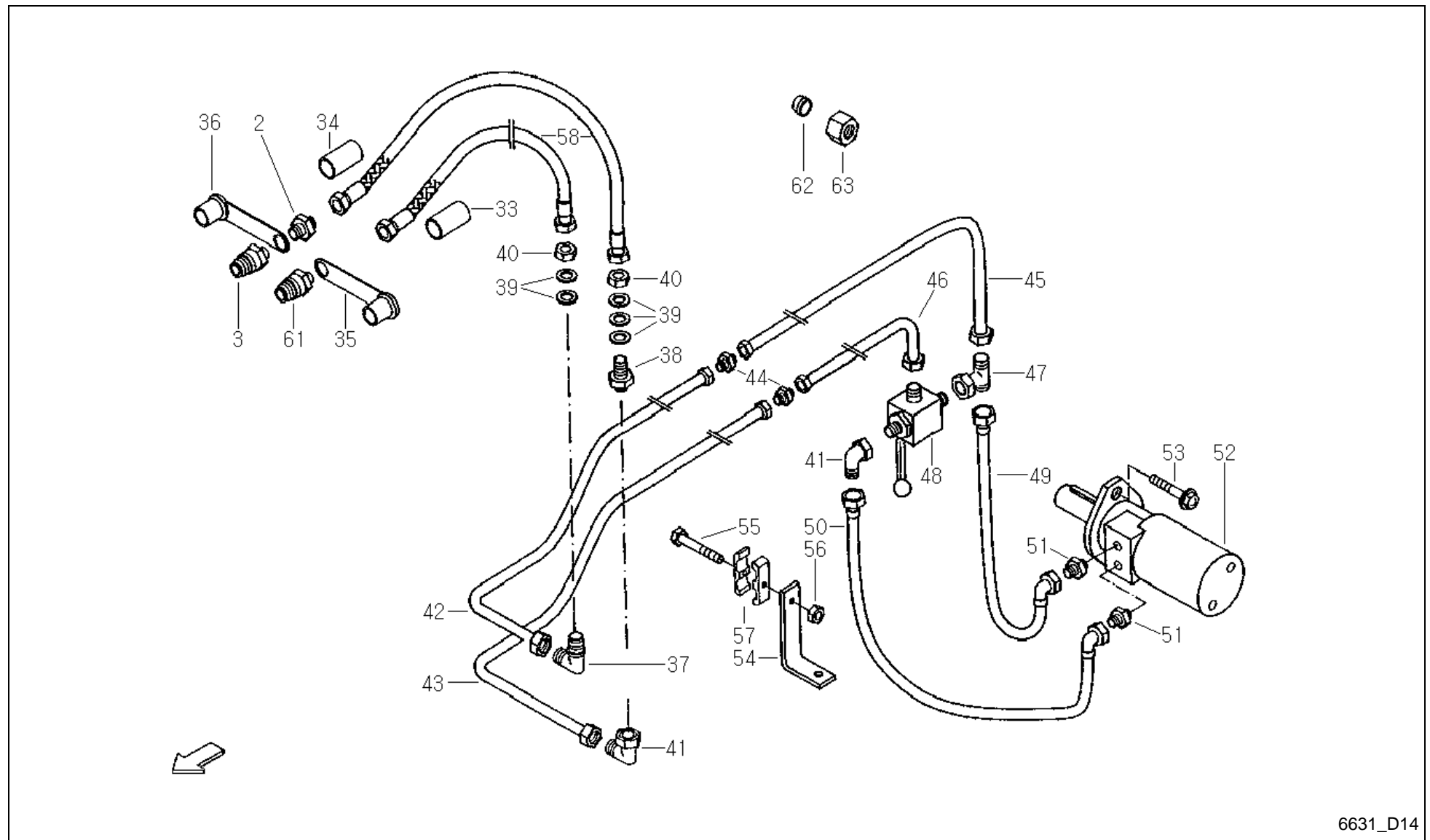

6631_D14

FeedMaster 3600T / HYDR.SCRAPER FLOOR+TAILGATE



PosNo.	Part No.	Qty.	Description	Remark
2	VF01397770	1	CHECK VALVE	
3	VF16613435	1	SAFETY PIN	
33	VF16515428	1	SHRINK TUBE RED 25X50	
34	VF16513948	1	SHRINK TUBE YELLOW 25X50	
35	VF01142006	1	DUST CAP	
36	VF06571341	1	DUST CAP BLACK 27MM DIAMETER	
37	VF01116758	1	TWO-WAY CONNECTOR	
38	VF01133922	1	NOZZLE AL15 D3910 GALV.	
39	VF06214306	5	WASHER 23X38X2 GALV. HV200	
40	VF01137633	2	WHEEL NUT M22 X 1,5 DIN80705 A2C	
41	VF16613433	2	ANGLE UNION	
42	VF16613439	1	HYDR,PIPE	
43	VF16613441	1	HYDR.PIPE	
44	VF01116710	2	CONNECTING SLEEVE	
45	VF16613443	1	HYDR.PIPE	
46	VF16613445	1	HYDR.PIPE	
47	VF16613434	1	T-CONNECTOR XET 15-L GALV.	
48	VF16613436	1	ROOSTER	
49	VF16613446	1	HYDR.HOSE	
50	VF16613447	1	HYDR.HOSE	
51	VF06216836	2	SOCKET XGE 15LR-ED CF	
52	VF16613240	1	HYDR. MOTOR MF160 VORM.	1663 0885 + 1661 3239
52.1	VF16630888		DICHTSATZ FÜR TORQMOTOR MOTOR MF 165	für Motor MF 165
52.2	VF16630889		DICHTSATZ FÜR HYDR.MOTOR EPM 160CD	für Hydraulikmotor EPM
52.3	VF16630900		SEALING KIT HYDR. ENGINE	für Hydraulikmotor EPRM
53	VF06214156	2	SCREW	
54	VF16613380	2	BRACKET	
55	VF01122389	6	HEX.HEAD SCREW	
56	VF01114357	6	LOCK NUT	
57	VF06578035	12	CLAMP	
58	VF16610873	2	HYDR.HOSE	
61	VF06571330	1	HOSE CONNECTION NW10, IG M 22X1,5	
62	VF01116626		CUTTING RING D15L DIN 3861 ST A3C	
63	VF01116653		UNION NUT H3105-CL15-ST- GALV.	

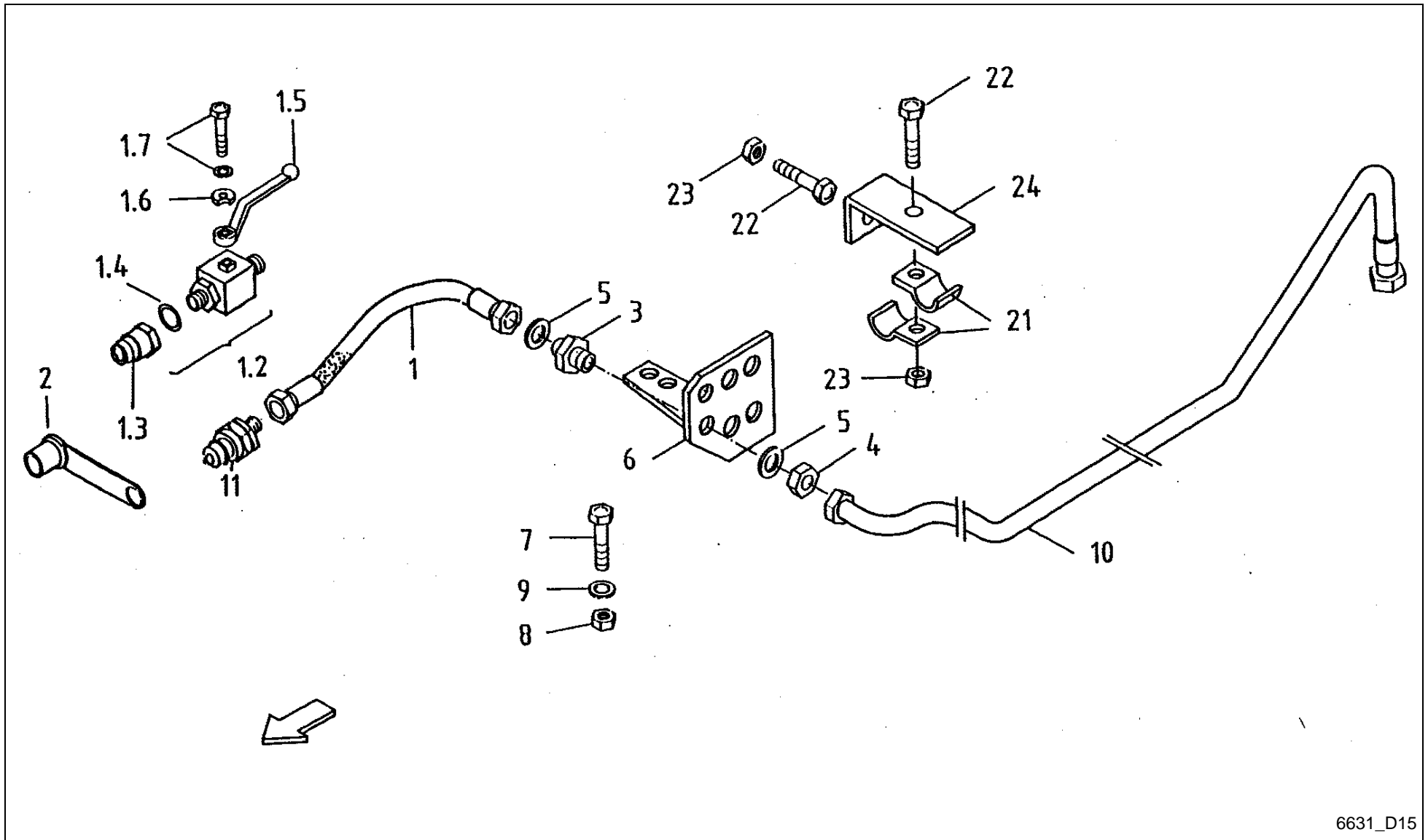

FeedMaster 3600T / HYDR. INSTALLATION BASIC CONTENT



PosNo.	Part No.	Qty.	Description	Remark
1	VF06582530	1	HYDR. HOSE 0BODN6X2500 DKOL-8L+DKOL-8L	
1	VF06582524	1	CLUTCH HOSE	-450
1.2	VF16604641	1	BALL VALVE W. CONNECTOR NW10	-450
1.3	VF16604726	1	SAFETY PIN FOR PISTE BALL VALVE 10L	-450
1.4	VF16604727	1	SEALING WASHER	-450
1.5	VF16604728	1	SHIFT LEVER	-450
1.6	VF16604729	1	SHIFT WASHER	-450
1.7	VF16604730	1	RIPP SCREW M 5X 8	-450
2	VF06571341	1	DUST CAP BLACK 27MM DIAMETER	
3	VF01123941	1	STRAIGHT CONNECTOR XSV 8-L CF	
4	VF01121824	1	NUT M14X1,5 GM08L CF	
5	VF06214202	2	WASHER 14X24X1,6 GALV.	
6	VF16518890	1	PLATE	
7	VF01112418	2	BOLT, SCREW	
8	VF06209768	2	LOCK NUT	
9	VF01107103	4	WASHER/DISC/PLATE	
10	VF16613449	1	HYDR.PIPE	S D21
11	VF16615171	1	PLUG CONTACT DN 10 EXTE. THREAD M 14X1,5	+451
21	VF06216397	2	FIXING CLIP	
22	VF01112264	2	HEX. HEAD SCREW	
23	VF01114357	2	LOCK NUT	
24	VF16613364	1	BRACKET	

FeedMaster 3600T / HYDR. FOR REAR GATE

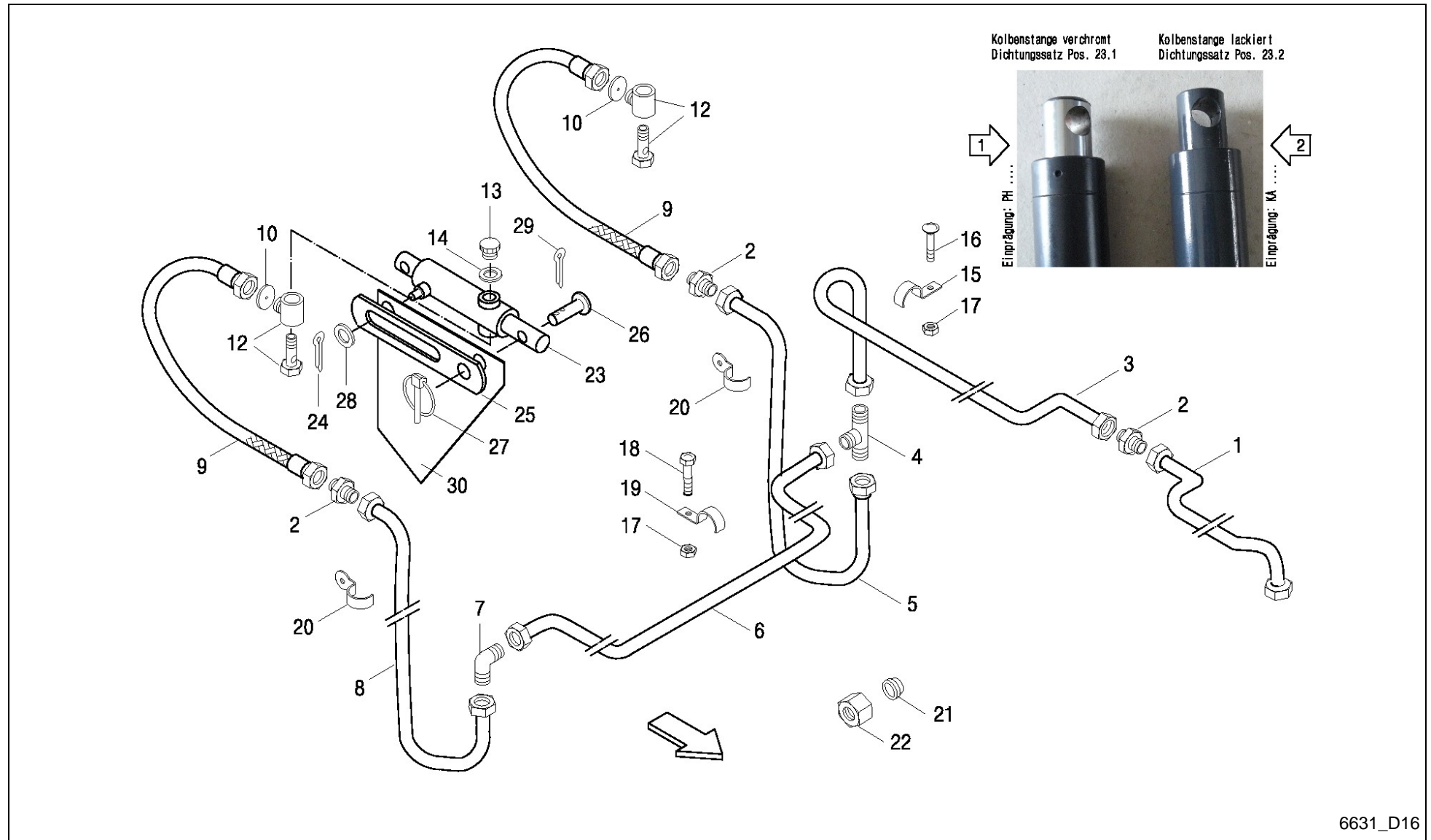

6631_D16

FeedMaster 3600T / HYDR. FOR REAR GATE



PosNo.	Part No.	Qty.	Description	Remark
1	VF16613313	1	HYDR.PIPE	
2	VF01116705	2	CONNECTING SLEEVE XG 8-L CF	
3	VF16613315	1	HYDR. PIPE	
4	VF01116740	1	NOZZLE XT 8-L GALV.	
5	VF16613319	1	HYDR.PIPE	
6	VF16613317	1	HYDR.PIPE	
7	VF01116731	1	SOCKET D3905 L 8 W08LCFX	
8	VF16613321	1	HYDR.PIPE	
9	VF16613311	2	HYDR.HOSE	
10	VF06577567	2	WASHER	
12	VF16631123	2	UNION 2 PIECE	
13	VF01143104	2	SCREW PLUG	
14	VF16611312	2	SEALING RING	
15	VF06216397	6	FIXING CLIP	
16	VF01142077	6	SAUCER HEAD SCREW	
17	VF01114357	9	LOCK NUT	
18	VF01123749	3	HEX. HEAD SCREW	
19	VF06258500	3	PIPE CLIP	
20	VF06216396	4	HOSE CLIP	
21	VF01116622		CUTTING RING D08L DIN 3861-ST	
22	VF01127346		UNION NUT H3105-CL 8-ST A3C	
23	VF16630658	2	HYDR. CYLINDER 30X300	E 16515933
23.1	VF16630657		SEALING SET	E 16516843
23.2	A143501400		SEAL KIT	
24	VF01122072	2	SPLIT PIN	
25	VF16515976	2	LIFT LIMIT	
26	VF16515987	2	PIN/BOLT/STUD	
27	VF16611321	2	LYNCH PIN 4X27 DIN1 1023 GALV.	
28	VF01107121	2	WASHER	
29	VF01106451	2	SPLIT PIN	
30	VF16611382	2	GUARD PLATE	

FeedMaster 3600T / HYDR. FOR PICK-UP

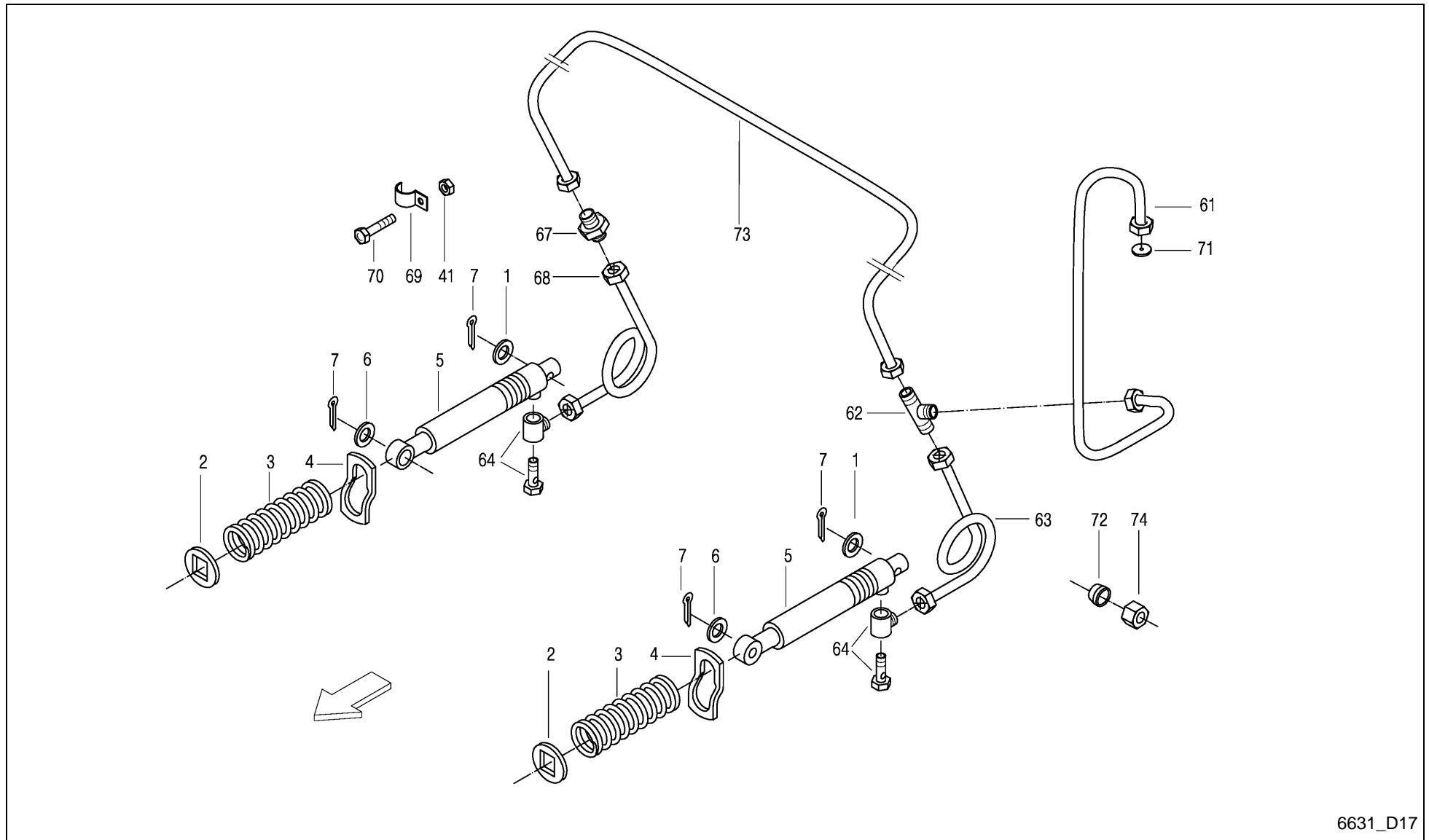

6631_D17

FeedMaster 3600T / HYDR. FOR PICK-UP



PosNo.	Part No.	Qty.	Description	Remark
1	KG01273861	2	WASHER DIN7349 M14 A3C	
2	VF16519184	2	WASHER/DISC/PLATE	
3	VF06215425	2	COMPRESSION SPRING	
4	VF06576503	2	CLIP	
5	VF16514629	2	CYLINDER, HYDR.	
5	VF16504079		SEALING SET	
6	VF06214585	2	WASHER	
7	VF01106451	4	SPLIT PIN	
41	VF01114357	6	LOCK NUT	
61	VF16517194	1	HYDR.PIPE	S D21
62	VF01116740	1	NOZZLE XT 8-L GALV.	
63	VF06577864	1	HYDR.PIPE	
64	VF16631123	2	UNION 2 PIECE	
68	VF16613306	1	HYDR.HOSE	
69	VF06216397	6	FIXING CLIP	
70	VF01112264	6	HEX. HEAD SCREW	
71	VF06581181	1	RESTRICTOR 1,0 MM D8,0X1	
72	VF01116622		CUTTING RING D08L DIN 3861-ST	
73	VF16613325	1	HYDR.HOSE	
74	VF01127346		UNION NUT H3105-CL 8-ST A3C	

FeedMaster 3600T / HYDR. FOR DRY FORAGE SUPERST.

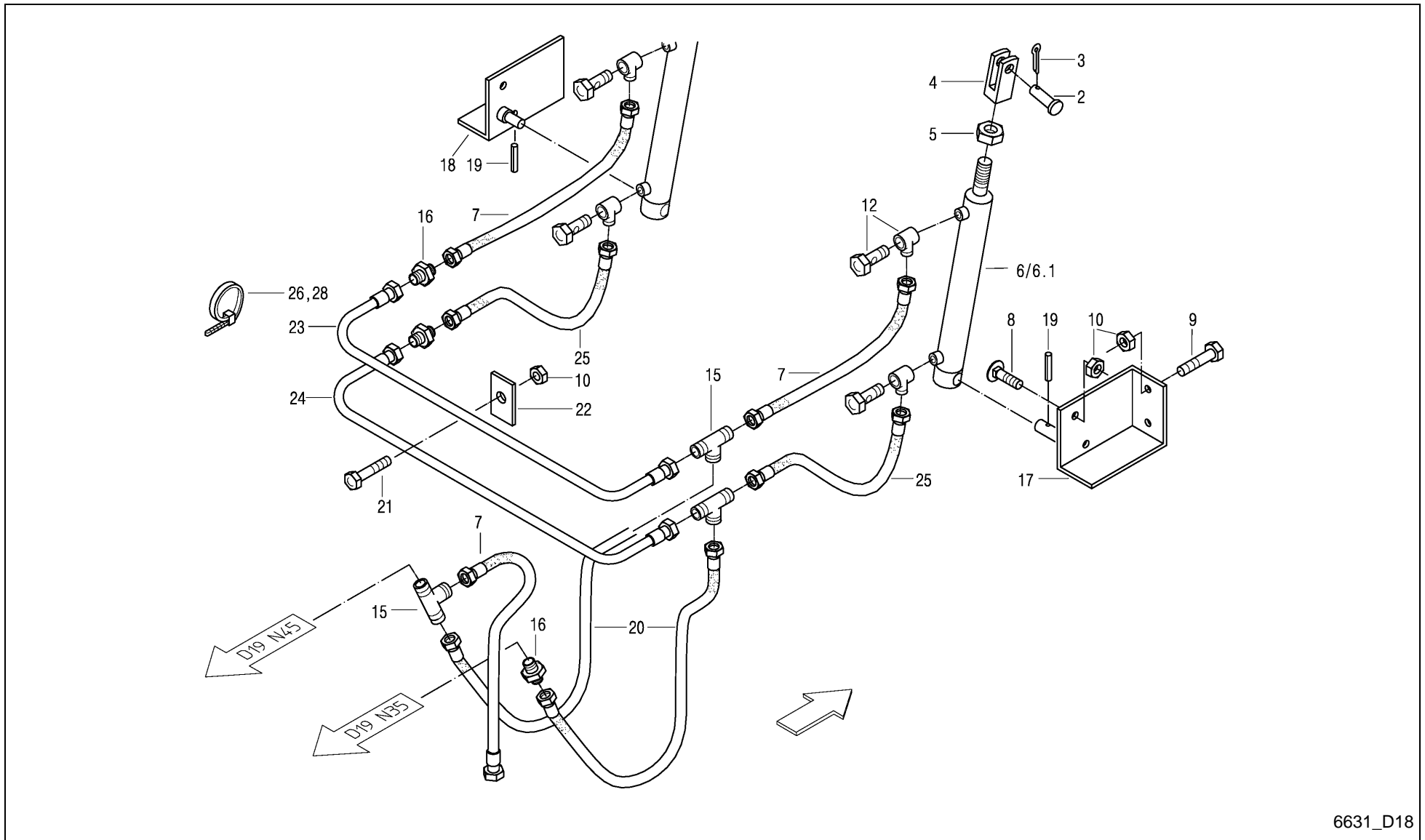

6631_D18

FeedMaster 3600T / HYDR. FOR DRY FORAGE SUPERST.



PosNo.	Part No.	Qty.	Description	Remark
1	VF01116622		CUTTING RING D08L DIN 3861-ST	
2	VF06210014	2	PIN	
3	VF01106447	2	SPLIT PIN	
4	VF06578611	2	CLEVIS	
5	VF01131116	2	HEX.NUT	
6	VF06577987	2	LIFT CYLINDER	
6	VF16512812	1	SEALING SET	
7	VF16613246	3	HYDR. HOSE 6X670	S D21
8	VF01141006	4	TRUSS-HEAD SCR. M8X16 109 GALV.	
9	VF01112322	4	HEX. HEAD SCREW	
10	VF01104944	11	NY LOCK NUT 8A3CD985	
12	VF16631123	4	UNION 2 PIECE	
14	VF01127346		UNION NUT H3105-CL 8-ST A3C	
15	VF01116740	3	NOZZLE XT 8-L GALV.	
16	VF01116705	3	CONNECTING SLEEVE XG 8-L CF	
17	VF06578608	1	BRACKET/CONSOLE	
18	VF06578609	1	BRACKET/CONSOLE	
19	VF01157344	2	DOWEL PIN	
20	VF16610781	2	HYDR.HOSE	
21	VF01100233	3	HEX.BOLT	
22	VF06555222	3	CONNECTING PLATE	
23	VF06578650	1	HYDR.PIPE	
24	VF06578651	1	HYDR.PIPE	
25	VF06576507	2	HYDR.HOSE	
26	VF06216480	2	CABLE TIE 368X4,8 SW SNX 3-100	
28	VF06216479	9	CABLE TIE 150X3,6 SW SNX 2-35	

FeedMaster 3600T / HYDR. FOR DRY FORAGE SUPERST.

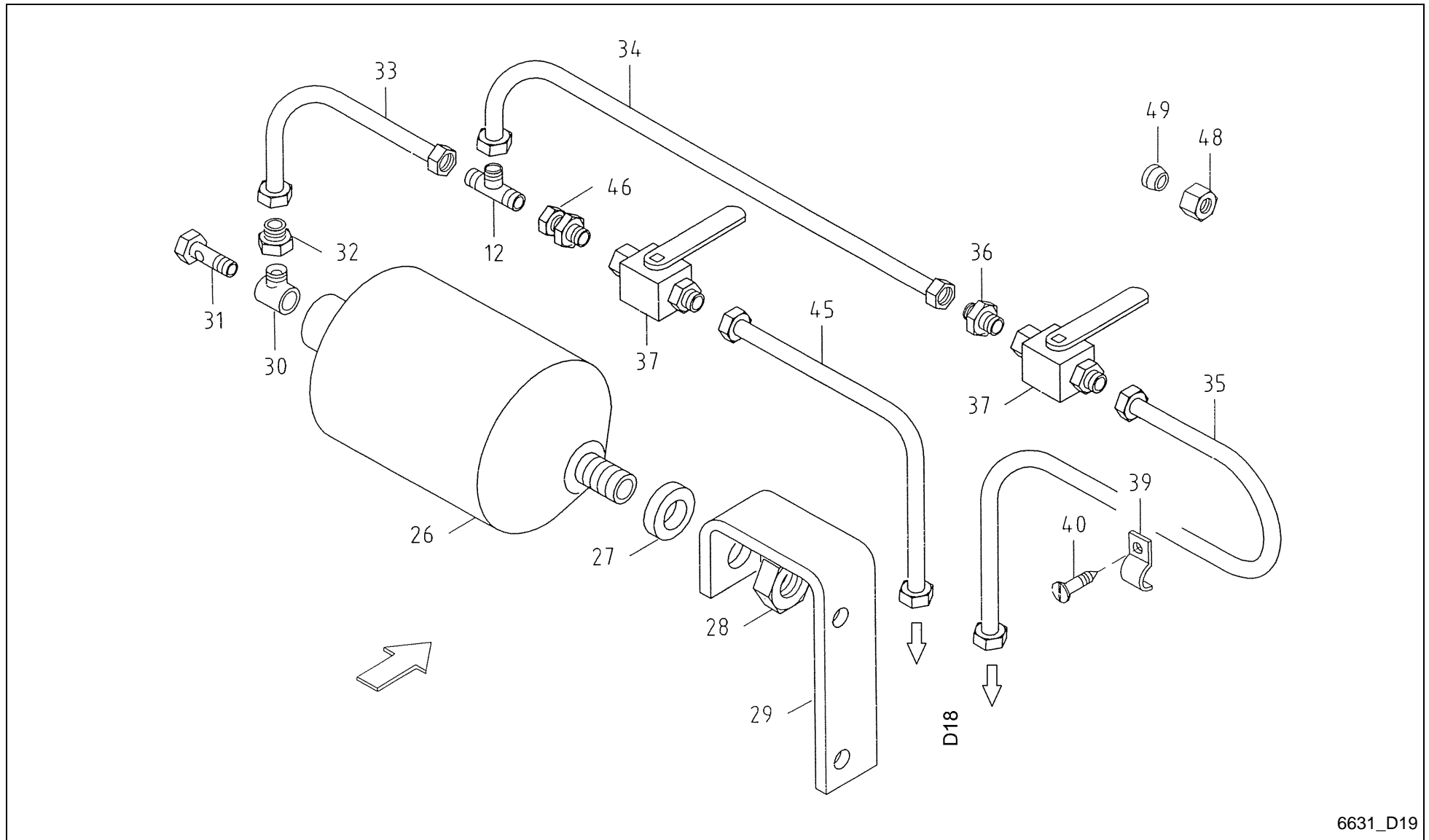

6631_D19

FeedMaster 3600T / HYDR. FOR DRY FORAGE SUPERST.



PosNo.	Part No.	Qty.	Description	Remark
12	VF01116740	1	NOZZLE XT 8-L GALV.	
26	VF06584800	1	HYDR.ACCUMULATOR	
27	VF06578645	1	RING	
28	VF06209580	1	NUT, HEX	
29	VF16611420	1	RETAINER	
30	VF01167953	1	UNION	
31	VF01167956	1	HOLLOW BOLT	
32	VF01173639	1	REDUCER INSERT	
33	VF16614901	1	HYDR.PIPE	
34	VF16613495	1	HYDR. PIPE	
35	VF16611423	1	HYDR. PIPE	
36	VF01141838	1	SCR.-IN FITTING XGE08LR GALV.	
37	VF01141391	2	VALVE ASSY, SHUT-OFF	
39	VF06216397	1	FIXING CLIP	
40	VF16631049	1	DRILLING SCREW 6.3X19 D7504	
45	VF16613497	1	HYDR. PIPE	
46	VF06217046	1	SCREW-IN FITTING EVGE08LR-ED A3C	
48	VF01127346		UNION NUT H3105-CL 8-ST A3C	
49	VF01116622		CUTTING RING D08L DIN 3861-ST	

FeedMaster 3600T / HYDR. FOR CRANKED DRAWBAR

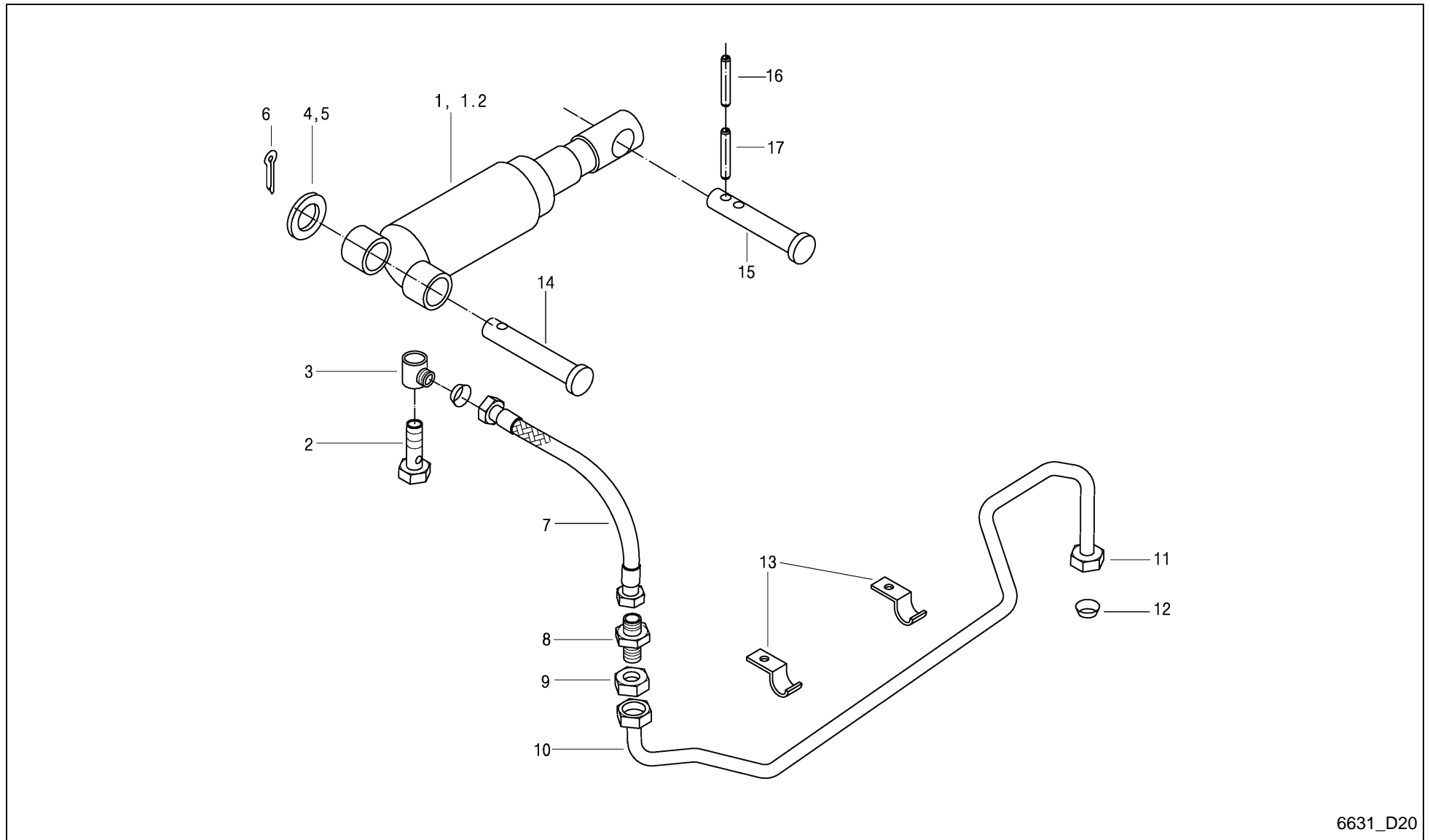

6631_D20

FeedMaster 3600T / HYDR. FOR CRANKED DRAWBAR



PosNo.	Part No.	Qty.	Description	Remark
1	VF16517146	1	HYDRAULIC CYLINDER	
1.1	VF16511004		SEALING SET	X 1
1.2	VF16630158	1	HYDRAULIC CYLINDER	H.u.P.Dippoldiswald
1.3	VF16630159	1	SEALING SET	X 1.2
2	VF01141296	1	HOLLOW BOLT	
3	VF01141295	1	UNION	
4	VF06214237	1	WASHER	
5	VF06214238	1	WASHER 34X50X5 A2C DIN 1441	
6	VF01106500	1	SPLIT PIN 8X50DIN94 GALV.	
7	VF01142641	1	HYDR. HOSE 0BODN6X 800 DKOL-8L+DKOL-8L	
8	VF01123941	1	STRAIGHT CONNECTOR XSV 8-L CF	
9	VF01121824	1	NUT M14X1,5 GM08L CF	
10	VF16517197	1	HYDR.PIPE	S D21
11	VF01127346		UNION NUT H3105-CL 8-ST A3C	
12	VF01116622		CUTTING RING D08L DIN 3861-ST	
13	VF06216397	2	FIXING CLIP	
14	VF01397555	1	PIN/BOLT/STUD	
15	VF16515159	1	PIN/BOLT/STUD	S F09
16	VF01136930	1	DOWEL PIN	
17	VF01157345	1	DOWEL PIN	

FeedMaster 3600T / HYDR. STEERING

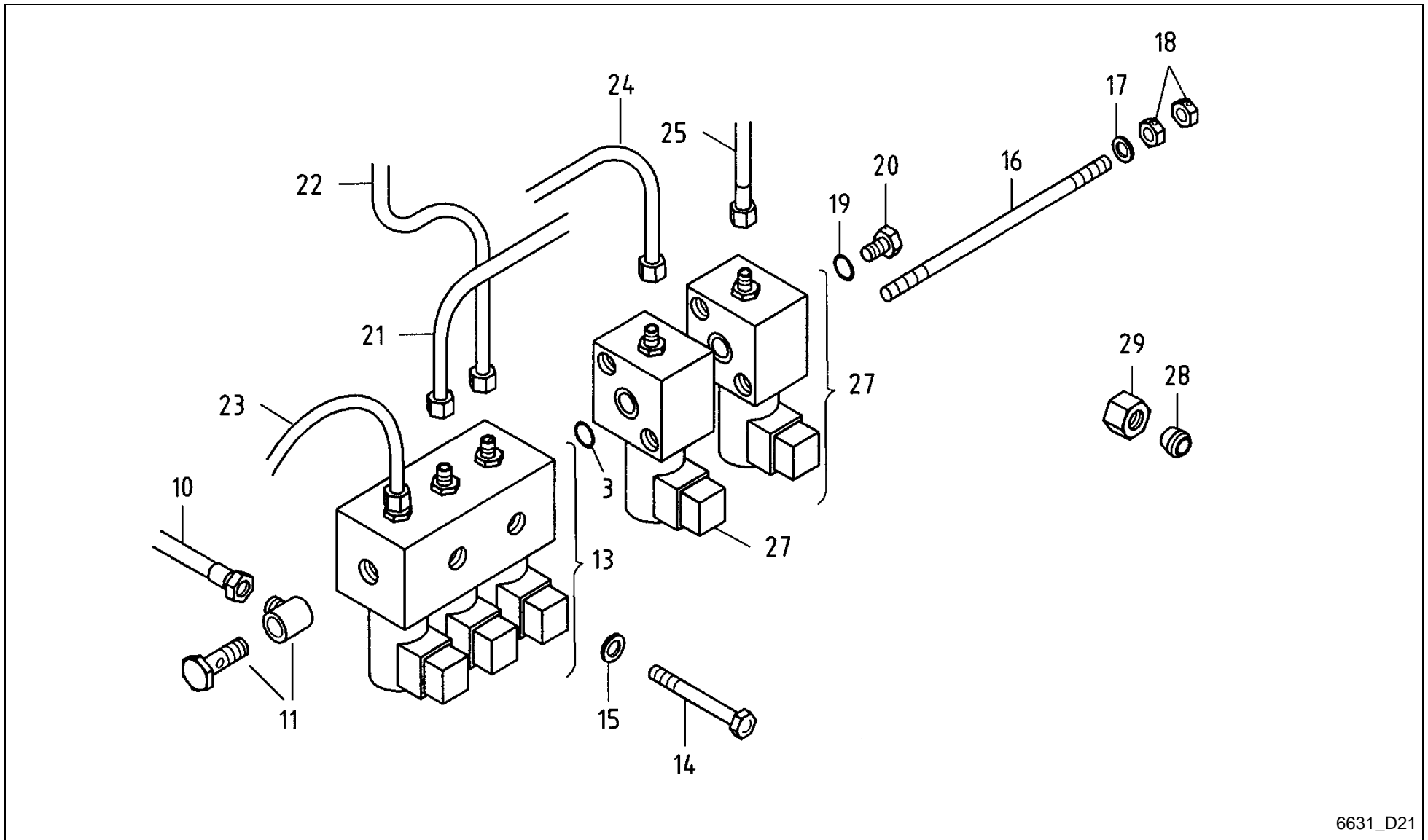

6631_D21

FeedMaster 3600T / HYDR. STEERING



PosNo.	Part No.	Qty.	Description	Remark
3	VF01169581	1	O-RING	
10	VF16613449	1	HYDR.PIPE	S D15
11	VF16631123	1	UNION 2 PIECE	
13	VF16516558	1	VALVE BLOCK	
14	VF01111168	2	HEX. HEAD SCREW	
15	VF01107163	2	WASHER	
16	VF16610913	2	THREADED PIN	
17	VF01143103	2	WASHER/DISC/PLATE	
18	VF01112824	4	HEX. NUT	
19	VF01118675	1	SEAL RING	
20	VF01143104	1	SCREW PLUG	
21	VF16613313	1	HYDR.PIPE	S D16
22	VF16517193	1	HYDR.PIPE	S D22
23	VF16517194	1	HYDR.PIPE	S D17
24	VF16517197	1	HYDR.PIPE	S D20
25	VF16613246	1	HYDR. HOSE 6X670	S D18
27	VF16631291	2	VALVE BLOCK WITH MANUAL EMERGENCY	
28	VF01116622		CUTTING RING D08L DIN 3861-ST	
29	VF01127346		UNION NUT H3105-CL 8-ST A3C	

FeedMaster 3600T / HYDRAULIC FOR CONVEYOR

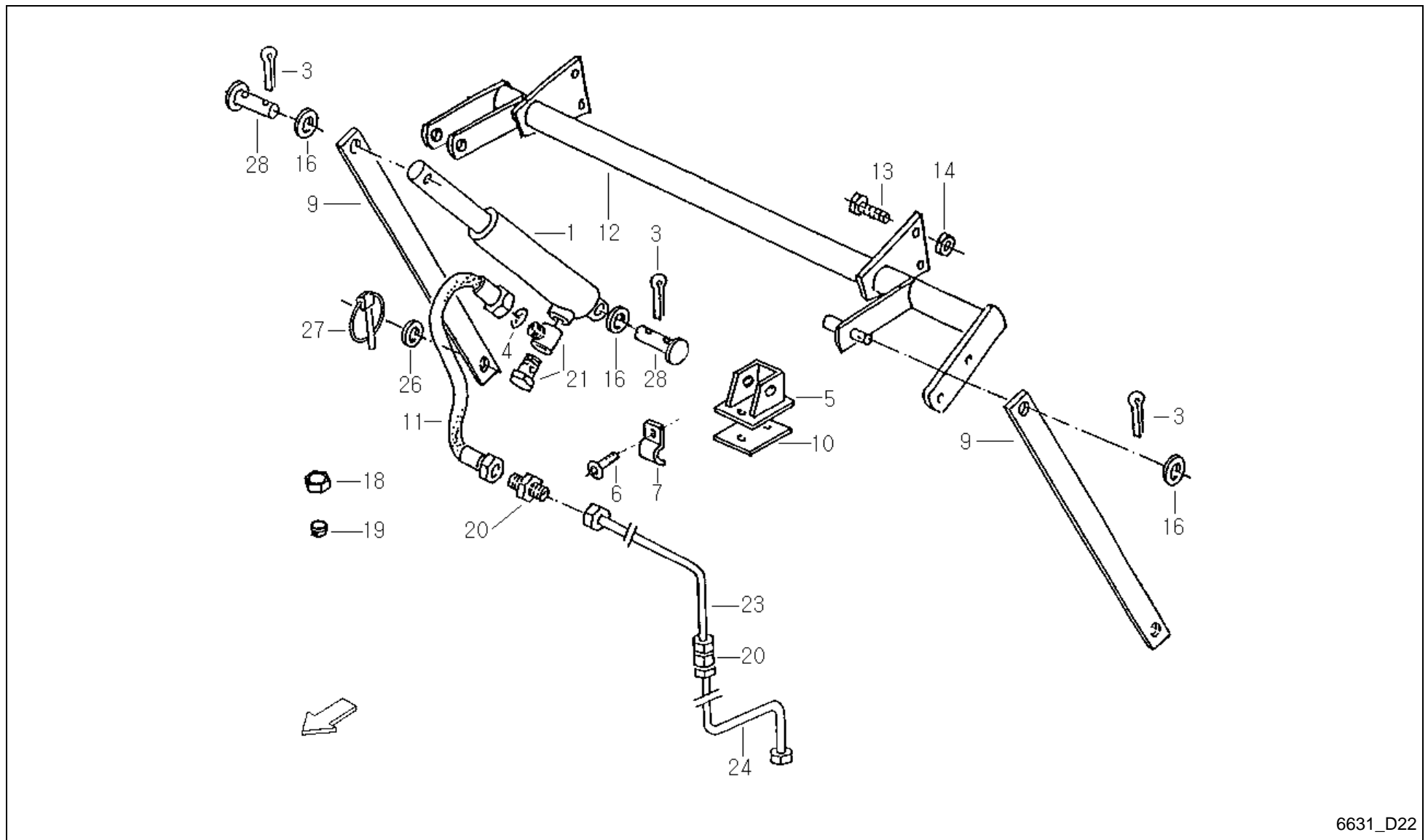

6631_D22

FeedMaster 3600T / HYDRAULIC FOR CONVEYOR



PosNo.	Part No.	Qty.	Description	Remark
1	VF06587590	1	HYDR.CYLINDER	
1.1	VF06286217		SEALING SET	
3	VF01106451	3	SPLIT PIN	
4	VF06581181	1	RESTRICTOR 1,0 MM D8,0X1	
5	VF06571018	1	BRACKET	
6	VF16631049	3	DRILLING SCREW 6.3X19 D7504	+A 2006
7	VF06216397	3	FIXING CLIP	
9	VF06577584	2	PULL ROD	
10	VF06578830	1	SHIM	
11	VF06571331	1	HYDR. HOSE 0BODN6X 600 DKOL-8L+DKOL-8L	
12	VF06577469	1	TUBE	
13	VF01103341	4	HEX.HEAD SCREW	
14	VF06209778	4	LOCK NUT	
16	VF06214217	3	WASHER 17X28X3DIN1441 GALV.	
18	VF01127346		UNION NUT H3105-CL 8-ST A3C	
19	VF01116622		CUTTING RING D08L DIN 3861-ST	
20	VF01116705	2	CONNECTING SLEEVE XG 8-L CF	
21	VF16631123	1	UNION 2 PIECE	
23	VF06579491	1	HYDR.PIPE	
24	VF16517193	1	HYDR.PIPE	S D21
26	VF06214226	2	WASHER	
27	VF01126332	2	DOWEL PIN	
28	VF01139468	2	PIN	

FeedMaster 3600T / LUBE SYSTEM

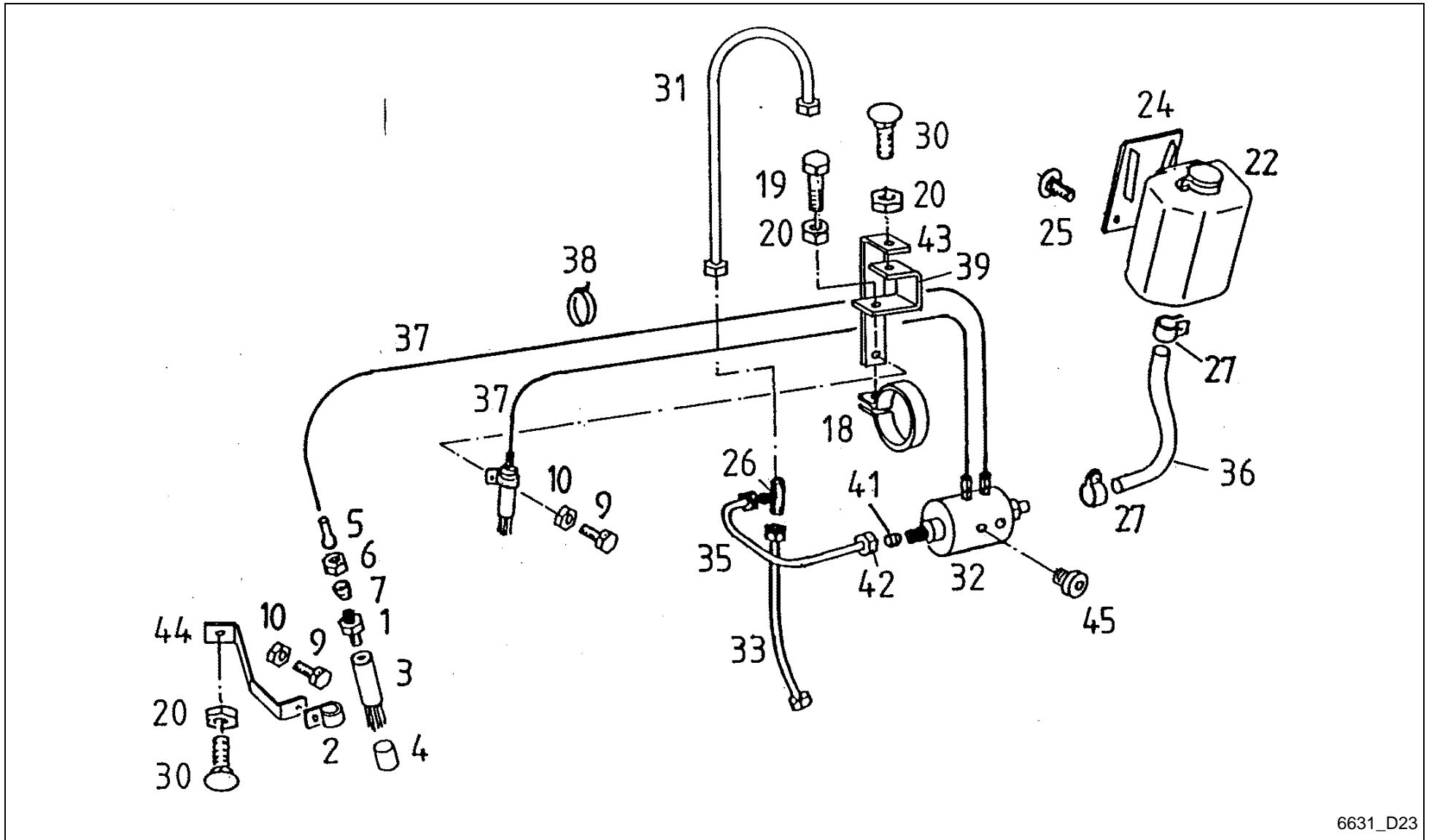

6631_D23

FeedMaster 3600T / LUBE SYSTEM



PosNo.	Part No.	Qty.	Description	Remark
1	VF06216815	2	NIPPLE	
2	VF01211882	2	PIPE CLIP RSGU1 15X15	
3	VF06551690	2	BRUSH	
4	VF01141235	2	INSULATING HOSE	
5	VF01177316	4	STIFFENING SLEEVE	
6	VF06216773	4	CAP NUT	
7	VF01103117	4	CUTTING RING	
9	VF01103316	2	HEX. HEAD SCREW	
10	VF01114357	2	LOCK NUT	
18	VF01143083	1	PIPE CLIP, 48,55 DIN 71555 RS	
19	VF01112341	1	HEX. HEAD SCREW	
20	VF01104944	3	NY LOCK NUT 8A3CD985	
22	VF06551694	1	TANK	
24	VF06575213	1	RETAINER	
25	VF01397598	2	SELF-TAPPING SCREW	
26	VF01116740	1	NOZZLE XT 8-L GALV.	
27	VF01128266	2	HOSE CLIP	
30	VF01142565	2	TRUSS-HEAD SCR. M8X20 109 GALV.	
31	VF16515591	1	HYDR.PIPE	
32	VF16611359	1	OIL PUMP	
33	VF16515593	1	HYDR.PIPE	
35	VF16611240	1	HYDR.PIPE	
36	VF16611242	1	HOSE	
37	VF06554451	2	PIPE	
38	VF06216479	6	CABLE TIE 150X3,6 SW SNX 2-35	
39	VF16611241	1	RETAINER	
41	VF01116622		CUTTING RING D08L DIN 3861-ST	
42	VF01127346		UNION NUT H3105-CL 8-ST A3C	
43	VF06575216	1	ANGLE PLATE	
44	VF06575217	1	RETAINER	
45	VF16611248	6	BLANK PLUG	

FeedMaster 3600T / LUBE SYSTEM DRUM WITH 4 RAKES

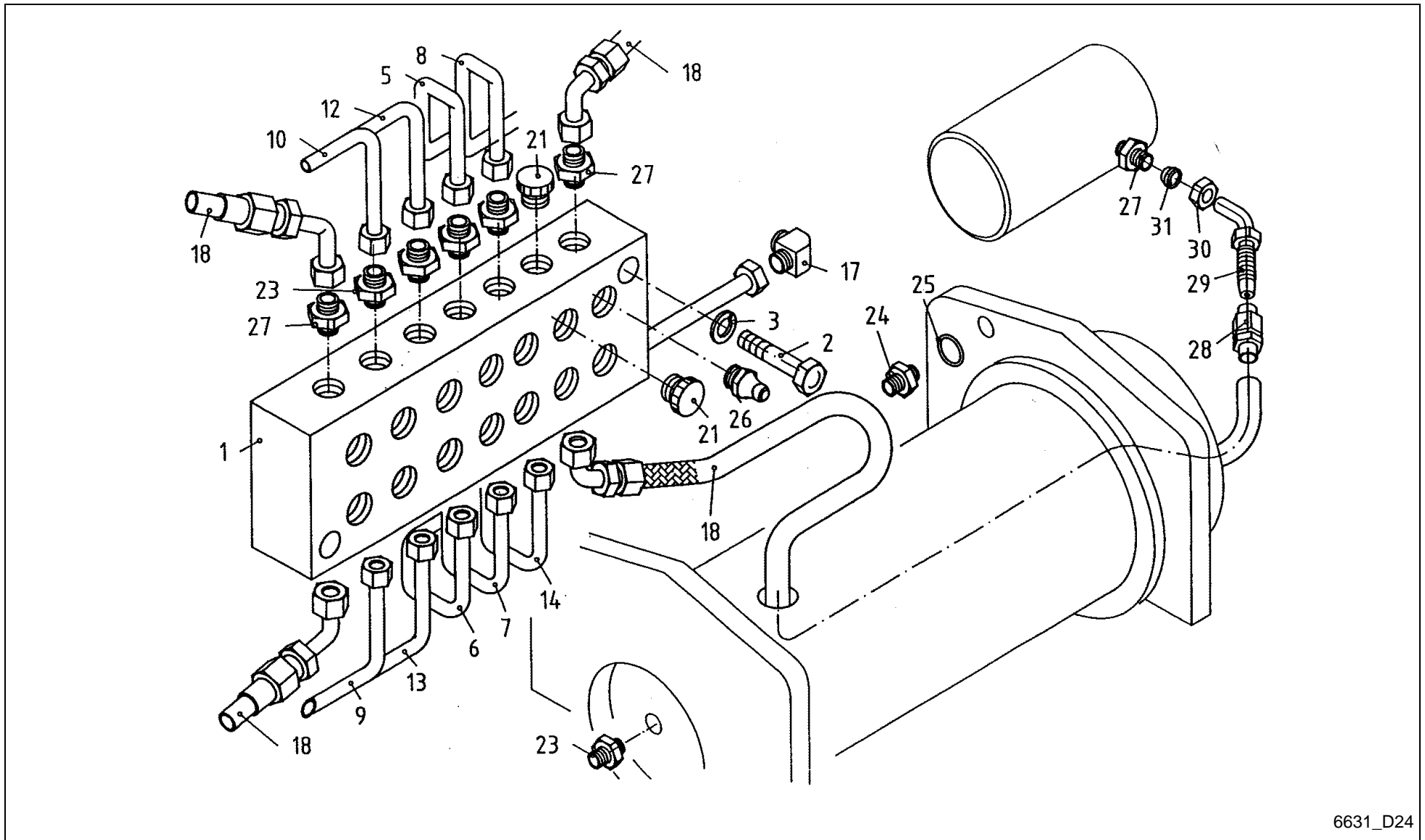

6631_D24

FeedMaster 3600T / LUBE SYSTEM DRUM WITH 4 RAKES



PosNo.	Part No.	Qty.	Description	Remark
1	VF16516677	1	STRIP	
2	VF01122389	2	HEX.HEAD SCREW	
3	VF01102797	2	SPRING WASHER	
5	VF16516696	1	LUBE TUBE	RECHENLAGER
6	VF16516699	1	LUBE TUBE	RECHENLAGER
7	VF16516700	1	LUBE TUBE	RECHENLAGER
8	VF16516701	1	LUBE TUBE	RECHENLAGER
9	VF16516702	1	LUBE TUBE	FLANSCHZAPFEN
10	VF16516705	1	LUBE TUBE	FLANSCHZAPFEN
12	VF16516706	1	LUBE TUBE	FLANSCHZAPFEN
13	VF16516707	1	LUBE TUBE	FLANSCHZAPFEN
14	VF16516708	1	LUBE TUBE	TROMMELLAGER
17	VF06216854	1	ANGULAR UNION	
18	VF16610926	4	LUBE HOSE	
21	VF06216527	2	PROTECTING PLUG	
23	VF06216815	14	NIPPLE	
24	VF01397760	4	SOCKET/ADAPTER	
25	VF01163589	4	O-RING	
26	VF01120693	13	GREASE FITTING H1 AM 8X1 DIN 71412	
27	VF01397933	8	SOCKET/ADAPTER	
28	VF16516717	4	SCREW SLEEVE	
29	VF16518135	4	PIPE SOCKET	
30	VF01100982	4	UNION NUT	
31	VF01292484	4	SEALING	

FeedMaster 3600T / LUBE SYSTEM DRUM WITH 6 RAKES

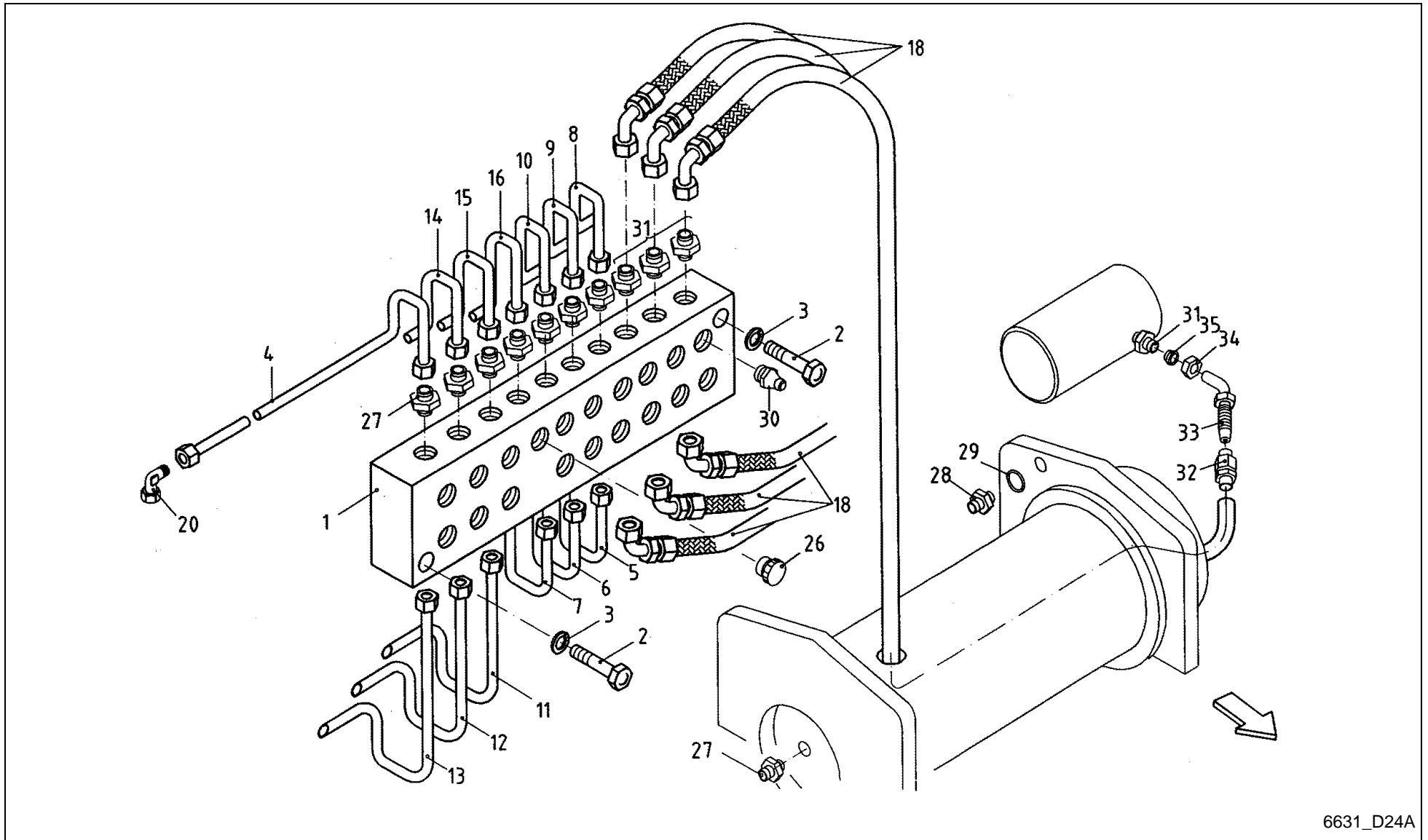

6631_D24A

FeedMaster 3600T / LUBE SYSTEM DRUM WITH 6 RAKES



PosNo.	Part No.	Qty.	Description	Remark
1	VF16630171	1	RAIL	
2	VF01122389	2	HEX.HEAD SCREW	
3	VF01102797	2	SPRING WASHER	
4	VF16630172	1	LUBRICATION TUBE 1	
5	VF16630174	1	LUBRICATION TUBE 2	
6	VF16630176	1	LUBRICATION TUBE 3	
7	VF16630178	1	LUBRICATION TUBE 4	
8	VF16630180	1	LUBRICATION TUBE 5	
9	VF16630182	1	LUBRICATION TUBE 6	
10	VF16630184	1	LUBRICATION TUBE 7	
11	VF16630186	1	LUBRICATION TUBE 8	
12	VF16630188	1	LUBRICATION TUBE 9	
13	VF16630190	1	LUBRICATION TUBE 10	
14	VF16630192	1	LUBRICATION TUBE 11	
15	VF16630194	1	LUBRICATION TUBE 12	
16	VF16630196	1	LUBRICATION TUBE 13	
18	VF16630200	6	LUBRICATION HOSE 2	
20	VF06216854	1	ANGULAR UNION	
26	VF06216527		PROTECTING PLUG	
27	VF06216815	19	NIPPLE	
28	VF01397760	6	SOCKET/ADAPTER	
29	VF01163589	6	O-RING	
30	VF01120693	19	GREASE FITTING H1 AM 8X1 DIN 71412	
31	VF01397933	12	SOCKET/ADAPTER	
32	VF16516717	6	SCREW SLEEVE	
33	VF16518135	6	PIPE SOCKET	
34	VF01100982	6	UNION NUT	
35	VF01292484	6	SEALING	

FeedMaster 3600T / LUBE SYSTEM DRUM WITH 5 RAKES

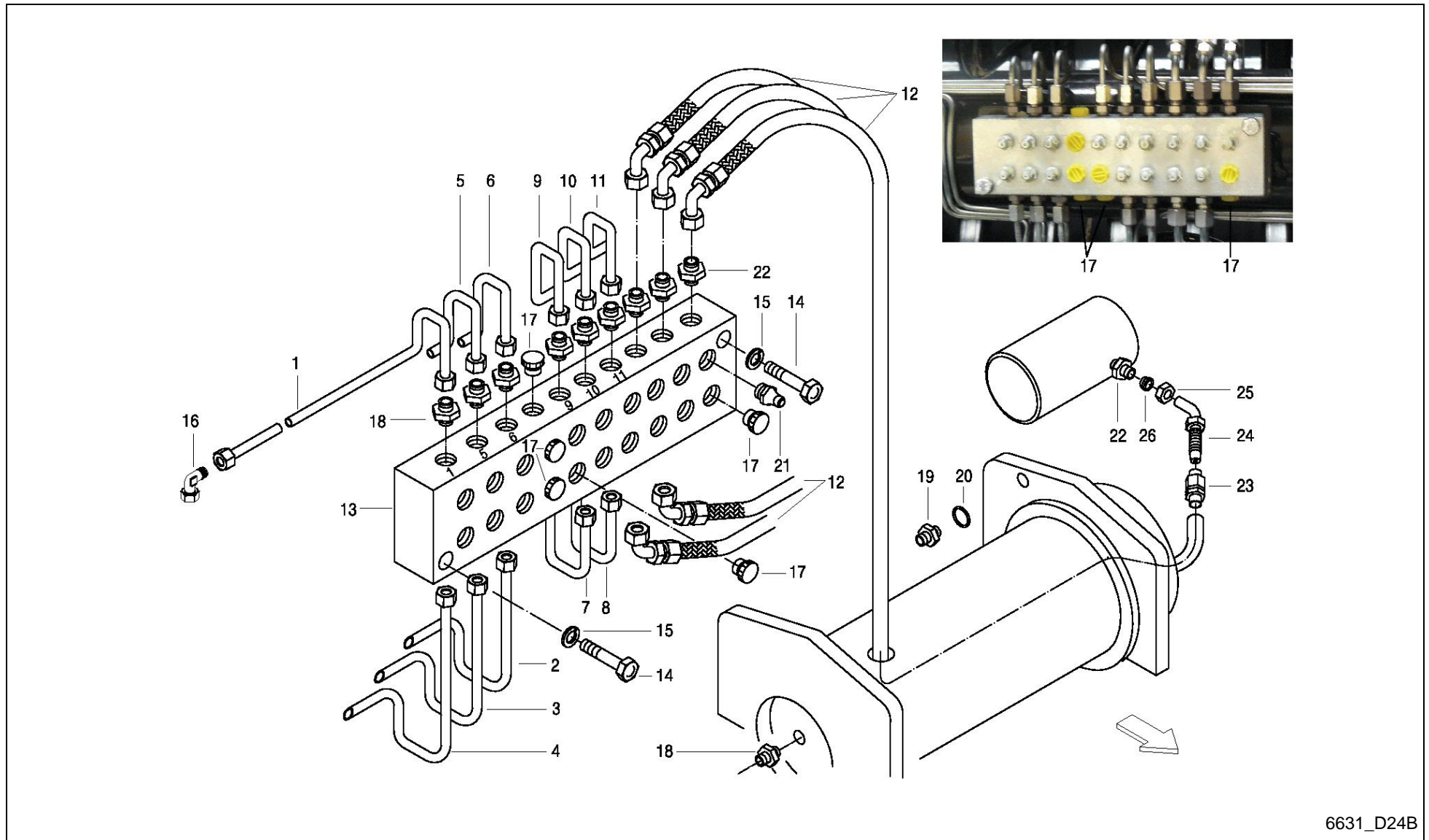

6631_D24B

FeedMaster 3600T / LUBE SYSTEM DRUM WITH 5 RAKES



PosNo.	Part No.	Qty.	Description	Remark
1	A143012000	1	LUBRICATION TUBE 1	
2	A143012100	1	LUBRICATION TUBE 2	
3	A143012200	1	LUBRICATION TUBE 3	
4	A143012300	1	LUBRICATION TUBE 4	
5	A143012400	1	LUBRICATION TUBE 5	
6	A143012500	1	LUBRICATION TUBE 6	
7	A143012600	1	LUBRICATION TUBE 7	
8	A143012700	1	LUBRICATION TUBE 8	
9	A143012800	1	LUBRICATION TUBE 9	
10	A143012900	1	LUBRICATION TUBE 10	
11	A143013000	1	LUBRICATION TUBE 11	
12	A143013100	5	LUBRICATION HOSE	
13	VF16630171	1	RAIL	
14	VF01122389	2	HEX.HEAD SCREW	
15	VF01102797	2	SPRING WASHER	
16	VF06216854	1	ANGULAR UNION	
17	VF06216527	8	PROTECTING PLUG	
18	VF06216815	19	NIPPLE	
19	VF01397760	6	SOCKET/ADAPTER	
20	VF01163589	6	O-RING	
21	VF01120693	19	GREASE FITTING H1 AM 8X1 DIN 71412	
22	VF01397933	12	SOCKET/ADAPTER	
23	VF16516717	5	SCREW SLEEVE	
24	VF16518135	5	PIPE SOCKET	
25	VF01100982	5	UNION NUT	
26	VF01292484	5	SEALING	

FeedMaster 3600T / GREEN FODDER SUPERSTRUCTURE SUPPORTS

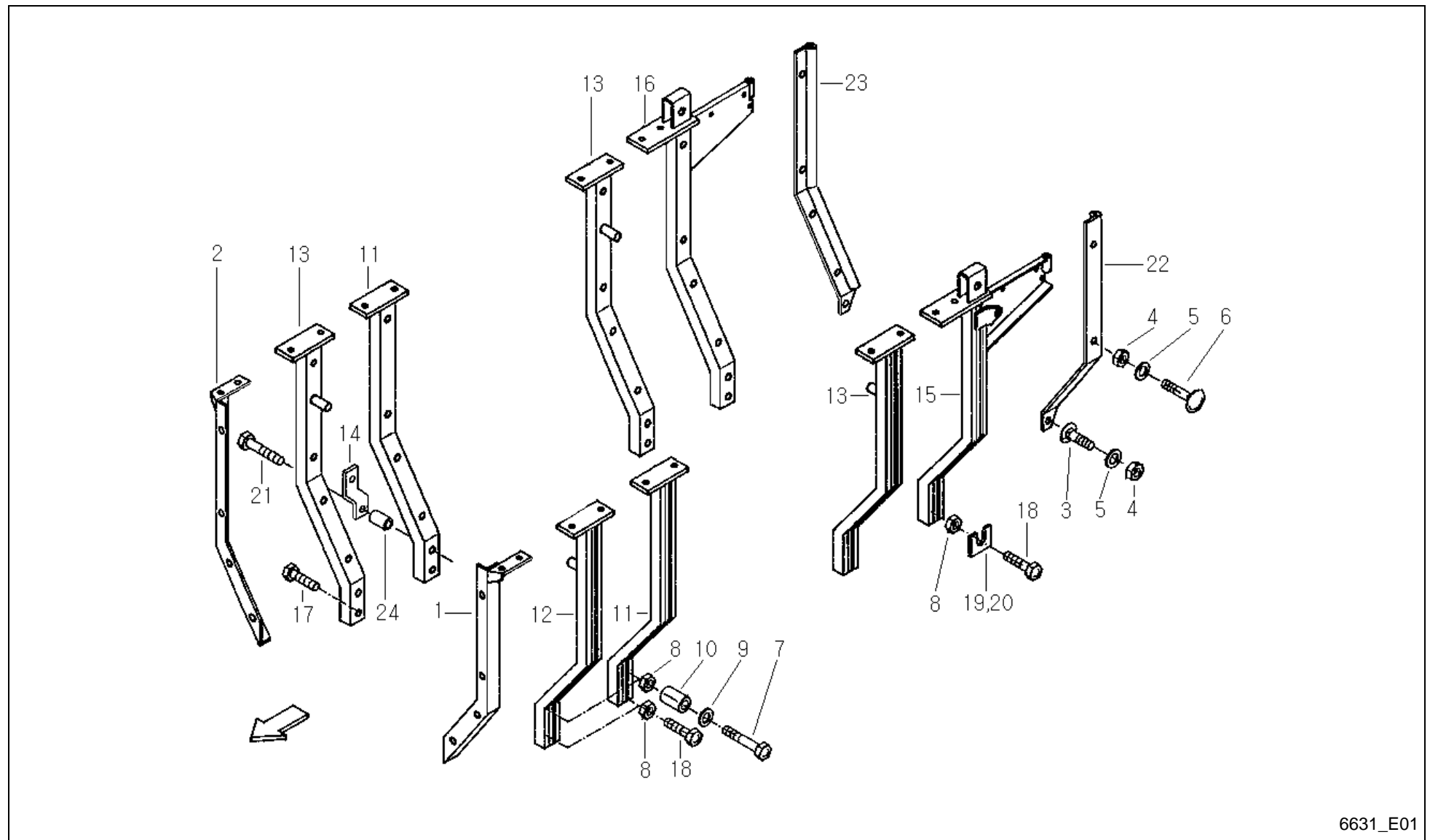

6631_E01

FeedMaster 3600T / GREEN FODDER SUPERSTRUCTURE SUPPORTS



PosNo.	Part No.	Qty.	Description	Remark
1	VF06577238	1	ECKPROFIL LI. GSW .	
2	VF06577240	1	ECKPROFIL RE. GSW.	
3	VF06207534	2	SCREW	
4	VF01104944	20	NY LOCK NUT 8A3CD985	
5	VF06214192	20	WASHER 8,4X25X3 GALV.	
6	VF06207535	14	OVAL HEADED BOLT	
7	VF06209249	4	SCREW M12X80 D931 10.9 A3CDIN267-27 COAT	
8	VF06209778	26	LOCK NUT	
9	VF06214207	4	WASHER	
10	VF06581494	4	SPACER TUBE	
11	VF06577097	6	SUPPORT	
12	VF06577242	1	SUPPORT	
13	VF06577095	3	SUPPORT	
14	VF16511577	6	CONNECTING PLATE	
15	VF16515902	1	SUPPORT	
16	VF16515904	1	SUPPORT	
17	VF06277504	1	HEX. HEAD SCREW	
18	VF01102701	19	HEX HEAD SCREW	
19	VF06577562	2	SHIM	
20	VF06577563	2	SHIM	
21	VF01139722	6	HEX.BOLT	
22	VF16515926	1	CROSS BAR	
23	VF16515927	1	CROSS BAR	
24	VF16613377	1	SPACING TUBE	

FeedMaster 3600T / GREEN FODDER SUPERSTRUCTURE - SIDE PANELS (-A 2013)

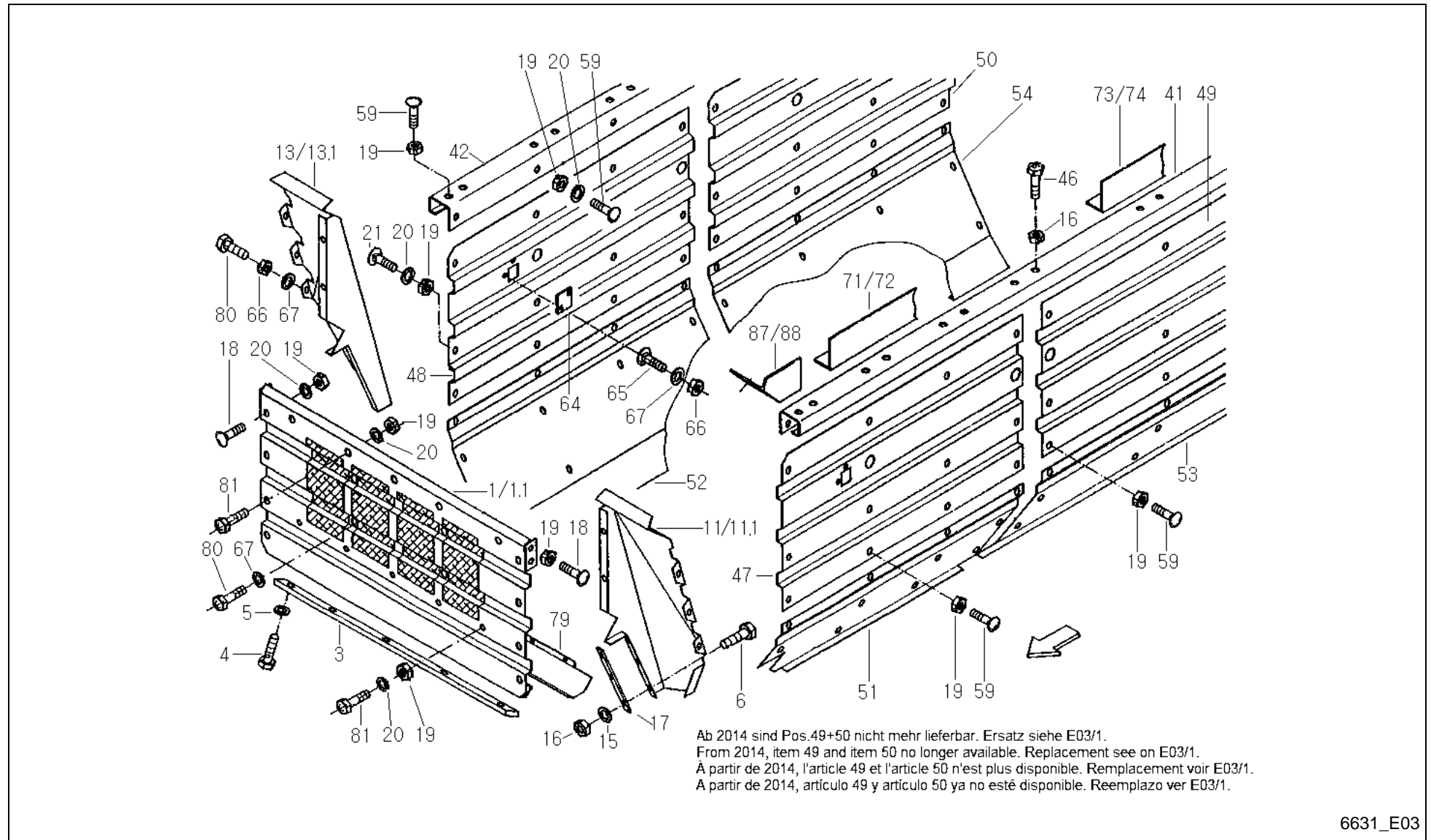

6631_E03

FeedMaster 3600T / GREEN FODDER SUPERSTRUCTURE - SIDE PANELS (-A 2013)



PosNo.	Part No.	Qty.	Description	Remark
1	VF16516404	1	FRONT WALL	-A 2005
1.1	VF16631340	1	FRONT WALL	+A 2006
3	VF16515928	1	STRIP	
4	VF01111298	7	HEX. HEAD SCREW	
5	VF01127538	4	WASHER	
6	VF01112429	4	HEX. HEAD SCREW	
11	VF16516319	1	CORNER SHEET	-A 2005
11.1	VF16631346	1	DECKBLECH LI	+A 2006
13	VF16516320	1	CORNER SHEET	-A 2005
13.1	VF16631347	1	DECKBLECH RE.	+A 2006
15	VF06214197	4	WASHER 10,5X30X3 GALV.	
16	VF06209768	28	LOCK NUT	
17	VF16516399	1	STRIP	-A 2005
18	VF06207534	20	SCREW	
19	VF01104944	110	NY LOCK NUT 8A3CD985	
20	VF06214192	47	WASHER 8,4X25X3 GALV.	
21	VF06207535	8	OVAL HEADED BOLT	
41	VF16515918	1	CROSS BAR	
42	VF16515920	1	CROSS BAR	
45	VF01112333		HEX. HEAD SCREW	
46	VF01112418	24	BOLT, SCREW	
47	A143032180	1	SIDE PANEL LEFT	
48	A143032280	1	SIDE PANEL RIGHT	
49	VF16515915	1	SIDE WALL	
50	VF16515917	1	SIDE WALL	
51	A143032780	1	SIDE PANEL LEFT	
52	A143032880	1	SIDE PANEL RIGHT	
53	A143032980	1	SIDE PANEL LEFT	
54	A143033080	1	SIDE PANEL RIGHT	
59	VF01142565	92	TRUSS-HEAD SCR. M8X20 109 GALV.	
64	VF06579237	2	PLATE	
65	VF01138989	4	TRUSS-HEAD SCREW	
66	VF01114357	18	LOCK NUT	
67	VF06214189	32	WASHER 6,4X18X2 A2C	
71	VF16611391	1	SHIELD IN FRONT RI.	
72	VF16611392	1	SHIELD IN FRONT LEFT	
73	VF16611394	1	SHIELD BACK RIGHT	
74	VF16611395	1	SHIELD BACK LEFT	
79	VF06572448	1	DEFL.SHEET	-A 2005
80	VF01103316	14	HEX. HEAD SCREW	

FeedMaster 3600T / GREEN FODDER SUPERSTRUCTURE - SIDE PANELS (-A 2013)

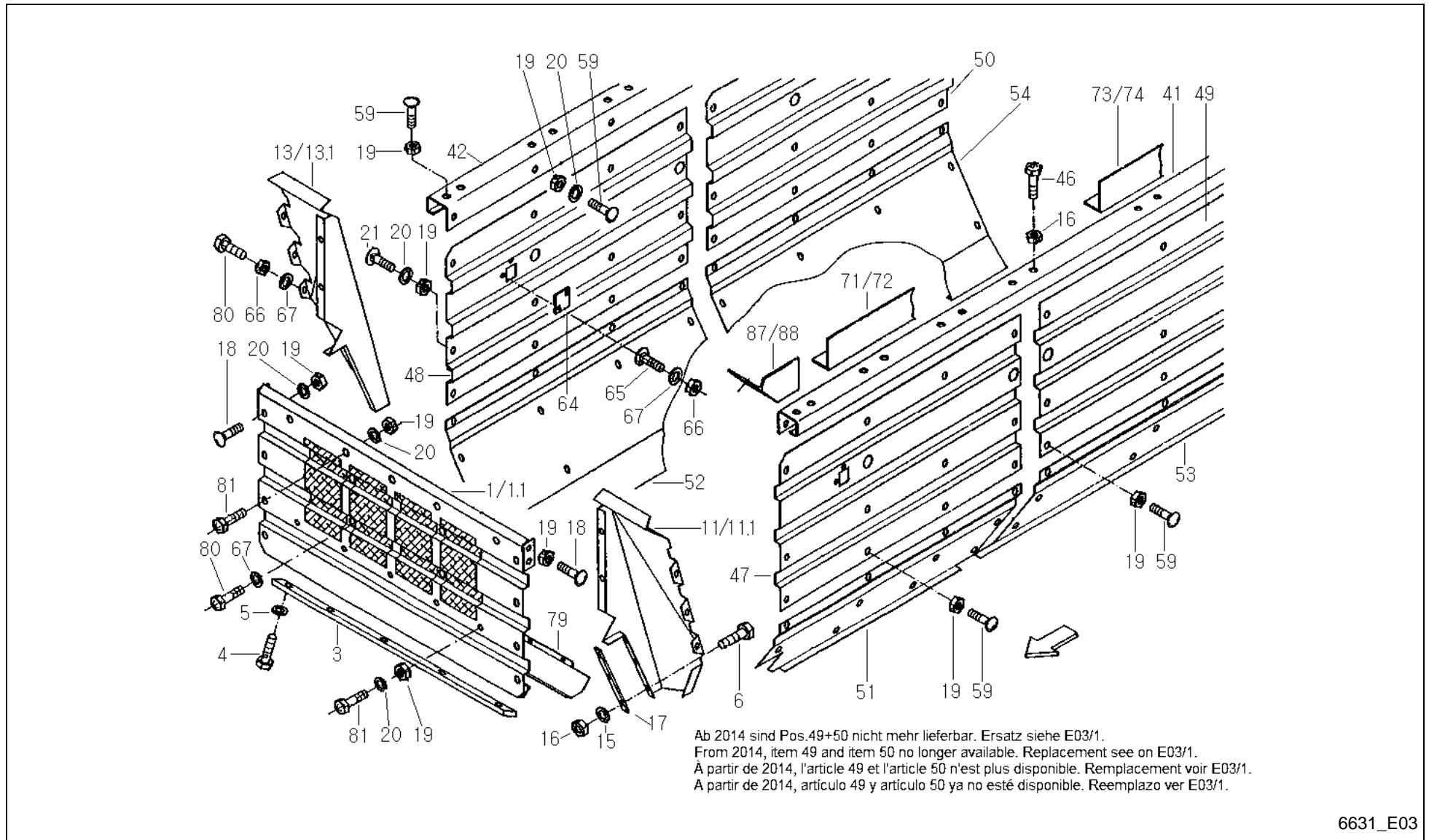

6631_E03

FeedMaster 3600T / GREEN FODDER SUPERSTRUCTURE - SIDE PANELS (-A 2013)



PosNo.	Part No.	Qty.	Description	Remark
81	VF01112341	3	HEX. HEAD SCREW	
86	VF01107163	4	WASHER	
87	VF16614908	1	ANGLE SHIELD RIGHT	
88	VF16614907	1	ANGLE SHIELD LEFT	

FeedMaster 3600T / GREEN FODDER SUPERSTRUCTURE - SIDE PANELS (+A 2014)

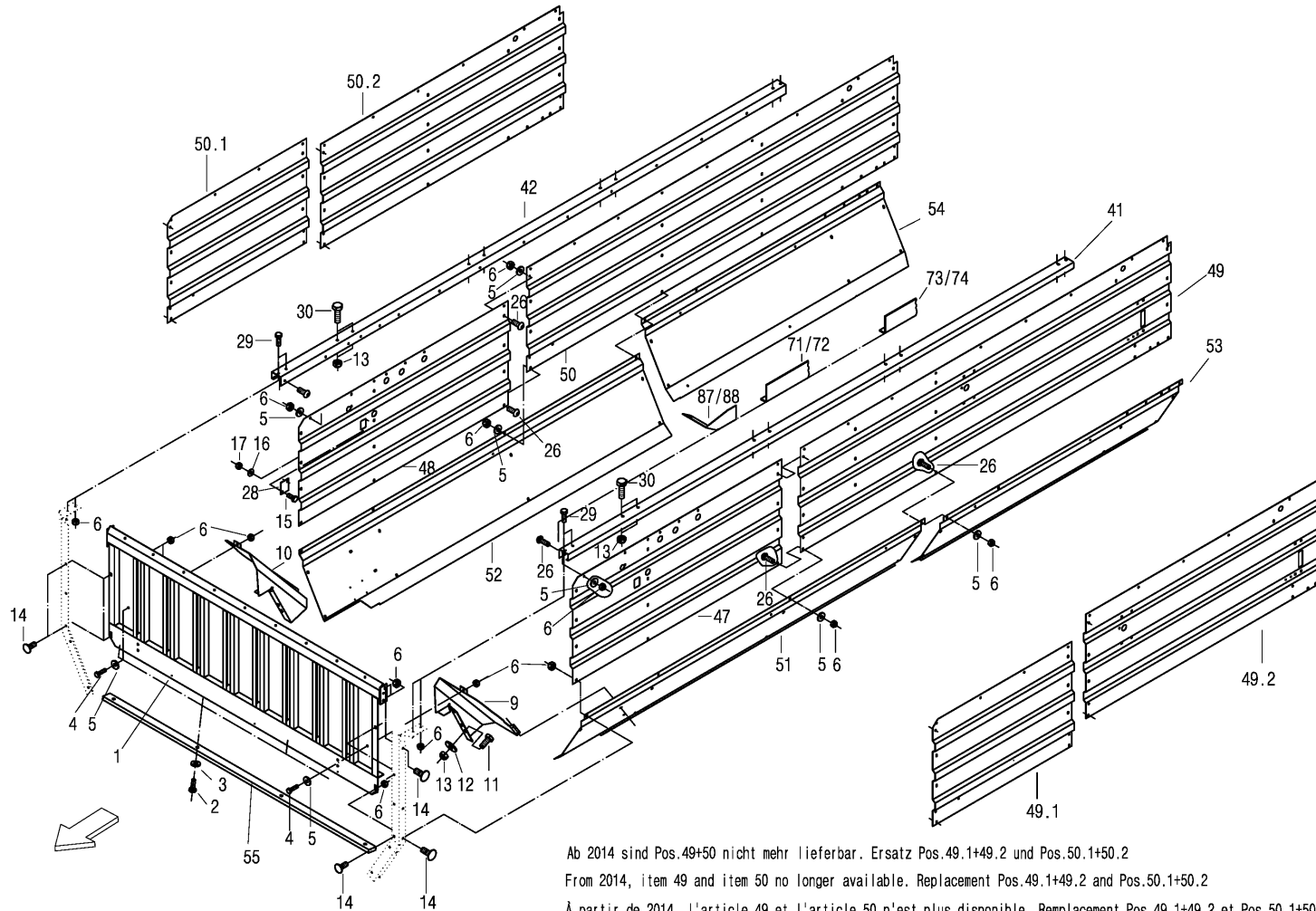

Ab 2014 sind Pos.49+50 nicht mehr lieferbar. Ersatz Pos.49.1+49.2 und Pos.50.1+50.2
 From 2014, item 49 and item 50 no longer available. Replacement Pos.49.1+49.2 and Pos.50.1+50.2
 À partir de 2014, l'article 49 et l'article 50 n'est plus disponible. Remplacement Pos.49.1+49.2 et Pos.50.1+50.2
 A partir de 2014, artículo 49 y artículo 50 ya no está disponible. Reemplazo Pos.49.1+49.2 y Pos.50.1+50.2

6631_E03_1

FeedMaster 3600T / GREEN FODDER SUPERSTRUCTURE - SIDE PANELS (+A 2014)



PosNo.	Part No.	Qty.	Description	Remark
1	VF16631340	1	FRONT WALL	
2	VF01112429	4	HEX. HEAD SCREW	
3	VF01127538	4	WASHER	
4	VF01112341	2	HEX. HEAD SCREW	
5	VF06214192	50	WASHER 8,4X25X3 GALV.	
6	VF01104944	120	NY LOCK NUT 8A3CD985	
9	VF16631346	1	DECKBLECH LI	
10	VF16631347	1	DECKBLECH RE.	
11	VF01112418	24	BOLT, SCREW	
12	VF06214197	8	WASHER 10,5X30X3 GALV.	
13	VF06209768	24	LOCK NUT	
14	VF06207534	14	SCREW	
15	VF01138989	4	TRUSS-HEAD SCREW	
16	VF06214189	4	WASHER 6,4X18X2 A2C	
17	VF01114357	4	LOCK NUT	
26	VF01142565	98	TRUSS-HEAD SCR. M8X20 109 GALV.	
28	VF06579237	2	PLATE	
29	VF01112333	4	HEX. HEAD SCREW	
30	VF01112429	16	HEX. HEAD SCREW	
41	VF16515918	1	CROSS BAR	
42	VF16515920	1	CROSS BAR	
47	A143032180	1	SIDE PANEL LEFT	
48	A143032280	1	SIDE PANEL RIGHT	
49	VF16515915	1	SIDE WALL	-A 2013
49.1	A143032380	1	SIDE PANEL LEFT UP MIDDLE	+A 2014
49.2	A143032480	1	SIDE PANEL LEFT UP REAR	+A 2014
50	VF16515917	1	SIDE WALL	-A 2013
50.1	A143032580	1	SIDE PANEL RIGHT UP MIDDLE	+A 2014
50.2	A143032680	1	SIDE PANEL RIGHT UP REAR	+A 2014
51	A143032780	1	SIDE PANEL LEFT	
52	A143032880	1	SIDE PANEL RIGHT	
53	A143032980	1	SIDE PANEL LEFT	
54	A143033080	1	SIDE PANEL RIGHT	
55	VF16515928	1	STRIP	
71	VF16611391	1	SHIELD IN FRONT RI.	
72	VF16611392	1	SHIELD IN FRONT LEFT	
73	VF16611394	1	SHIELD BACK RIGHT	
74	VF16611395	1	SHIELD BACK LEFT	
87	VF16614908	1	ANGLE SHIELD RIGHT	
88	VF16614907	1	ANGLE SHIELD LEFT	

FeedMaster 3600T / HYDR. ADJUSTMENT OF BACK NET UNIT

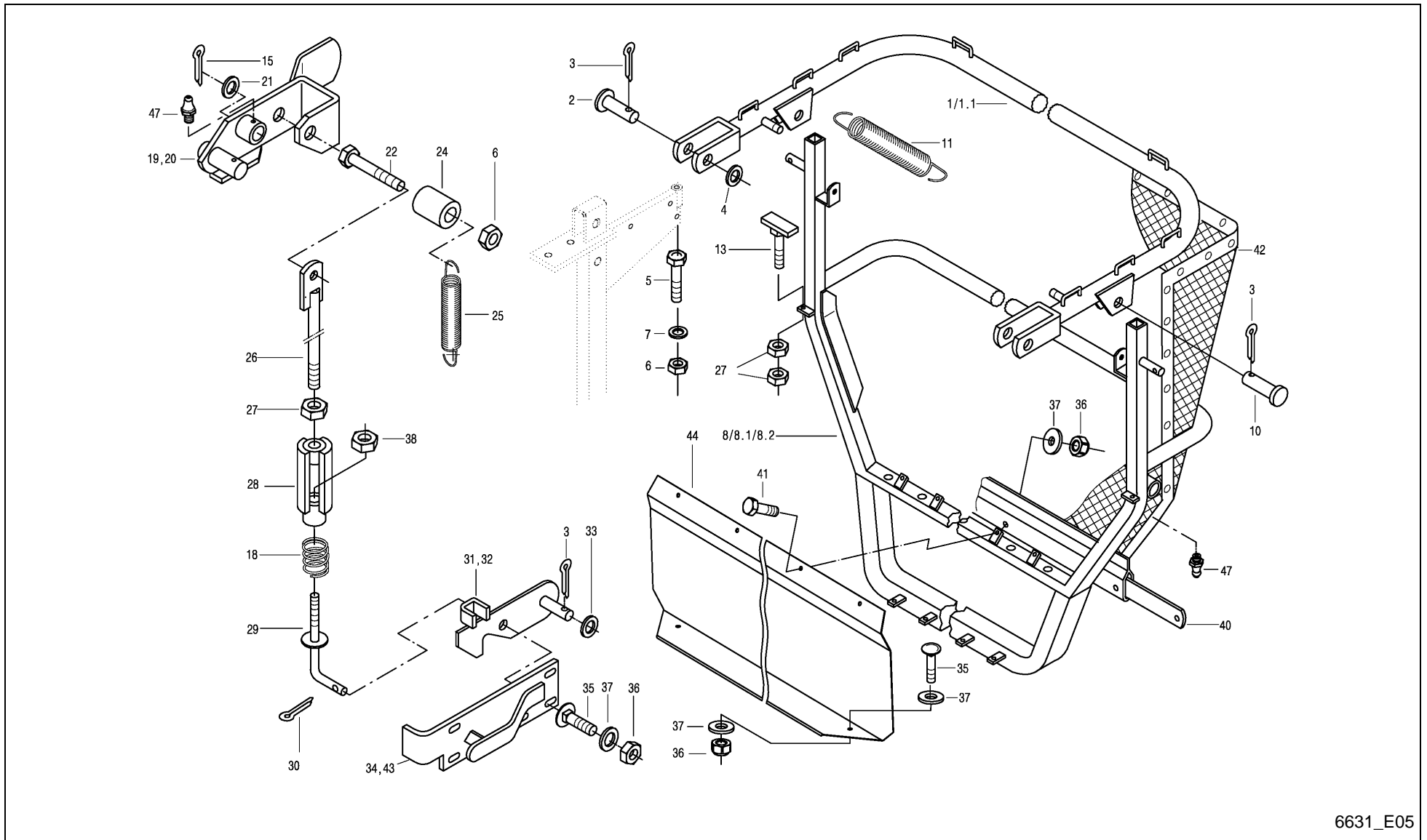

6631_E05

FeedMaster 3600T / HYDR. ADJUSTEMENT OF BACK NET UNIT



PosNo.	Part No.	Qty.	Description	Remark
1	VF16515938	1	FRONT YOKE	
1	VF16630236	1	TAILGATE BOW	+A 10/2001
2	VF06210032	2	BOLT DIN1434-16H11X 70X 65 FE+ZN	
3	VF01106451	4	SPLIT PIN	
4	VF06214215	2	WASHER 18X30X1,5 GALV.	
5	VF01111514	2	HEX. HEAD SCREW	
6	VF06209769	4	LOCK NUT	
7	VF06214207	2	WASHER	
8	VF16611322	1	FRONT YOKE	ersetzt durch 8.1+44
8.1	VF16630134	1	REAR WALL	
8.2	VF16630234	1	REAR WALL	+A 10/2001
10	VF01139468	2	PIN	
11	VF16611055	2	DRAW SPRING	
13	VF16630757	2	STOP	+A 01/2001
15	VF01122072	2	SPLIT PIN	
18	VF06215315	2	COMPRESSION SPRING	
19	VF16611351	1	ADJUSTING LEVER	
20	VF16611352	1	ADJUSTING LEVER	
21	VF01115021	2	WASHER	
22	VF01111527	2	HEX. HEAD SCREW	
24	VF16611418	2	PIPE/TUBE	
25	VF16611054	2	DRAW SPRING	
26	VF16611335	2	PULLROD	
27	VF01102659	6	HEX. NUT	
28	VF16611341	2	TURNBUCKLE	
29	VF16611338	2	HOOK	
30	VF01132621	2	SPLIT PIN	
31	VF16611325	1	RATCHET/PAWL	
32	VF16611326	1	RATCHET/PAWL	
33	VF01124633	2	WASHER	
34	VF16611330	1	HINGED PIECE	
35	VF01142565	17	TRUSS-HEAD SCR. M8X20 109 GALV.	
36	VF01104944	25	NY LOCK NUT 8A3CD985	
37	VF06214192	25	WASHER 8,4X25X3 GALV.	
38	VF06209768	2	LOCK NUT	
40	VF16515959	1	STRIP	
41	VF01112333	8	HEX. HEAD SCREW	
42	VF16515988	1	BACK NET	
42.1	VF16630237	1	RÜCKWANDBESPANNUNG K7,30/36/39	+A 10/2001
43	VF16611331	1	HINGED PIECE	

FeedMaster 3600T / HYDR. ADJUSTMENT OF BACK NET UNIT

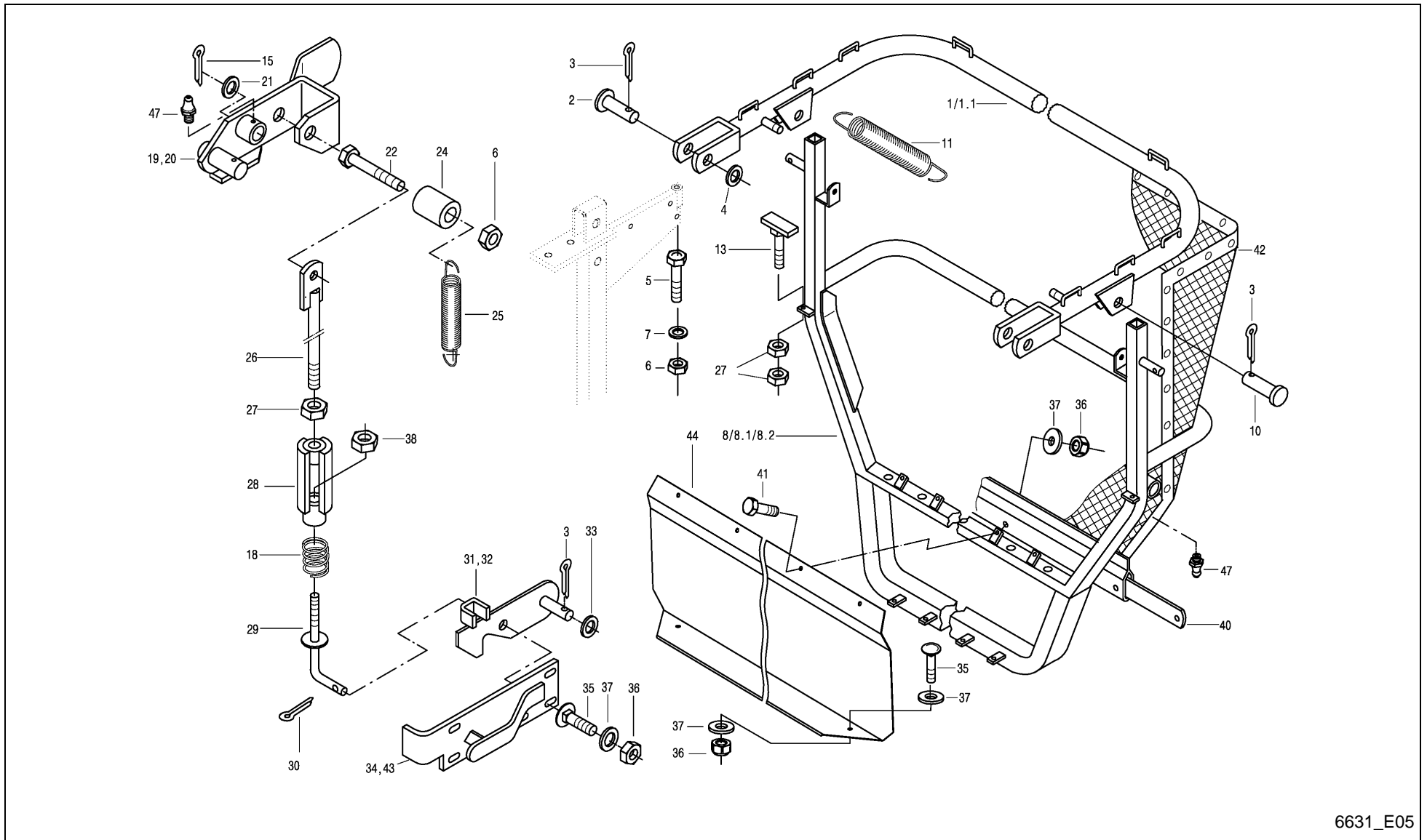

6631_E05

FeedMaster 3600T / HYDR. ADJUSTEMENT OF BACK NET UNIT



PosNo.	Part No.	Qty.	Description	Remark
44	A143031580	1	COVERING SHEET	
47	VF01120692	4	GREASE NIPPLE H1 AM 6X1 DIN 71412	

FeedMaster 3600T / DRY FORAGE SUPERST. YOKE-PROFILED TUBE

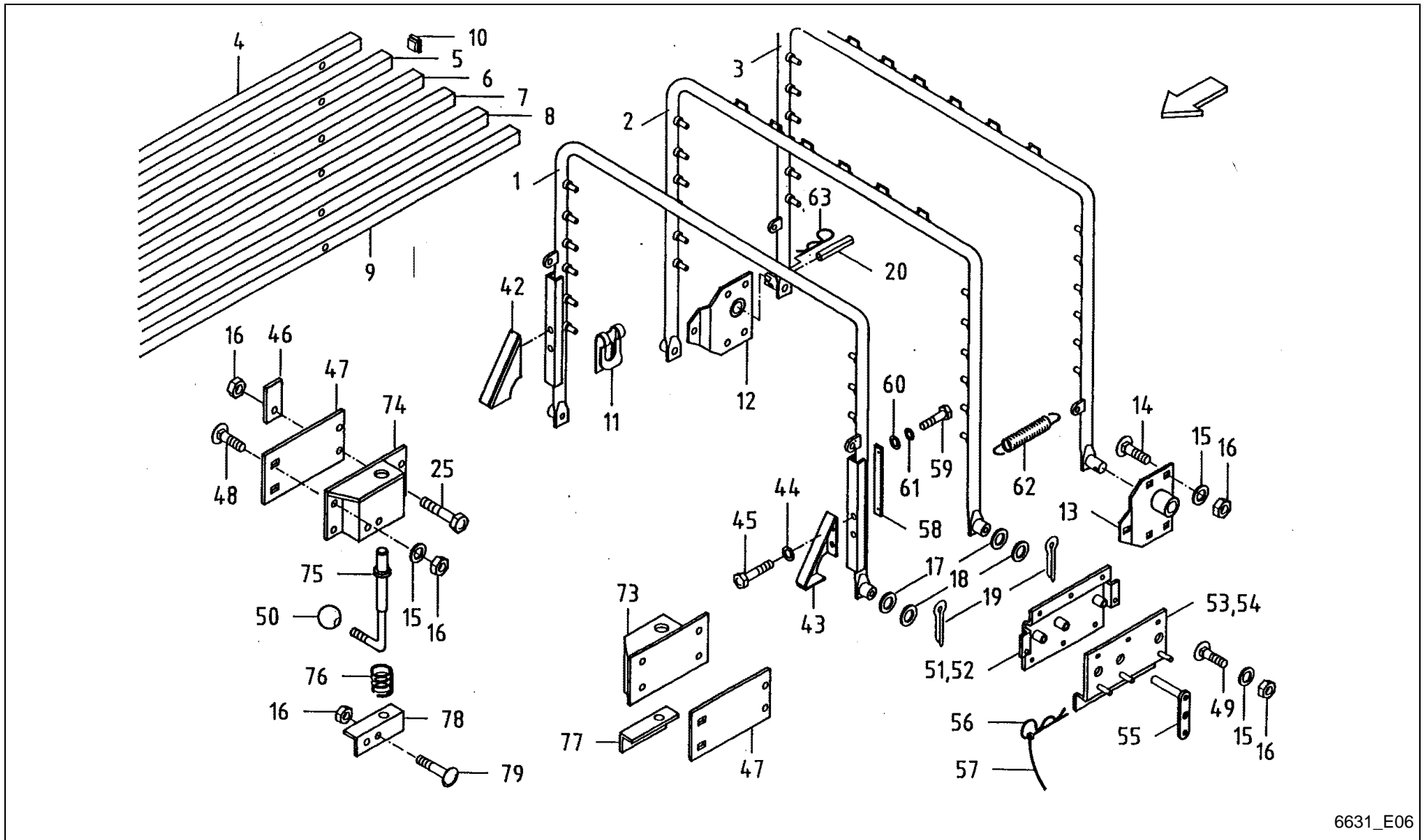

6631_E06

FeedMaster 3600T / DRY FORAGE SUPERST. YOKE-PROFILED TUBE



PosNo.	Part No.	Qty.	Description	Remark
1	VF16613405	1	YOKE	
2	VF16613406	1	YOKE	
3	VF16613408	1	YOKE	
4	VF16613409	2	PROFILED TUBE	
5	VF16613410	2	PROFILED TUBE	
6	VF16613411	2	PROFILED TUBE	
7	VF16613412	2	PROFILED TUBE	
8	VF16613413	2	PROFILED TUBE	
9	VF16613499	2	PROFILED TUBE	
10	VF16611490	24	SQUARE PLUG	
11	VF06214633	36	SEEGER RING	
12	VF06577154	1	BEARING	
13	VF06577152	1	BEARING	
14	VF06207534	10	SCREW	
15	VF06214192	26	WASHER 8,4X25X3 GALV.	
16	VF01104944	34	NY LOCK NUT 8A3CD985	
17	VF06214229	5	WASHER 21X32X2 GALV.	
18	VF06214228	4	WASHER 21X32X1 GALV.	
19	VF01122072	5	SPLIT PIN	
20	VF01157337	1	DOWEL PIN	
25	VF01112341	4	HEX. HEAD SCREW	
42	VF16614921	1	ANGLED STOP	
43	VF16614920	1	ANGLED STOP	
44	VF01107105	8	WASHER	
45	VF06209465	4	SCR. M10X20D933 8.8 GALV. DIN267-27	
46	VF06577183	2	SPACER	
47	VF16613464	2	PLATE	
48	VF01137628	4	SAUCER HEAD SCREW	
49	VF01142856	16	CUP SQR. BOLT M8X25DIN7380-2 10.9 GALV.	
50	VF06205968	2	BALL HANDLE	
51	VF16613418	1	SUPPORT RIGHT	
52	VF16613417	1	SUPPORT LEFT	
53	VF16613422	1	SUPPORT RIGHT	
54	VF16613421	1	SUPPORT LEFT	
55	VF16613427	4	PIN	
56	VF06264206	4	SPRING	
57	VF06564448	4	CORD L= 240 COLOUR BLACK	
58	VF16613432	2	STOP	
59	VF01123749	4	HEX. HEAD SCREW	
60	VF01107095	4	WASHER 6,4DIN125 GALV.	

FeedMaster 3600T / DRY FORAGE SUPERST. YOKE-PROFILED TUBE

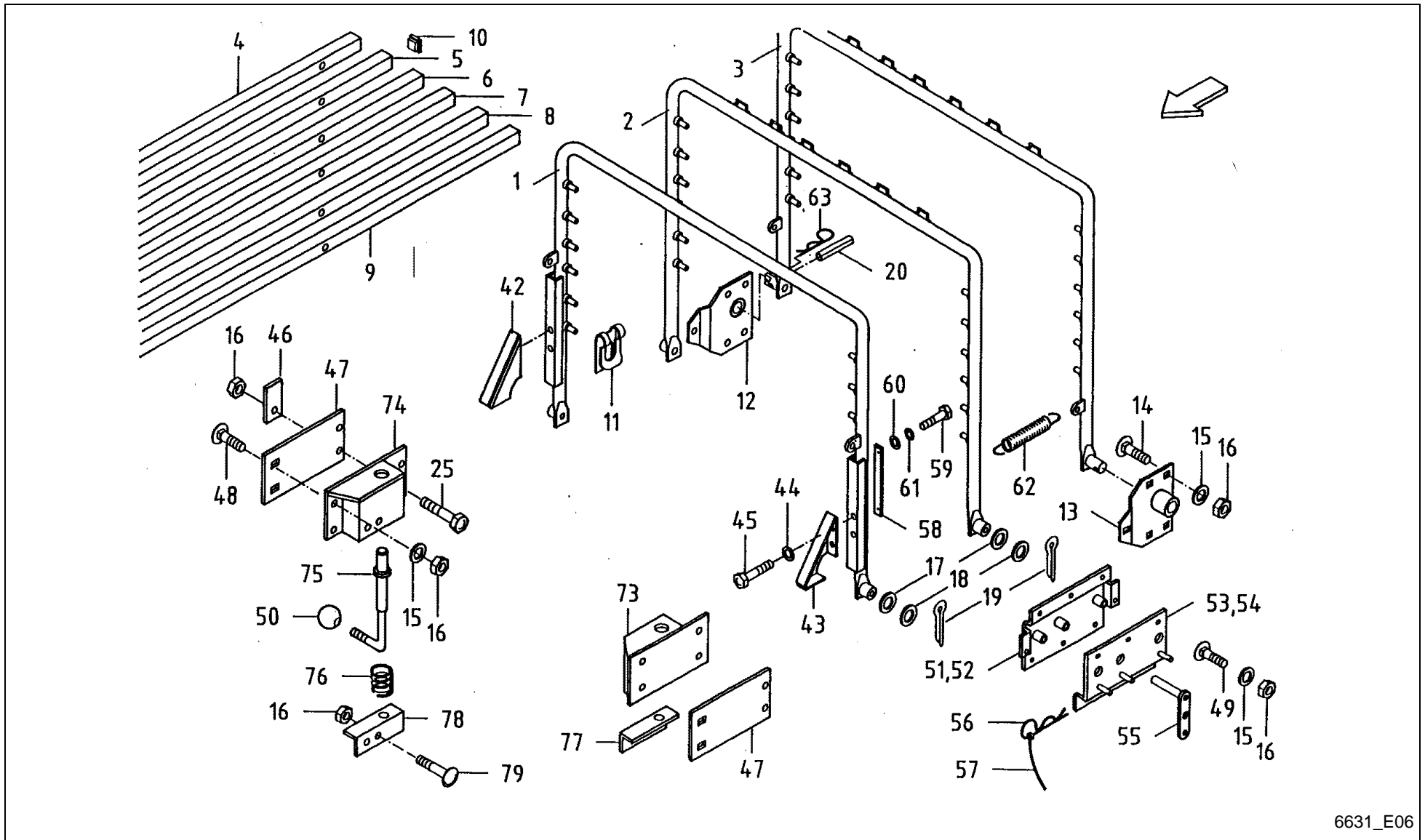

6631_E06

FeedMaster 3600T / DRY FORAGE SUPERST. YOKE-PROFILED TUBE



PosNo.	Part No.	Qty.	Description	Remark
61	VF01102797	4	SPRING WASHER	
62	VF06215565	2	TENSION SPRING 4,7 + 30,0 + 339 GA. ZI.	
63	VF06215666	1	SPRING CLIP	
73	VF06578992	1	CASE/BOX	
74	VF06578993	1	CASE/BOX	
75	VF06577192	2	FIXING PIN	
76	VF01141455	2	SPRING SUPERSTRUCTURE	
77	VF06577181	1	FIXING ANGLE	
78	VF06577182	1	FIXING ANGLE	
79	VF01108524	4	SCREW	

FeedMaster 3600T / DRY FORAGE SUPERST. CANVAS AND CABLES

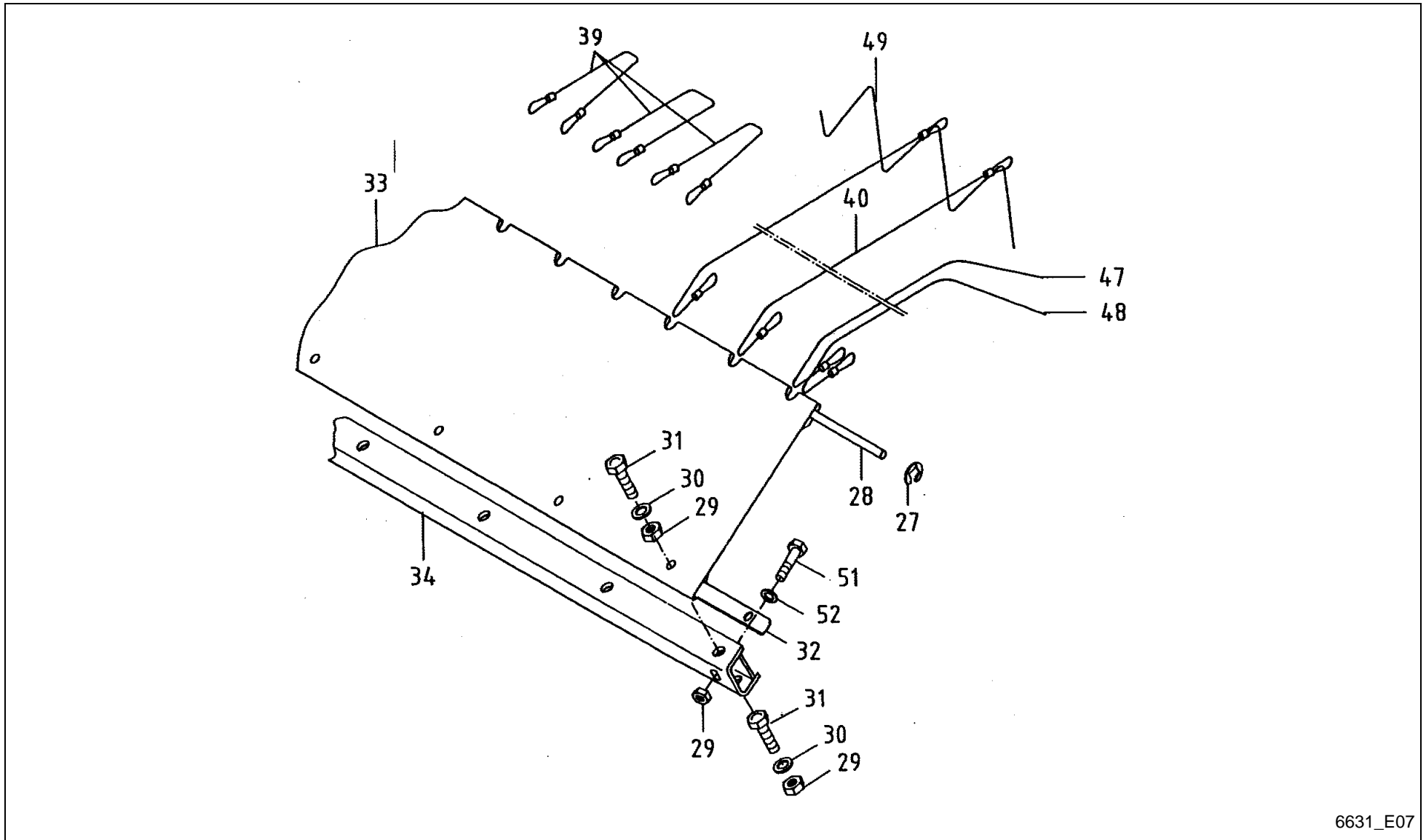

6631_E07

FeedMaster 3600T / DRY FORAGE SUPERST. CANVAS AND CABLES



PosNo.	Part No.	Qty.	Description	Remark
27	VF06587375	2	WASHER	
28	VF06587374	1	ROD	
29	VF01104944	22	NY LOCK NUT 8A3CD985	
30	VF06214192	18	WASHER 8,4X25X3 GALV.	
31	VF01112333	18	HEX. HEAD SCREW	
32	VF06577184	1	BAR	
33	VF06578646	1	FRONT CANVAS	
34	VF16613493	1	EXTENSION	
39	VF06587674	3	WIRE CABLE	
40	VF06587672	10	CABLE/ROPE	
47	VF16613469	2	CABLE/ROPE	
48	VF16613470	2	CABLE/ROPE	
49	VF16630219	1	CORD PE 6X20000MM	
51	VF01112322	4	HEX. HEAD SCREW	
52	VF01107163	8	WASHER	

FeedMaster 3600T / LEVEL INDICATOR

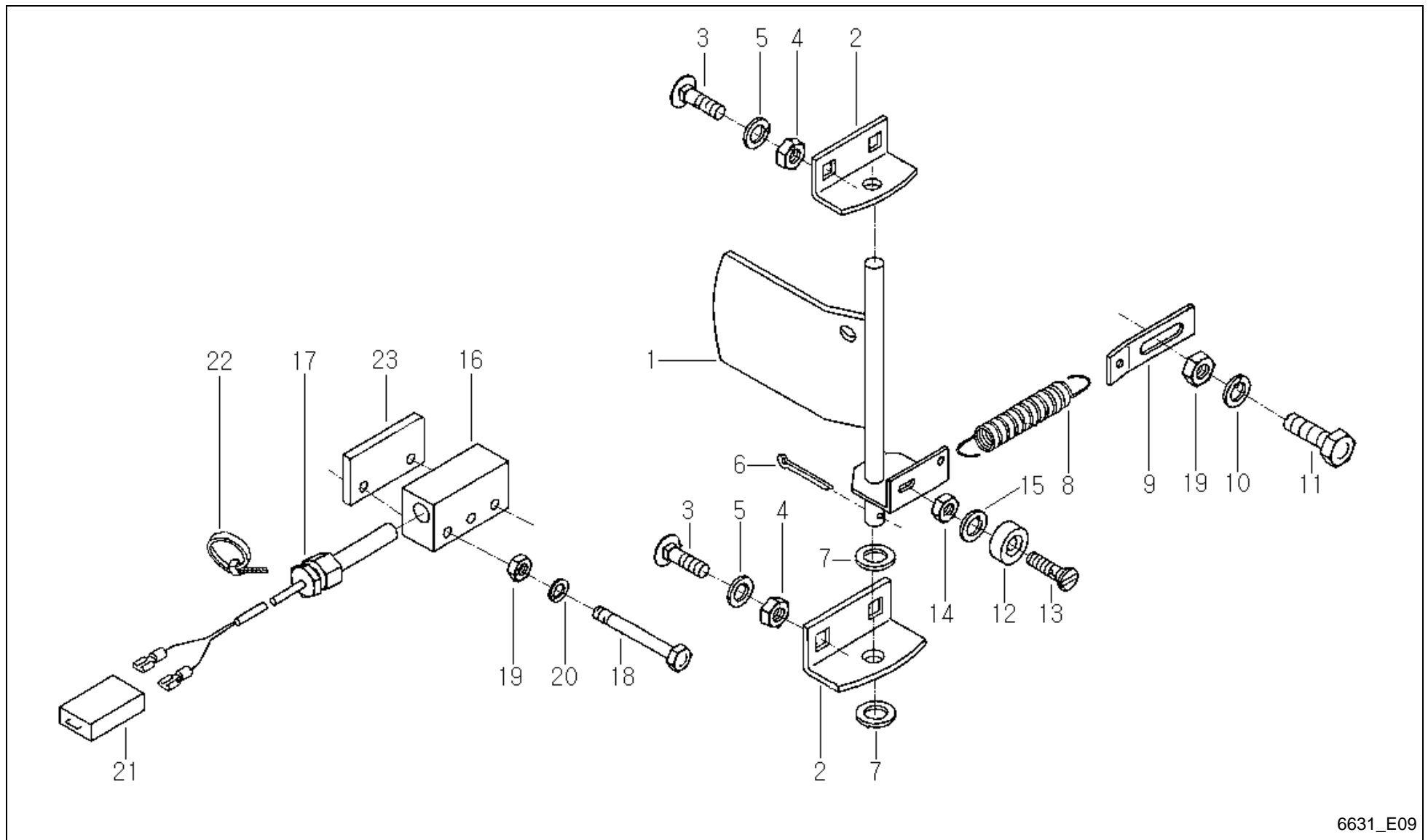

6631_E09

FeedMaster 3600T / LEVEL INDICATOR



PosNo.	Part No.	Qty.	Description	Remark
1	VF16518205	1	FLAP/COVER	
2	VF16511632	2	RETAINER	
3	VF06207535	4	OVAL HEADED BOLT	
4	VF01104944	4	NY LOCK NUT 8A3CD985	
5	VF01107163	4	WASHER	
6	VF01106451	1	SPLIT PIN	
7	VF06214215	2	WASHER 18X30X1,5 GALV.	
8	VF06215513	1	TENSION SPRING	
9	VF16511633	1	CONNECTING PLATE	
10	VF06214189	1	WASHER 6,4X18X2 A2C	
11	VF01103316	1	HEX. HEAD SCREW	
12	VF16514462	1	MAGNET/SOLENOID	
13	VF01132262	1	C SUNK SCREW	
14	VF06209764	1	HEX.NUT	
15	VF01119806	1	WASHER/DISC/PLATE	
16	VF16517215	1	SWITCH HOUSING	
17	VF16518210	1	IGNITION SWITCH	
18	VF01111083	2	HEX. HEAD SCREW	
19	VF01114357	3	LOCK NUT	
20	VF06214189	2	WASHER 6,4X18X2 A2C	
21	VF01169436		CABLE-CONNECTOR	
22	VF06216479	6	CABLE TIE 150X3,6 SW SNX 2-35	
23	VF16630487	1	DISTANCE PLATE	

FeedMaster 3600T / RIGID MOUNTING, CANVAS AND CABLES

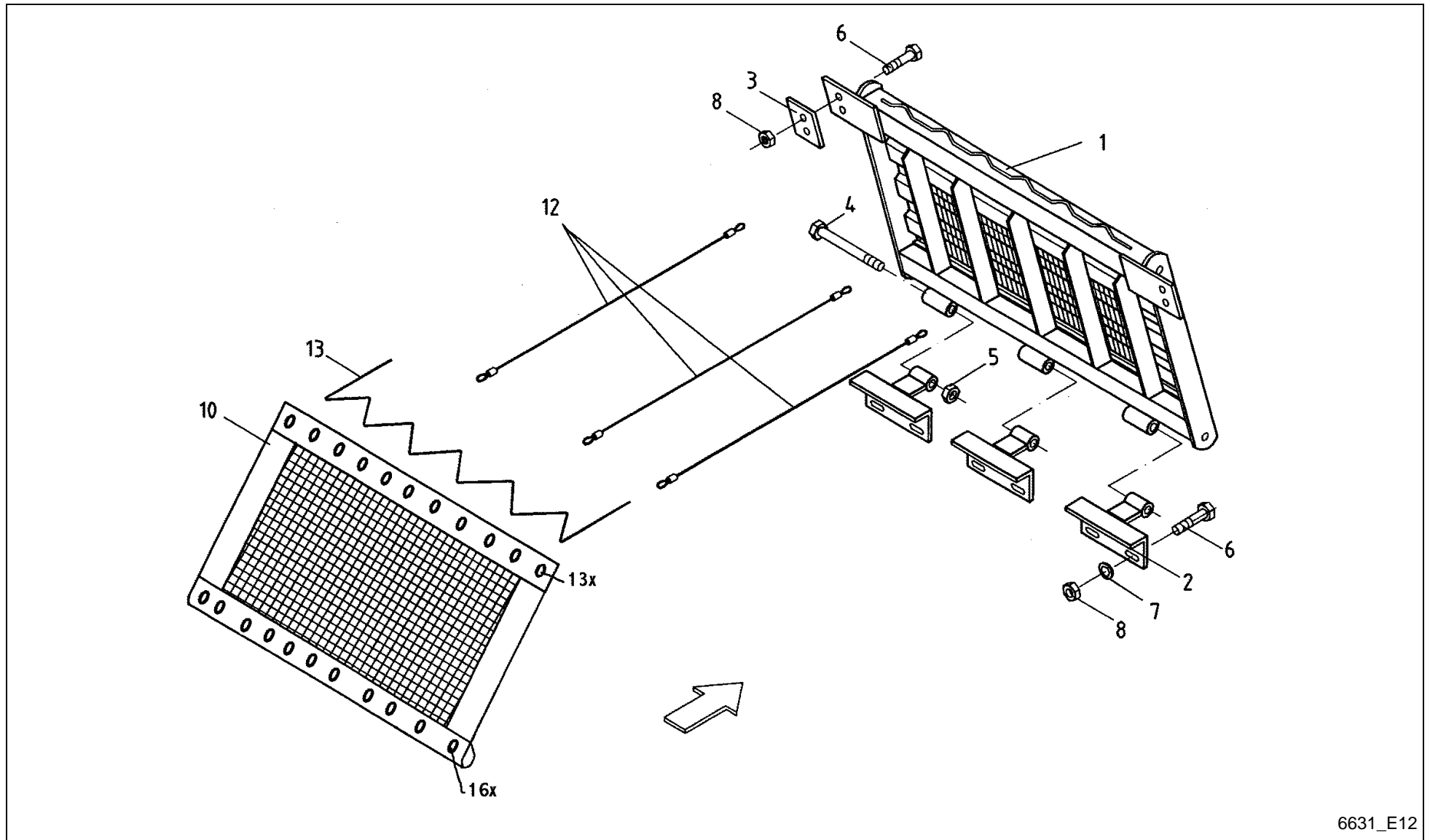

6631_E12

FeedMaster 3600T / RIGID MOUNTING, CANVAS AND CABLES



PosNo.	Part No.	Qty.	Description	Remark
1	VF16515605	1	AIR CLEANER	
2	VF16515614	3	HINGE ANGLE	
3	VF16515613	2	PACHED PLATE	
4	VF01111576	3	SCREW M 12 X 120D931 8 8A3C	
5	VF06209769	3	LOCK NUT	
6	VF01112341	10	HEX. HEAD SCREW	
7	VF06214193	6	WASHER 8,4X21X3 GALV.	
8	VF01104944	10	NY LOCK NUT 8A3CD985	
10	VF16630216	1	NET REAR	
12	VF16630217	14	CORD PE 6X4150MM	
13	VF16630219	1	CORD PE 6X20000MM	

FeedMaster 3600T / FRAME

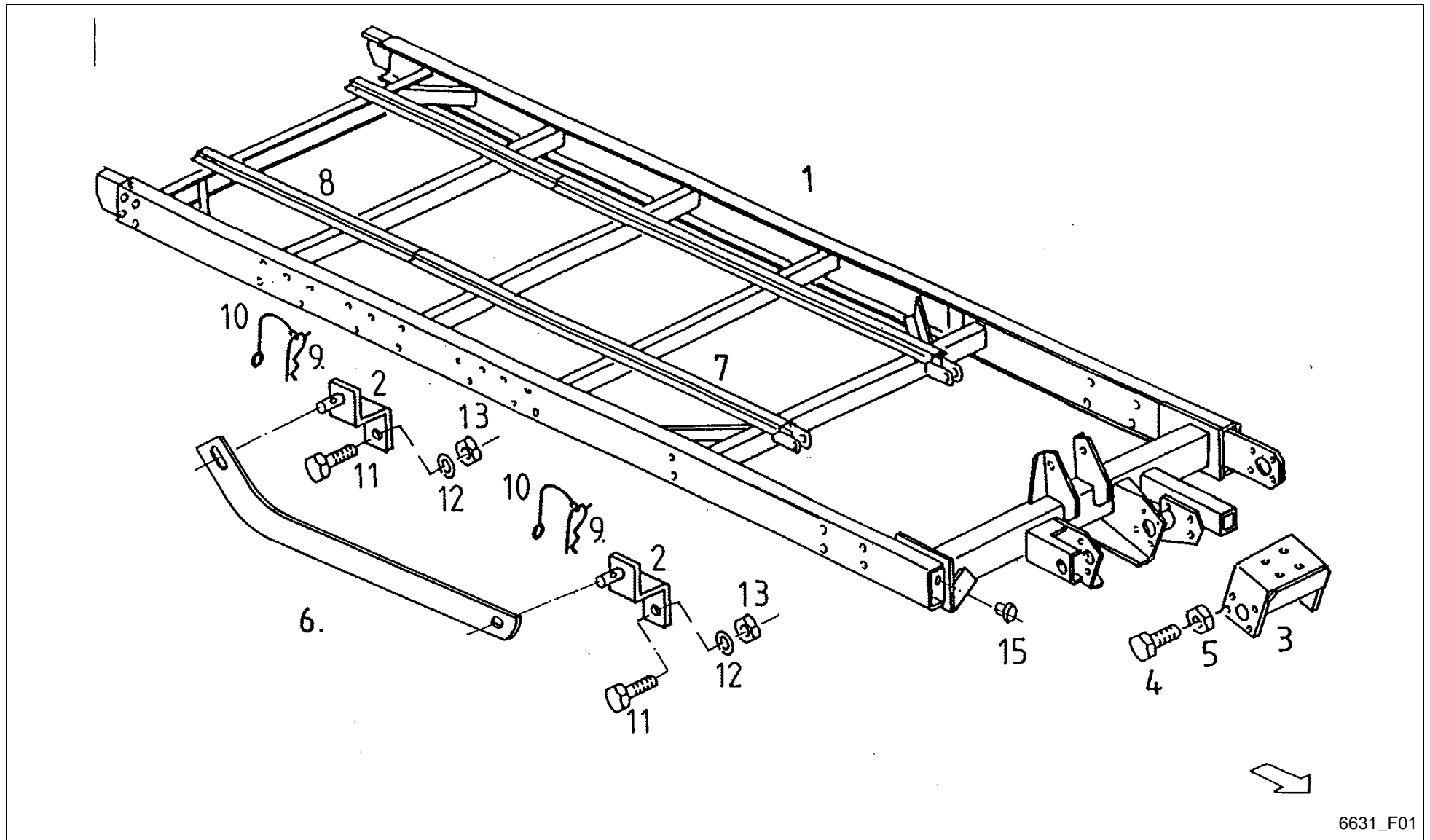

6631_F01

FeedMaster 3600T / FRAME



PosNo.	Part No.	Qty.	Description	Remark
1	VF16515716	1	CHASSIS FRAME	
2	VF16517171	2	RETAINER	
3	VF06575228	1	BRACKET	
4	VF01112683	4	HEX.HEAD SCHREW	
5	VF01127856	4	LOCK NUT	
6	VF16611366	1	LEVER	
7	VF06572550	2	GUIDE RAIL	
8	VF06558571	2	GUIDE RAIL	
9	VF06264206	2	SPRING	
10	VF06564448	2	CORD L= 240 COLOUR BLACK	
11	VF01112447	2	HEX.HEAD SCREW	
12	VF06214197	2	WASHER 10,5X30X3 GALV.	
13	VF06209768	2	LOCK NUT	
15	VF01001718	1	PLUG GPN300 F19	

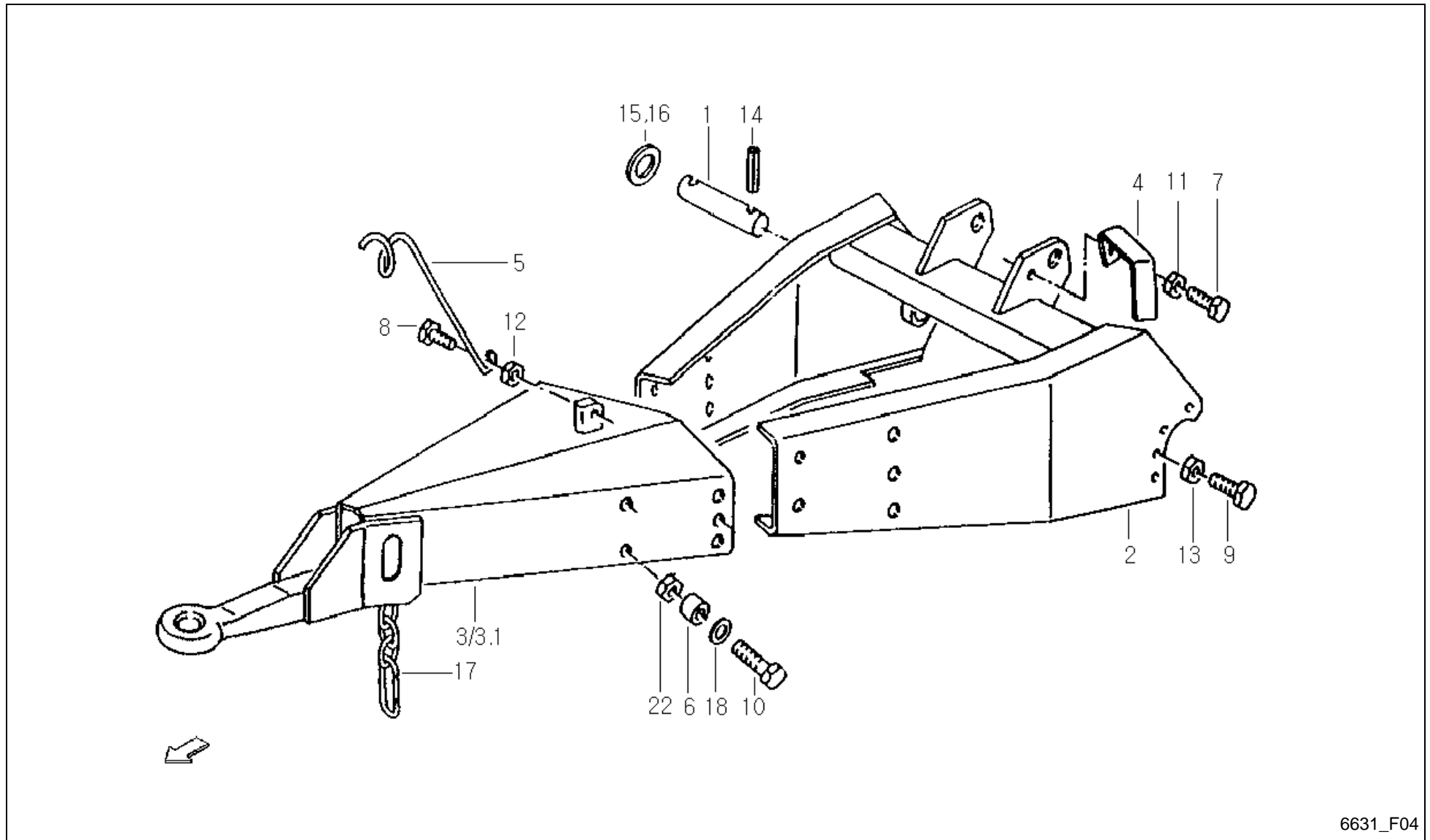

FeedMaster 3600T / DRAWBAR Z 1040



PosNo.	Part No.	Qty.	Description	Remark
1	VF06554790	1	PIN	
2	VF16631491	1	DEICHSEL GSW.	
3	VF16515251	1	HITCH/PULL ASSY.	bei TA 9t Druckluft (5-loch)
3.1	VF06556268	1	TRACTION BAR	bei EA 6t Druckluft (3-loch)
4	VF16630283	1	CLAMPING PIECE	
5	VF06558567	1	SUPPORT	
6	VF06575227	10	SPACER RING	
7	VF01112333	1	HEX. HEAD SCREW	
8	VF01112418	1	BOLT, SCREW	
9	VF01112687	4	HEX. HEAD SCREW	
10	VF01111867	8	HEX.BOLT	
11	VF01104944	1	NY LOCK NUT 8A3CD985	
12	VF06209768	1	LOCK NUT	
13	VF01127856	4	LOCK NUT	
14	VF01115478	2	DOWEL PIN	
15	VF01137526	2	WASHER	
16	VF06214486	1	SPACER 35X45X1,0 D988	
17	VF16611356	1	CHAIN 4X32 20 LINKS + SNAP HOOK	
18	VF01142556	20	SPACING RING	
19	VF01100590	10	LOCK NUT	

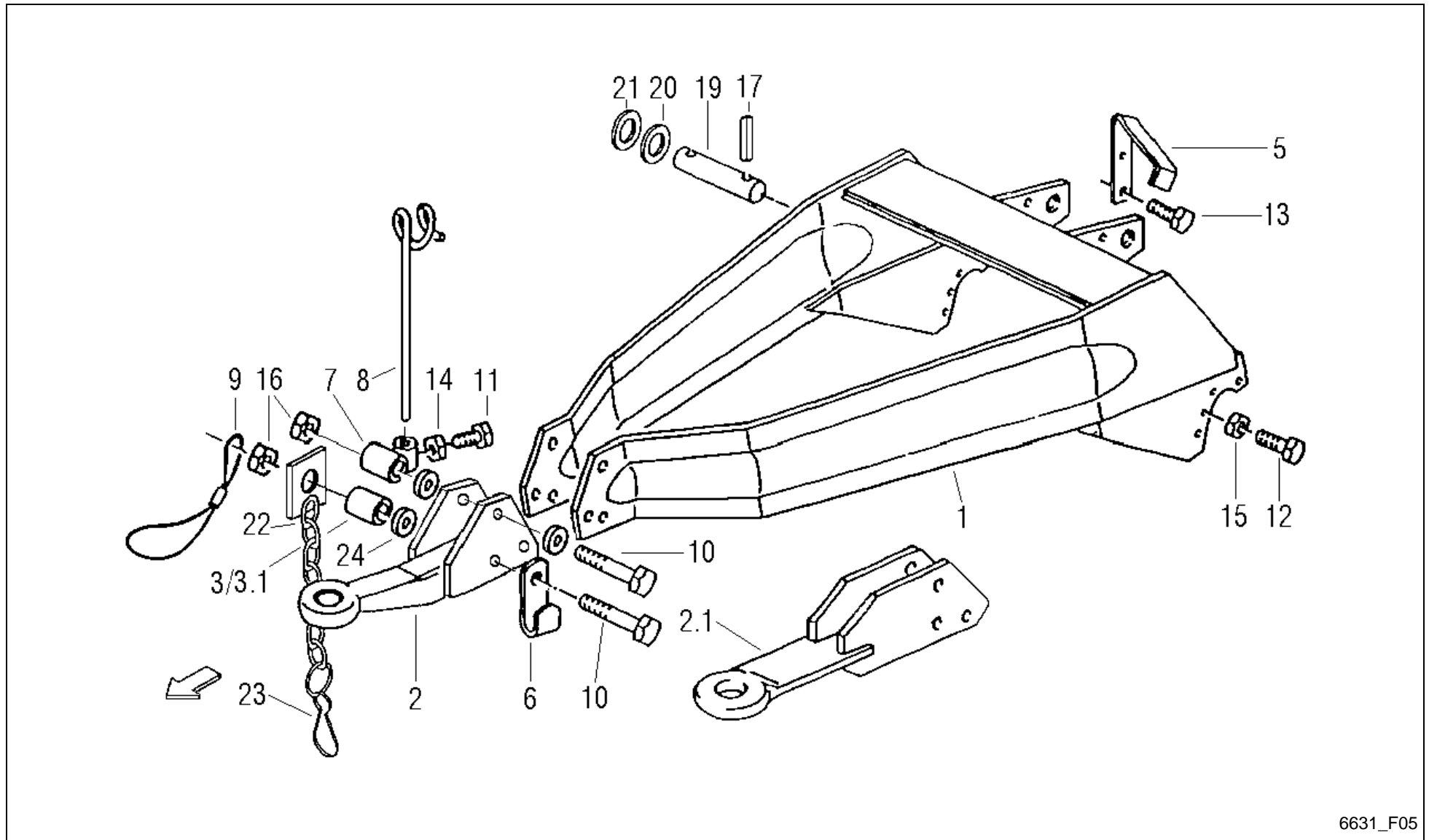

6631_F05

FeedMaster 3600T / DRAWBAR Z 450



PosNo.	Part No.	Qty.	Description	Remark
1	VF16513246	1	DRAWBAR	
2	VF16631460	1	TRACTION EYE	
2.1	VF16613273	1	DRAWBAR EYE	
3	VF06554525	1	TUBE	
3.1	VF16631478	1	PIPE	bei Pos.2 verwenden
5	VF06558560	1	CLAMPING PIECE	
6	VF06558561	1	ANGLE	
7	VF06558562	1	TUBE	
8	VF06558569	1	SUPPORT	
9	VF06587235	1	SAFETY CABLE	
10	VF01136666	2	HEX. HEAD SCREW	
11	VF01112307	1	HEX. HEAD SCREW	
12	VF01112687	4	HEX. HEAD SCREW	
13	VF06209473	2	BOLT M8X16 D933 8.8 A3C DIN267-27 COATE	
14	VF01112824	1	HEX. NUT	
15	VF01127856	4	LOCK NUT	
16	VF06209774	2	LOCK NUT	
17	VF01115478	2	DOWEL PIN	
19	VF06554790	1	PIN	
20	VF01137526	2	WASHER	
21	VF06214486	1	SPACER 35X45X1,0 D988	
22	VF16611433	1	CHAIN	
23	VF06211876	1	SNAP HOOK C60 D5299 GALV.	
24	VF06214226	3	WASHER	
25	VF01120692	1	GREASE NIPPLE H1 AM 6X1 DIN 71412	

FeedMaster 3600T / OVERR. DRAWBAR

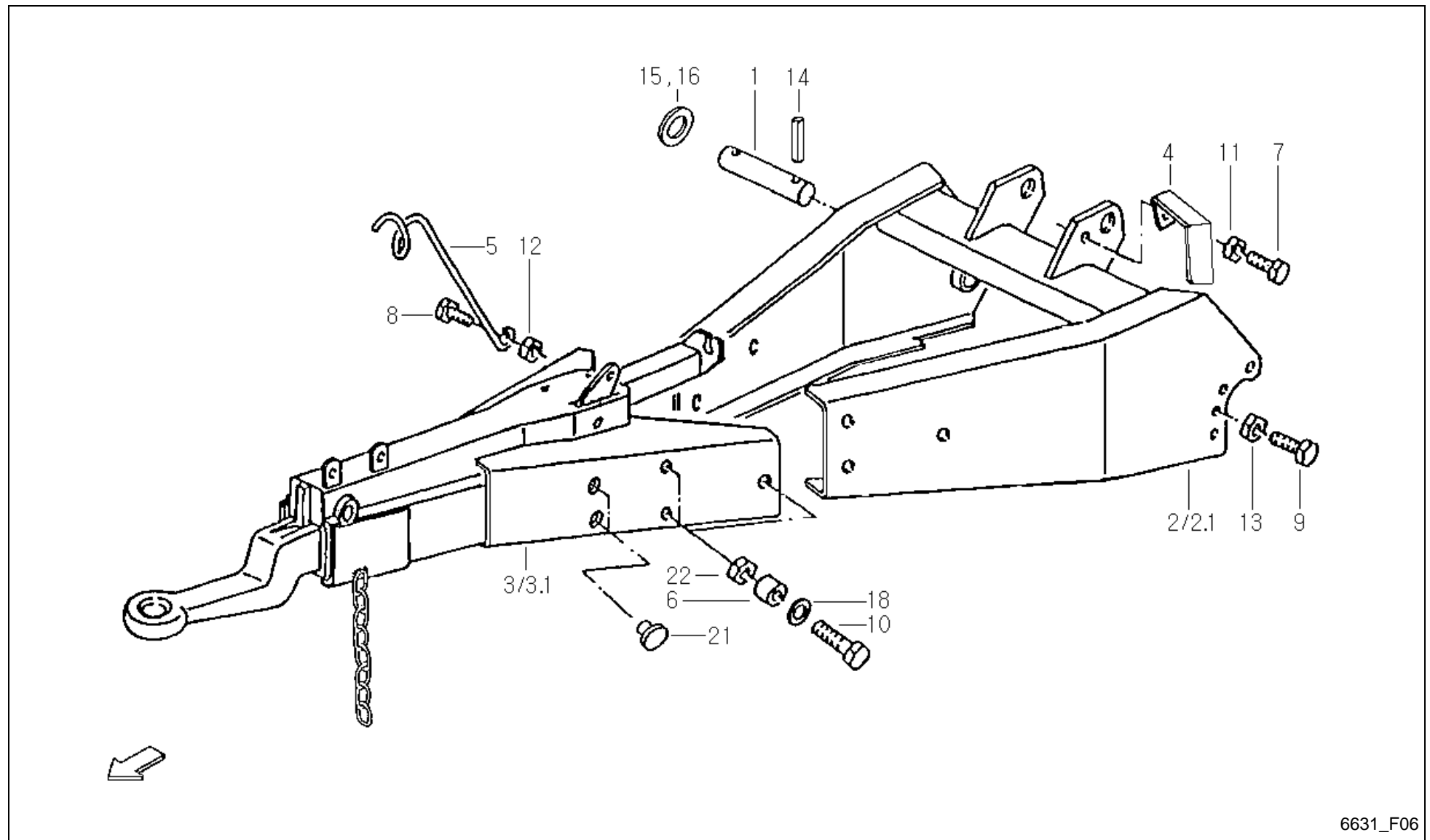

6631_F06

FeedMaster 3600T / OVERR. DRAWBAR



PosNo.	Part No.	Qty.	Description	Remark
1	VF06554790	1	PIN	
2	VF16517151	1	DRAWBAR	-A 2006
2.1	VF16631491	1	DEICHSEL GSW.	+A 2007
3	VF16613360	1	OVERRUNNING DEVICE	S F07/F08; -700
3.1	VF16630398	1	OVERRUNNING DEVICE	+701
4	VF06558565	1	CLAMPING PIECE	
5	VF06558567	1	SUPPORT	
6	VF06575227	6	SPACER RING	
7	VF01112333	1	HEX. HEAD SCREW	
8	VF01112418	1	BOLT, SCREW	
9	VF01112683	4	HEX.HEAD SCHREW	
10	VF01111867	6	HEX.BOLT	
11	VF01104944	1	NY LOCK NUT 8A3CD985	
12	VF06209768	1	LOCK NUT	
13	VF01127856	4	LOCK NUT	
14	VF01115478	2	DOWEL PIN	
15	VF01137526	1	WASHER	
16	VF06214486	1	SPACER 35X45X1,0 D988	
18	VF01142556	12	SPACING RING	
21	VF01097625	3	PLUG GPN300 F241	
22	VF01100590	6	LOCK NUT	

FeedMaster 3600T / OVERRUNNING DEVICE (-0700)

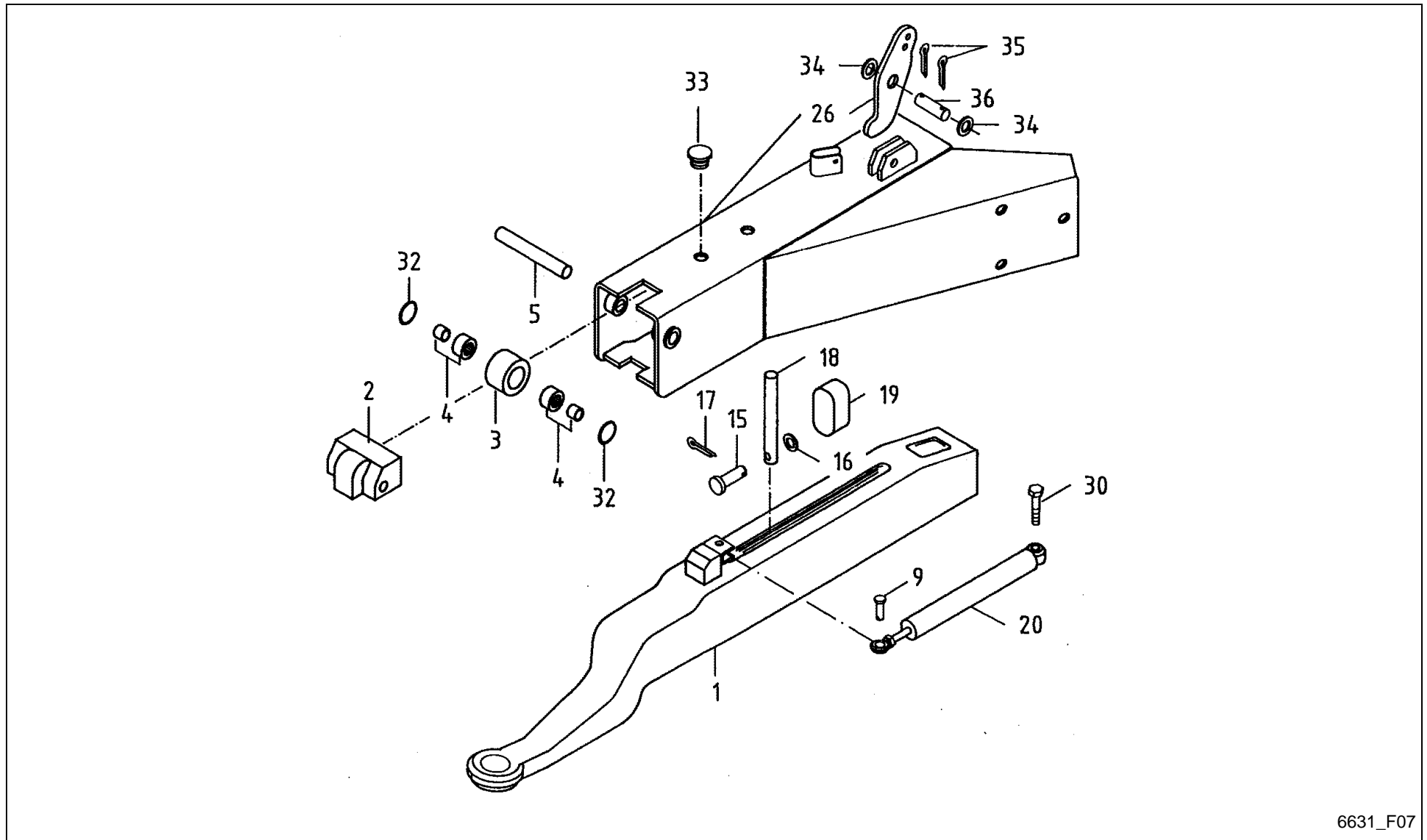

6631_F07

FeedMaster 3600T / OVERRUNNING DEVICE (-0700)



PosNo.	Part No.	Qty.	Description	Remark
1	VF16614457	1	PULLROD	
2	VF16614458	1	CAP	
3	VF16614459	1	ROLLER	
4	VF16614462	2	NEEDLE SLEEVE	
5	VF16614460	1	PIN	
9	VF16614461	1	PIN	
15	VF06210000	1	PIN	
16	VF01107101	1	WASHER 8,4DIN125 GALV.	
17	KG01248161	1	SPLIT PIN 2X16 ST	
18	VF16614463	1	STOP	
19	VF16614464	1	ABSORBER	
20	VF16614465	1	SHOCK ABSORBER	
26	VF16614469	1	REVERSING LEVER	-700
26	VF16630393	1	REVERSING LEVER	+701
30	VF01111504	1	SCREW	
32	VF16614471	2	RING	
33	VF16614470	2	NIPPLE	
34	VF06214288	2	SPACER	
35	VF01106451	2	SPLIT PIN	
36	VF06209919	1	PIN	

FeedMaster 3600T / OVERRUNNING DEVICE AVEG 2000 BPW (+0701)

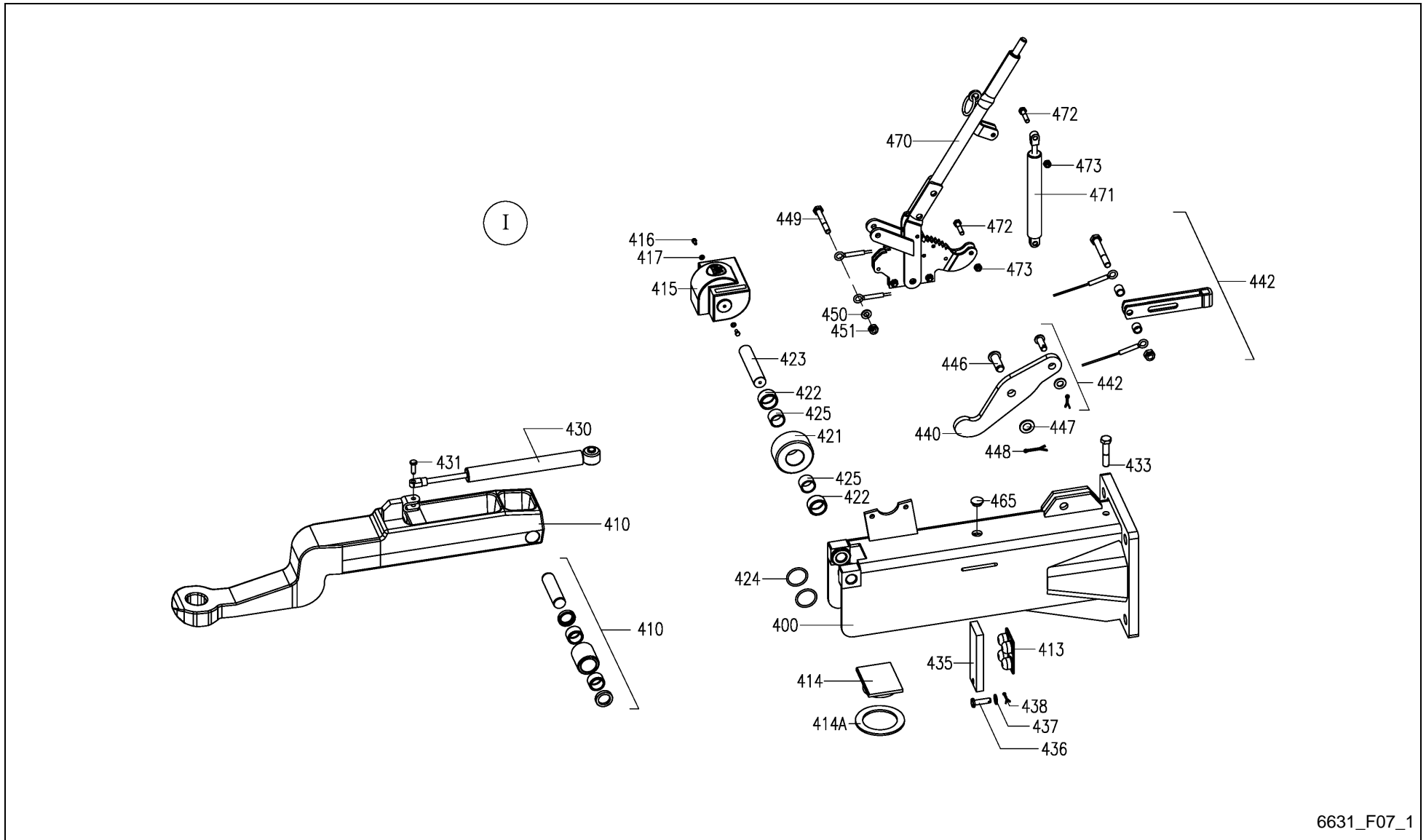

6631_F07_1

FeedMaster 3600T / OVERRUNNING DEVICE AVEG 2000 BPW (+0701)



PosNo.	Part No.	Qty.	Description	Remark
I	VF16630398	1	OVERRUNNING DEVICE	
400	A143517400	1	HOUSING	
410	VF16614457	1	PULLROD	
413	VF16614464	1	ABSORBER	
414	A143517500	1	PLATE	
414A	A143517600	1	WASHER 100/71X0,5-4,0	
415	VF16614458	1	CAP	
416	A143517700	2	HEXAGON HEAD SCREW M5X10 DIN933 8.8	
417	A143517800	2	WASHER 5,3 DIN125 200 HV	
421	VF16614459	1	ROLLER	
422	A143517900	2	NEEDLE SLEEVE HK3020 DIN618	
423	VF16614460	1	PIN	
424	A143518100	2	O-RING 35X4	
425	A143518200	2	INNER RING 25X30X20,5	
430	VF16614465	1	SHOCK ABSORBER	
431	VF16614461	1	PIN	
433	A143518300	1	HEXAGON HEAD SCREW M12X60 DIN931 8.8	
435	A143518400	1	PLATE	
436	A143518500	1	BOLT 10X35X31 DIN1434 ST	
437	A143466900	1	WASHER 10,5 DIN125 200HV	
438	A143485300	1	SPLIT PIN 3,2X16 ISO1234	
440	A143518600	1	DEFLEXION LEVER 120:85	
442	A143518700	1	BRAKE CABLE, COMPLETE	
446	A143518800	1	BOLT 16X45X38 DIN1434 ST	
447	A143518900	1	WASHER 17 DIN125 200 HV	
448	A143472600	1	SPLIT PIN 4X25 ISO1234	
449	A143519000	1	HEXAGON HEAD SCREW M10X75 DIN931 8.8	
450	A143466900	1	WASHER 10,5 DIN125 200HV	
451	A143467500	1	LOCK NUT VM10 DIN980	
465	VF16624942	1	PLUG	
470	A143519100	1	HAND BRAKE LEVER	
471	A143519200	1	DAMPER	
472	A143518000	2	HEXAGON HEAD SCREW M8X35 DIN933 8.8	
473	A143517100	2	LOCK NUT VM8 DIN980	

FeedMaster 3600T / OVERRUN BRAKE BRAKE LEVER (-0700)

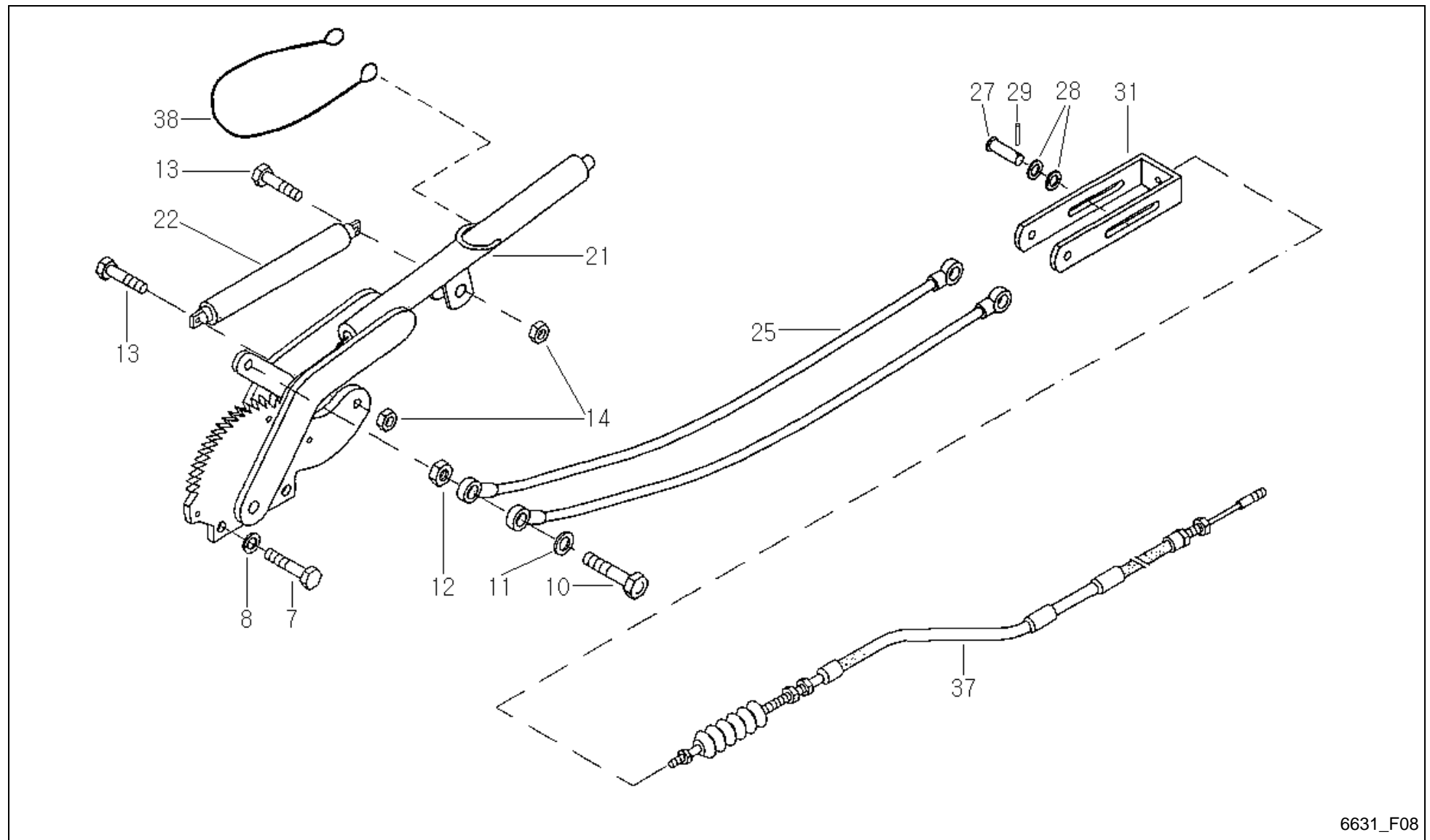

6631_F08

FeedMaster 3600T / OVERRUN BRAKE BRAKE LEVER (-0700)



PosNo.	Part No.	Qty.	Description	Remark
7	VF01112333	2	HEX. HEAD SCREW	
8	VF01102799	2	SPRING WASHER	
10	VF01111336	1	HEX.HEAD SCREW	
11	VF01107105	1	WASHER	
12	VF01102659	1	HEX. NUT	
13	VF01112350	2	HEX. HEAD SCREW	
14	VF01112824	2	HEX. NUT	
21	VF16614466	1	HAND BRAKE LEVER	
22	VF16614467	1	GAS-FILLED DAMPFER	
25	VF16614468	1	BRAKE CABLE	
27	VF06210015	1	PIN	
28	VF06214207	2	WASHER	
29	VF01106451	1	SPLIT PIN	
31	VF16614456	1	FORK	
37	VF06556619	1	BRAKE CABLE	
38	VF06587227	1	FIXING ROPE	

FeedMaster 3600T / ADJUSTING SPINDLE

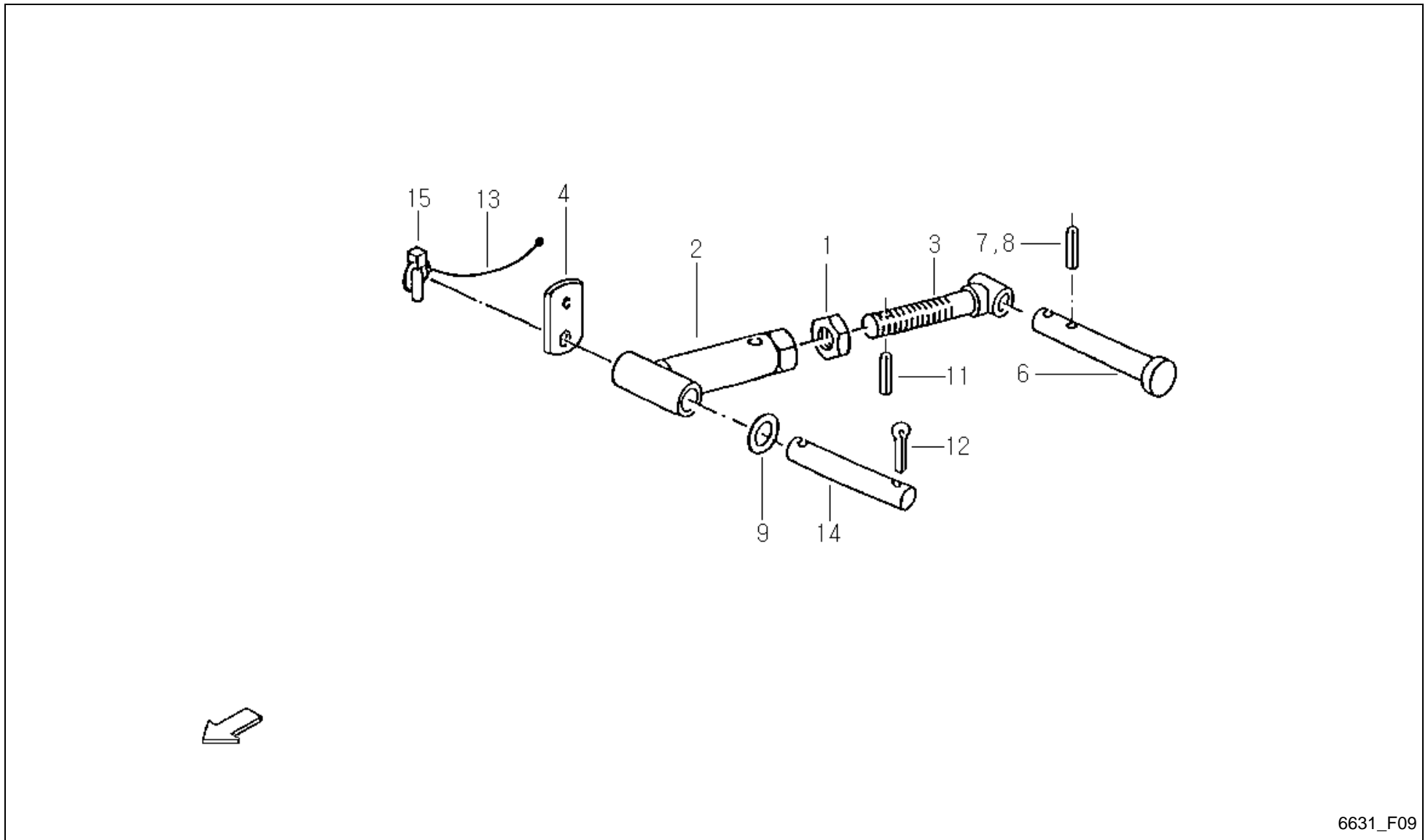

FeedMaster 3600T / ADJUSTING SPINDLE



PosNo.	Part No.	Qty.	Description	Remark
1	VF01112972	1	HEX.NUT	
2	VF16517160	1	SPINDLE	
3	VF16517144	1	THREADED SPINDLE	
4	VF16517165	1	CONNECTING PLATE	
6	VF16515159	1	PIN/BOLT/STUD	S D20 Pos. 15
7	VF01136930	1	DOWEL PIN	
8	VF01157345	1	DOWEL PIN	
9	VF06214238	1	WASHER 34X50X5 A2C DIN 1441	
11	VF01115438	1	DOWEL PIN	
12	VF01106500	1	SPLIT PIN 8X50DIN94 GALV.	
13	VF06564448	1	CORD L= 240 COLOUR BLACK	
14	VF01397597	1	PIN/BOLT/STUD	
15	VF06213664	1	FOLDING PLUG	

FeedMaster 3600T / ELECTR.REMOTE CONTR. PILOTBOX-T

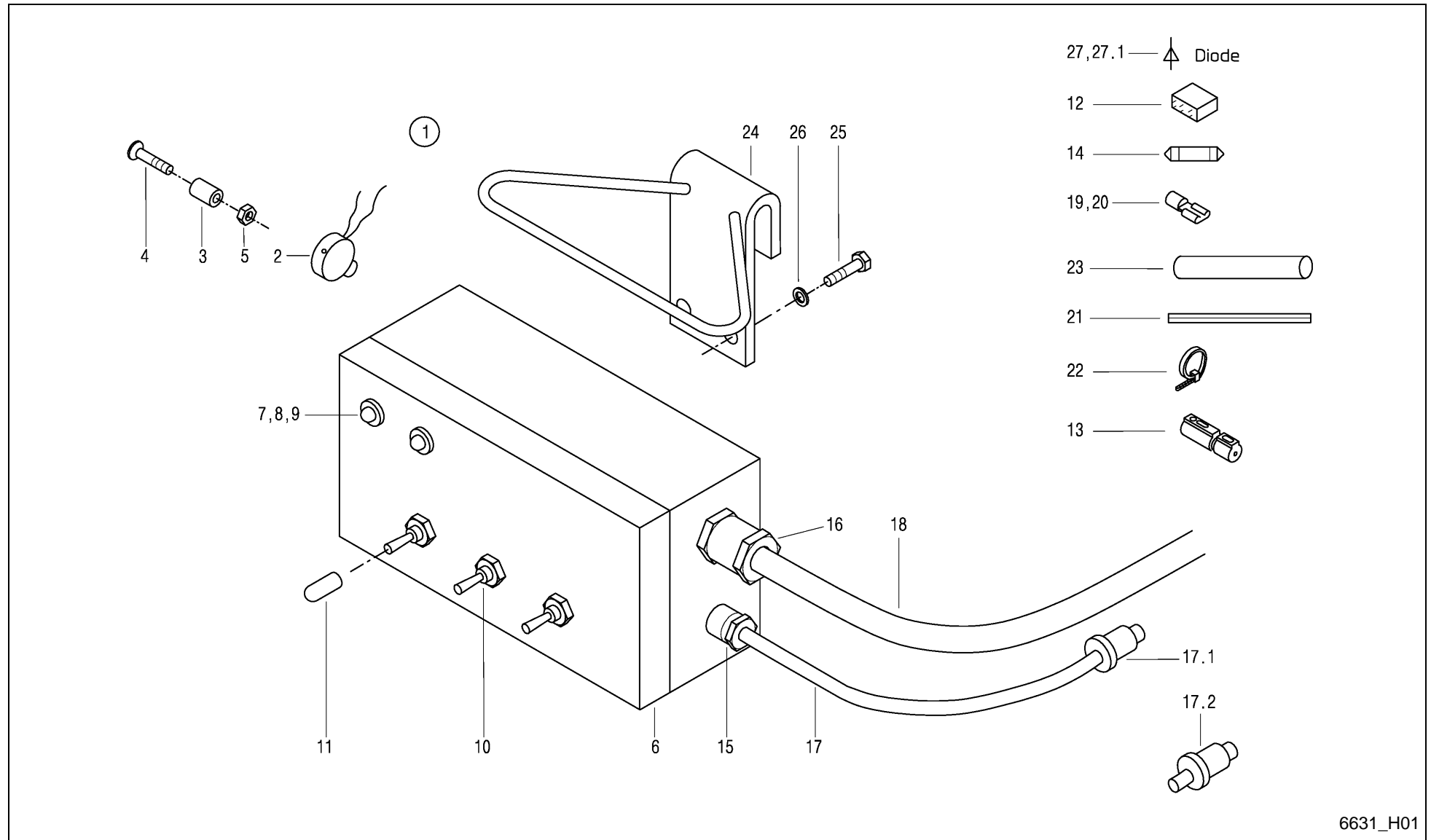

6631_H01

FeedMaster 3600T / ELECTR.REMOTE CONTR. PILOTBOX-T



PosNo.	Part No.	Qty.	Description	Remark
1	VF16613394	1	PILOTBOX-T	
2	VF06579959	1	HORN	
3	VF06579960	2	SLEEVE	
4	VF01397550	2	C'SUNK SCREW	
5	VF01143097	2	HEX.NUT	
6	VF16613387	1	HOUSING/CASE	
7	VF16613236	1	RED LAMP	
8	VF16613237	1	GREEN LAMP	
9	VF16613238	2	O-RING	
10	VF06579979	3	TOGGLE SWITCH	
11	VF16515453	3	CAP	
12	VF01164017	1	RELAY	
13	VF06587052	1	SUPPORT	
14	VF01143017	1	FUSE	
15	VF06213737	1	UNION	
16	VF01151892	1	THREADED UNION	
17	VF06579961	1	CABLE	mit Pos.17.1
17.1	VF01101600	1	PLUG	
17.2	VF16518524	1	PLUG CONTACT 3-POLE BIS 25A DIN 9680	alternativ
18	VF01142889	1	ELECTRIC LINES	
19	VF01397896	13	PLUG-IN SLEEVE	
20	VF01397920	15	PLUG-IN SLEEVE	
21	VF01403239	1	ELECTRIC LINES	
22	VF06216479	3	CABLE TIE 150X3,6 SW SNX 2-35	
23	VF16513942	1	SHRINK HOSE	
24	VF16515468	1	YOKE/RETAINER	
25	VF01112240	2	HEX. HEAD SCREW	
26	VF01118645	2	SEAL RING	
27	VF16511469	5	DIODE	
27.1	VF16513933	1	DIODE	+451

FeedMaster 3600T / ELECTR. EGUPM. DISTRIBUTION BOX

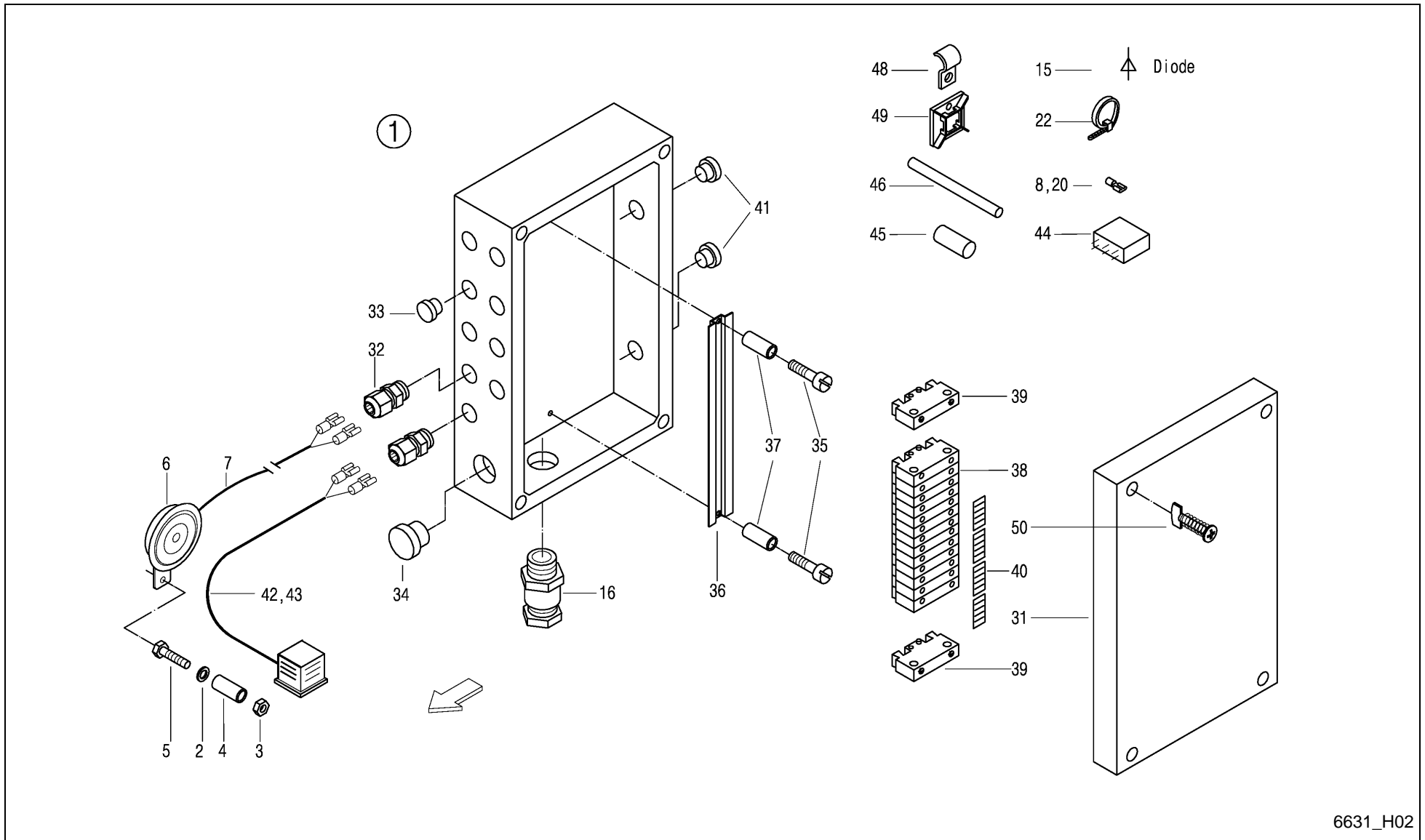

6631_H02

FeedMaster 3600T / ELECTR. EGUPM. DISTRIBUTION BOX



PosNo.	Part No.	Qty.	Description	Remark
1	VF16613396	1	DISTRIBUTION BOX	
2	VF01107163	2	WASHER	-A 2005
3	VF01104944	1	NY LOCK NUT 8A3CD985	-A 2005
4	VF16606570	1	FIXING TUBE GALV. L=48 RO.16X2.5	-A 2005
5	VF01111179	1	HEX.BOLD	-A 2005
6	VF06214045	1	HORN	-A 2005
7	VF16611480	1	CABLE	-A 2005
8	VF01397896	2	PLUG-IN SLEEVE	
15	VF16511469	5	DIODE	
16	VF01151892	1	THREADED UNION	
20	VF01397920	17	PLUG-IN SLEEVE	
22	VF06216479	13	CABLE TIE 150X3,6 SW SNX 2-35	
31	VF16517792	1	HOUSING	
31.1	VF16611275	4	QUICK FASTENER	
32	VF02953409	6	THREADED UNION	
33	VF01397704	4	BLANK PLUG	
34	VF02953408	1	BLANK PLUG	
35	VF01105571	2	CHEESE-HEAD SCREW	
36	VF16517922	1	SUPPORT RAIL	
37	VF16517923	2	SLEEVE	
38	VF16515446	14	TERMINAL	
39	VF16515448	2	END HOLDER	
40	VF16517917	1	LETTERING	
41	VF02953410	2	NIPPLE	
42	VF16518970	4	PIPE/LINE/LEAD	
42	VF01128192	6	CABLE END SOCKET	
42.1	VF06579981	3	TIN	
42.2	VF06579982	3	SECTIONAL SEAL	
43.3	VF16611079	3	INSCRIPTION PLATE	
44	VF16613243	1	RELAY	
45	VF16611081	1	SHRINK HOSE	
46	VF01404321	2	SHRINK HOSE	
48	VF06216397	2	FIXING CLIP	
49	VF16613283	2	CABLE RETAINER	
50	VF01397598	2	SELF-TAPPING SCREW	

FeedMaster 3600T / ELECTR. EQUIPM. LIGHTING



PosNo.	Part No.	Qty.	Description	Remark
1	VF16516330	1	ELECTRIC LINES	
2	VF06213977	1	CABLE CONNECTOR	
3	VF01397870	1	TAIL LIGHT	
4	VF01397871	1	TAIL LIGHT	
5	VF01102550	2	TABULAR LAMP12V 21W D72601	
6	VF01135950	2	BULB	
7	VF01105524	8	CHEESE HEAD SCREW	
8	VF06209765	8	LOCK NUT M5 8 GALV. DIN985	
9	VF04308511	2	REAR REFLECTOR	
10	VF16631249	2	TRIANGLE REAR REFLECTOR	
11	VF06577068	1	CABLE	
12	VF06278838	1	RUBBER GROMMET	
13	VF06216479	35	CABLE TIE 150X3,6 SW SNX 2-35	
14	VF01102797	4	SPRING WASHER	
15	VF06213973	1	CONNECTING PIECE	
16	VF01103316	4	HEX. HEAD SCREW	
17	VF16515977	2	LIGHT RETAINER	
18	VF16516333	1	ELECTRIC LINES	
19	VF01114357	4	LOCK NUT	
20	VF06214041	2	REFLECTOR WHITE D80 WITH HOLE 5.5	
21	VF01105526	4	CYL. SCREW AM 5X16 DIN 84 - A3C -4.8	
22	VF01102796	4	SPRING WASHER	
23	VF01112803	4	HEX. NUT M5	
24	VF16635245	1	BEACON	Option Rundumkennleuchte
25	VF16635247	1	ANGLE PLATE,	Option Rundumkennleuchte
26	VF01112264	4	HEX. HEAD SCREW	Option Rundumkennleuchte
27	VF06214189	8	WASHER 6,4X18X2 A2C	Option Rundumkennleuchte
28	VF01114357	4	LOCK NUT	Option Rundumkennleuchte
29	VF16635249	3	SCREW 4.8X16	Option Rundumkennleuchte

FeedMaster 3600T / ELECTR. EQUIPM. BACK NET

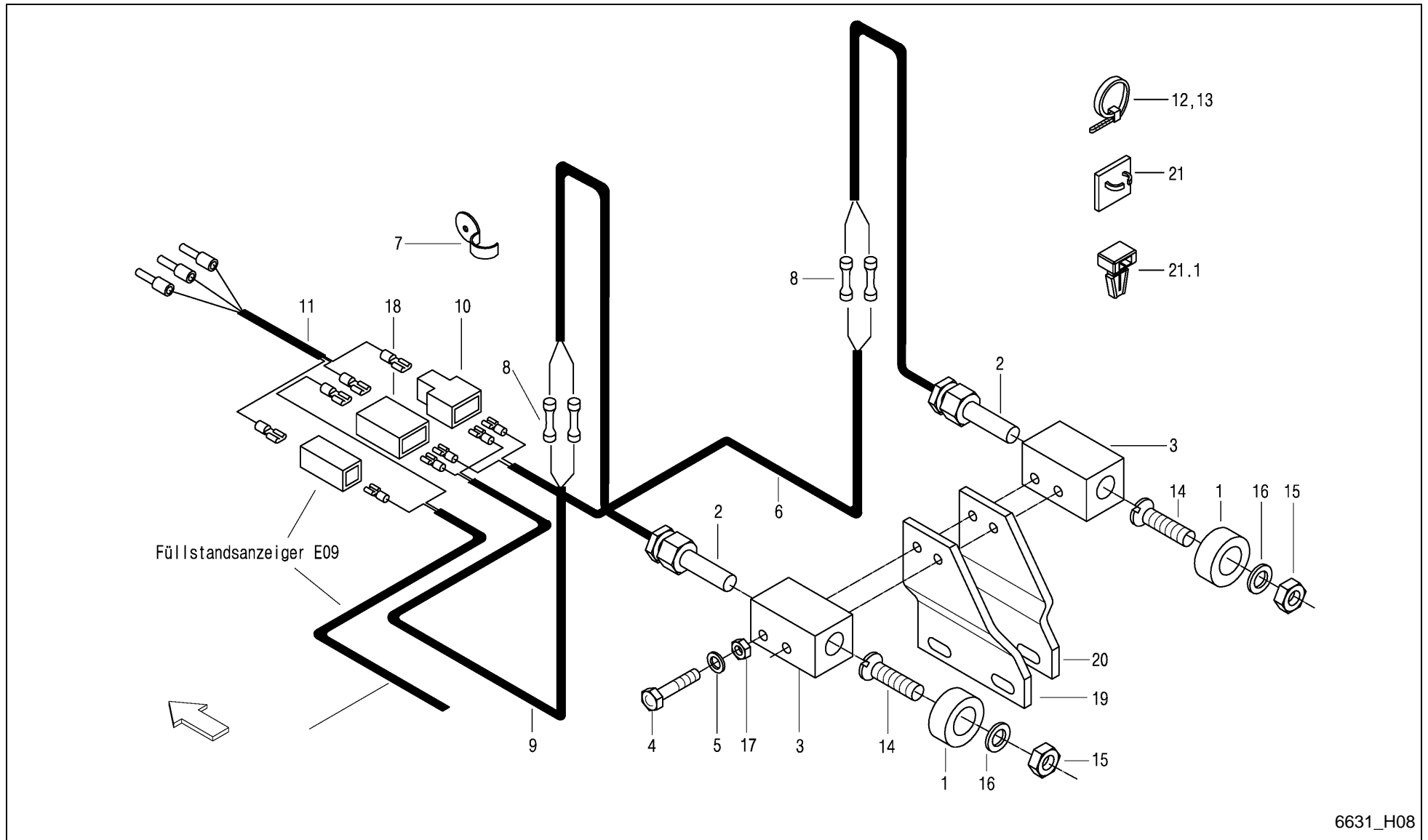

6631_H08

FeedMaster 3600T / ELECTR. EQUIPM. BACK NET



PosNo.	Part No.	Qty.	Description	Remark
1	VF16512287	2	MAGNET	
2	VF16514460	2	SWITCH	
3	VF16517215	2	SWITCH HOUSING	
4	VF01111071	4	HEX. HEAD SCREW	
5	VF01107095	4	WASHER 6,4DIN125 GALV.	
6	VF16516335	1	ELECTRIC LINES	
7	VF06216396	4	HOSE CLIP	
8	VF01397855	4	CONNECTOR/UNION	
9	VF16516337	1	ELECTRIC LINES	
10	VF06213974	1	PLUG CONNECTION	
11	VF16515739	1	ELECTRIC LINES	
12	VF06216479	6	CABLE TIE 150X3,6 SW SNX 2-35	
13	VF06216480	2	CABLE TIE 368X4,8 SW SNX 3-100	
14	VF01132294	2	SCR. M5X25 D963 48 GALV.	
15	VF06209765	2	LOCK NUT M5 8 GALV. DIN985	
16	VF01107158	2	WASHER	
17	VF01114357	4	LOCK NUT	
18	VF06213982	1	CLUTCH PIECE	
19	VF16611318	1	BASE PLATE	
20	VF16611317	1	BASE PLATE	
21	VF16613283	6	CABLE RETAINER	-A 2004
21.1	VF16631248	6	EXPANSION ANCHOR	+A 2005

FeedMaster 3600T / PICK-UP 1.6 SCRAPER

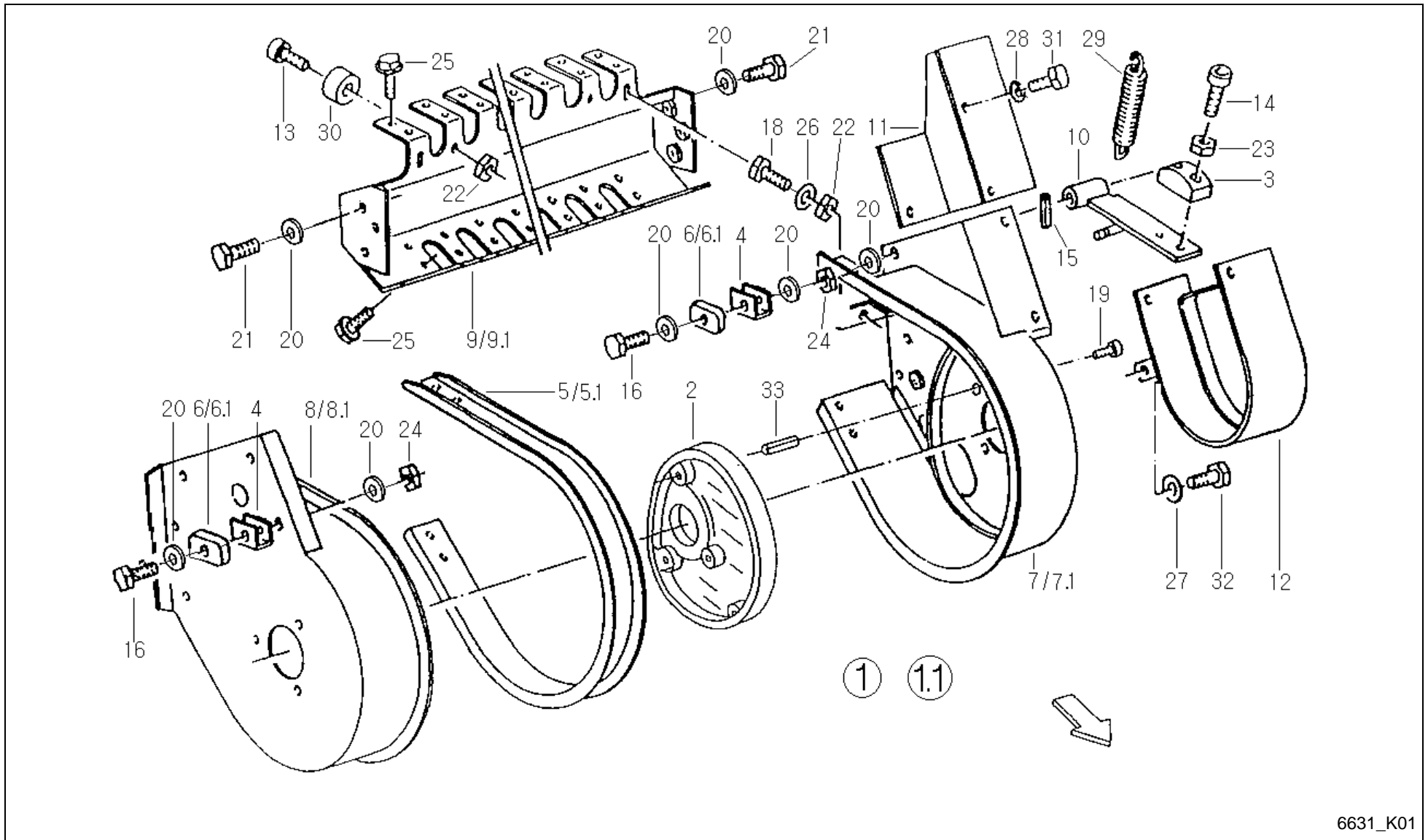

6631_K01

FeedMaster 3600T / PICK-UP 1.6 SCRAPER



PosNo.	Part No.	Qty.	Description	Remark
1	VF16513250	1	PICK-UP	-540
1.1	VF16630125	1	PICK-UP 5 REEL	+541
2	VF06296264	1	STEERING PLATE	
3	VF06571134	1	TENSION-BLOCK	X 10
4	VF06571322	3	YOKE	
5	VF06577405	25	SHEET	-540
5.1	VF16630114	25	SCRAPER	+541
6	VF06571323	6	STOP	
6.1	VF16635132	1	LIMIT STOP	+A 2012
7	VF06571005	1	SIDE PART	-540
7.1	VF16630115	1	SIDE PLATE LEFT	+541
8	VF06577426	1	SIDE MEMBER	-540
8.1	VF16630119	1	SIDE PLATE RIGHT	+541
9	VF06570920	1	SUPPORT	-540
9.1	VF16630112	1	SUPPORT	+541
10	VF06571094	1	CHAIN TENSIONER	
11	VF06571099	1	GUARD PLATE	
12	VF06571090	1	CHAIN/TRACK GUARD	
13	VF01105544	2	CYLINDRICAL SCREW	
14	VF01110577	2	SCREW	X 10
15	VF01115441	1	DOWEL PIN	
16	VF01111298	3	HEX. HEAD SCREW	
18	VF01112264	2	HEX. HEAD SCREW	
19	VF06209476	2	BOLT M8X30 D933 8.8 A3C DIN267-27 COATE	
20	VF01107165	12	WASHER M10 11X20X2 A2C DIN126	
21	VF01112418	6	BOLT, SCREW	
22	VF01114357	4	LOCK NUT	
23	VF01104944	2	NY LOCK NUT 8A3CD985	X 10
24	VF06209768	2	LOCK NUT	
25	VF0905191000	106	GEWINDEFURCHSCHRAUBE M 6 X 16	
26	VF06214189	4	WASHER 6,4X18X2 A2C	
27	VF01107163	1	WASHER	
28	VF01102799	3	SPRING WASHER	
29	VF06215561	1	TENSION SPRING	
30	VF06571355	2	RUBBER BLOCK	
31	VF01112322	3	HEX. HEAD SCREW	
32	VF01112307	1	HEX. HEAD SCREW	
33	VF16614668	1	PIN, TENSION	

FeedMaster 3600T / PICK-UP 1.6 DRUM

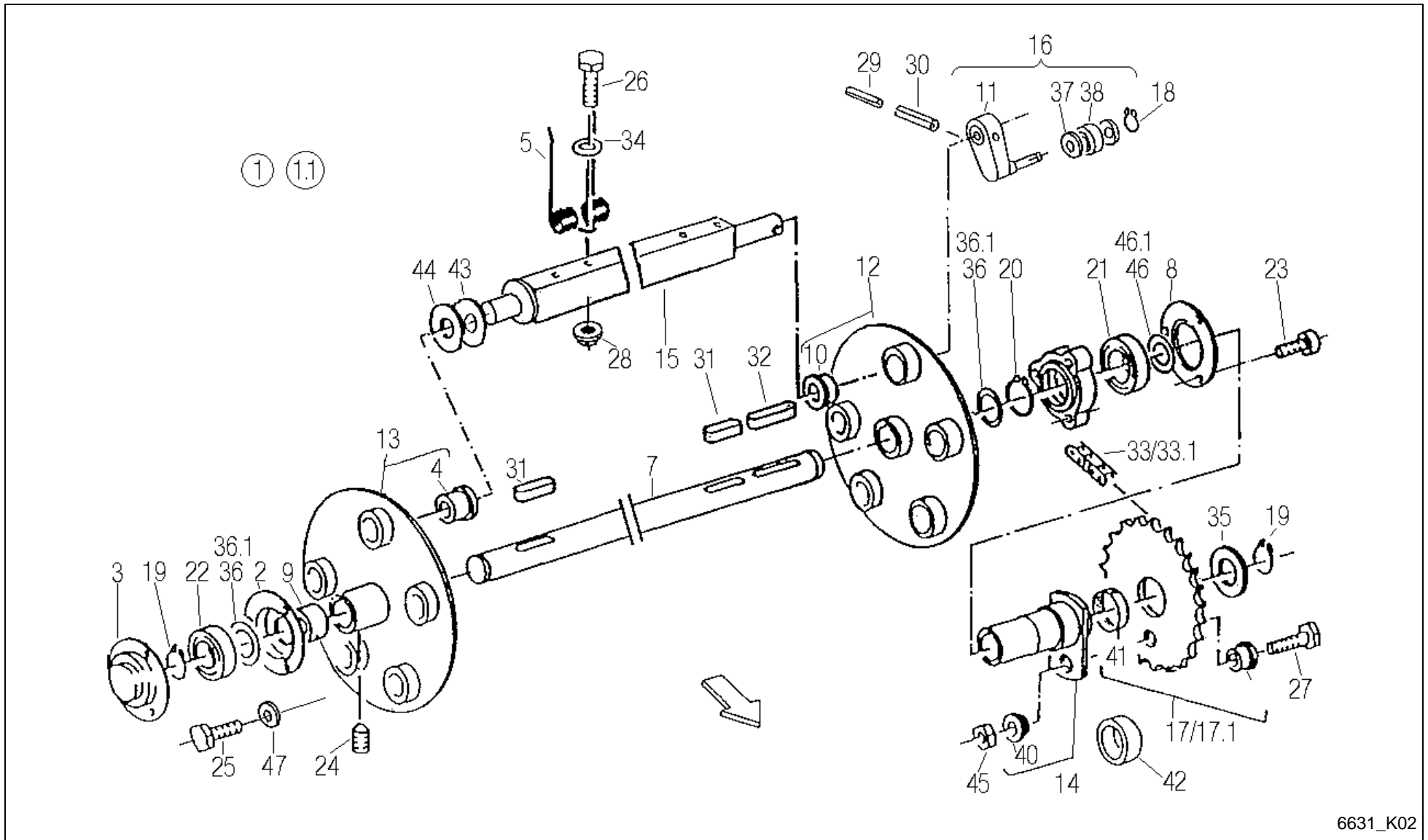

6631_K02

FeedMaster 3600T / PICK-UP 1.6 DRUM



PosNo.	Part No.	Qty.	Description	Remark
1	VF16513250	1	PICK-UP	-540
1.1	VF16630125	1	PICK-UP 5 REEL	+541
2	VF06282196	1	TERMINAL RING	
3	VF06301830	1	TERMINAL RING	
4	VF06246795	5	BUSH	
5	VF06296285	65	PICK-UP TINE, TWIN	
6	VF06577397	1	FLANGE	
7	VF06571004	1	DRIVE SHAFT	
8	VF06577406	1	COVER	
9	VF06577407	1	SPACER RING	
10	VF06571309	5	BUSH	
11	VF06571321	5	PIN	
12	VF16513298	1	ROSETTE	
13	VF16513299	1	ROSETTE	
14	VF06559244	1	FLANGED HUB	
15	VF16613400	5	TUBE	
16	VF16615203	5	CONTROL ARM	
17	VF16630156	1	CHAIN SPROCKET Z=34	-A 2005
17.1	VF06577432	1	CHAIN SPROCKET	+A 2006
18	VF01107726	5	CIRCLIP	
19	VF01107742	2	CIRCLIP	
20	VF01107760	1	CIRCLIP	
21	VF01108982	1	GR.BALL BEARING	
22	VF01136763	1	GR. BALL BEARING	
23	VF02953340	3	BOLT M8X50 D912 DIN267-27 COATED	
24	VF06208913	2	ALLEN SET SCREW, INT. HEX.	
25	VF01173381	3	SCR.M8X20 D933 8.8 GALV.DIN267-27MKL	
26	VF01111184	65	HEX.BOLT	
27	VF16630966	1	SHEAR SCREW	
28	VF01397863	65	WHEEL NUT M8 D6926 8 GALV.	
29	VF01157348	5	DOWEL PIN	
30	VF01157382	5	ROLL PIN 10X65 EN ISO 8752 ZN.FL.	
31	VF06212426	2	FITTING KEY	
32	VF06212435	1	FITTING KEY	
33	VF16630139	1	CHAIN 19.05-12B-1X87GL. D8187	bei Pos.17
33.1	A143015000	1	CHAIN 12B-1VX86E INCL. VGL	bei Pos.17.1
34	VF01138374	65	WASHER	
35	VF06214420	1	DISC	
36	VF06214481		SPACER 30X42X1 DIN988	
36.1	VF01138686		SPACER 30X42X0,5 DIN988	

FeedMaster 3600T / PICK-UP 1.6 DRUM

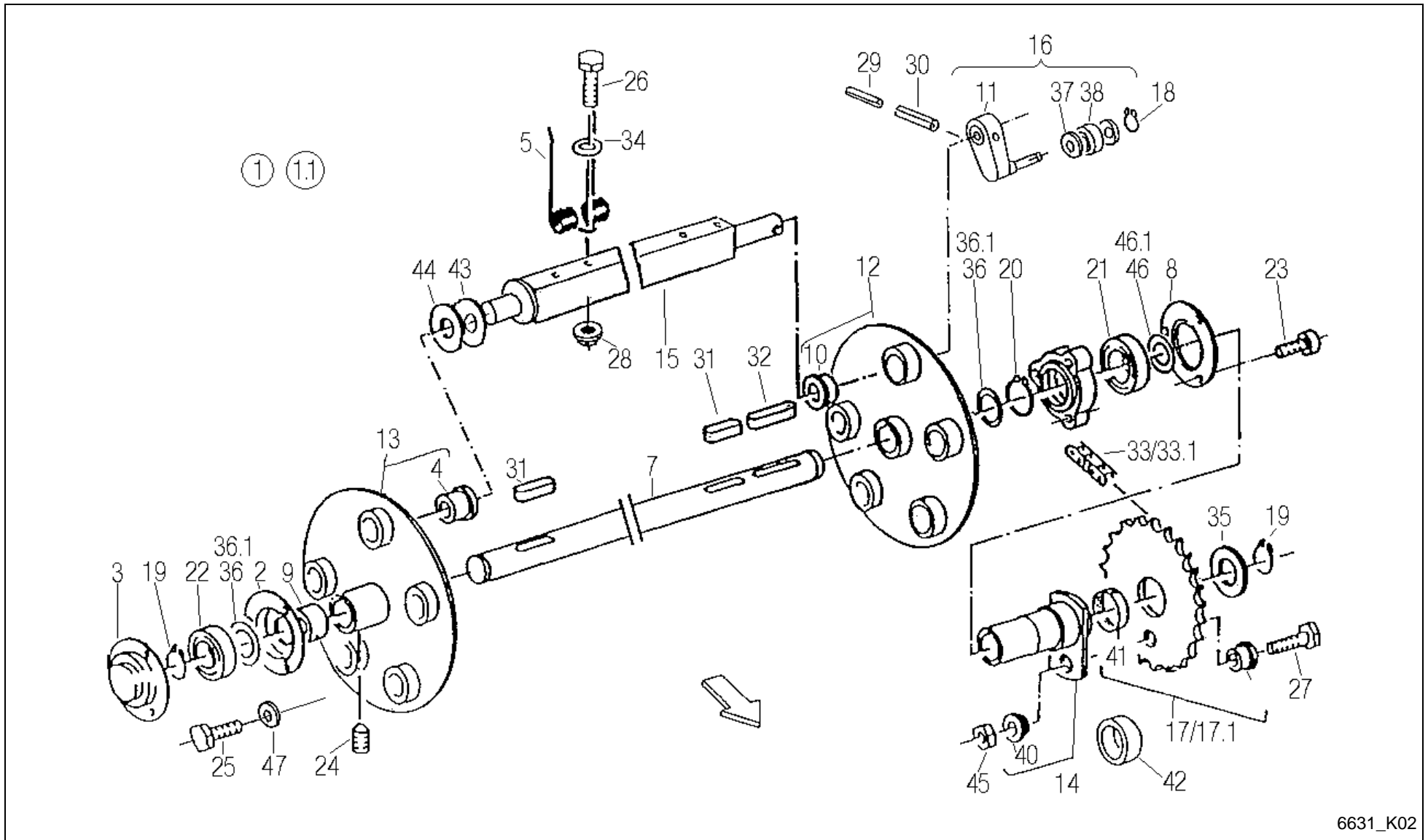

6631_K02

FeedMaster 3600T / PICK-UP 1.6 DRUM



PosNo.	Part No.	Qty.	Description	Remark
37	VF06214938	10	NILOSRING 6303 ZAV	
38	VF06215027	5	LAUFROLLE LR 203NPPU 17X47X12	
40	VF06571314	2	BUSH	
41	VF06277516	1	BEARING BUSH	
42	VF06571148	1	PIPE/TUBE	
43	VF06214314	5	WASHER 26X38X1 GALV.	
44	VF06214313	5	WASHER 26X38X2 GALV.	
45	VF01104944	1	NY LOCK NUT 8A3CD985	
46	VF06214570		SPACER	
46.1	VF06214572		SPACER 45X55X0,5	
47	VF16631181	3	WASHER A8	

FeedMaster 3600T / PICK-UP 1.6 BAFFLE PLATE

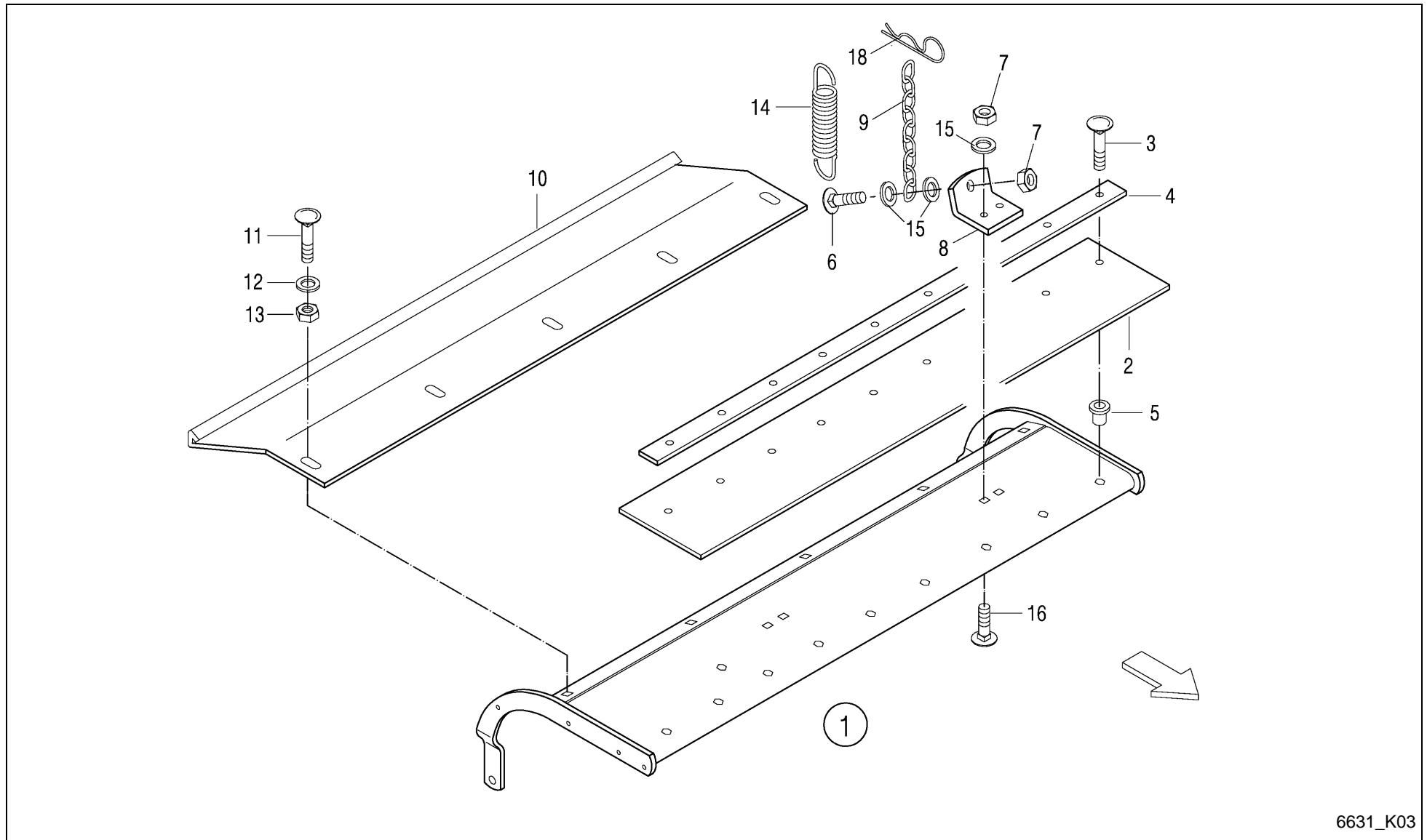

6631_K03

FeedMaster 3600T / PICK-UP 1.6 BAFFLE PLATE



PosNo.	Part No.	Qty.	Description	Remark
1	VF16611487	1	BAFFELE-PLATE	
2	VF16611479	1	RUBBER BAR	X 1
3	VF01142806	9	TRUSS-HEAD SCREW	X 1
4	VF06578934	1	STRIP	X 1
5	VF01142805	9	RIVET NUT	X 1
6	VF01137628	2	SAUCER HEAD SCREW	
7	VF01104944	6	NY LOCK NUT 8A3CD985	X 1
8	VF16513473	2	RETAINER	X 1
9	VF01397609	2	CHAIN/TRACK	
10	VF06577423	1	EXTENSION	
11	VF06207535	5	OVAL HEADED BOLT	
12	VF01107165	5	WASHER M10 11X20X2 A2C DIN126	
13	VF01104944	5	NY LOCK NUT 8A3CD985	
14	VF01397931	2	DRAW SPRING	
15	VF01127538	4	WASHER	
16	VF01108524	4	SCREW	X 1
18	VF06215666	2	SPRING CLIP	

FeedMaster 3600T / PICK-UP 1.6 TACTILE WHEEL PNEUMATIC TIRE

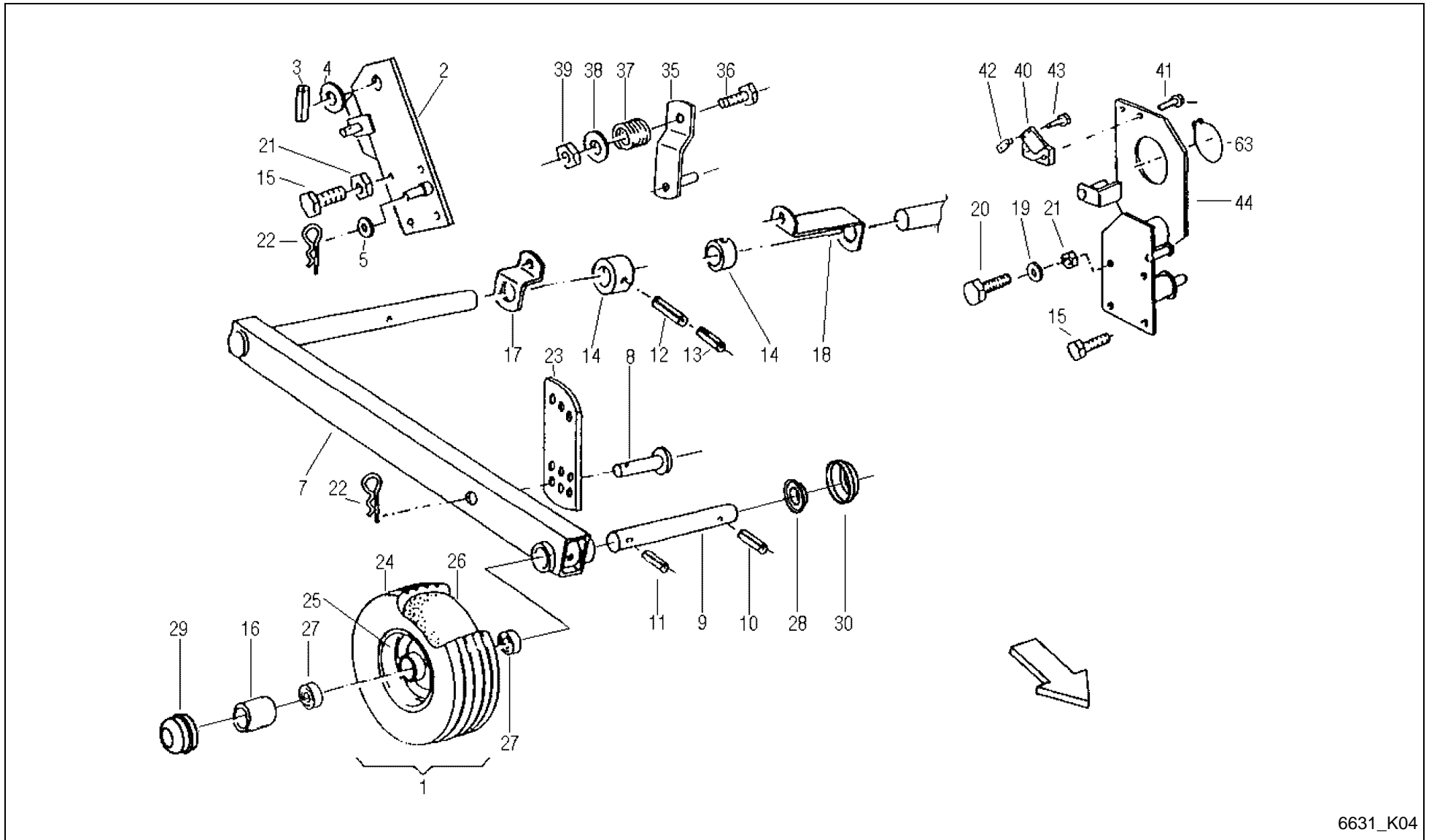

6631_K04

FeedMaster 3600T / PICK-UP 1.6 TACTILE WHEEL PNEUMATIC TIRE



PosNo.	Part No.	Qty.	Description	Remark
1	VF06564733	2	CPL. WHEEL 15X6.0-6 TT 6PR SILVER RIM	
2	VF16630109	1	RETAINER RIGHT	
3	VF01115460	1	COLLET CHUCK	
4	VF06214234	1	WASHER 31X45X2 GALV.	
5	VF06214226	1	WASHER	
7	VF16517499	2	AXLE LINK	
8	VF06210033	2	PIN	
9	VF16514201	2	PIN/BOLT/STUD	
10	VF01115457	2	DOWEL PIN	
11	VF01157344	1	DOWEL PIN	
12	VF01123863	1	DOWEL PIN	
13	VF01157338	2	DOWEL PIN	
14	VF06577422	2	RING	
15	VF01173914	4	SCR. M10X25D933 8.8 GALV. DIN267-27	
16	VF06576830	2	PIPE	
17	VF06577421	1	SUPPORT	
18	VF06577420	1	SUPPORT	
19	VF01127538	2	WASHER	
20	VF01112429	4	HEX. HEAD SCREW	
21	VF06209768	4	LOCK NUT	
22	VF06215666	4	SPRING CLIP	
23	VF06556744	2	ARM	
24	VF01141364	2	TIRE 15X6.00-6 6PR TT C737	
25	VF06564735	2	RIM 4.50 AX6 SILVER	
26	VF01141365	2	INNER TUBE 15X6,00X6 TR13	
27	VF01124703	4	BEARING	
28	VF06567492	1	BUSH D25+31,5 L13,5	
29	VF06567493	2	WHEEL CAP D 52 H = 36 MM	
30	VF16622598	1	ANTI WRAPPING DEVICE MEFRO 15"+16" ZN	
35	VF06558198	1	LEVER	
36	VF01111298	1	HEX. HEAD SCREW	
37	VF06215308	1	COMPRESSION SPRING	
38	VF01107165	1	WASHER M10 11X20X2 A2C DIN126	
39	VF06209768	1	LOCK NUT	
40	VF06577387	1	GRAPHITE RING	
41	VF06277504	2	HEX. HEAD SCREW	
42	VF06587560	1	SLIDE PIECE	
43	VF01112333	2	HEX. HEAD SCREW	
44	VF16630106	1	SUPPORT	
63	VF01107792	1	CIRCLIP	

FeedMaster 3600T / PICK-UP 1.6 BAFFLE PLATE WITH ROLE

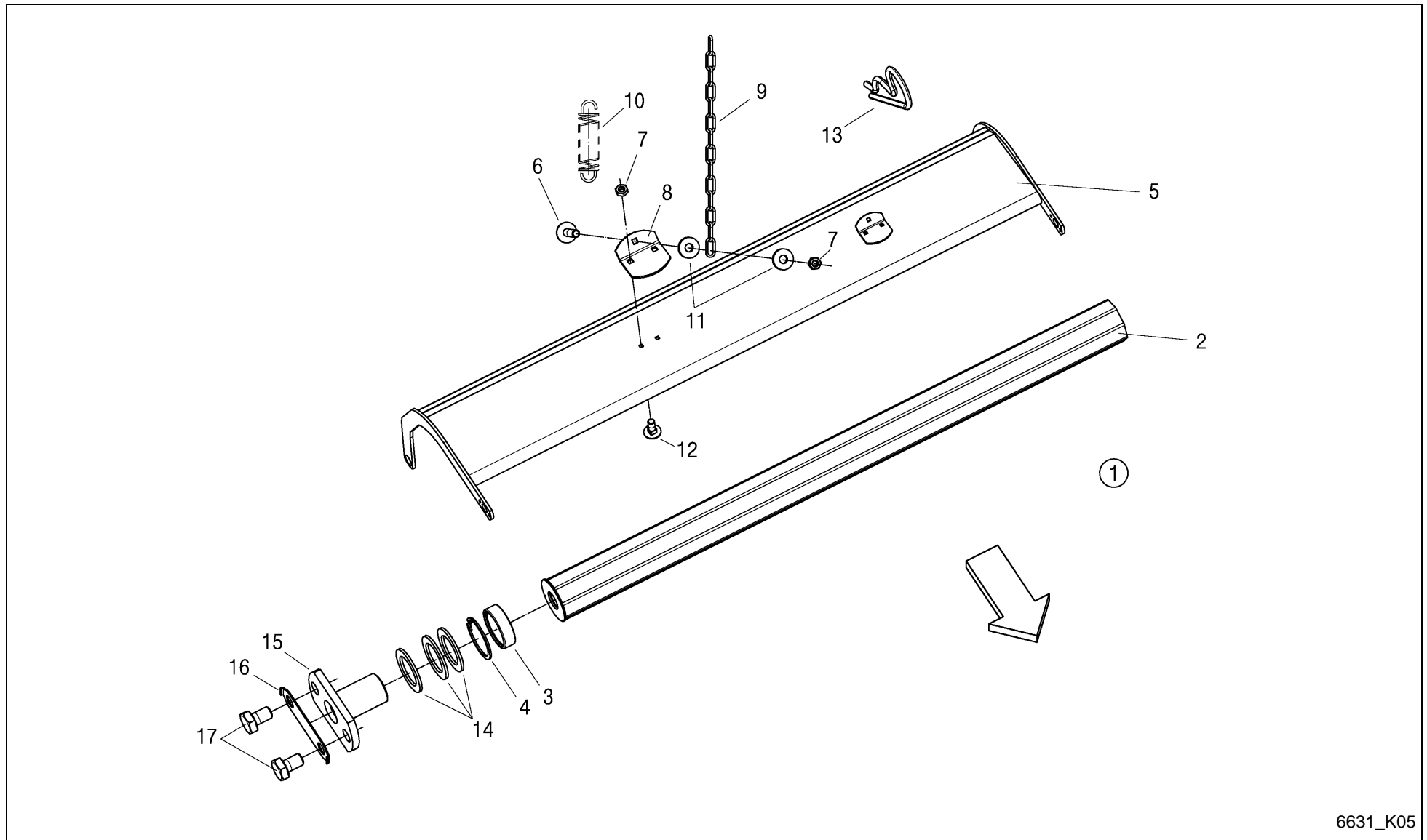

6631_K05

FeedMaster 3600T / PICK-UP 1.6 BAFFLE PLATE WITH ROLE



PosNo.	Part No.	Qty.	Description	Remark
1	VF16631430	1	BAFFLE PLATE WITH ROLE	
2	VF16631427	1	ROLE PREASSEMBLED	inkl. Pos.3+4
3	VF01136762	2	BEARING	
4	VF01107838	2	CIRCLIP	
5	VF16631429	1	BAFFLE PLATE	
6	VF01137628	2	SAUCER HEAD SCREW	
7	VF01104944	6	NY LOCK NUT 8A3CD985	
8	VF16513473	2	RETAINER	
9	VF01397609	2	CHAIN/TRACK	
10	VF01397931	2	DRAW SPRING	
11	VF01127538	4	WASHER	
12	VF01108524	4	SCREW	
13	VF06215666	2	SPRING CLIP	
14	VF06214313	12	WASHER 26X38X2 GALV.	
15	VF16631126	2	BOLT WELDED	
16	VF16631133	2	SAFETY PLATE	
17	VF01178250	4	HEX. HEAD SCREW	

FeedMaster 3600T / PICK-UP 1.8 DRUM

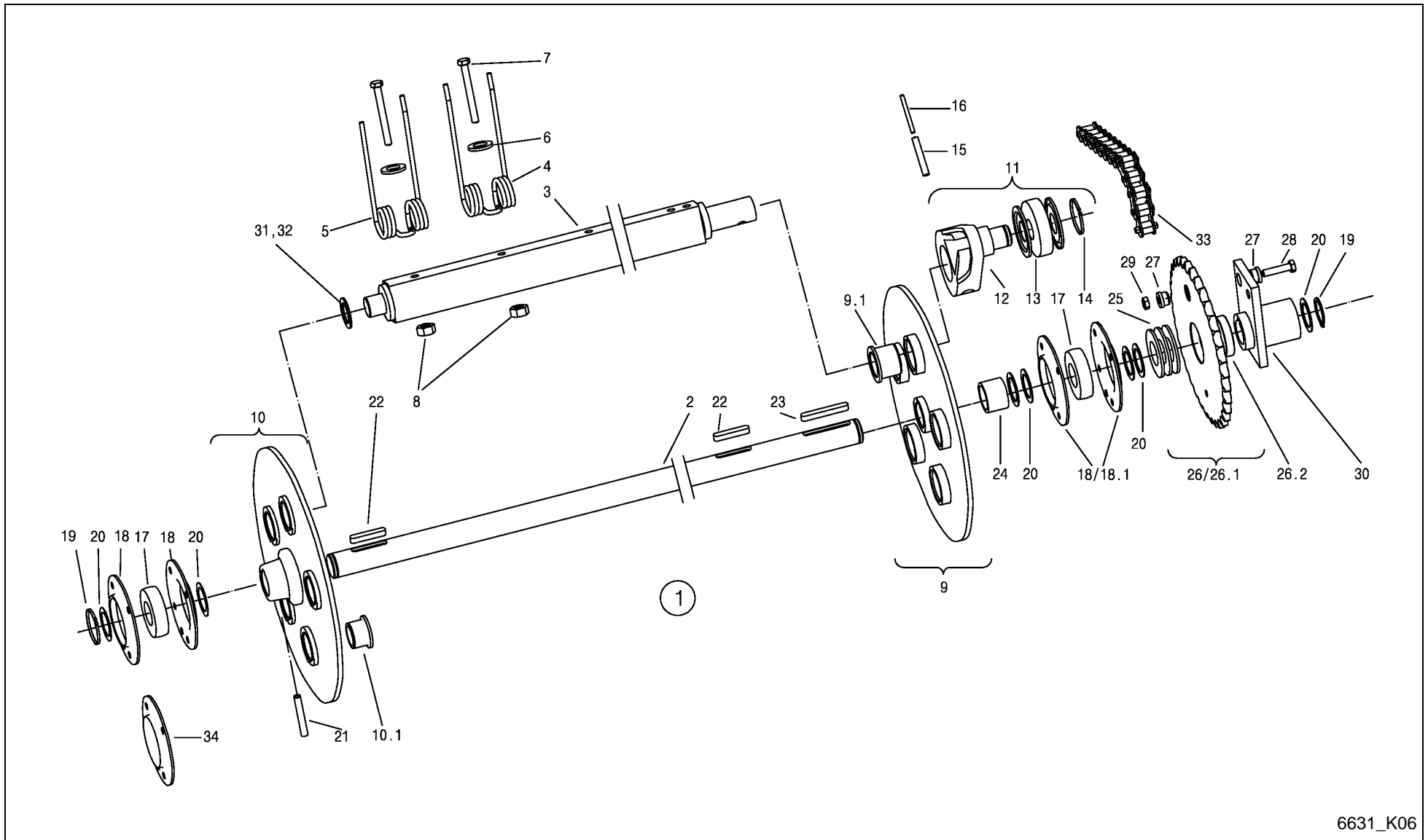

6631_K06

FeedMaster 3600T / PICK-UP 1.8 DRUM



PosNo.	Part No.	Qty.	Description	Remark
1	VF16630740	1	PICK-UP 1.8	
2	VF16630685	1	DRIVE SHAFT	
3	VF16630682	5	TUBE WELDED	
4	VF06296285	65	PICK-UP TINE, TWIN	+A 2004 - 70St.
5	VF16630684	5	REEL TINE	+A 2004 - 0St.
6	VF01138374	70	WASHER	
7	VF01111184	70	HEX.BOLT	
8	VF01397863	70	WHEEL NUT M8 D6926 8 GALV.	
9	VF16513298	1	ROSETTE	
9.1	VF06571309	5	BUSH	
10	VF16513299	1	ROSETTE	
10.1	VF06246795	5	BUSH	
11	VF16615203	5	CONTROL ARM	
12	VF16615205	5	CONTROL LEVER	
13	VF06215027	5	LAUFROLLE LR 203NPPU 17X47X12	
14	VF01107726	5	CIRCLIP	
15	VF01157382	5	ROLL PIN 10X65 EN ISO 8752 ZN.FL.	
16	VF01157348	5	DOWEL PIN	
17	VF16630709	2	FLANGED SLEEVE 1726206 2RS	
18	VF16630686	2	SHEET METAL CASE 2-PIECE	+A 2004 - 1St.
18.1	VF16631187	1	BEARING FLANGE 2-PIECE	+A 2004 mit 21.1 K08
19	VF01107742	2	CIRCLIP	
20	VF06214481	10	SPACER 30X42X1 DIN988	+A 2004 mit 18.1- 15St.
21	VF06208913	2	ALLEN SET SCREW, INT. HEX.	
22	VF06212426	2	FITTING KEY	
23	VF16630743	1	FITTING KEY A8X7X60	
24	VF16630766	1	SPACER RING	
25	VF06214420	3	DISC	+A 2004 mit 18.1- 15St.
26	VF16630156	1	CHAIN SPROCKET Z=34	für 6R -A 2005
26.1	VF06577432	1	CHAIN SPROCKET	für 4R +A 2006 a. für 6R
26.2	VF06277516	1	BEARING BUSH	
27	VF06571314	2	BUSH	
28	VF16630966	1	SHEAR SCREW	
29	VF01104944	1	NY LOCK NUT 8A3CD985	
30	VF16630744	1	FLANGED HUB	
31	VF06214314	5	WASHER 26X38X1 GALV.	
32	VF06214313	5	WASHER 26X38X2 GALV.	
33	VF16630768.01	1	CHAIN 12B-1VX90E	für 6R -A 2006
33	VF16630767.01	1	CHAIN 12B-1VX89L	für 4R +A 2006 für alle
34	VF16631868	1	COVER	V; +A 2012-Serie

FeedMaster 3600T / PICK-UP 1.8 DRUM (+A 2004)

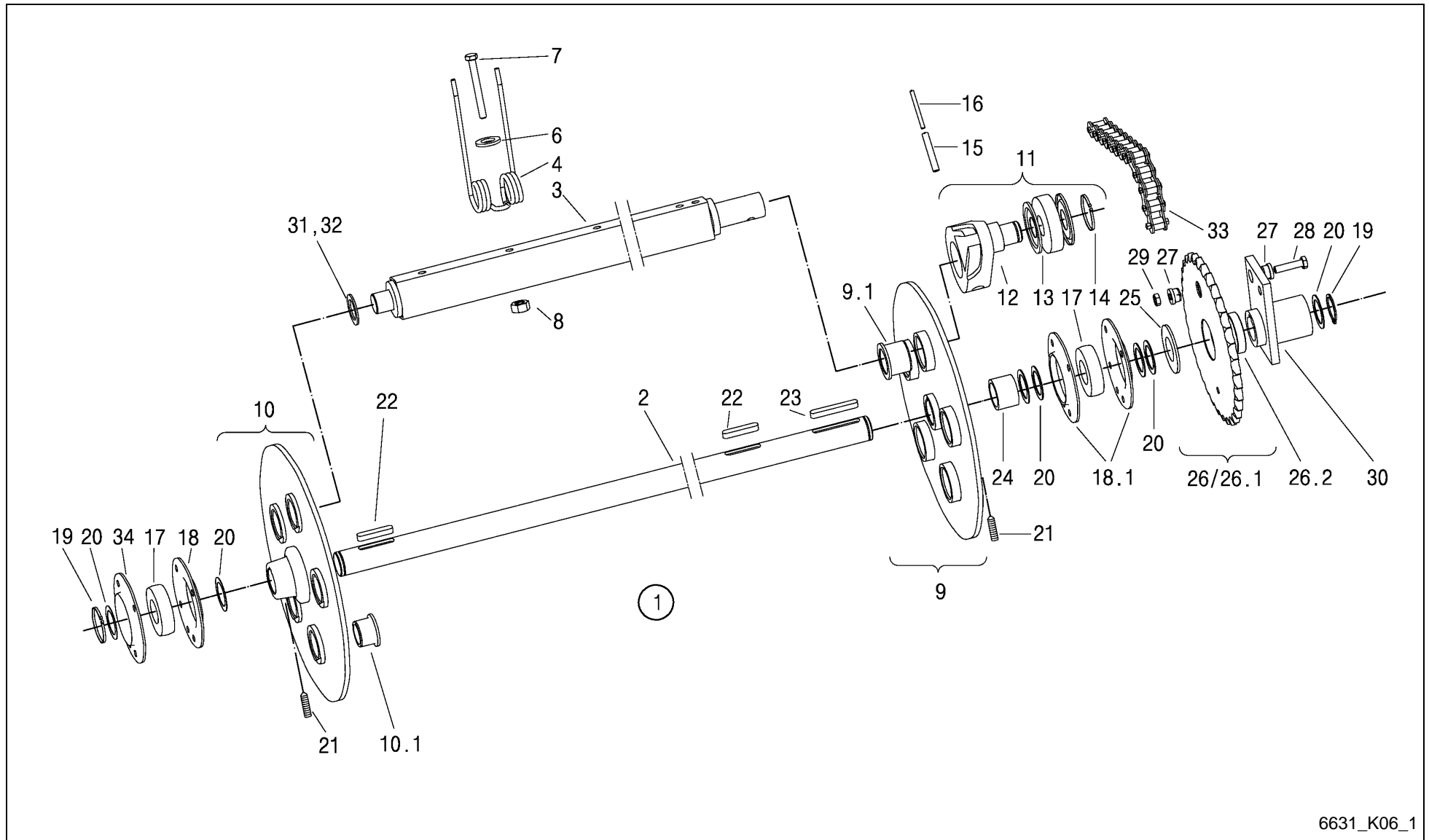

6631_K06_1

FeedMaster 3600T / PICK-UP 1.8 DRUM (+A 2004)



PosNo.	Part No.	Qty.	Description	Remark
1	A143030430	1	PICK-UP 1.8 ASSEMBLED	
2	VF16630685	1	DRIVE SHAFT	
3	VF16630682	5	TUBE WELDED	
4	VF06296285	70	PICK-UP TINE, TWIN	
6	VF01138374	70	WASHER	
7	VF01111184	70	HEX.BOLT	
8	VF01397863	70	WHEEL NUT M8 D6926 8 GALV.	
9	VF16513298	1	ROSETTE	
9.1	VF06571309	5	BUSH	
10	VF16513299	1	ROSETTE	
10.1	VF06246795	5	BUSH	
11	VF16615203	5	CONTROL ARM	
12	VF16618715	5	LEVER	
13	VF06215027	5	LAUFROLLE LR 203NPPU 17X47X12	
14	VF01107726	5	CIRCLIP	
15	VF01157382	5	ROLL PIN 10X65 EN ISO 8752 ZN.FL.	
16	VF01157348	5	DOWEL PIN	
17	VF16630709	2	FLANGED SLEEVE 1726206 2RS	
18	VF16630686	0.5000	SHEET METAL CASE 2-PIECE	
18.1	VF16631187	1	BEARING FLANGE 2-PIECE	2x VF16630769
19	VF01107742	2	CIRCLIP	
20	VF06214481	20	SPACER 30X42X1 DIN988	
21	VF06208913	2	ALLEN SET SCREW, INT. HEX.	
22	VF06212426	2	FITTING KEY	
23	VF16630743	1	FITTING KEY A8X7X60	
24	VF16630766	1	SPACER RING	
25	VF06214420	1	DISC	
26	VF16630156	1	CHAIN SPROCKET Z=34	-A 2005 für 6R
26.1	VF06577432	1	CHAIN SPROCKET	für 4R; +A 2006 auch für 6R
26.2	VF06277516	1	BEARING BUSH	
27	VF06571314	2	BUSH	
28	VF16630966	1	SHEAR SCREW	
29	VF01104944	1	NY LOCK NUT 8A3CD985	
30	VF16630744	1	FLANGED HUB	
31	VF06214314	5	WASHER 26X38X1 GALV.	
32	VF06214313	5	WASHER 26X38X2 GALV.	
33	VF16630768.01	1	CHAIN 12B-1VX90E	-A 2005 für 6R
33	VF16630767.01	1	CHAIN 12B-1VX89L	+A 2006
34	VF16631868	1	COVER	

FeedMaster 3600T / PICK-UP BAFFLE-PLATE

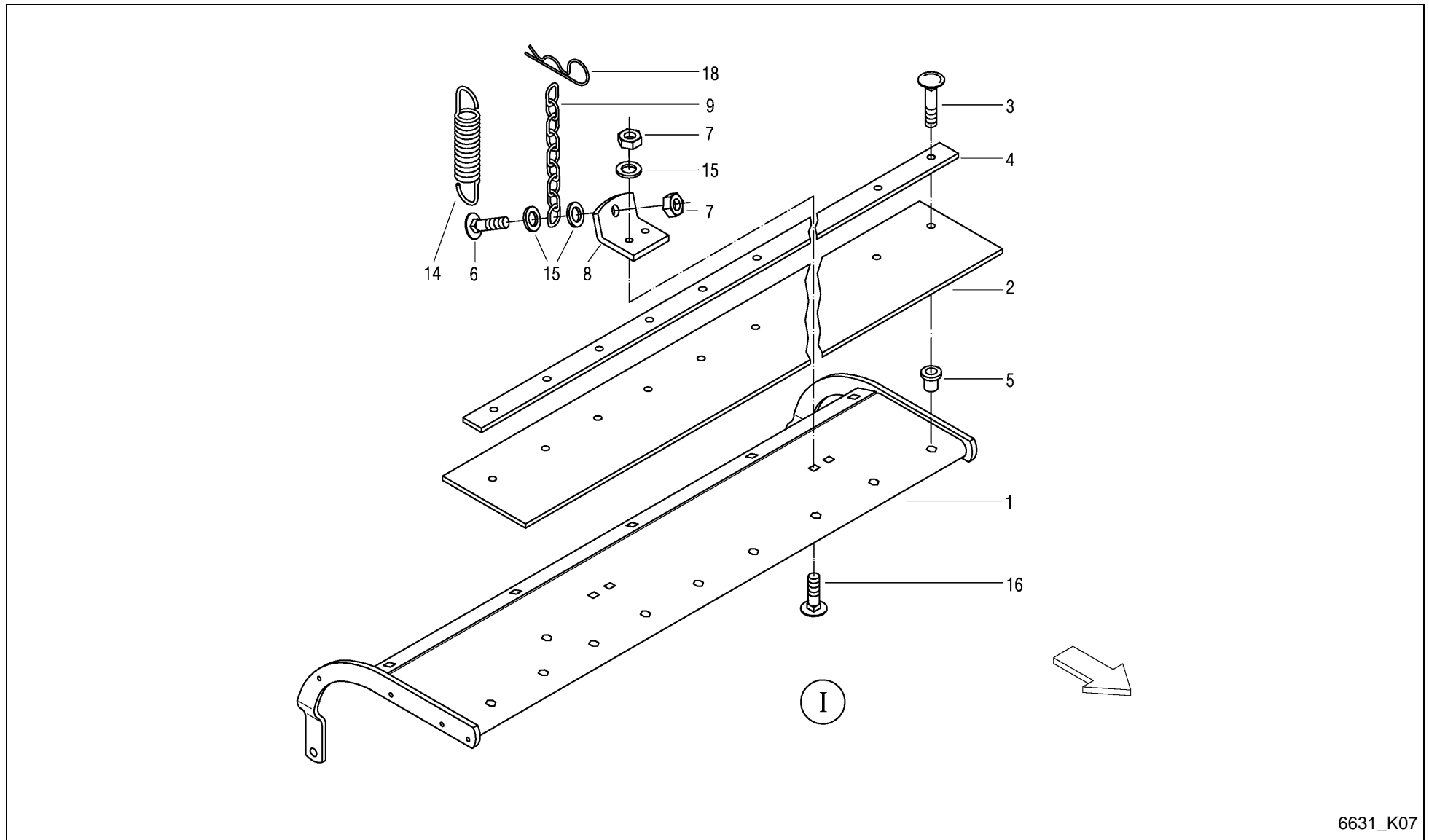

6631_K07

FeedMaster 3600T / PICK-UP BAFFLE-PLATE



PosNo.	Part No.	Qty.	Description	Remark
1	VF16630737	1	BAFFLE PLATE	
1	VF16630730	1	BAFFLE PLATE PU 1.8	X I
2	VF16611479	1	RUBBER BAR	X I
3	VF01142806	9	TRUSS-HEAD SCREW	X I
4	VF06578934	1	STRIP	X I
5	VF01142805	9	RIVET NUT	X I
6	VF01137628	2	SAUCER HEAD SCREW	
7	VF01104944	6	NY LOCK NUT 8A3CD985	X I
8	VF16513473	2	RETAINER	X I
9	VF01397609	2	CHAIN/TRACK	
14	VF01397931	2	DRAW SPRING	
15	VF01127538	4	WASHER	
16	VF01108524	4	SCREW	X I
18	VF06215666	2	SPRING CLIP	

FeedMaster 3600T / PICK-UP SCAPPER

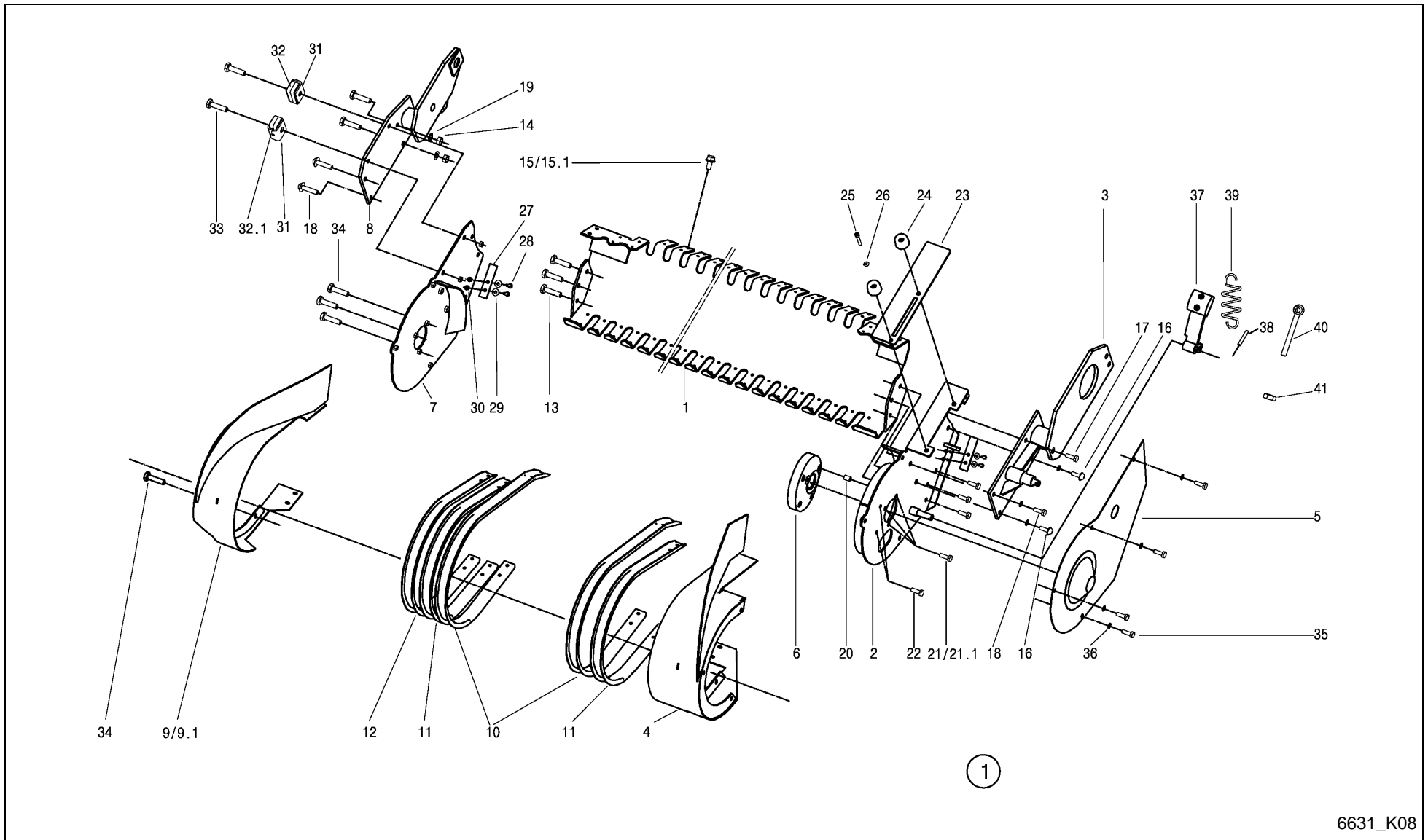

6631_K08

FeedMaster 3600T / PICK-UP SCAPPER



PosNo.	Part No.	Qty.	Description	Remark
1	VF16630705	1	SUPPORT	
2	VF16630695	1	SIDE MEMBER LEFT	
3	VF16630690	1	SUPPORT LEFT	
4	VF16630716	1	COVERING LEFT WELDED	
5	VF16630738	1	GUARD PLATE	
6	VF06296264	1	STEERING PLATE	
7	VF16630700	1	SIDE MEMBER RIGHT	
8	VF16630710	1	SUPPORT RIGHT WELDED	
9	VF16630736	1	COVERING	
9.1	VF16630736.01	1	COVERING PU 1,8	+A 2004
10	VF16630706	24	SHEET	
11	VF16630707	2	SHEET OUTSIDE	
12	VF16630746	1	SHEET SHORT	
13	VF01112418	6	BOLT, SCREW	
14	VF06209768	4	LOCK NUT	
15	VF06273854	114	HEX. HEAD SCREW	
15.1	VF0905191000	114	GEWINDEFURCHSCHRAUBE M 6 X 16	E Pos.15 +A 2009 Serie
16	VF01142213	22	TRUSS-HEAD SCREW	
17	VF01112429	3	HEX. HEAD SCREW	
18	VF01173914	3	SCR. M10X25D933 8.8 GALV. DIN267-27	
19	VF01127538	4	WASHER	
20	VF16614668	3	PIN, TENSION	
21	VF01111136	3	VIS	
21.1	VF16631186	3	BOLT M8X45 D933 8.8	+A 2004 mit Pos 18.1/K06
22	VF06209476	2	BOLT M8X30 D933 8.8 A3C DIN267-27 COATE	
23	VF16630721	1	CRANK PU 1,8	
24	VF01141112	2	RUBBER PAD	
25	VF16630742	2	SCREW M8X35 DIN912 8.8	
26	VF01107163	2	WASHER	
27	VF16630734	2	RUBBER SHEET	
28	VF01112264	4	HEX. HEAD SCREW	
29	VF06214189	4	WASHER 6,4X18X2 A2C	
30	VF01114357	4	LOCK NUT	
31	VF06571322	2	YOKE	
32	VF06571323	4	STOP	
32.1	VF16635132	1	LIMIT STOP	+A 2012 Serie
33	VF01112451	2	HEX. HEAD SCREW	
34	VF01173381	9	SCR.M8X20 D933 8.8 GALV.DIN267-27MKL	
35	VF01112307	4	HEX. HEAD SCREW	
36	VF16631181	4	WASHER A8	

FeedMaster 3600T / PICK-UP SCAPPER

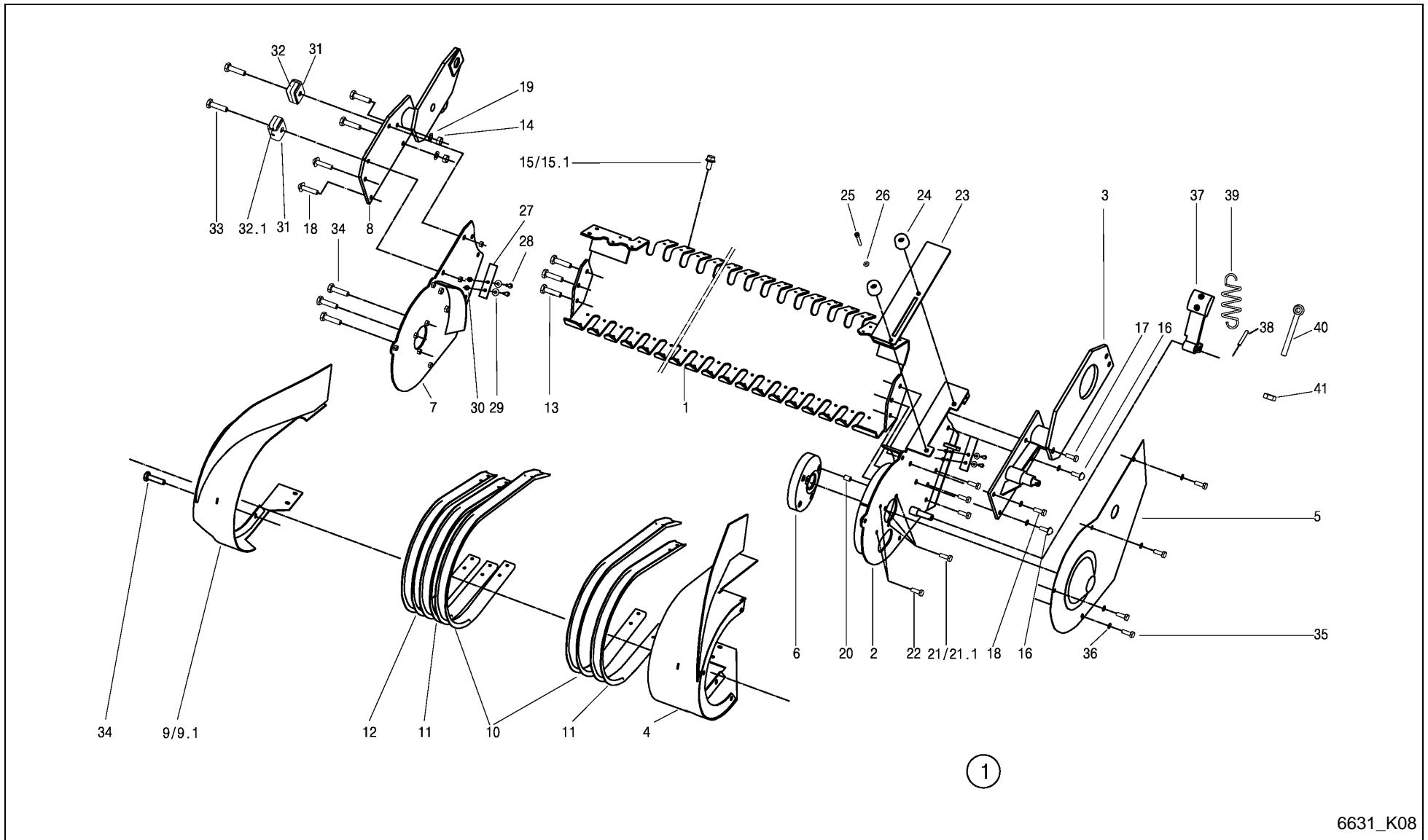

6631_K08

FeedMaster 3600T / PICK-UP SCAPPER



PosNo.	Part No.	Qty.	Description	Remark
37	VF16630745	1	TENSIONER	
38	VF01115441	1	DOWEL PIN	
39	VF06215561	1	TENSION SPRING	
40	VF01138951	1	EYE BOLT LBM 8X 50 DIN 444 - 4.6	
41	VF01112824	2	HEX. NUT	

FeedMaster 3600T / PICK-UP 1.8 TACTILE WHEEL PNEUMATIC TIRE

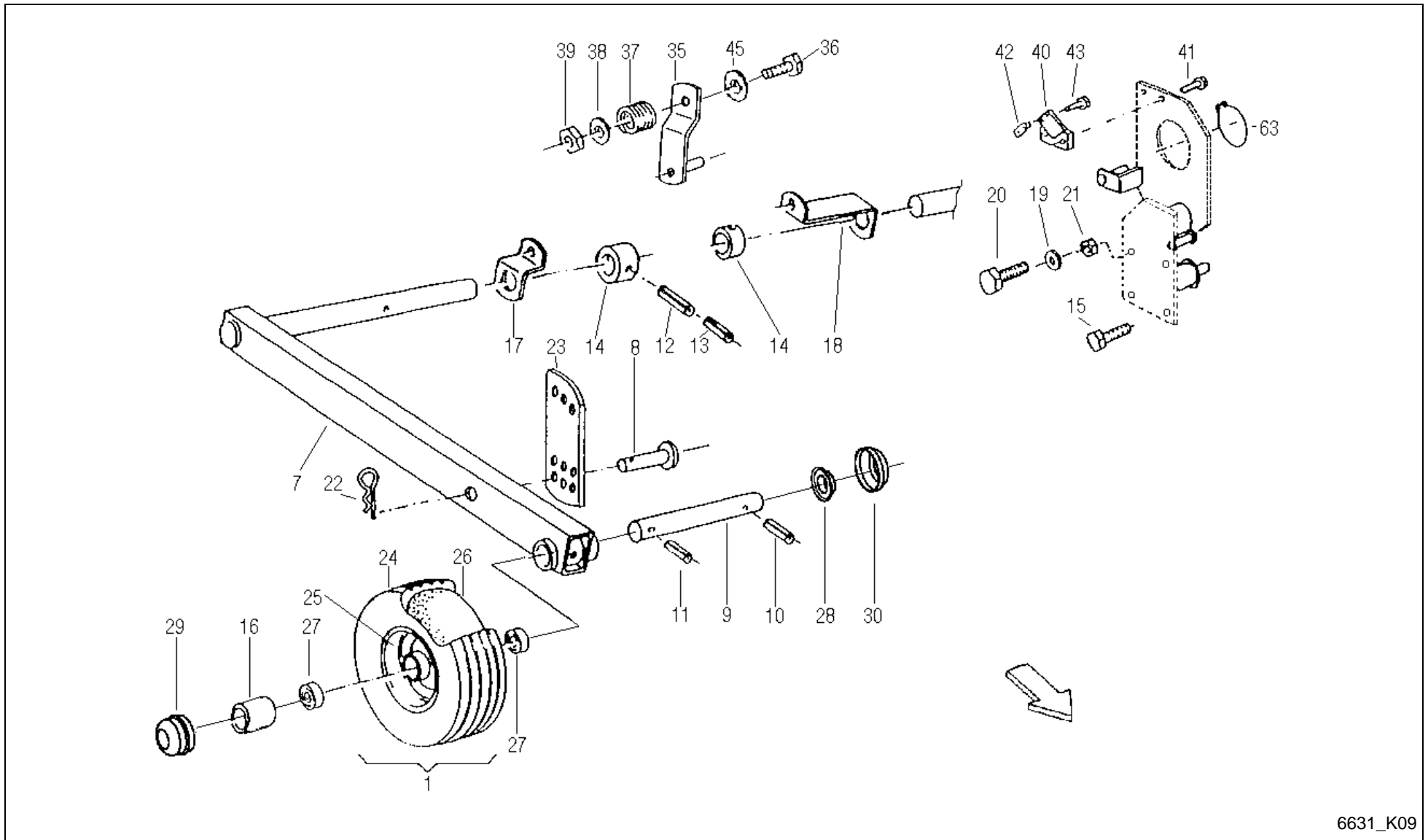

6631_K09

FeedMaster 3600T / PICK-UP 1.8 TACTILE WHEEL PNEUMATIC TIRE



PosNo.	Part No.	Qty.	Description	Remark
1	VF06564733	2	CPL. WHEEL 15X6.0-6 TT 6PR SILVER RIM	
7	VF16517499	2	AXLE LINK	
8	VF06210033	2	PIN	
9	VF16514201	2	PIN/BOLT/STUD	
10	VF01115457	2	DOWEL PIN	
11	VF01157344	2	DOWEL PIN	
12	VF01123863	2	DOWEL PIN	
13	VF01157338	2	DOWEL PIN	
14	VF06577422	2	RING	
15	VF01173914	4	SCR. M10X25D933 8.8 GALV. DIN267-27	
16	VF06576830	2	PIPE	
17	VF06577421	1	SUPPORT	
18	VF06577420	1	SUPPORT	
19	VF01127538	2	WASHER	
20	VF01112429	4	HEX. HEAD SCREW	
21	VF06209768	4	LOCK NUT	
22	VF06215666	4	SPRING CLIP	
23	VF06556744	2	ARM	
24	VF01141364	2	TIRE 15X6.00-6 6PR TT C737	
25	VF06564735	2	RIM 4.50 AX6 SILVER	
26	VF01141365	2	INNER TUBE 15X6,00X6 TR13	
27	VF01124703	4	BEARING	
28	VF01167577	4	ND 6198	
29	VF06580546	2	CAP	
30	VF06567492	2	BUSH D25+31,5 L13,5	
35	VF06558198	1	LEVER	
36	VF01111315	1	HEX.HEAD SCREW	
37	VF06215308	1	COMPRESSION SPRING	
38	VF01107165	1	WASHER M10 11X20X2 A2C DIN126	
39	VF06209768	1	LOCK NUT	
40	VF06577387	1	GRAPHITE RING	
41	VF06277504	2	HEX. HEAD SCREW	
42	VF06587560	1	SLIDE PIECE	
43	VF01112333	2	HEX. HEAD SCREW	
45	KG01273861	1	WASHER DIN7349 M14 A3C	
63	VF01107792	1	CIRCLIP	

FeedMaster 3600T / PICK-UP 1.8 BAFFLE PLATE WITH ROLE

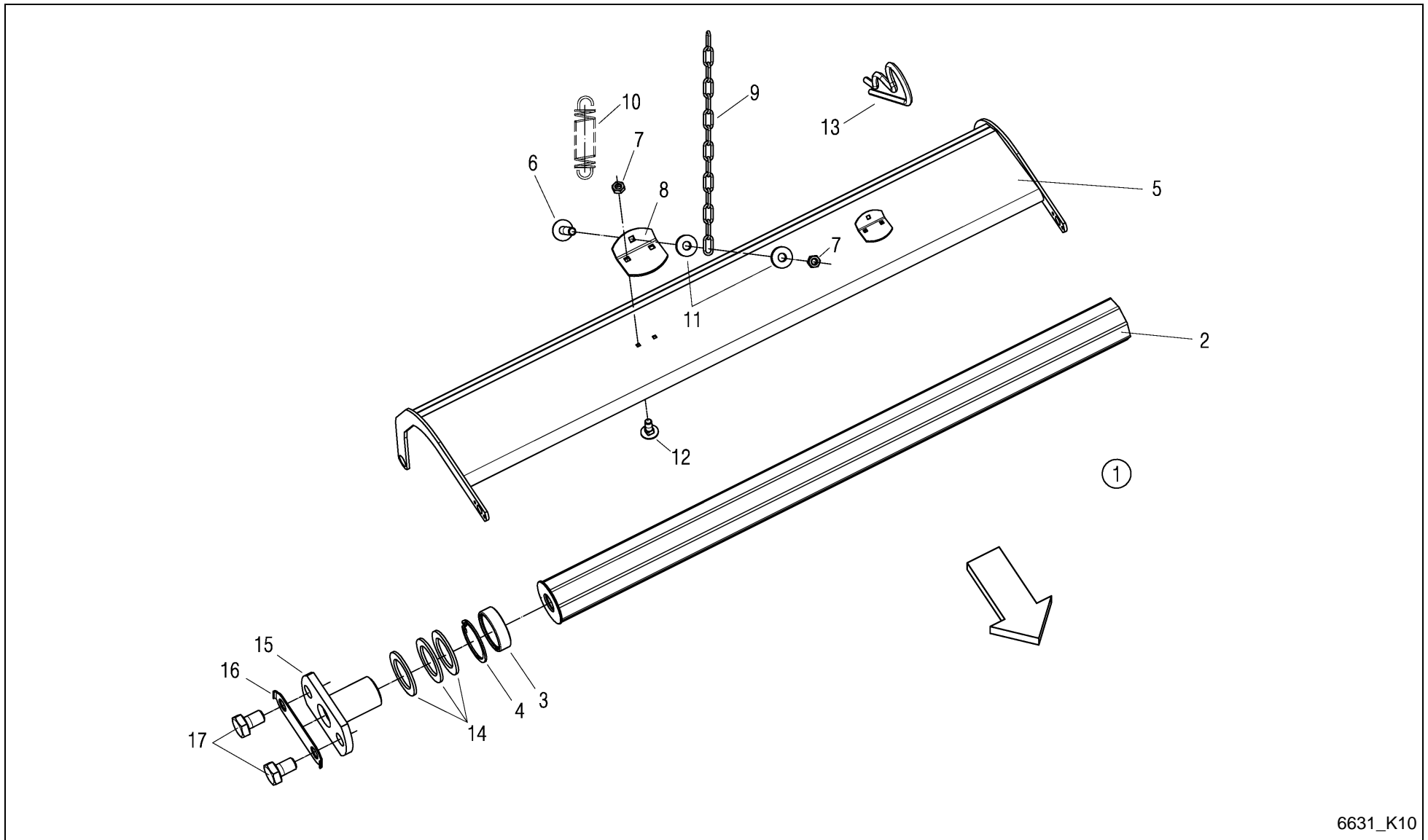

6631_K10

FeedMaster 3600T / PICK-UP 1.8 BAFFLE PLATE WITH ROLE



PosNo.	Part No.	Qty.	Description	Remark
1	VF16631135	1	BAFFLE PLATE WITH ROLE	
2	VF16631134	1	ROLE PREASSEMBLED	inkl. Pos.3+4
3	VF01136762	2	BEARING	
4	VF01107838	2	CIRCLIP	
5	VF16631129	1	BAFFLE PLATE WELDED	
6	VF01137628	2	SAUCER HEAD SCREW	
7	VF01104944	6	NY LOCK NUT 8A3CD985	
8	VF16513473	2	RETAINER	
9	VF01397609	2	CHAIN/TRACK	
10	VF01397931	2	DRAW SPRING	
11	VF01127538	4	WASHER	
12	VF01108524	4	SCREW	
13	VF06215666	2	SPRING CLIP	
14	VF06214313	12	WASHER 26X38X2 GALV.	
15	VF16631126	2	BOLT WELDED	
16	VF16631133	2	SAFETY PLATE	
17	VF01178250	4	HEX. HEAD SCREW	

FeedMaster 3600T / SCRAPER FLOOR BOARDS

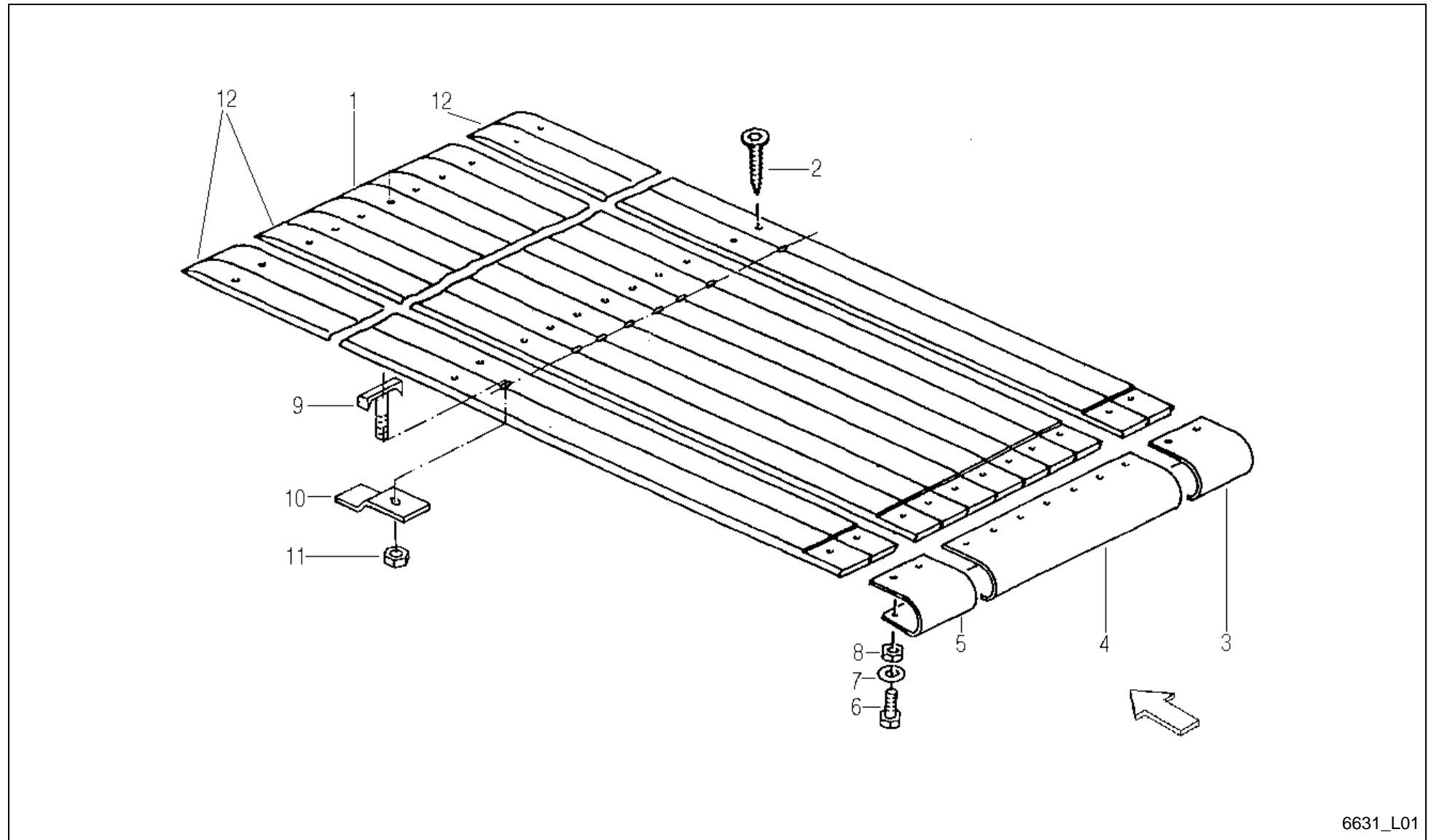

6631_L01

FeedMaster 3600T / SCRAPER FLOOR BOARDS



PosNo.	Part No.	Qty.	Description	Remark
1	VF06570925	8	PLANK/BOARD	
2	VF01142958	42	SELF-DRILLING SCREW 8X65 SCT 10/35 ZN	
3	VF16515750	1	COVER PLATE, RH	
4	VF16515748	1	COVER PLATE	
5	VF16515749	1	COVER PLATE, LH	
6	VF01112322	5	HEX. HEAD SCREW	
7	VF06214193	5	WASHER 8,4X21X3 GALV.	
8	VF01104944	5	NY LOCK NUT 8A3CD985	
9	VF06213700	8	CLAMP SCREW/BOLT	
10	VF16511031	8	TIGHTENING PLATE	
11	VF01112824	8	HEX. NUT	
12	VF16613374	3	PLANK/BOARD	

FeedMaster 3600T / SCRAPER FLOOR

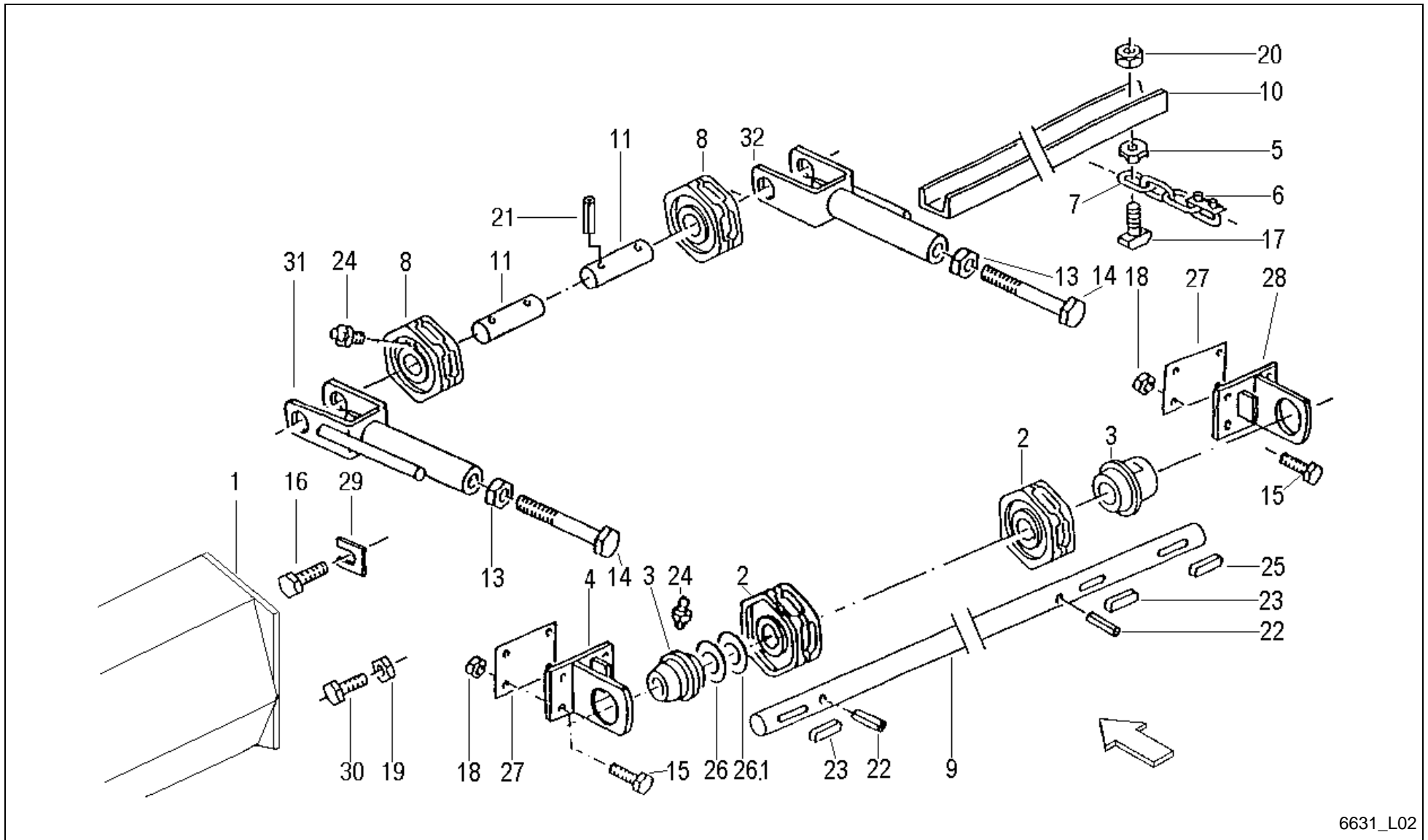

6631_L02

FeedMaster 3600T / SCRAPER FLOOR



PosNo.	Part No.	Qty.	Description	Remark
1	VF16613296	1	COVER PLATE	
2	VF06578349	2	CHAIN SPROCKET	
3	VF06577064	2	FLANGED SLEEVE	
4	VF06578750	1	SUPPORT PLATE	
5	VF06587602	40	DRIVE FLANGE	
6	VF06587598	2	CHAIN LOCK	
7	VF06578761	2	ROLLER CHAIN 10 X 31 315 CHAIN LINKS	
8	VF06578826	2	SPROCKET	
9	VF16515751	1	AXLE	
10	VF06558644	20	RAIL	
11	VF06577030	2	SHAFT	
13	VF01112916	2	HEX. NUT	
14	VF06209411	2	HEX.BOLT	
15	VF01112429	4	HEX. HEAD SCREW	
16	VF06209484	1	HEX.HEAD.SCREW	
17	VF06273686	40	HAMMER BOLT	
18	VF06209768	4	LOCK NUT	
19	VF06209769	3	LOCK NUT	
20	VF06209768	40	LOCK NUT	
21	VF01157337	4	DOWEL PIN	
22	VF01115478	2	DOWEL PIN	
23	VF01118100	2	FITTING KEY	
24	VF01120692	4	GREASE NIPPLE H1 AM 6X1 DIN 71412	
25	VF01118111	1	SUNK KEY	
26	VF06214332	4	WASHER	
26.1	VF06214333	1	WASHER	
27	VF06577968	6	SHIM	
28	VF06550287	1	SUPPORT PLATE	
29	VF06552196	6	SHIM	
30	VF01112529	3	HEX.HEAD SCREW	
31	VF16611400	1	TENSION FORK	
32	VF16611401	1	TENSION FORK	

FeedMaster 3600T / DRUM ELEVATOR GRATE 4 RAKE

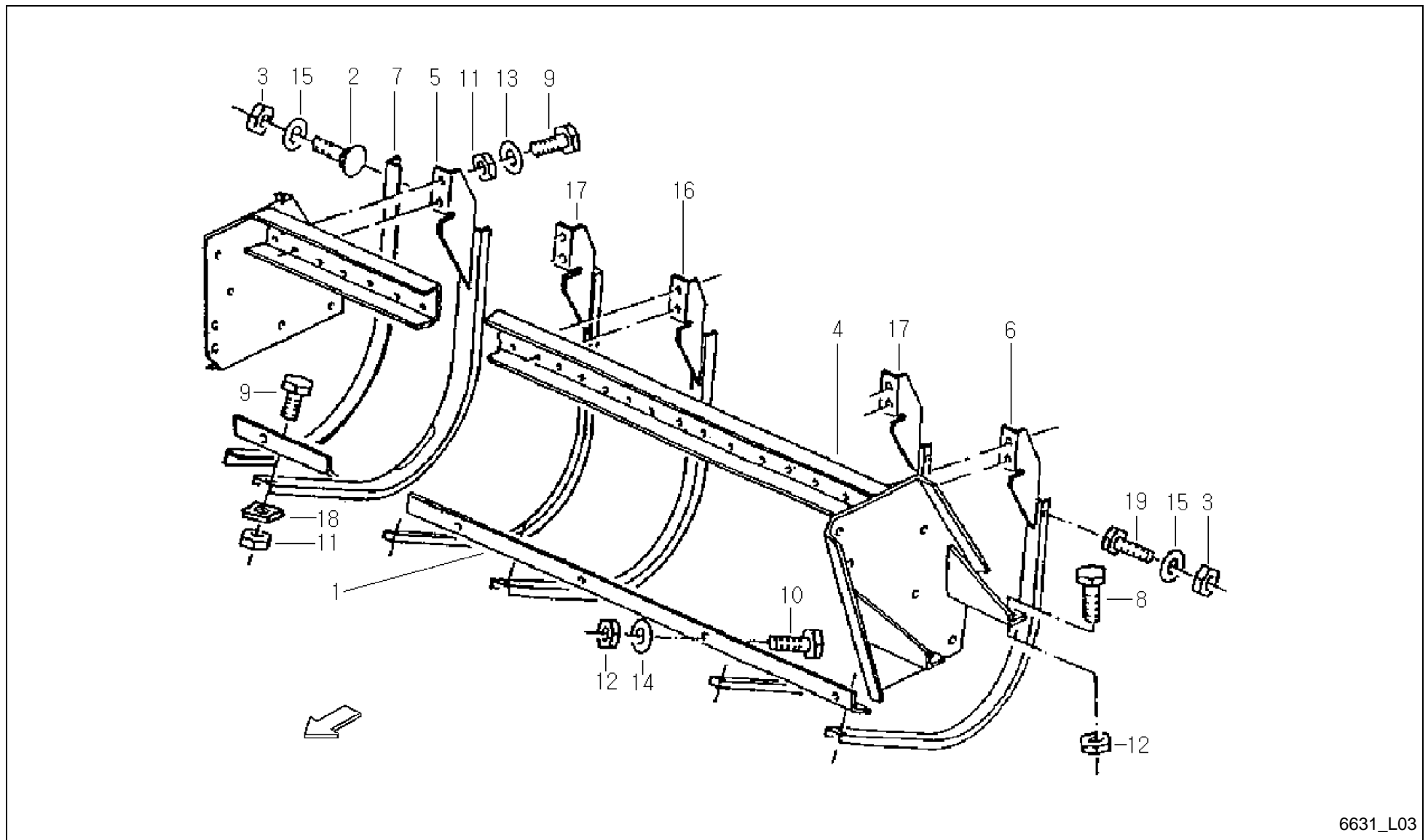

6631_L03

FeedMaster 3600T / DRUM ELEVATOR GRATE 4 RAKE



PosNo.	Part No.	Qty.	Description	Remark
1	VF16611247	1	GUIDA RAIL	
2	VF01142565	6	TRUSS-HEAD SCR. M8X20 109 GALV.	
3	VF01104944	7	NY LOCK NUT 8A3CD985	
4	VF16613354	1	SUPPORT	
5	VF16613460	1	GUIDE RAIL	
6	VF16613456	1	GUIDE RAIL	
7	VF06577579	1	ANGLE	
8	VF06209459	4	SCREW M12X35D933 8.8 A3C DIN267-27 COATE	
9	VF01112429	60	HEX. HEAD SCREW	
10	VF01112538	5	HEX.HEAD SCREW	
11	VF06209768	60	LOCK NUT	
12	VF06209769	5	LOCK NUT	
13	VF01127538	40	WASHER	
14	VF06214206	5	WASHER 13X30X4 RM=580-680 MPA A2C	
15	VF01107163	7	WASHER	
16	VF16613356	14	GUIDE RAIL	
17	VF16613458	4	BEND	
18	VF06552906	16	CLIP	
19	VF01112322	1	HEX. HEAD SCREW	

FeedMaster 3600T / DRUM ELEVATOR GRATE 6 RAKE

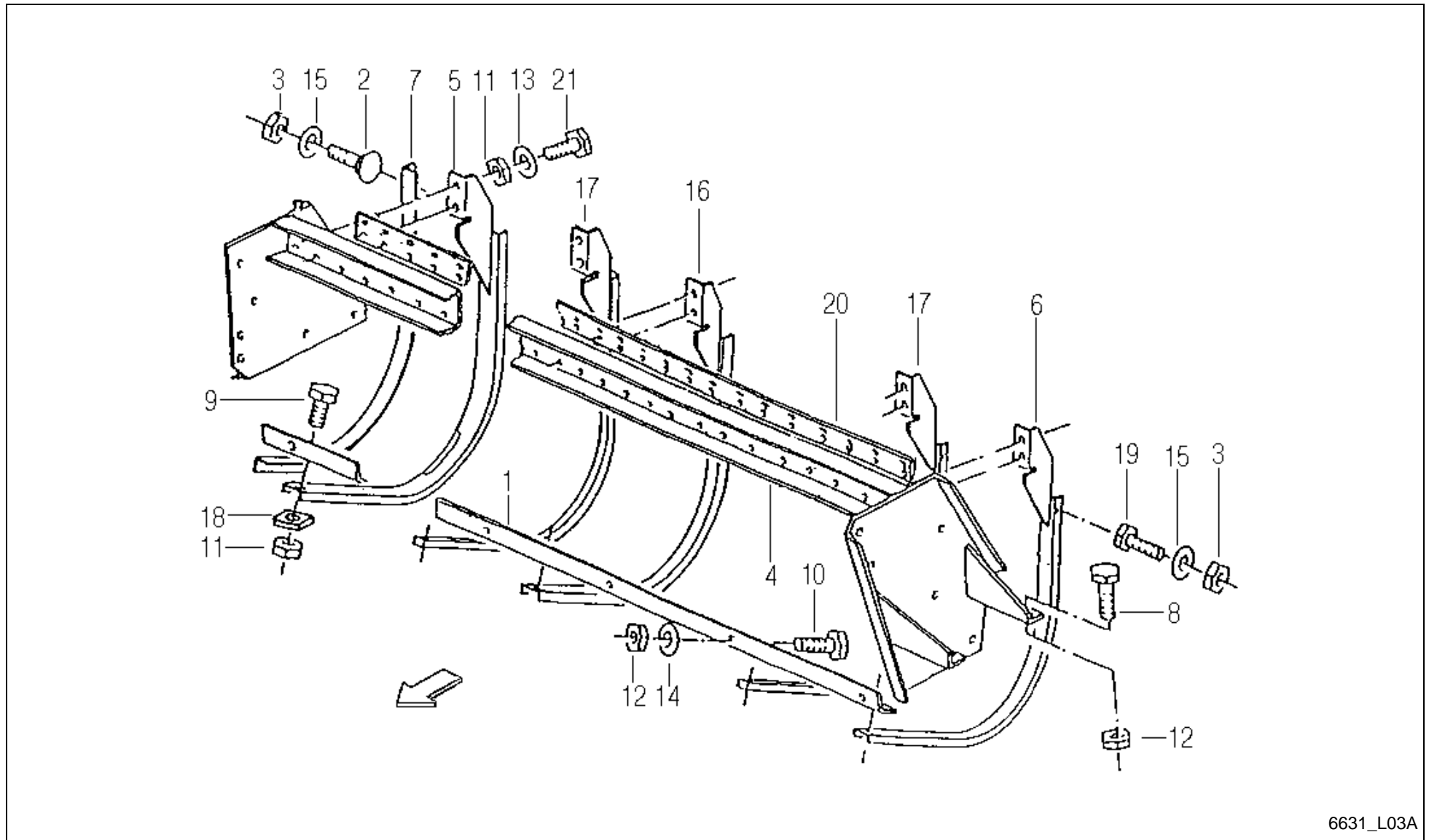

6631_L03A

FeedMaster 3600T / DRUM ELEVATOR GRATE 6 RAKE



PosNo.	Part No.	Qty.	Description	Remark
1	VF16630147	1	GUIDA RAIL	
2	VF01142565	6	TRUSS-HEAD SCR. M8X20 109 GALV.	
3	VF01104944	7	NY LOCK NUT 8A3CD985	
4	VF16613354	1	SUPPORT	
5	VF16613460	1	GUIDE RAIL	
6	VF16613456	1	GUIDE RAIL	
7	VF06577579	1	ANGLE	
8	VF06209459	4	SCREW M12X35D933 8.8 A3C DIN267-27 COATE	
9	VF01112429	20	HEX. HEAD SCREW	
10	VF01112538	5	HEX.HEAD SCREW	
11	VF06209768	60	LOCK NUT	
12	VF06209769	5	LOCK NUT	
13	VF01127538	40	WASHER	
14	VF06214206	5	WASHER 13X30X4 RM=580-680 MPA A2C	
15	VF01107163	7	WASHER	
16	VF16613356	15	GUIDE RAIL	
17	VF16613458	2	BEND	
18	VF06552906	16	CLIP	
19	VF01112322	1	HEX. HEAD SCREW	
20	VF16630148	1	PLATE	
21	VF01112447	40	HEX.HEAD SCREW	

FeedMaster 3600T / DRUM ELEVATOR GRATE 5 RAKE

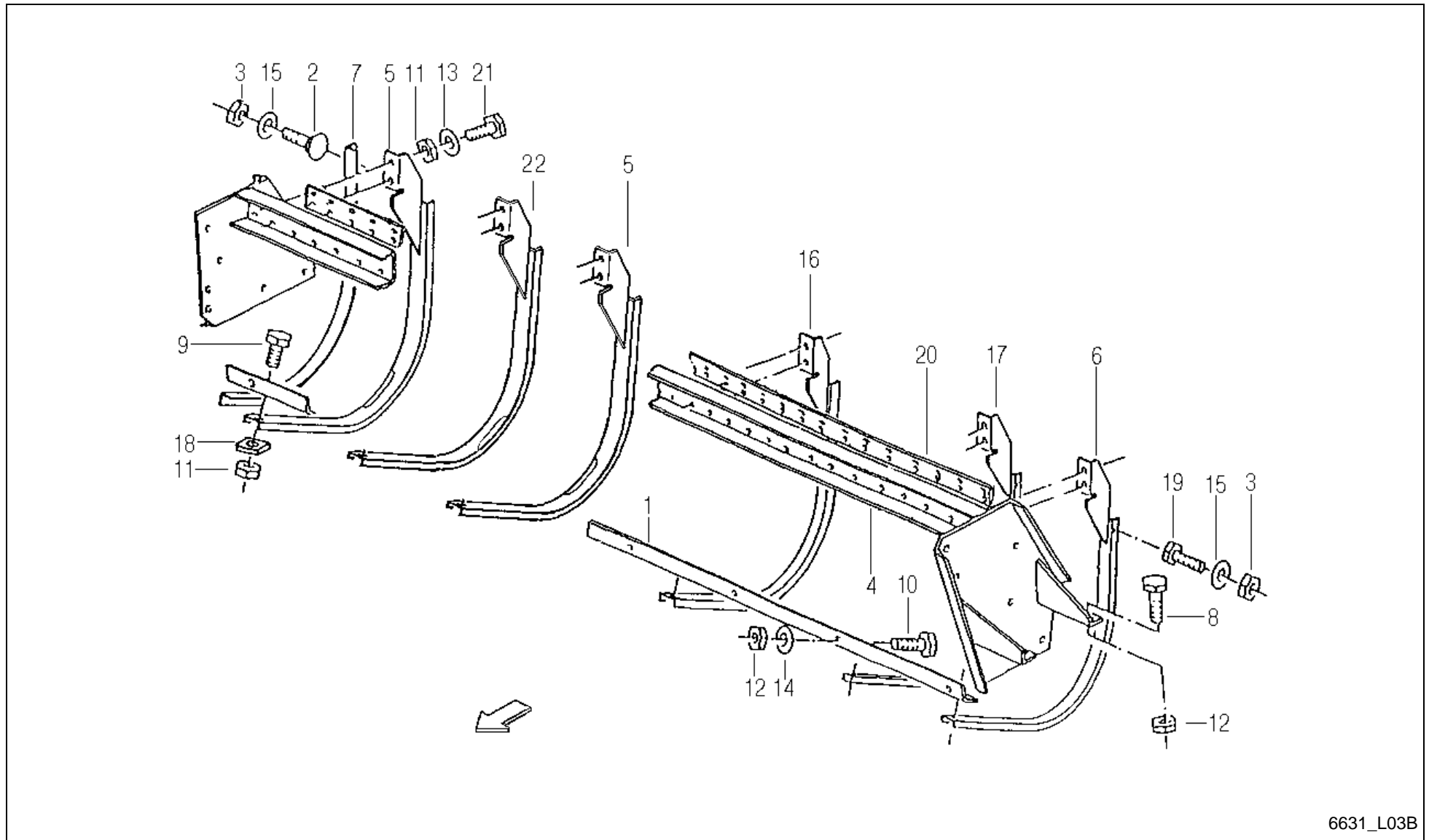

6631_L03B

FeedMaster 3600T / DRUM ELEVATOR GRATE 5 RAKE



PosNo.	Part No.	Qty.	Description	Remark
1	VF16630147	1	GUIDA RAIL	
2	VF01142565	6	TRUSS-HEAD SCR. M8X20 109 GALV.	
3	VF01104944	7	NY LOCK NUT 8A3CD985	
4	VF16613354	1	SUPPORT	
5	VF16613460	2	GUIDE RAIL	
6	VF16613456	1	GUIDE RAIL	
7	VF06577579	1	ANGLE	
8	VF06209459	4	SCREW M12X35D933 8.8 A3C DIN267-27 COATE	
9	VF01112429	20	HEX. HEAD SCREW	
10	VF01112538	5	HEX.HEAD SCREW	
11	VF06209768	60	LOCK NUT	
12	VF06209769	5	LOCK NUT	
13	VF01127538	40	WASHER	
14	VF06214206	5	WASHER 13X30X4 RM=580-680 MPA A2C	
15	VF01107163	7	WASHER	
16	VF16613356	14	GUIDE RAIL	
17	VF16613458	1	BEND	
18	VF06552906	19	CLIP	
19	VF01112322	1	HEX. HEAD SCREW	
20	VF16630148	1	PLATE	
21	VF01112447	40	HEX.HEAD SCREW	
22	VF16630964	1	GUIDE RAIL WELDED	

FeedMaster 3600T / DRUM ELEVATOR SIDE MEM. A. COV .SHEET

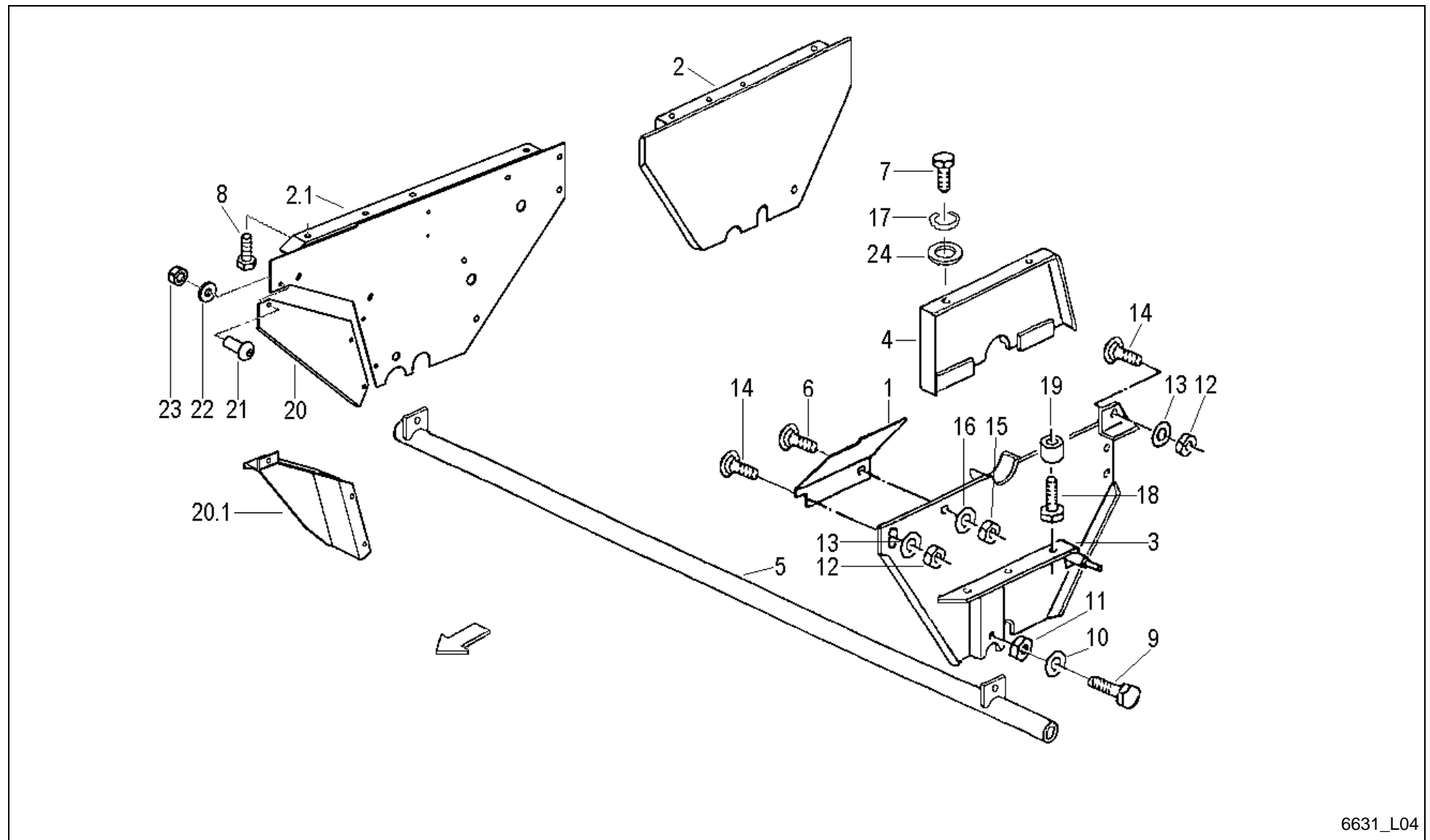

6631_L04

FeedMaster 3600T / DRUM ELEVATOR SIDE MEM. A. COV .SHEET



PosNo.	Part No.	Qty.	Description	Remark
1	VF06558937	1	SHEET	
2	VF06571198	1	SIDE MEMBER R	-A 2003, ersetzbar durch Pos.2.1+20
2.1	VF16631220	1	SIDE PANEL RIGHT WELDED	
3	VF06571196	1	SIDE MEMBER L	
4	VF06577389	1	COVERING SHEET	
5	VF06577391	1	CROSS TUBE	
6	VF01138989	1	TRUSS-HEAD SCREW	
7	VF01112407	2	HEX. HEAD SCREW	
8	VF06209459	4	SCREW M12X35D933 8.8 A3C DIN267-27 COATE	
9	VF01112709	2	HEX.BOLT	
10	VF01169697	2	RETAINING WASHER	
11	VF01112886	2	HEX. NUT	
12	VF06209768	2	LOCK NUT	
13	VF01107165	2	WASHER M10 11X20X2 A2C DIN126	
14	VF06207557	2	SAUCER HEAD SCREW	
15	VF01114357	1	LOCK NUT	
16	VF06214189	1	WASHER 6,4X18X2 A2C	
17	VF01102800	2	SPRING WASHER	
18	VF06209245	3	SCR. M12X50D931 10.9 GALV. DIN267-27	
19	VF06571325	3	SPACER RING	
20	A143047286	1	SIDE PLATE	für Pu 1.6
20.1	VF16631184	1	REFUSE PLATE	für Pu 1.8
21	VF01142565	3	TRUSS-HEAD SCR. M8X20 109 GALV.	
22	VF06214193	3	WASHER 8,4X21X3 GALV.	
23	VF01104944	3	NY LOCK NUT 8A3CD985	
24	VF06214198	2	WASHER	

FeedMaster 3600T / DRUM ELEVATOR DRUM 4- RAKE

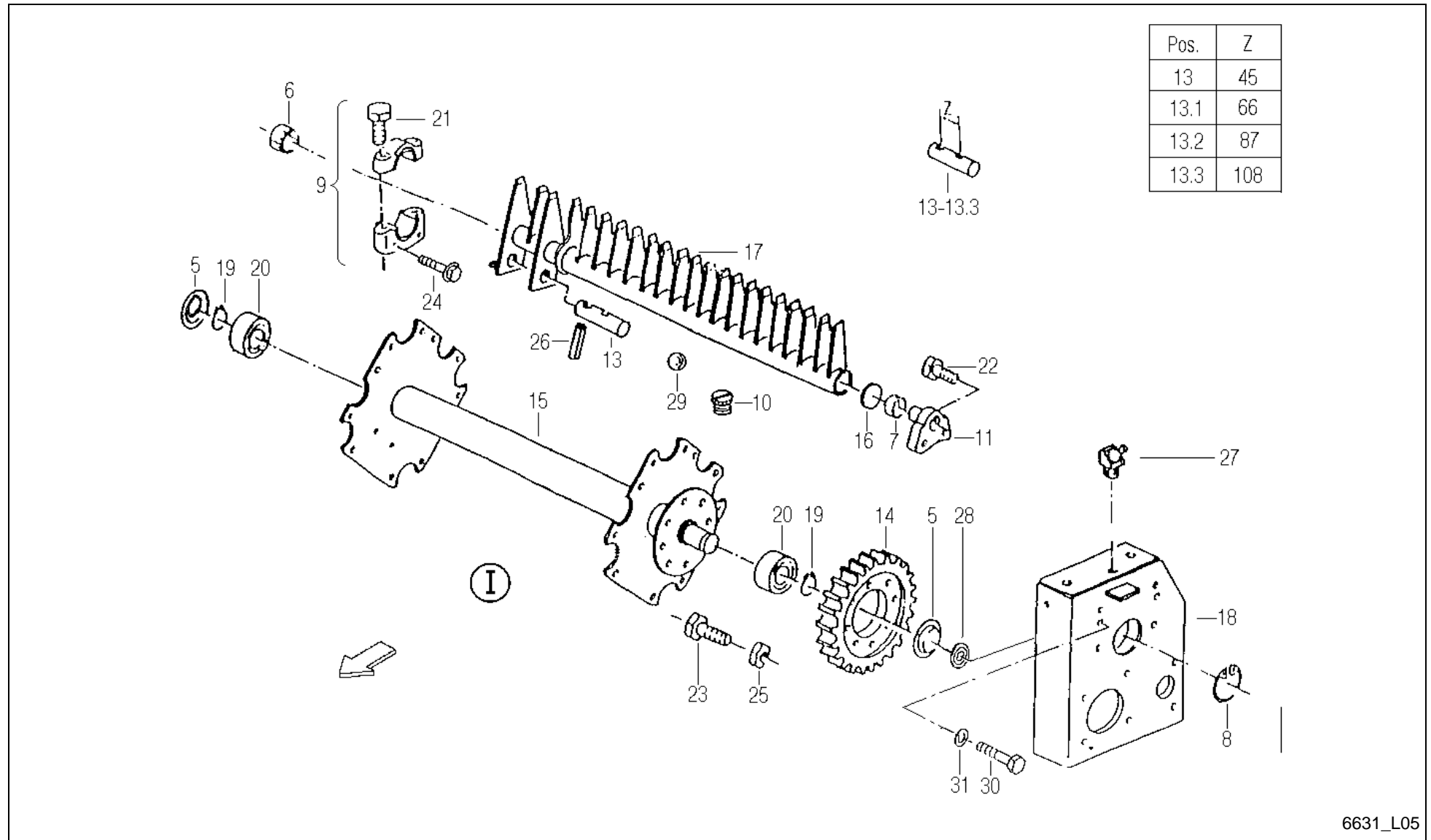

FeedMaster 3600T / DRUM ELEVATOR DRUM 4- RAKE



PosNo.	Part No.	Qty.	Description	Remark
1	A143031730	1	DRUM ELEVATOR	b L05/B+L06/B
5	VF06577317	2	CAP	
6	VF16515167	16	BEARING BRASS	
7	VF01142086	4	BUSH	
8	VF01107858	1	CIRCLIP	
9	VF16515168	4	BEARING/SUPPORT	
10	VF06216527	1	PROTECTING PLUG	
11	VF06571150	4	FLANGED PIN	
13	VF16516766	1	PIN/BOLT/STUD Z=45	
13.1	VF16516767	1	PIN/BOLT/STUD Z=66	
13.2	VF16516768	1	PIN/BOLT/STUD Z=87	
13.3	VF16516769	1	PIN/BOLT/STUD Z=108	
14	VF06577335	1	SPUR GEAR	
15	VF16516679	1	DRUM/REEL	
16	VF06578868	4	WASHER/DISC/PLATE	
17	VF16614454	4	RAKE	
18	VF16516664	1	SUPPORT PLATE	
19	VF01137321	2	RING	
20	VF01141159	2	ROLLER BEARING	
21	VF06273763	8	HEX. SCREW M12X60 I4014 8.8 A3C H2091	
22	VF06273771	8	HEX. SCREW M16X30 I4017 8.8 A3C H2091	
23	VF01112687	8	HEX. HEAD SCREW	
24	VF01142796	8	HEX.BOLT	
25	VF01127856	8	LOCK NUT	
26	VF01157381	4	DOWEL PIN	
27	VF01120696	2	GREASE NIPPLE H2 BM 6X1 DIN 71412	
28	VF16516754	1	RUBBER GROMMET	
29	VF01116946	4	BALL	
30	VF06273759	4	HEX. HEAD SCREW	
31	VF01142841	4	LOCKING WASHER	

FeedMaster 3600T / DRUM ELEVATOR DRUM 6 RAKE

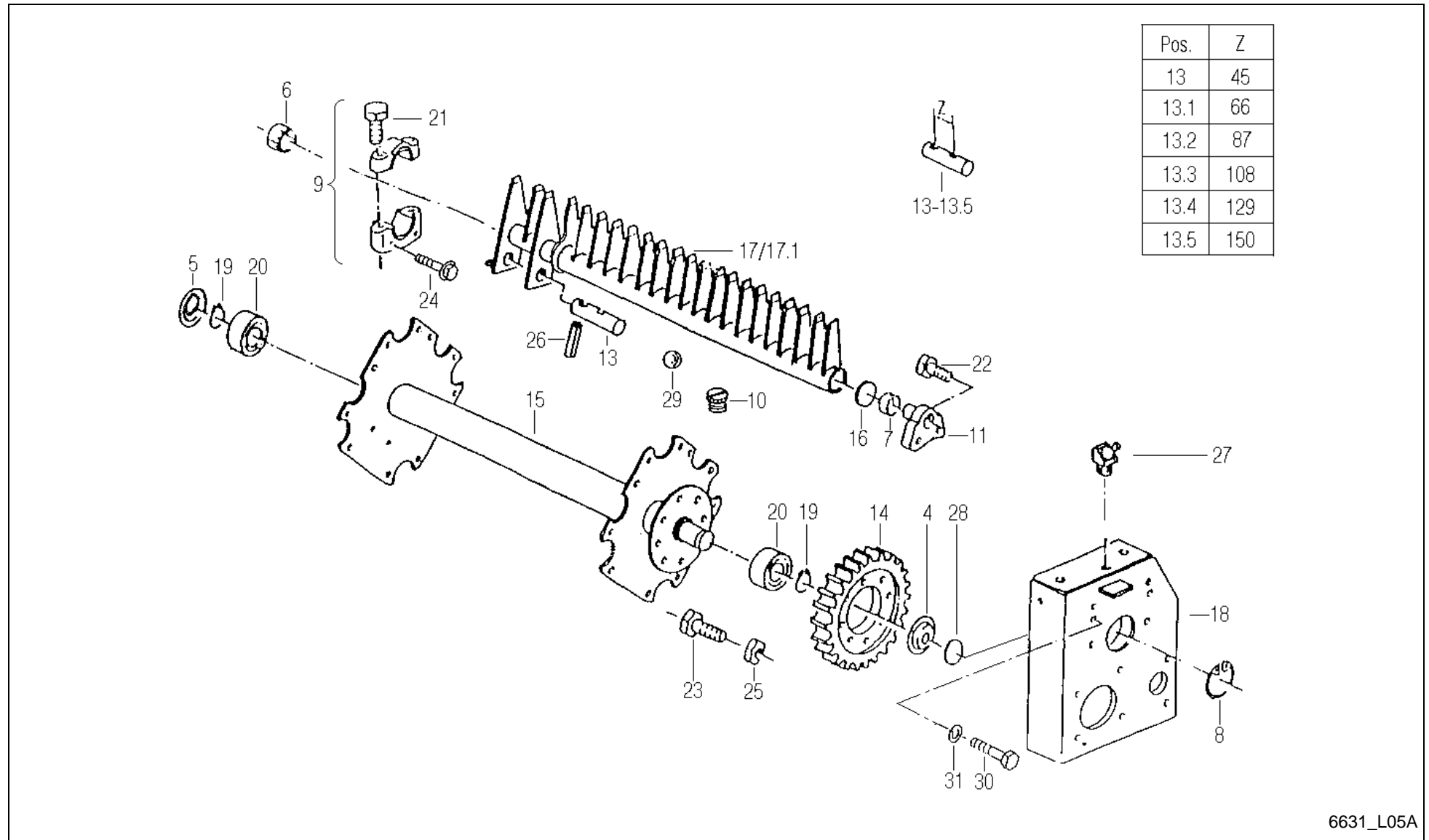

FeedMaster 3600T / DRUM ELEVATOR DRUM 6 RAKE



PosNo.	Part No.	Qty.	Description	Remark
4	VF16516663	1	COVER	
5	VF06577317	1	CAP	
6	VF16515167	24	BEARING BRASS	
7	VF01142086	6	BUSH	
8	VF01107858	1	CIRCLIP	
9	VF16515168	6	BEARING/SUPPORT	
10	VF06216527	1	PROTECTING PLUG	
11	VF06571150	6	FLANGED PIN	
13	VF16516653	1	PIN/BOLT/STUD	
13.1	VF16516654	1	STUEBERBOLZEN Z=66	
13.2	VF16516655	1	STUEBERBOLZEN Z=87	
13.3	VF16516656	1	STUEBERBOLZEN Z=108	
13.4	VF16516657	1	VALVE	
13.5	VF16516658	1	PIN/BOLT/STUD	
14	VF06577335	1	SPUR GEAR	
15	VF16513977	1	DRUM/REEL	
16	VF06578868	6	WASHER/DISC/PLATE	
17	VF16630142	3	RAKE WELDED	
17.1	VF16630143	3	RAKE WELDED	
18	VF16516664	1	SUPPORT PLATE	
19	VF01137321	2	RING	
20	VF01141159	2	ROLLER BEARING	
21	VF06273763	12	HEX. SCREW M12X60 I4014 8.8 A3C H2091	
22	VF06273771	12	HEX. SCREW M16X30 I4017 8.8 A3C H2091	
23	VF01112687	8	HEX. HEAD SCREW	
24	VF01142796	12	HEX.BOLT	
25	VF01127856	8	LOCK NUT	
26	VF01157381	6	DOWEL PIN	
27	VF01120696	2	GREASE NIPPLE H2 BM 6X1 DIN 71412	
28	VF16516754	1	RUBBER GROMMET	
29	VF01116946	6	BALL	
30	VF06273759	4	HEX. HEAD SCREW	
31	VF01142841	4	LOCKING WASHER	

FeedMaster 3600T / DRUM ELEVATOR DRUM 5 RAKE

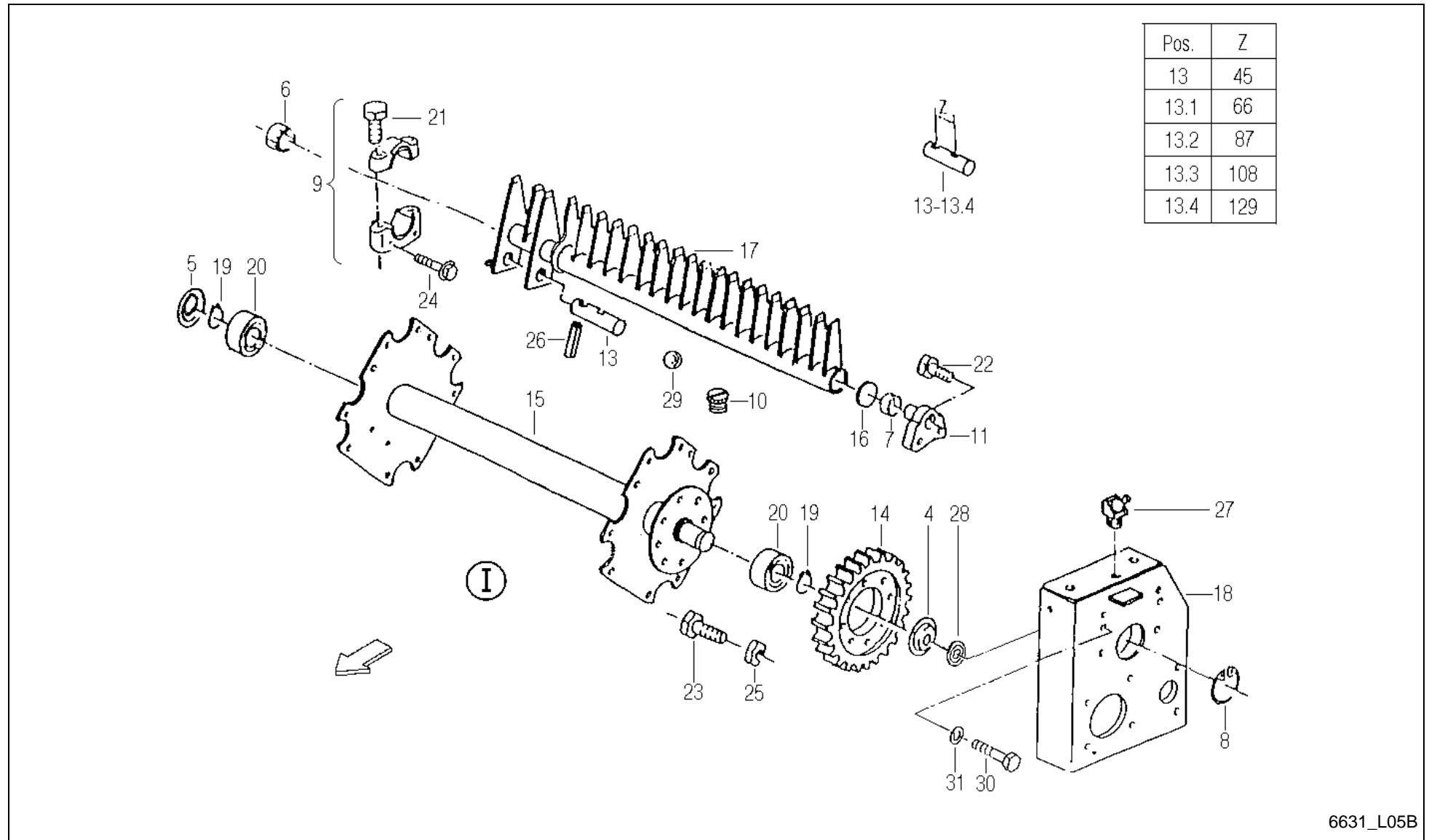

FeedMaster 3600T / DRUM ELEVATOR DRUM 5 RAKE



PosNo.	Part No.	Qty.	Description	Remark
1	A143031730	1	DRUM ELEVATOR	b L05/B+L06/B
4	VF16516663	1	COVER	
5	VF06577317	1	CAP	
6	VF16515167	20	BEARING BRASS	
7	VF01142086	5	BUSH	
8	VF01107858	1	CIRCLIP	
9	VF16515168	5	BEARING/SUPPORT	
10	VF06216527	1	PROTECTING PLUG	
11	VF06571150	5	FLANGED PIN	
13	VF16516653	1	PIN/BOLT/STUD	
13.1	VF16516654	1	STUEBERBOLZEN Z=66	
13.2	VF16516655	1	STUEBERBOLZEN Z=87	
13.3	VF16516656	1	STUEBERBOLZEN Z=108	
13.4	VF16516657	1	VALVE	
14	VF06577335	1	SPUR GEAR	
15	VF16631420	1	DRUM WELDED	
16	VF06578868	5	WASHER/DISC/PLATE	
17	VF16631920	5	RAKE WELDED	
18	VF16516664	1	SUPPORT PLATE	
19	VF01137321	2	RING	
20	VF01141159	2	ROLLER BEARING	
21	VF06273763	10	HEX. SCREW M12X60 I4014 8.8 A3C H2091	
22	VF06273771	10	HEX. SCREW M16X30 I4017 8.8 A3C H2091	
23	VF01112687	8	HEX. HEAD SCREW	
24	VF01142796	10	HEX.BOLT	
25	VF01127856	8	LOCK NUT	
26	VF01157381	5	DOWEL PIN	
27	VF01120696	2	GREASE NIPPLE H2 BM 6X1 DIN 71412	
28	VF16516754	1	RUBBER GROMMET	
29	VF01116946	5	BALL	
30	VF06273759	4	HEX. HEAD SCREW	
31	VF01142841	4	LOCKING WASHER	

FeedMaster 3600T / DRUM ELEVATOR CRANK WITH BEARING 4-RAKE

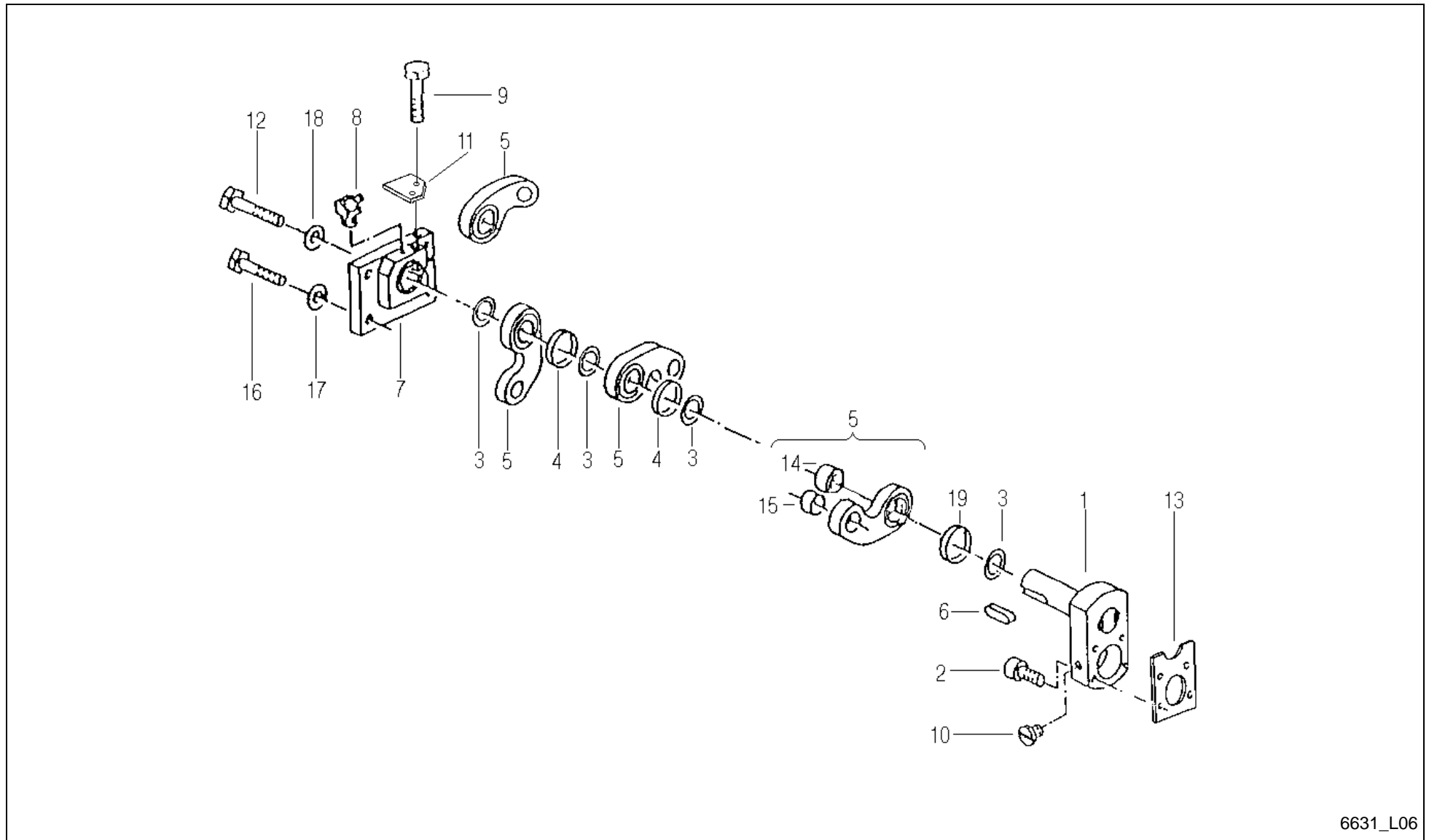

6631_L06

FeedMaster 3600T / DRUM ELEVATOR CRANK WITH BEARING 4-RAKE



PosNo.	Part No.	Qty.	Description	Remark
1	VF06577374	1	CRANK BEARING	
2	VF06273756	4	SOCKET HEAD SCREW	
3	VF06273873	7	NEEDLE BEARING	
4	VF06587559	5	SEAL RING	
5	VF16516750	4	AXLE LINK	
6	VF06277509	2	SUNK KEY	
7	VF16516772	1	FLANGE	
8	VF01120697	1	GREASE NIPPLE H2 BM 8X1 DIN 71412	
9	VF06273759	2	HEX. HEAD SCREW	
10	VF06216527	1	PROTECTING PLUG	
11	VF06577328	1	PLATE	
12	VF01139339	1	HEX.BOLT	
13	VF06553944	1	COVER	
14	VF06277518	4	BUSH 70W75X20-Y1-N2-C	
15	VF06277517	4	BEARING BUSH	
16	VF01143090	4	HEX.BOLT	
17	VF01142841	8	LOCKING WASHER	
18	A143047563	1	LOCKING WASHER	

FeedMaster 3600T / DRUM ELEVATOR CRANK WITH BEARING 6-RAKE

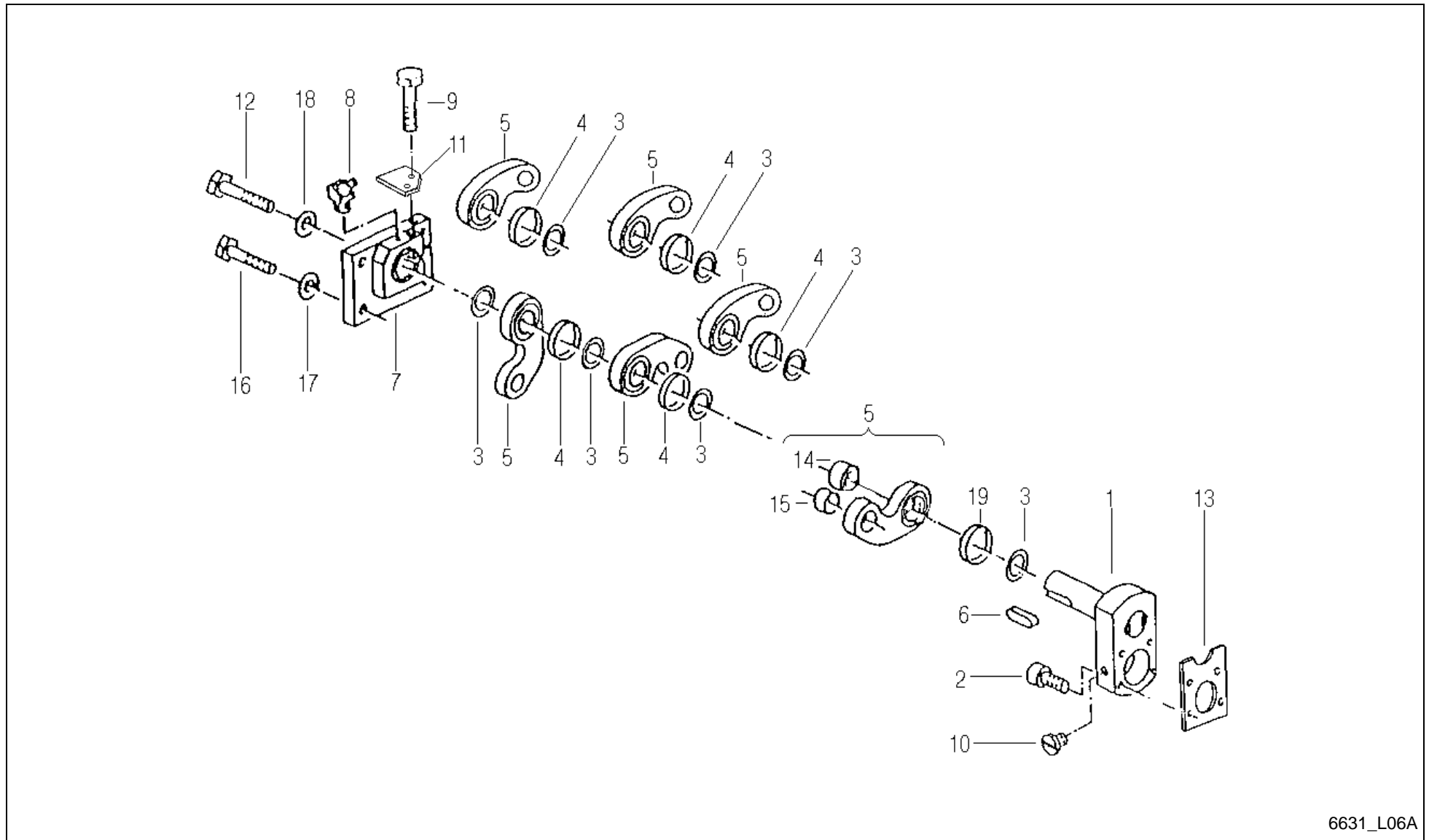

6631_L06A

FeedMaster 3600T / DRUM ELEVATOR CRANK WITH BEARING 6-RAKE



PosNo.	Part No.	Qty.	Description	Remark
1	VF16515089	1	CRANK BEARING	
2	VF06273756	4	SOCKET HEAD SCREW	
3	VF06273873	9	NEEDLE BEARING	
4	VF06587559	6	SEAL RING	
5	VF16516536	6	AXLE LINK	
6	VF06277509	2	SUNK KEY	
7	VF16516772	1	FLANGE	
8	VF01120697	1	GREASE NIPPLE H2 BM 8X1 DIN 71412	
9	VF06273759	2	HEX. HEAD SCREW	
10	VF06216527	1	PROTECTING PLUG	
12	VF16630549	1	HEXAGON HEAD SCREW M20X130 DIN931 10.9	
13	VF06553944	1	COVER	
14	VF16630146	6	BUSH	
15	VF06277517	6	BEARING BUSH	
16	VF16630548	4	HEXAGON HEAD SCREW M16X130 D931 10.9	
17	VF01142841	6	LOCKING WASHER	
18	A143047563	11	LOCKING WASHER	
19	VF16630145	1	SEAL RING	

FeedMaster 3600T / DRUM ELEVATOR CRANK WITH BEARING 5-RAKE

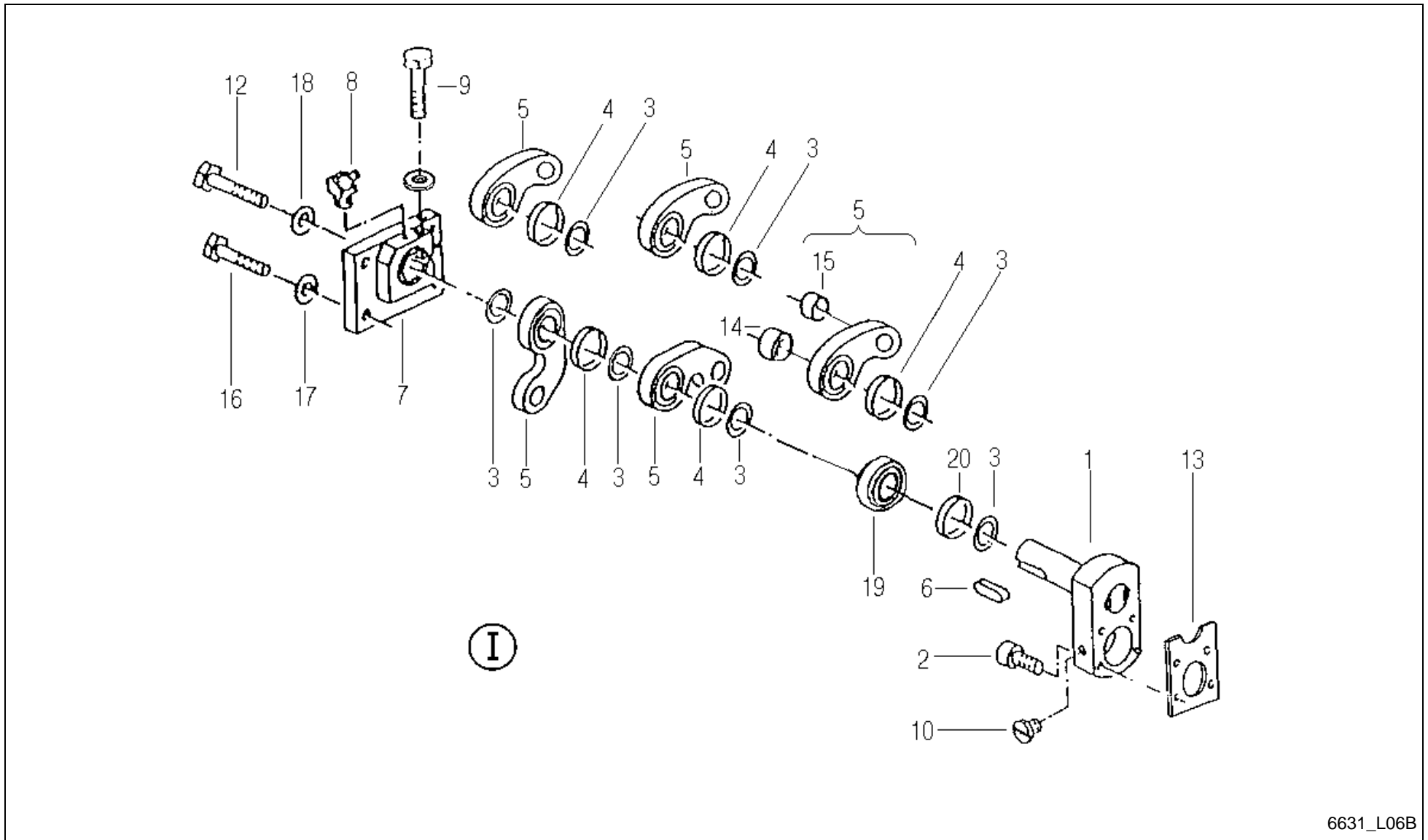

6631_L06B

FeedMaster 3600T / DRUM ELEVATOR CRANK WITH BEARING 5-RAKE



PosNo.	Part No.	Qty.	Description	Remark
1	A143031730	1	DRUM ELEVATOR	b L05/B+L06/B
1	VF16515089	1	CRANK BEARING	
2	VF06273756	4	SOCKET HEAD SCREW	
3	VF06273873	8	NEEDLE BEARING	
4	VF06587559	6	SEAL RING	
5	VF16631919	5	GUIDE	
6	VF06277509	2	SUNK KEY	
7	VF16516772	1	FLANGE	
8	VF01120697	1	GREASE NIPPLE H2 BM 8X1 DIN 71412	
9	VF06273759	2	HEX. HEAD SCREW	
10	VF06216527	1	PROTECTING PLUG	
12	VF01139339	1	HEX.BOLT	
13	VF06553944	1	COVER	
14	VF06277518	5	BUSH 70W75X20-Y1-N2-C	
15	VF06277517	5	BEARING BUSH	
16	VF01143090	4	HEX.BOLT	
17	VF01142841	4	LOCKING WASHER	
18	A143047563	1	LOCKING WASHER	
19	VF16631687	1	FEEDER COMB RING COMPLETE -	
20	VF16630145	1	SEAL RING	

FeedMaster 3600T / DRUM ELEVATOR PINION SHAFT

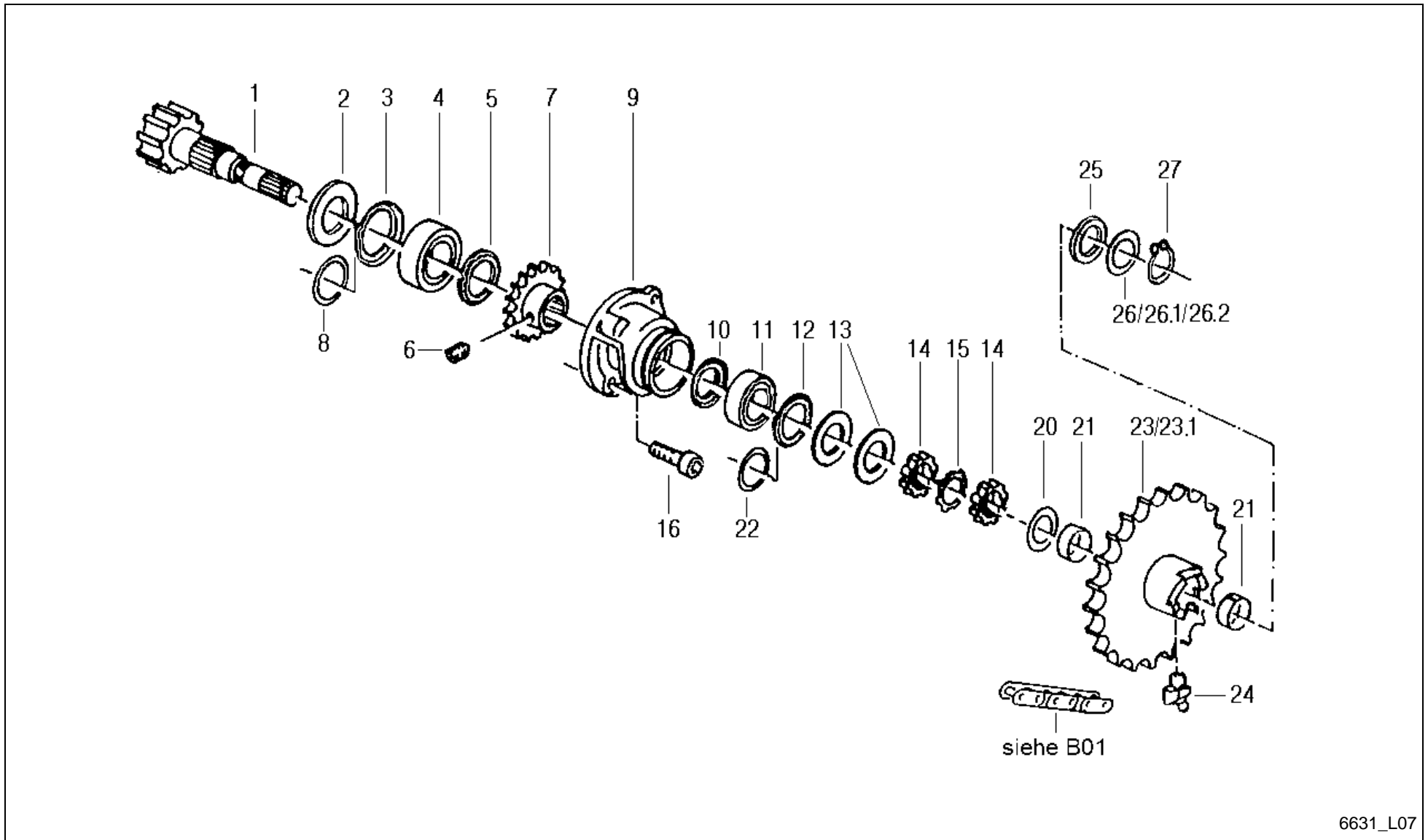

6631_L07

FeedMaster 3600T / DRUM ELEVATOR PINION SHAFT



PosNo.	Part No.	Qty.	Description	Remark
1	VF06571032	1	PINION SHAFT	
2	VF06571205	1	SEALING WASHER	
3	VF06214950	1	NILOS RING	
4	VF01109962	1	TAPER R. BEARING	
5	VF06273872	1	NILOS RING	
6	VF06208934	1	FITTING DIN 914 M 10X16 10.9=32 HRC	
7	VF06570914	1	CHAIN SPROCKET 3/4" - Z=19	
8	VF01137990	1	SPACER 60X75X1,0 D988	
9	VF06577305	1	BEARING HOUSING	
10	VF06273871	1	NILOS RING	
11	VF01109960	1	TAPER R. BEARING	
12	VF06214948	1	NILOS RING	
13	VF06570007	2	SEALING WASHER	
14	VF01120613	2	GROOVED NUT	
15	VF01120671	1	LOCKING PLATE	
16	VF01175657	4	SCR.M16X40D912 8.8 GALV.DIN267-27MKL	
20	VF06215016	1	THRUST WASHER AS 4565 45X65X1	
21	VF01139735	2	BUSH	
22	VF06214504	1	SPACER 50X62X1 D988	
23	VF06579358	1	HUB	+A 2006
23.1	VF16630151	1	HUB	-A 2005 für 6R, +A 2006 mit Pos. 23
24	VF01120700	1	GREASE FITT. 90DEGR. H3 CM 8X1 DIN 71412	
25	VF06571033	1	RING	
26	VF06214500	1	WASHER 45X55X1,0 DIN 988	
26.1	VF06214499	1	SPACER 45X55X0,5 D988	
26.2	VF01137130	1	SHIM 45X55X3 DIN988-2	
27	VF01124663	1	CIRCLIP	

FeedMaster 3600T / DRUM ELEVATOR RELEASE LEVER

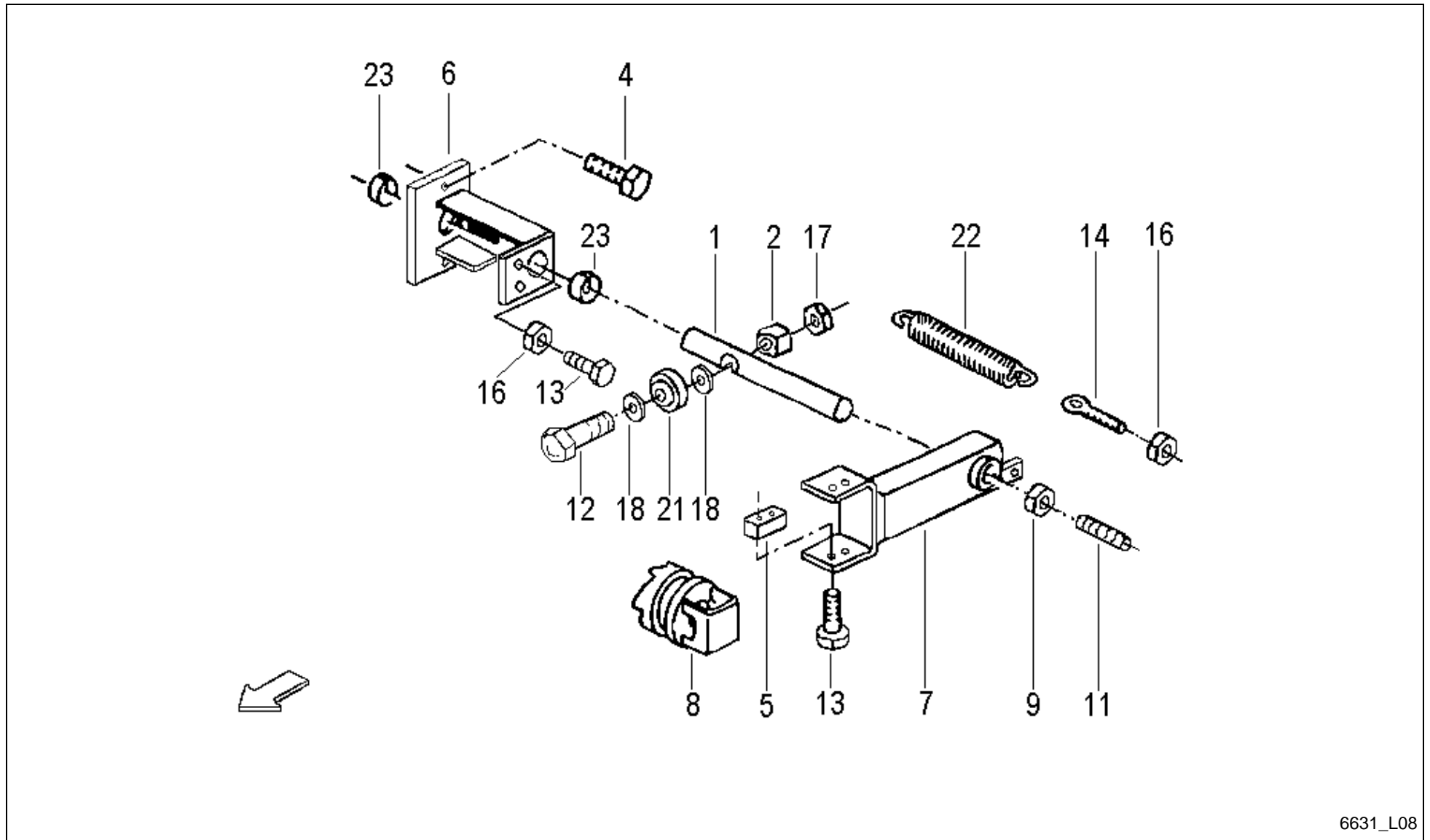

6631_L08

FeedMaster 3600T / DRUM ELEVATOR RELEASE LEVER



PosNo.	Part No.	Qty.	Description	Remark
1	VF06577348	1	PIN	
2	VF06577349	1	GUIDE PIECE	
4	VF06277504	2	HEX. HEAD SCREW	
5	VF06587560	1	SLIDE PIECE	
6	VF16630385	1	SUPPORT WITH BUSH	
7	VF06577385	1	DISCONN.FORK	
8	VF06556728	1	SLIDE CLATCH	
9	VF01137252	1	HEXNUT	
11	VF06208962	1	THREADED PIN	
12	KG00358261	1	HEX. BOLT M12X90 8.8	
13	VF01112333	6	HEX. HEAD SCREW	
14	VF01138951	1	EYE BOLT LBM 8X 50 DIN 444 - 4.6	
16	VF01112824	4	HEX. NUT	
17	VF06209769	1	LOCK NUT	
18	VF06214207	3	WASHER	
21	VF06215029	1	ROLLER LR 201 KRRU AH 01 12X35X15	
22	VF06215561	1	TENSION SPRING	
23	VF06277514	2	BUSH	

FeedMaster 3600T / PROT.HOOD

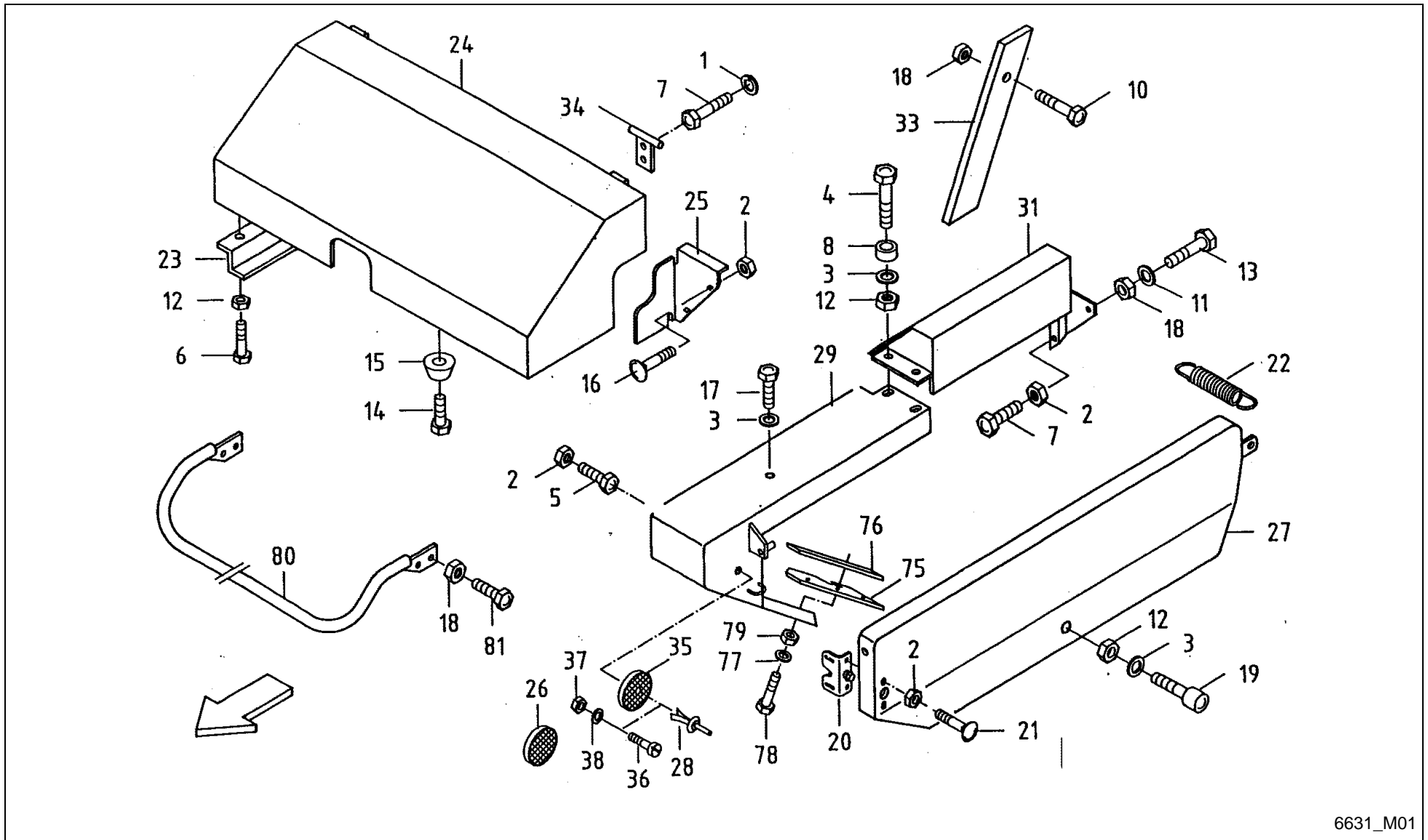

6631_M01

FeedMaster 3600T / PROT.HOOD



PosNo.	Part No.	Qty.	Description	Remark
1	VF01102799	4	SPRING WASHER	
2	VF01104944	10	NY LOCK NUT 8A3CD985	
3	VF06214189	7	WASHER 6,4X18X2 A2C	
4	VF01111079	2	HEX.BOLT	
5	VF01111153	1	HEX. HEAD SCREW	
5	VF01112322	1	HEX. HEAD SCREW	
6	VF01112240	3	HEX. HEAD SCREW	
7	VF01112307	6	HEX. HEAD SCREW	
8	VF16518913	2	PIPE/TUBE	
10	VF01112429	1	HEX. HEAD SCREW	
11	VF01107165	2	WASHER M10 11X20X2 A2C DIN126	
12	VF01114357	6	LOCK NUT	
13	VF01112407	1	HEX. HEAD SCREW	
14	VF01126049	2	SCREW	
15	VF01141112	2	RUBBER PAD	
16	VF01141006	2	TRUSS-HEAD SCR. M8X16 109 GALV.	
17	VF01103316	1	HEX. HEAD SCREW	
18	VF06209768	6	LOCK NUT	
19	VF01142826	1	RUBBER PAD	
20	VF16611457	1	LOCK	
21	VF01142565	2	TRUSS-HEAD SCR. M8X20 109 GALV.	
22	VF16613359	1	TENSION SPRING	
23	VF06556821	1	CROSS BAR	
24	VF06556826.80	1	GUARD - GREEN	
25	VF06579350	1	COVER PLATE	
26	VF06214037	2	REFLEX, CIRCULAR YELLOW, ADHESIVE D60	
27	A143031880	1	PROTECTION COVER	
28	VF06214992	2	RIVET	
29	VF16611458	1	JACKET PLATE	
31	A143031980	1	COVERING SHEET	
33	VF06577514	1	SUPPORT	
34	VF06577521	2	HINGE	
35	VF06214036	2	REAR REFLECT.YELLOW	
36	VF01105593	4	CHEESE-HEAD SCREW	
37	VF06209765	2	LOCK NUT M5 8 GALV. DIN985	
38	VF06214189	2	WASHER 6,4X18X2 A2C	
75	VF16611397	1	RUBBER STRIP	
76	VF16611398	1	STRIP	
77	VF01107095	3	WASHER 6,4DIN125 GALV.	
78	VF01112264	3	HEX. HEAD SCREW	

FeedMaster 3600T / PROT.HOOD

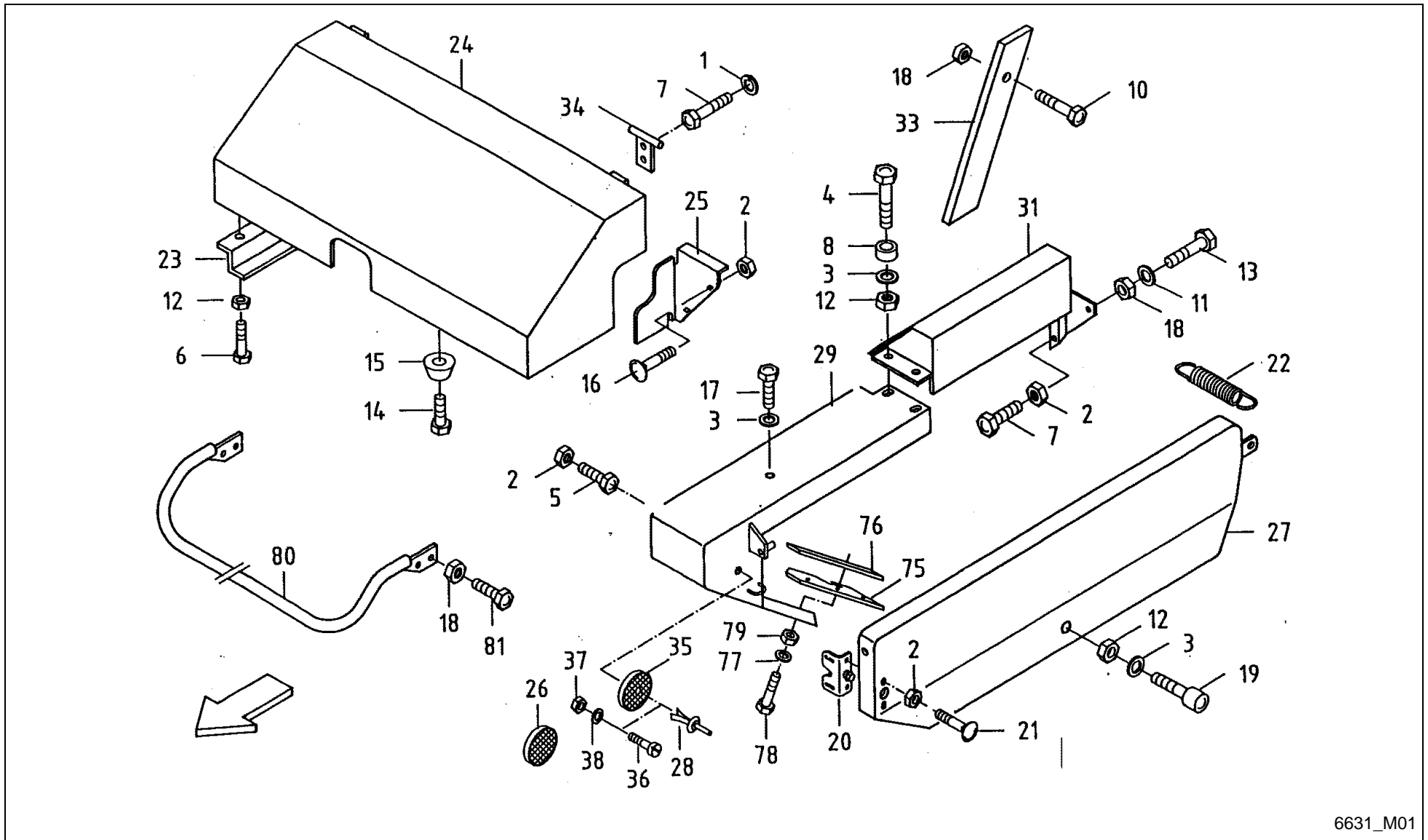

6631_M01

FeedMaster 3600T / PROT.HOOD



PosNo.	Part No.	Qty.	Description	Remark
79	VF01114357	3	LOCK NUT	
80	VF16611431	1	PROTECTIVE YOKE	-540
80	VF16630126	1	PROTECTIVE YOKE	+541
81	VF01112439	4	HEX. HEAD SCREW	

FeedMaster 3600T / MUDGUARD SMALL TANDEM AXLE

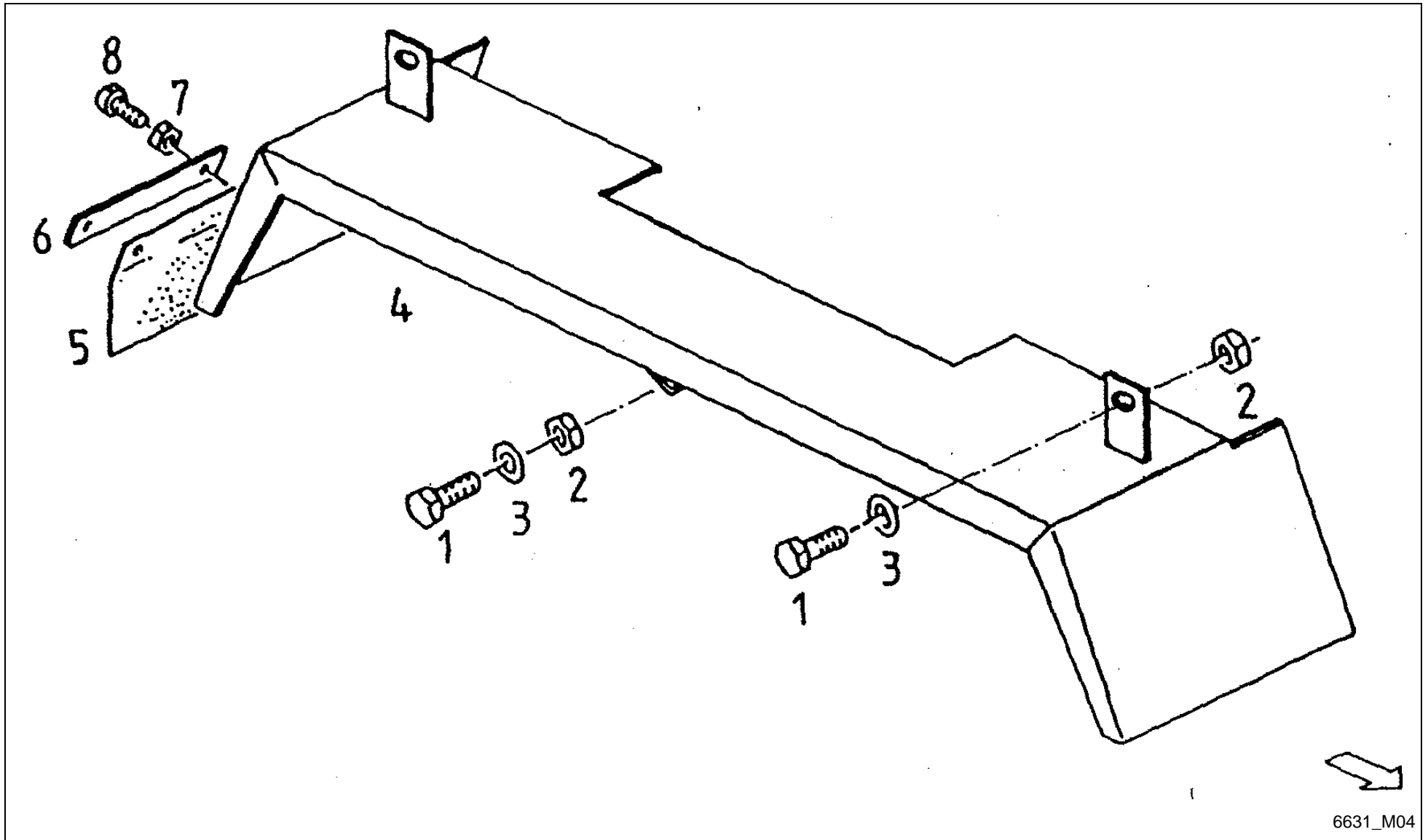

6631_M04

FeedMaster 3600T / MUDGUARD SMALL TANDEM AXLE



PosNo.	Part No.	Qty.	Description	Remark
1	VF01112439	8	HEX. HEAD SCREW	
2	VF06209768	8	LOCK NUT	
3	VF06214197	8	WASHER 10,5X30X3 GALV.	
4	VF16610586	2	MUDGUARD	
5	VF06577918	2	SUPPOR	
6	VF06577919	2	STRIP	
7	VF01114357	8	LOCK NUT	
8	VF01133784	8	CHEESE HEAD SCREW	

FeedMaster 3600T / MUDGUARD BROAD TANDEM AXLE

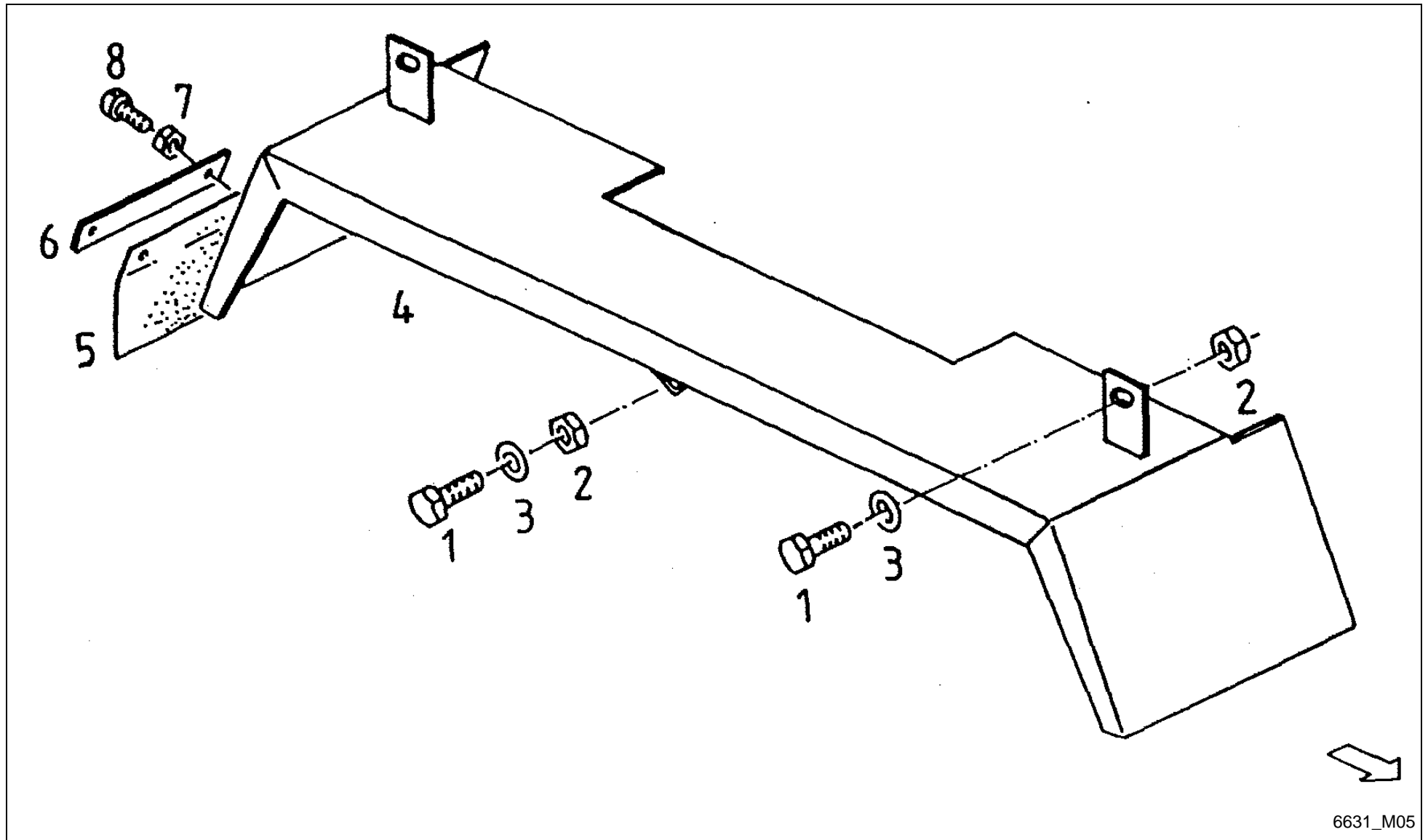

6631_M05

FeedMaster 3600T / MUDGUARD BROAD TANDEM AXLE



PosNo.	Part No.	Qty.	Description	Remark
1	VF01112439	8	HEX. HEAD SCREW	
2	VF06209768	8	LOCK NUT	
3	VF06214197	8	WASHER 10,5X30X3 GALV.	
4	VF16517079	2	MUDGUARD	
5	VF16516652	2	SUPPOR	
6	VF16516651	2	STRIP	
7	VF01114357	8	LOCK NUT	
8	VF01133784	8	CHEESE HEAD SCREW	

FeedMaster 3600T / CUTTING DEVICE

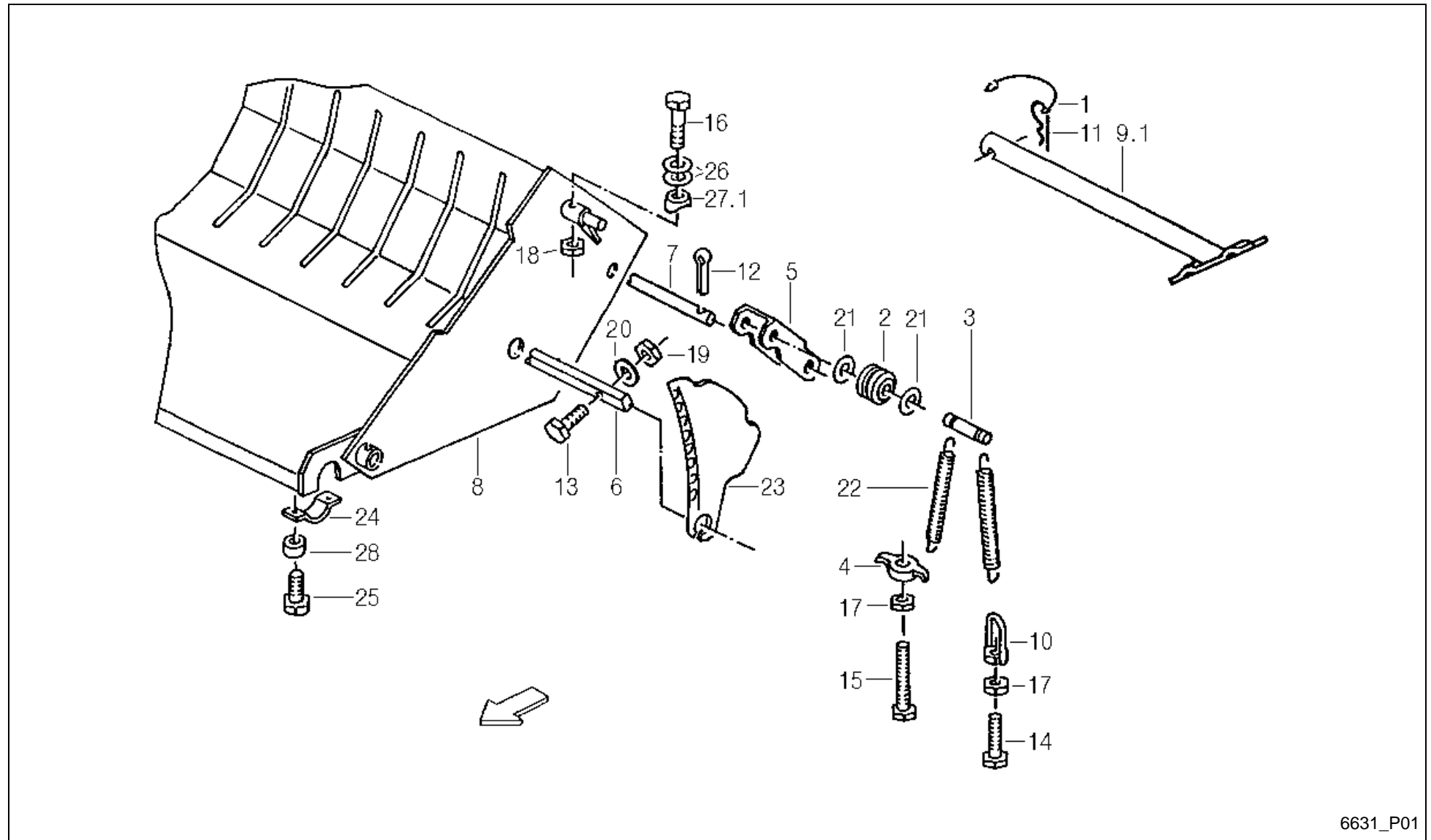

6631_P01

FeedMaster 3600T / CUTTING DEVICE



PosNo.	Part No.	Qty.	Description	Remark
1	VF06564448	1	CORD L= 240 COLOUR BLACK	
2	VF06577109	17	ROLLER	
3	VF06577110	17	PIN	
4	VF06577111	16	TIGHTENING PLATE	
5	VF06577442	17	YOKE	
6	VF16511336	1	AXLE	
7	VF06577583	1	AXLE	
8	VF06571172	1	CUTTING DEVICE	
9.1	VF16631279	1	RELEASE LEVER	+A 2005
10	VF06577496	2	NUT	
11	VF06264206	1	SPRING	
12	VF01106451	18	SPLIT PIN	
13	VF01112439	16	HEX. HEAD SCREW	
14	VF01112451	2	HEX. HEAD SCREW	
15	VF01112476	16	HEX. HEAD SCREW	
16	VF01111522	2	HEX. BOLT	
17	VF01102659	18	HEX. NUT	
18	VF06209769	2	LOCK NUT	
19	VF06209768	16	LOCK NUT	
20	VF01127538	16	WASHER	
21	VF06214206	34	WASHER 13X30X4 RM=580-680 MPA A2C	
22	VF06215561	34	TENSION SPRING	
23	VF06278720	17	KNIFE	
24	VF06578892	2	YOKE/RETAINER	
25	VF01177466	4	SCR.M10X30D933 8.8 GALV.DIN267-27MKL	
26	VF06214207	10	WASHER	
27.1	VF16606401	2	SHIM	
28	VF06562016	4	WASHER	

FeedMaster 3600T / DOUBLE-CHOPM EQUIPERN.

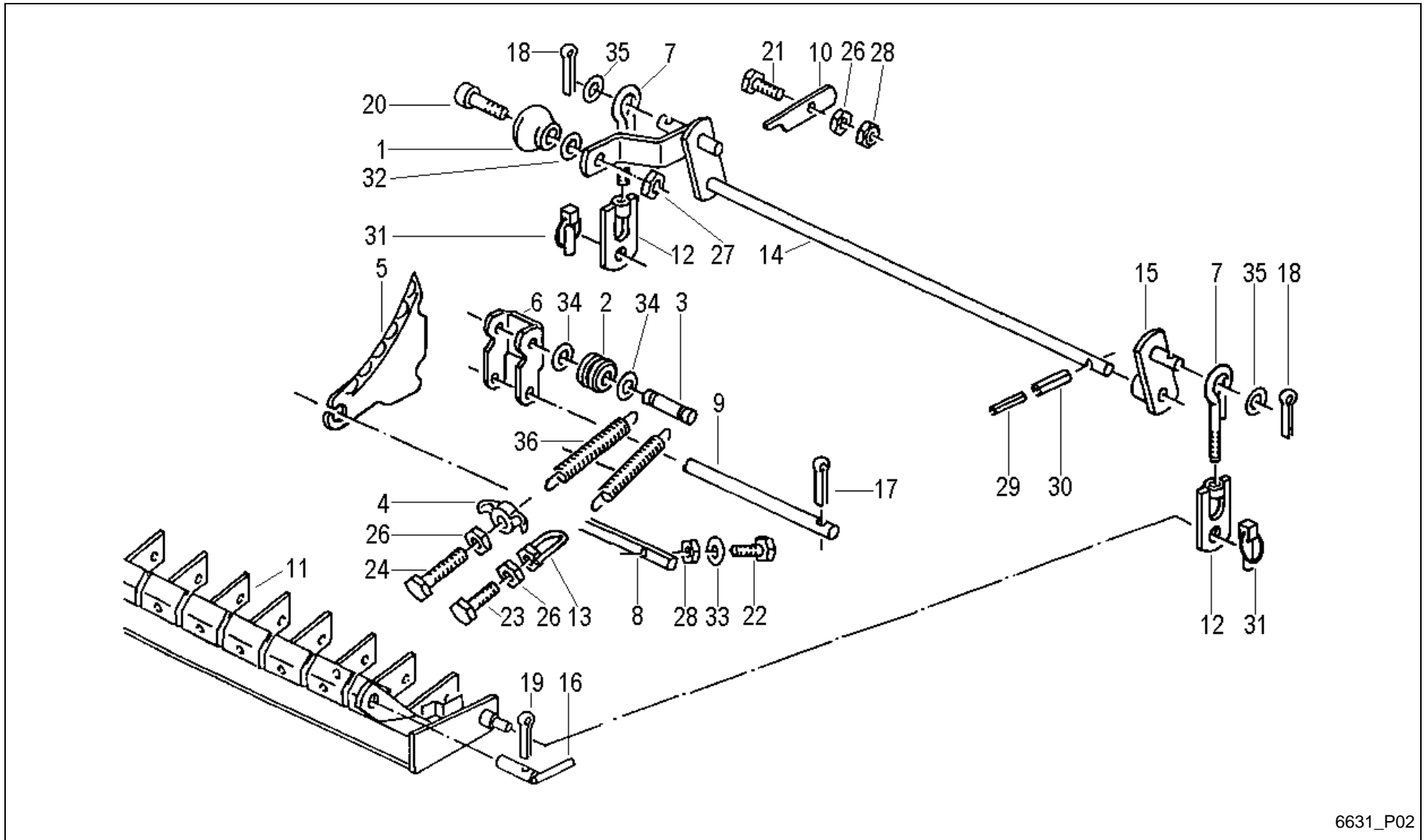

6631_P02

FeedMaster 3600T / DOUBLE-CHOPM EQUIPERN.



PosNo.	Part No.	Qty.	Description	Remark
1	VF06243750	1	BALL	
2	VF06577109	16	ROLLER	
3	VF06577110	16	PIN	
4	VF06577111	16	TIGHTENING PLATE	
5	VF06278720	16	KNIFE	
6	VF06577442	16	YOKE	
7	VF06577483	2	EYEBOLT	
8	VF16511337	1	KNIFE AXLE	
9	VF06577586	1	AXLE	
10	VF06577489	1	FLAT CATCH	
11	VF06571186	1	SUPPORT	
12	VF06577494	2	TRACTION EYE	
13	VF06577496	2	NUT	
14	VF06570195	1	TORSION ROD	
15	VF06570185	1	LEVER	
16	VF06577498	2	FIXING PIN	
17	VF01106451	16	SPLIT PIN	
18	VF01122072	2	SPLIT PIN	
19	VF01143009	2	SPLIT PIN	
20	VF01101405	1	SCREW	
21	VF01112429	1	HEX. HEAD SCREW	
22	VF01112439	15	HEX. HEAD SCREW	
23	VF01112451	2	HEX. HEAD SCREW	
24	VF01112476	16	HEX. HEAD SCREW	
26	VF01102659	18	HEX. NUT	
27	VF01104944	1	NY LOCK NUT 8A3CD985	
28	VF06209768	16	LOCK NUT	
29	VF01157344	1	DOWEL PIN	
30	VF01138412	1	DOWEL PIN	
31	VF01126332	2	DOWEL PIN	
32	VF01138374	1	WASHER	
33	VF01107165	15	WASHER M10 11X20X2 A2C DIN126	
34	VF06214206	32	WASHER 13X30X4 RM=580-680 MPA A2C	
35	VF06214226	2	WASHER	
36	VF06215561	32	TENSION SPRING	

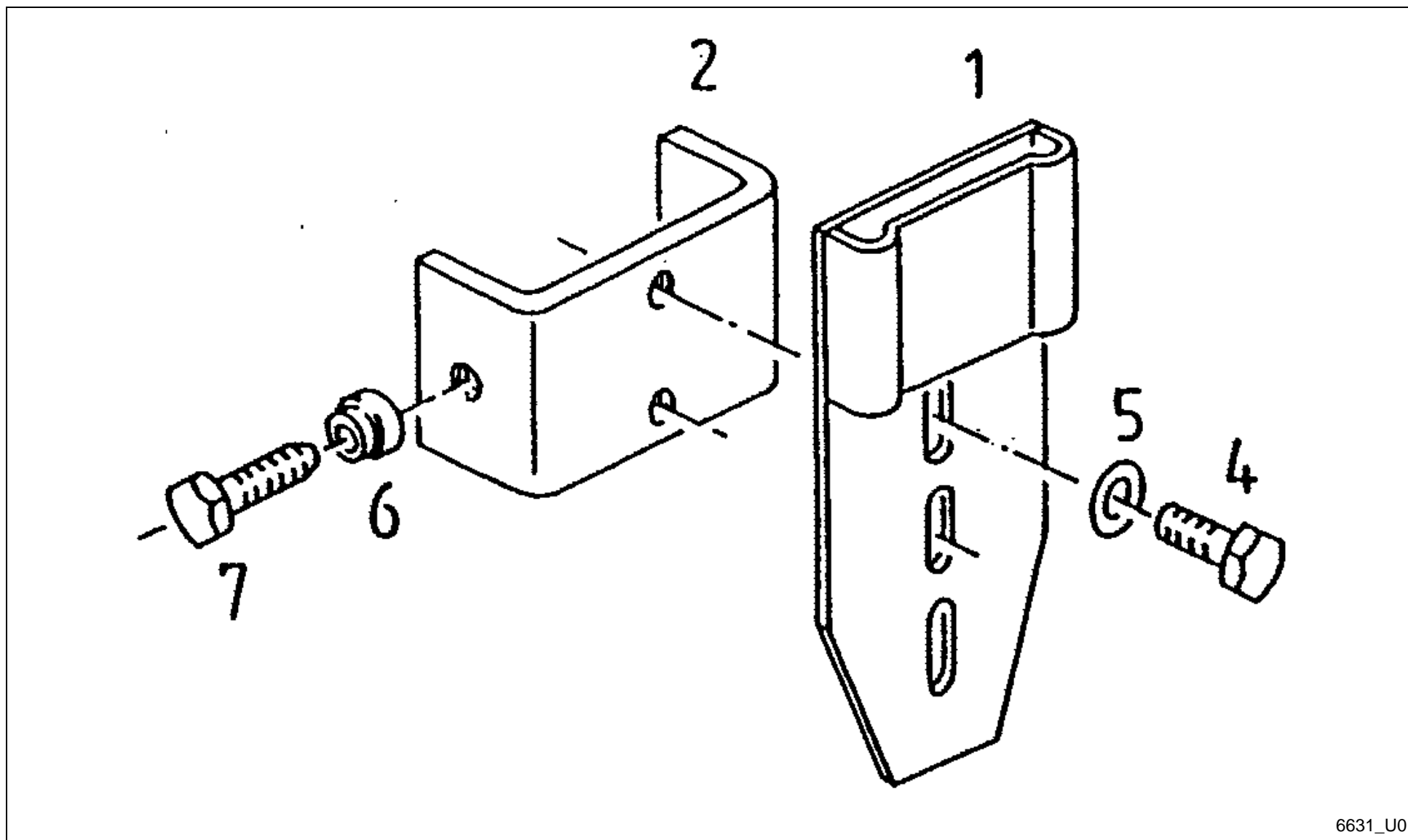

6631_U01

FeedMaster 3600T / INSTRUMENT BOARD FOR TÉLÉ COMMAND.



PosNo.	Part No.	Qty.	Description	Remark
1	VF06570724	1	SUPPORT	
2	VF06570740	1	YOKE	
4	VF01126186	2	HEX. HEAD SCREW	
5	VF01127538	2	WASHER	
6	VF01139650	1	THRUST PIECE	X 2
7	VF01142049	1	PRESSURE SCREW	X 2

FeedMaster 3600T / WARNING DECAL EU

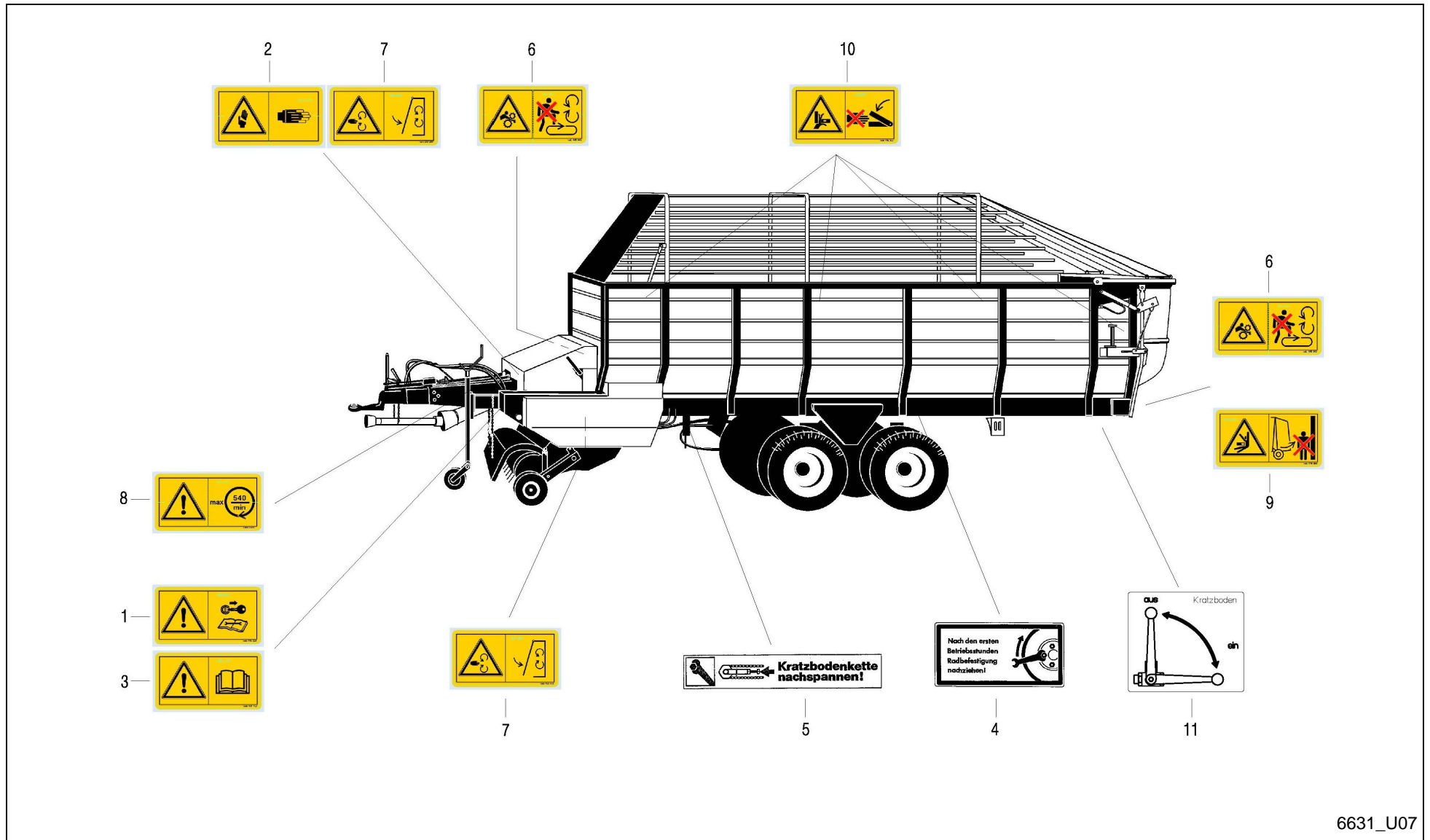

6631_U07

FeedMaster 3600T / WARNING DECAL EU



PosNo.	Part No.	Qty.	Description	Remark
1	VF16601350	1	WARNING DECAL SWITCH OF THE ENGINE	
2	VF16613392	1	WARNING PLATE	
3	VF16613391	1	WARNING DECAL READ OPENING MANUAL	
4	VF06216097	1	MARKING PLATE	
5	A143019674	1	STICKER CHAIN TIGHTEN	
6	VF16613390	2	WARNING PLATE	
7	VF16613728	3	WARNSCHILD	
8	VF16601375	1	WARNING DECAL MAX. 540 RPM	
9	VF16613719	8	WARNING DECAL RISK OF CRUSHING	
10	VF16613389	1	AUFKLEBER WARNSCHILD .	
11	A143019774	1	STICKER HANDLING SCRAPER FLOOR	

FeedMaster 3600T / DECALS

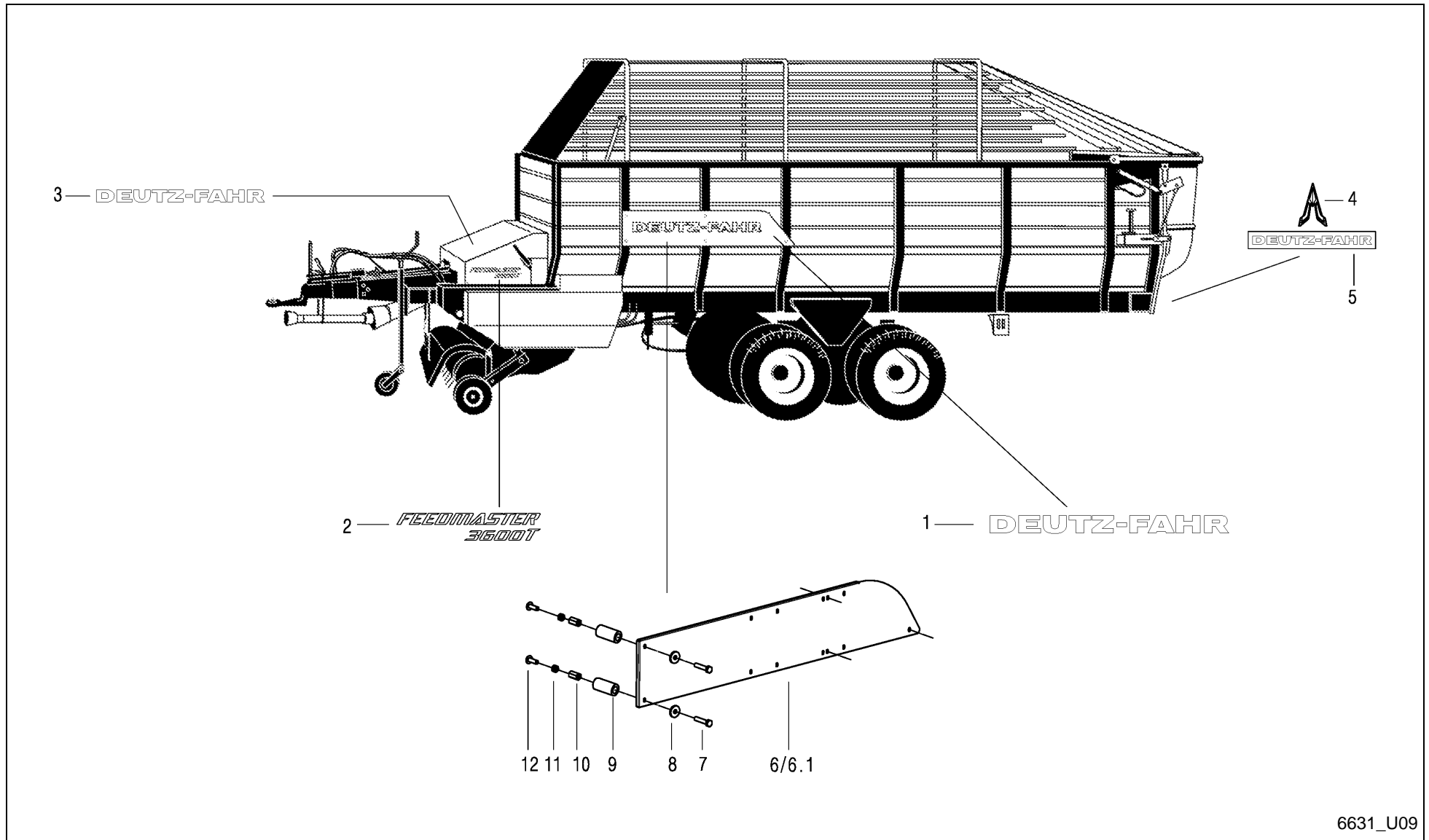

6631_U09

FeedMaster 3600T / DECALS



PosNo.	Part No.	Qty.	Description	Remark
1	A143016674	2	STICKER DEUTZ-FAHR SMALL	
2	A143041874	2	STICKER FEEDMASTER 3600 T	
3	A143018174	1	STICKER DF-LARGE 15	
4	A143016974	1	STICKER LOGO DF 1	
5	A143016874	1	STICKER DF-SMALL 15	
6	A143017086	1	SHEET 1 LEFT	
6.1	A143017186	1	SHEET 2 RIGHT	
7	VF01112356	10	BOLT M8X40 ISO4017 8.8 A3C (D933)	
8	VF06214192	10	WASHER 8,4X25X3 GALV.	
9	A143017286	10	SPACER TUBE	
10	A143017300	10	EXTENSION NUT	
11	VF01104944	10	NY LOCK NUT 8A3CD985	
12	VF01142856	10	CUP SQR. BOLT M8X25DIN7380-2 10.9 GALV.	

FeedMaster 3600T / Part No Index



Part No.	Page	Pos No	Part No.	Page	Pos No	Part No.	Page	Pos No	Part No.	Page	Pos No
A10000300	4	14	A143031730	85	1	A143467500	56	451	A143504700	21	65
A10000300	5	14	A143031880	88	27	A143472600	21	63	A143504700	22	46
A143012000	42	1	A143031980	88	31	A143472600	22	50	A143504800	21	66
A143012100	42	2	A143032180	44	47	A143472600	56	448	A143504900	21	67
A143012200	42	3	A143032180	45	47	A143475200	19	61	A143504900	22	51
A143012300	42	4	A143032280	44	48	A143475200	20	61	A143505000	21	68
A143012400	42	5	A143032280	45	48	A143485300	56	438	A143505000	22	48
A143012500	42	6	A143032380	45	49.1	A143485400	21	23	A143505200	21	69
A143012600	42	7	A143032480	45	49.2	A143485400	22	23	A143505200	22	47
A143012700	42	8	A143032580	45	50.1	A143501400	32	23.2	A143505500	21	71
A143012800	42	9	A143032680	45	50.2	A143501900	5	16	A143505500	22	60
A143012900	42	10	A143032780	44	51	A143502000	4	16	A143505800	21	77
A143013000	42	11	A143032780	45	51	A143502900	20	1	A143505800	22	63
A143013100	42	12	A143032880	44	52	A143503000	19	28	A143505900	21	81
A143014300	12	14	A143032880	45	52	A143503000	20	28	A143505900	22	68
A143014600	12	13	A143032980	44	53	A143503100	19	38	A143506000	21	82A
A143014600	12	13.1	A143032980	45	53	A143503100	20	38	A143506100	21	84
A143015000	64	33.1	A143033080	44	54	A143503200	20	43	A143506100	22	84
A143016674	95	1	A143033080	45	54	A143503300	19	53	A143506200	21	91
A143016874	95	5	A143037800	12	15	A143503300	20	53	A143506200	22	91
A143016974	95	4	A143037800	12	15.1	A143503400	19	59	A143506300	21	1
A143017086	95	6	A143039786	10	15	A143503400	20	59	A143506400	21	26
A143017186	95	6.1	A143039830	18	1	A143503600	19	72	A143506400	22	26
A143017286	95	9	A143041874	95	2	A143503600	20	72	A143506500	21	52
A143017300	95	10	A143047286	79	20	A143503700	19	92	A143506500	22	52
A143018174	95	3	A143047563	83	18	A143503700	20	92	A143506600	21	53
A143019674	94	5	A143047563	84	18	A143503800	21	96	A143506600	22	53
A143019774	94	11	A143047563	85	18	A143503800	22	96	A143506700	22	1
A143030430	69	1	A143458700	21	75	A143503800	23	96	A143506800	22	22
A143031580	46	44	A143458700	22	65	A143504300	21	60	A143506900	22	57
A143031663	11	26	A143459000	21	62	A143504300	22	55	A143507000	22	58
A143031730	80	1	A143466900	56	437	A143504400	21	61	A143507100	23	91
A143031730	82	1	A143466900	56	450	A143504500	21	64	A143507200	23	1

FeedMaster 3600T / Part No Index



Part No.	Page	Pos No	Part No.	Page	Pos No	Part No.	Page	Pos No	Part No.	Page	Pos No
A143507300	19	1	KG00742063	5	52	VF01102701	43	18	VF01104944	46	36
A143507400	19	43	KG01184962	24	11	VF01102796	61	22	VF01104944	47	16
A143507600	21	25	KG01184962	25	11	VF01102797	40	3	VF01104944	48	29
A143507600	22	25	KG01185862	17	5	VF01102797	41	3	VF01104944	49	4
A143507700	21	32	KG01194500	4	27	VF01102797	42	15	VF01104944	50	8
A143507700	22	32	KG01194500	5	27	VF01102797	47	61	VF01104944	52	11
A143507700	23	32	KG01248161	55	17	VF01102797	61	14	VF01104944	54	11
A143517100	56	473	KG01273861	33	1	VF01102799	2	29	VF01104944	60	3
A143517400	56	400	KG01273861	72	45	VF01102799	57	8	VF01104944	63	23
A143517500	56	414	VF01001718	51	15	VF01102799	63	28	VF01104944	64	45
A143517600	56	414A	VF01097625	54	21	VF01102799	88	1	VF01104944	65	13
A143517700	56	416	VF01100233	34	21	VF01102800	2	23	VF01104944	65	7
A143517800	56	417	VF01100590	52	19	VF01102800	3	17	VF01104944	67	7
A143517900	56	422	VF01100590	54	22	VF01102800	29	16	VF01104944	68	29
A143518000	56	472	VF01100600	24	16	VF01102800	79	17	VF01104944	69	29
A143518100	56	424	VF01100600	25	16	VF01103117	39	7	VF01104944	70	7
A143518200	56	425	VF01100982	40	30	VF01103316	27	23	VF01104944	73	7
A143518300	56	433	VF01100982	41	34	VF01103316	39	9	VF01104944	74	8
A143518400	56	435	VF01100982	42	25	VF01103316	44	80	VF01104944	76	3
A143518500	56	436	VF01101288	24	18	VF01103316	49	11	VF01104944	77	3
A143518600	56	440	VF01101288	25	18	VF01103316	61	16	VF01104944	78	3
A143518700	56	442	VF01101405	92	20	VF01103316	88	17	VF01104944	79	23
A143518800	56	446	VF01101596	7	11	VF01103341	24	21	VF01104944	88	2
A143518900	56	447	VF01101596	9	8	VF01103341	25	21	VF01104944	92	27
A143519000	56	449	VF01101600	59	17.1	VF01103341	28	2	VF01104944	95	11
A143519100	56	470	VF01102550	61	5	VF01103341	38	13	VF01105524	61	7
A143519200	56	471	VF01102659	8	19	VF01104944	12	22	VF01105526	61	21
KG00357500	15	14	VF01102659	11	30	VF01104944	29	22	VF01105544	63	13
KG00358261	87	12	VF01102659	46	27	VF01104944	34	10	VF01105571	60	35
KG00476561	4	13	VF01102659	57	12	VF01104944	39	20	VF01105593	88	36
KG00476561	5	13	VF01102659	91	17	VF01104944	43	4	VF01106447	13	5
KG00480461	1	15	VF01102659	92	26	VF01104944	44	19	VF01106447	34	3
KG00742063	4	52	VF01102664	27	26	VF01104944	45	6	VF01106451	11	24

FeedMaster 3600T / Part No Index



Part No.	Page	Pos No	Part No.	Page	Pos No	Part No.	Page	Pos No	Part No.	Page	Pos No
VF01106451	24	9	VF01107165	16	5	VF01109044	3	13	VF01111339	16	2
VF01106451	25	9	VF01107165	29	24	VF01109057	3	12	VF01111352	29	18
VF01106451	32	29	VF01107165	63	20	VF01109063	2	14	VF01111475	11	38
VF01106451	33	7	VF01107165	65	12	VF01109886	17	13	VF01111486	16	27
VF01106451	38	3	VF01107165	66	38	VF01109958	2	15	VF01111504	55	30
VF01106451	46	3	VF01107165	72	38	VF01109960	86	11	VF01111514	46	5
VF01106451	49	6	VF01107165	79	13	VF01109962	86	4	VF01111522	91	16
VF01106451	55	35	VF01107165	88	11	VF01110001	7	12	VF01111527	46	22
VF01106451	57	29	VF01107165	92	33	VF01110001	9	7	VF01111562	11	15
VF01106451	91	12	VF01107726	64	18	VF01110002	2	16	VF01111576	50	4
VF01106451	92	17	VF01107726	68	14	VF01110415	2	17	VF01111861	11	5
VF01106500	36	6	VF01107726	69	14	VF01110415	3	20	VF01111867	52	10
VF01106500	58	12	VF01107737	1	6	VF01110577	63	14	VF01111867	54	10
VF01107095	47	60	VF01107742	64	19	VF01111071	16	18	VF01111941	18	2
VF01107095	62	5	VF01107742	68	19	VF01111071	24	25	VF01112240	59	25
VF01107095	88	77	VF01107742	69	19	VF01111071	25	25	VF01112240	88	6
VF01107101	55	16	VF01107755	1	28	VF01111071	62	4	VF01112264	31	22
VF01107103	31	9	VF01107760	64	20	VF01111079	88	4	VF01112264	33	70
VF01107105	47	44	VF01107792	66	63	VF01111083	49	18	VF01112264	61	26
VF01107105	57	11	VF01107792	72	63	VF01111136	71	21	VF01112264	63	18
VF01107121	32	28	VF01107838	67	4	VF01111153	88	5	VF01112264	71	28
VF01107158	62	16	VF01107838	73	4	VF01111168	37	14	VF01112264	88	78
VF01107163	29	23	VF01107855	2	13	VF01111179	60	5	VF01112307	2	26
VF01107163	37	15	VF01107858	80	8	VF01111184	64	26	VF01112307	17	7
VF01107163	44	86	VF01107858	81	8	VF01111184	68	7	VF01112307	53	11
VF01107163	48	52	VF01107858	82	8	VF01111184	69	7	VF01112307	63	32
VF01107163	49	5	VF01108524	47	79	VF01111298	44	4	VF01112307	71	35
VF01107163	60	2	VF01108524	65	16	VF01111298	63	16	VF01112307	88	7
VF01107163	63	27	VF01108524	67	12	VF01111298	66	36	VF01112322	34	9
VF01107163	71	26	VF01108524	70	16	VF01111308	15	12	VF01112322	48	51
VF01107163	76	15	VF01108524	73	12	VF01111315	72	36	VF01112322	63	31
VF01107163	77	15	VF01108981	3	11	VF01111325	8	16	VF01112322	74	6
VF01107163	78	15	VF01108982	64	21	VF01111336	57	10	VF01112322	76	19

FeedMaster 3600T / Part No Index



Part No.	Page	Pos No	Part No.	Page	Pos No	Part No.	Page	Pos No	Part No.	Page	Pos No
VF01112322	77	19	VF01112429	44	6	VF01112529	15	10	VF01112886	21	101
VF01112322	78	19	VF01112429	45	2	VF01112529	75	30	VF01112886	22	101
VF01112322	88	5	VF01112429	45	30	VF01112538	1	38	VF01112886	79	11
VF01112333	44	45	VF01112429	66	20	VF01112538	13	7	VF01112916	75	13
VF01112333	45	29	VF01112429	71	17	VF01112538	14	14	VF01112972	58	1
VF01112333	46	41	VF01112429	72	20	VF01112538	76	10	VF01114357	16	19
VF01112333	48	31	VF01112429	75	15	VF01112538	77	10	VF01114357	24	26
VF01112333	52	7	VF01112429	76	9	VF01112538	78	10	VF01114357	25	26
VF01112333	54	7	VF01112429	77	9	VF01112683	51	4	VF01114357	26	10
VF01112333	57	7	VF01112429	78	9	VF01112683	54	9	VF01114357	27	3
VF01112333	66	43	VF01112429	88	10	VF01112687	52	9	VF01114357	30	56
VF01112333	72	43	VF01112429	92	21	VF01112687	53	12	VF01114357	31	23
VF01112333	87	13	VF01112439	16	3	VF01112687	80	23	VF01114357	32	17
VF01112341	39	19	VF01112439	27	27	VF01112687	81	23	VF01114357	33	41
VF01112341	44	81	VF01112439	28	20	VF01112687	82	23	VF01114357	39	10
VF01112341	45	4	VF01112439	29	4	VF01112709	79	9	VF01114357	44	66
VF01112341	47	25	VF01112439	88	81	VF01112803	61	23	VF01114357	45	17
VF01112341	50	6	VF01112439	89	1	VF01112824	17	8	VF01114357	49	19
VF01112350	57	13	VF01112439	90	1	VF01112824	37	18	VF01114357	61	19
VF01112356	95	7	VF01112439	91	13	VF01112824	53	14	VF01114357	61	28
VF01112407	79	7	VF01112439	92	22	VF01112824	57	14	VF01114357	62	17
VF01112407	88	13	VF01112447	27	33	VF01112824	71	41	VF01114357	63	22
VF01112418	29	17	VF01112447	51	11	VF01112824	74	11	VF01114357	71	30
VF01112418	31	7	VF01112447	77	21	VF01112824	87	16	VF01114357	79	15
VF01112418	44	46	VF01112447	78	21	VF01112850	11	29	VF01114357	88	12
VF01112418	45	11	VF01112451	71	33	VF01112858	8	8	VF01114357	88	79
VF01112418	52	8	VF01112451	91	14	VF01112858	13	2	VF01114357	89	7
VF01112418	54	8	VF01112451	92	23	VF01112886	1	16	VF01114357	90	7
VF01112418	63	21	VF01112476	91	15	VF01112886	6	12	VF01115021	46	21
VF01112418	71	13	VF01112476	92	24	VF01112886	8	20	VF01115438	58	11
VF01112429	2	18	VF01112529	1	33	VF01112886	11	11	VF01115441	63	15
VF01112429	14	12	VF01112529	13	8	VF01112886	19	101	VF01115441	71	38
VF01112429	27	1	VF01112529	14	16	VF01112886	20	101	VF01115457	17	14

FeedMaster 3600T / Part No Index



Part No.	Page	Pos No	Part No.	Page	Pos No	Part No.	Page	Pos No	Part No.	Page	Pos No
VF01115457	66	10	VF01116946	81	29	VF01120923	13	3	VF01124703	66	27
VF01115457	72	10	VF01116946	82	29	VF01121766	26	23	VF01124703	72	27
VF01115460	66	3	VF01118100	75	23	VF01121766	28	11	VF01125146	26	5
VF01115478	52	14	VF01118111	75	25	VF01121797	11	40	VF01125146	27	6
VF01115478	53	17	VF01118645	59	26	VF01121808	11	41	VF01125146	28	7
VF01115478	54	14	VF01118675	37	19	VF01121824	31	4	VF01125152	26	18
VF01115478	75	22	VF01118699	27	39	VF01121824	36	9	VF01125152	27	29
VF01116622	32	21	VF01118699	29	8	VF01122071	19	62	VF01125801	16	24
VF01116622	33	72	VF01118736	26	12	VF01122071	20	62	VF01126049	88	14
VF01116622	34	1	VF01118736	27	4	VF01122072	11	21	VF01126186	93	4
VF01116622	35	49	VF01118736	28	5	VF01122072	16	23	VF01126332	38	27
VF01116622	36	12	VF01118736	29	3	VF01122072	32	24	VF01126332	92	31
VF01116622	37	28	VF01119806	49	15	VF01122072	46	15	VF01126929	3	16
VF01116622	38	19	VF01120613	86	14	VF01122072	47	19	VF01126974	26	15
VF01116622	39	41	VF01120671	86	15	VF01122072	92	18	VF01127346	32	22
VF01116626	26	17	VF01120692	8	15	VF01122389	26	9	VF01127346	33	74
VF01116626	27	31	VF01120692	11	17	VF01122389	27	5	VF01127346	34	14
VF01116626	30	62	VF01120692	46	47	VF01122389	30	55	VF01127346	35	48
VF01116653	30	63	VF01120692	53	25	VF01122389	40	2	VF01127346	36	11
VF01116705	32	2	VF01120692	75	24	VF01122389	41	2	VF01127346	37	29
VF01116705	34	16	VF01120693	17	11	VF01122389	42	14	VF01127346	38	18
VF01116705	38	20	VF01120693	40	26	VF01123290	11	27	VF01127346	39	42
VF01116708	24	13	VF01120693	41	30	VF01123749	32	18	VF01127538	44	5
VF01116708	25	13	VF01120693	42	21	VF01123749	47	59	VF01127538	45	3
VF01116710	30	44	VF01120694	10	9	VF01123863	66	12	VF01127538	65	15
VF01116731	32	7	VF01120696	80	27	VF01123863	72	12	VF01127538	66	19
VF01116740	32	4	VF01120696	81	27	VF01123941	31	3	VF01127538	67	11
VF01116740	33	62	VF01120696	82	27	VF01123941	36	8	VF01127538	70	15
VF01116740	34	15	VF01120697	83	8	VF01124441	3	21	VF01127538	71	19
VF01116740	35	12	VF01120697	84	8	VF01124633	24	14	VF01127538	72	19
VF01116740	39	26	VF01120697	85	8	VF01124633	25	14	VF01127538	73	11
VF01116758	30	37	VF01120700	86	24	VF01124633	46	33	VF01127538	76	13
VF01116946	80	29	VF01120915	11	28	VF01124663	86	27	VF01127538	77	13

FeedMaster 3600T / Part No Index



Part No.	Page	Pos No	Part No.	Page	Pos No	Part No.	Page	Pos No	Part No.	Page	Pos No
VF01127538	78	13	VF01136762	73	3	VF01138951	87	14	VF01141391	35	37
VF01127538	91	20	VF01136763	64	22	VF01138989	44	65	VF01141455	47	76
VF01127538	93	5	VF01136930	36	16	VF01138989	45	15	VF01141838	35	36
VF01127856	10	19	VF01136930	58	7	VF01138989	79	6	VF01142006	30	35
VF01127856	11	8	VF01137130	86	26.2	VF01139169	14	6	VF01142023	28	24
VF01127856	17	21	VF01137252	87	9	VF01139169	15	6	VF01142049	93	7
VF01127856	18	3	VF01137321	2	11	VF01139169	16	15	VF01142077	32	16
VF01127856	51	5	VF01137321	80	19	VF01139339	17	18	VF01142083	26	22
VF01127856	52	13	VF01137321	81	19	VF01139339	83	12	VF01142083	28	12
VF01127856	53	15	VF01137321	82	19	VF01139339	85	12	VF01142086	80	7
VF01127856	54	13	VF01137379	1	29	VF01139468	11	23	VF01142086	81	7
VF01127856	80	25	VF01137379	2	20	VF01139468	38	28	VF01142086	82	7
VF01127856	81	25	VF01137526	52	15	VF01139468	46	10	VF01142213	71	16
VF01127856	82	25	VF01137526	53	20	VF01139650	93	6	VF01142246	29	9
VF01128192	60	42	VF01137526	54	15	VF01139722	43	21	VF01142247	26	13
VF01128266	39	27	VF01137624	12	20	VF01139735	86	21	VF01142247	27	8
VF01128272	1	35	VF01137628	47	48	VF01140002	7	10	VF01142247	29	6
VF01131116	34	5	VF01137628	65	6	VF01140002	9	6	VF01142492	1	17
VF01132262	49	13	VF01137628	67	6	VF01141006	34	8	VF01142556	2	32
VF01132294	62	14	VF01137628	70	6	VF01141006	88	16	VF01142556	10	17
VF01132621	46	30	VF01137628	73	6	VF01141047	17	10	VF01142556	11	6
VF01132625	11	33	VF01137633	27	37	VF01141112	71	24	VF01142556	52	18
VF01133784	89	8	VF01137633	29	7	VF01141112	88	15	VF01142556	54	18
VF01133784	90	8	VF01137633	30	40	VF01141159	80	20	VF01142565	39	30
VF01133798	6	7	VF01137837	16	7	VF01141159	81	20	VF01142565	44	59
VF01133922	30	38	VF01137990	86	8	VF01141159	82	20	VF01142565	45	26
VF01135950	61	6	VF01138374	64	34	VF01141235	39	4	VF01142565	46	35
VF01136666	53	10	VF01138374	68	6	VF01141295	36	3	VF01142565	76	2
VF01136686	14	3	VF01138374	69	6	VF01141296	36	2	VF01142565	77	2
VF01136686	15	3	VF01138374	92	32	VF01141364	66	24	VF01142565	78	2
VF01136686	16	16	VF01138412	92	30	VF01141364	72	24	VF01142565	79	21
VF01136687	16	9	VF01138686	64	36.1	VF01141365	66	26	VF01142565	88	21
VF01136762	67	3	VF01138951	71	40	VF01141365	72	26	VF01142641	36	7

FeedMaster 3600T / Part No Index



Part No.	Page	Pos No	Part No.	Page	Pos No	Part No.	Page	Pos No	Part No.	Page	Pos No
VF01142796	80	24	VF01157338	72	13	VF01175657	86	16	VF01397859	3	18
VF01142796	81	24	VF01157344	34	19	VF01177316	39	5	VF01397863	64	28
VF01142796	82	24	VF01157344	66	11	VF01177466	91	25	VF01397863	68	8
VF01142805	65	5	VF01157344	72	11	VF01177810	2	31	VF01397863	69	8
VF01142805	70	5	VF01157344	92	29	VF01177887	3	23	VF01397870	61	3
VF01142806	65	3	VF01157345	36	17	VF01177888	2	33	VF01397871	61	4
VF01142806	70	3	VF01157345	58	8	VF01178250	67	17	VF01397896	59	19
VF01142826	88	19	VF01157348	64	29	VF01178250	73	17	VF01397896	60	8
VF01142841	80	31	VF01157348	68	16	VF01211882	27	24	VF01397920	59	20
VF01142841	81	31	VF01157348	69	16	VF01211882	39	2	VF01397920	60	20
VF01142841	82	31	VF01157381	80	26	VF01292484	40	31	VF01397931	65	14
VF01142841	83	17	VF01157381	81	26	VF01292484	41	35	VF01397931	67	10
VF01142841	84	17	VF01157381	82	26	VF01292484	42	26	VF01397931	70	14
VF01142841	85	17	VF01157382	64	30	VF01397550	59	4	VF01397931	73	10
VF01142856	47	49	VF01157382	68	15	VF01397555	36	14	VF01397933	40	27
VF01142856	95	12	VF01157382	69	15	VF01397575	3	14	VF01397933	41	31
VF01142889	59	18	VF01163589	40	25	VF01397576	3	10	VF01397933	42	22
VF01142958	74	2	VF01163589	41	29	VF01397597	58	14	VF01403239	59	21
VF01142993.01	1	18	VF01163589	42	20	VF01397598	39	25	VF01404321	60	46
VF01143009	92	19	VF01164017	59	12	VF01397598	60	50	VF02953340	64	23
VF01143017	59	14	VF01167577	72	28	VF01397605	12	12	VF02953368	27	38
VF01143083	39	18	VF01167953	35	30	VF01397605	12	12.1	VF02953368	29	11
VF01143090	83	16	VF01167956	35	31	VF01397609	65	9	VF02953369	26	16
VF01143090	85	16	VF01169436	49	21	VF01397609	67	9	VF02953369	27	30
VF01143097	59	5	VF01169581	37	3	VF01397609	70	9	VF02953408	60	34
VF01143103	37	17	VF01169697	79	10	VF01397609	73	9	VF02953409	60	32
VF01143104	32	13	VF01172407	2	19	VF01397661	10	12	VF02953410	60	41
VF01143104	37	20	VF01173381	64	25	VF01397704	60	33	VF03.110.02.140	16	21
VF01151892	59	16	VF01173381	71	34	VF01397760	40	24	VF03.110.02.140	19	60
VF01151892	60	16	VF01173639	35	32	VF01397760	41	28	VF03.110.02.140	20	60
VF01157337	47	20	VF01173914	66	15	VF01397760	42	19	VF04308511	61	9
VF01157337	75	21	VF01173914	71	18	VF01397770	30	2	VF06205968	47	50
VF01157338	66	13	VF01173914	72	15	VF01397855	62	8	VF06207186	16	20

FeedMaster 3600T / Part No Index



Part No.	Page	Pos No	Part No.	Page	Pos No	Part No.	Page	Pos No	Part No.	Page	Pos No
VF06207534	43	3	VF06209768	15	13	VF06209769	16	29	VF06212426	68	22
VF06207534	44	18	VF06209768	16	10	VF06209769	24	22	VF06212426	69	22
VF06207534	45	14	VF06209768	27	9	VF06209769	25	22	VF06212435	64	32
VF06207534	47	14	VF06209768	28	16	VF06209769	46	6	VF06213664	58	15
VF06207535	43	6	VF06209768	29	5	VF06209769	50	5	VF06213700	74	9
VF06207535	44	21	VF06209768	31	8	VF06209769	75	19	VF06213737	59	15
VF06207535	49	3	VF06209768	44	16	VF06209769	76	12	VF06213973	61	15
VF06207535	65	11	VF06209768	45	13	VF06209769	77	12	VF06213974	62	10
VF06207557	79	14	VF06209768	46	38	VF06209769	78	12	VF06213977	61	2
VF06208913	64	24	VF06209768	51	13	VF06209769	87	17	VF06213982	62	18
VF06208913	68	21	VF06209768	52	12	VF06209769	91	18	VF06214036	88	35
VF06208913	69	21	VF06209768	54	12	VF06209774	10	8	VF06214037	88	26
VF06208934	86	6	VF06209768	63	24	VF06209774	17	17	VF06214041	61	20
VF06208962	87	11	VF06209768	66	21	VF06209774	53	16	VF06214045	60	6
VF06209168	10	7	VF06209768	66	39	VF06209778	11	3	VF06214156	30	53
VF06209245	79	18	VF06209768	71	14	VF06209778	28	4	VF06214189	24	27
VF06209249	43	7	VF06209768	72	21	VF06209778	38	14	VF06214189	25	27
VF06209411	75	14	VF06209768	72	39	VF06209778	43	8	VF06214189	26	11
VF06209459	76	8	VF06209768	75	18	VF06209919	55	36	VF06214189	27	10
VF06209459	77	8	VF06209768	75	20	VF06209952	11	18	VF06214189	44	67
VF06209459	78	8	VF06209768	76	11	VF06210000	55	15	VF06214189	45	16
VF06209459	79	8	VF06209768	77	11	VF06210009	11	31	VF06214189	49	10
VF06209465	47	45	VF06209768	78	11	VF06210014	13	4	VF06214189	49	20
VF06209473	53	13	VF06209768	79	12	VF06210014	34	2	VF06214189	61	27
VF06209476	63	19	VF06209768	88	18	VF06210015	25	28	VF06214189	63	26
VF06209476	71	22	VF06209768	89	2	VF06210015	57	27	VF06214189	71	29
VF06209484	75	16	VF06209768	90	2	VF06210017	24	10	VF06214189	79	16
VF06209580	35	28	VF06209768	91	19	VF06210017	25	10	VF06214189	88	3
VF06209764	49	14	VF06209768	92	28	VF06210032	46	2	VF06214189	88	38
VF06209765	61	8	VF06209769	1	34	VF06210033	66	8	VF06214192	43	5
VF06209765	62	15	VF06209769	13	9	VF06210033	72	8	VF06214192	44	20
VF06209765	88	37	VF06209769	14	15	VF06211876	53	23	VF06214192	45	5
VF06209768	14	13	VF06209769	15	16	VF06212426	64	31	VF06214192	46	37

FeedMaster 3600T / Part No Index



Part No.	Page	Pos No	Part No.	Page	Pos No	Part No.	Page	Pos No	Part No.	Page	Pos No
VF06214192	47	15	VF06214215	46	4	VF06214420	64	35	VF06215308	66	37
VF06214192	48	30	VF06214215	49	7	VF06214420	68	25	VF06215308	72	37
VF06214192	95	8	VF06214217	3	24	VF06214420	69	25	VF06215315	46	18
VF06214193	50	7	VF06214217	38	16	VF06214481	64	36	VF06215425	33	3
VF06214193	74	7	VF06214220	10	18	VF06214481	68	20	VF06215513	49	8
VF06214193	79	22	VF06214220	11	7	VF06214481	69	20	VF06215561	63	29
VF06214197	16	12	VF06214226	11	20	VF06214486	52	16	VF06215561	71	39
VF06214197	28	15	VF06214226	16	22	VF06214486	53	21	VF06215561	87	22
VF06214197	44	15	VF06214226	38	26	VF06214486	54	16	VF06215561	91	22
VF06214197	45	12	VF06214226	53	24	VF06214490	2	20	VF06215561	92	36
VF06214197	51	12	VF06214226	66	5	VF06214491	2	20	VF06215565	47	62
VF06214197	89	3	VF06214226	92	35	VF06214492	2	20	VF06215666	47	63
VF06214197	90	3	VF06214228	47	18	VF06214493	1	31	VF06215666	65	18
VF06214198	79	24	VF06214229	11	19	VF06214499	86	26.1	VF06215666	66	22
VF06214202	31	5	VF06214229	47	17	VF06214500	86	26	VF06215666	67	13
VF06214206	15	15	VF06214234	66	4	VF06214504	86	22	VF06215666	70	18
VF06214206	16	28	VF06214237	36	4	VF06214519	2	21	VF06215666	72	22
VF06214206	24	23	VF06214238	36	5	VF06214520	2	21	VF06215666	73	13
VF06214206	25	23	VF06214238	58	9	VF06214521	2	21	VF06215671	17	22
VF06214206	28	3	VF06214246	2	28	VF06214570	64	46	VF06216097	94	4
VF06214206	76	14	VF06214288	55	34	VF06214572	64	46.1	VF06216396	32	20
VF06214206	77	14	VF06214306	30	39	VF06214585	33	6	VF06216396	62	7
VF06214206	78	14	VF06214307	26	25	VF06214588	1	5	VF06216397	31	21
VF06214206	91	21	VF06214313	64	44	VF06214633	47	11	VF06216397	32	15
VF06214206	92	34	VF06214313	67	14	VF06214938	64	37	VF06216397	33	69
VF06214207	1	36	VF06214313	68	32	VF06214948	86	12	VF06216397	35	39
VF06214207	24	12	VF06214313	69	32	VF06214950	86	3	VF06216397	36	13
VF06214207	25	12	VF06214313	73	14	VF06214992	88	28	VF06216397	38	7
VF06214207	43	9	VF06214314	64	43	VF06215016	86	20	VF06216397	60	48
VF06214207	46	7	VF06214314	68	31	VF06215027	64	38	VF06216479	34	28
VF06214207	57	28	VF06214314	69	31	VF06215027	68	13	VF06216479	39	38
VF06214207	87	18	VF06214332	75	26	VF06215027	69	13	VF06216479	49	22
VF06214207	91	26	VF06214333	75	26.1	VF06215029	87	21	VF06216479	59	22

FeedMaster 3600T / Part No Index



Part No.	Page	Pos No	Part No.	Page	Pos No	Part No.	Page	Pos No	Part No.	Page	Pos No
VF06216479	60	22	VF06216815	40	23	VF06273759	82	30	VF06277517	85	15
VF06216479	61	13	VF06216815	41	27	VF06273759	83	9	VF06277518	83	14
VF06216479	62	12	VF06216815	42	18	VF06273759	84	9	VF06277518	85	14
VF06216480	34	26	VF06216836	30	51	VF06273759	85	9	VF06278720	91	23
VF06216480	62	13	VF06216854	40	17	VF06273763	80	21	VF06278720	92	5
VF06216527	40	21	VF06216854	41	20	VF06273763	81	21	VF06278838	61	12
VF06216527	41	26	VF06216854	42	16	VF06273763	82	21	VF06282196	64	2
VF06216527	42	17	VF06216908	24	15	VF06273771	80	22	VF06286217	38	1.1
VF06216527	80	10	VF06216908	25	15	VF06273771	81	22	VF06295430	2	8
VF06216527	81	10	VF06217046	35	46	VF06273771	82	22	VF06296264	63	2
VF06216527	82	10	VF06243750	92	1	VF06273854	71	15	VF06296264	71	6
VF06216527	83	10	VF06246795	64	4	VF06273871	86	10	VF06296285	64	5
VF06216527	84	10	VF06246795	68	10.1	VF06273872	86	5	VF06296285	68	4
VF06216527	85	10	VF06246795	69	10.1	VF06273873	83	3	VF06296285	69	4
VF06216745	28	22	VF06258500	32	19	VF06273873	84	3	VF06301830	64	3
VF06216747	28	19	VF06264206	47	56	VF06273873	85	3	VF06550287	75	28
VF06216756	27	34	VF06264206	51	9	VF06277296	26	4	VF06550405	1	37
VF06216756	28	25	VF06264206	91	11	VF06277296	27	13	VF06551690	39	3
VF06216756	29	1	VF06272542	3	15	VF06277296	28	6	VF06551694	39	22
VF06216757	26	21	VF06273686	75	17	VF06277296	29	10	VF06552196	75	29
VF06216757	27	12	VF06273756	83	2	VF06277504	43	17	VF06552906	76	18
VF06216757	28	18	VF06273756	84	2	VF06277504	66	41	VF06552906	77	18
VF06216757	29	2	VF06273756	85	2	VF06277504	72	41	VF06552906	78	18
VF06216762	27	35	VF06273759	6	10	VF06277504	87	4	VF06553944	83	13
VF06216762	28	8	VF06273759	8	21	VF06277509	83	6	VF06553944	84	13
VF06216763	26	24	VF06273759	10	16	VF06277509	84	6	VF06553944	85	13
VF06216763	27	32	VF06273759	11	10	VF06277509	85	6	VF06554188	2	6
VF06216763	28	17	VF06273759	19	100	VF06277514	87	23	VF06554451	39	37
VF06216771	26	1	VF06273759	20	100	VF06277516	64	41	VF06554525	53	3
VF06216772	26	2	VF06273759	21	100	VF06277516	68	26.2	VF06554678	25	1.2
VF06216772	28	10	VF06273759	22	100	VF06277516	69	26.2	VF06554790	52	1
VF06216773	39	6	VF06273759	80	30	VF06277517	83	15	VF06554790	53	19
VF06216815	39	1	VF06273759	81	30	VF06277517	84	15	VF06554790	54	1

FeedMaster 3600T / Part No Index



Part No.	Page	Pos No	Part No.	Page	Pos No	Part No.	Page	Pos No	Part No.	Page	Pos No
VF0655222	34	22	VF06564448	51	10	VF06571196	79	3	VF06576503	33	4
VF06556268	52	3.1	VF06564448	58	13	VF06571198	79	2	VF06576507	34	25
VF06556619	57	37	VF06564448	91	1	VF06571205	86	2	VF06576830	66	16
VF06556728	87	8	VF06564733	66	1	VF06571309	64	10	VF06576830	72	16
VF06556744	66	23	VF06564733	72	1	VF06571309	68	9.1	VF06577030	75	11
VF06556744	72	23	VF06564735	66	25	VF06571309	69	9.1	VF06577064	75	3
VF06556821	88	23	VF06564735	72	25	VF06571314	64	40	VF06577068	61	11
VF06556826.80	88	24	VF06567492	66	28	VF06571314	68	27	VF06577095	43	13
VF06556888	1	39	VF06567492	72	30	VF06571314	69	27	VF06577097	43	11
VF06557524	9	13	VF06567493	66	29	VF06571321	64	11	VF06577109	91	2
VF06557587	2	10	VF06570007	86	13	VF06571322	63	4	VF06577109	92	2
VF06558198	66	35	VF06570185	92	15	VF06571322	71	31	VF06577110	91	3
VF06558198	72	35	VF06570195	92	14	VF06571323	63	6	VF06577110	92	3
VF06558560	53	5	VF06570724	93	1	VF06571323	71	32	VF06577111	91	4
VF06558561	53	6	VF06570740	93	2	VF06571325	79	19	VF06577111	92	4
VF06558562	53	7	VF06570914	86	7	VF06571330	30	61	VF06577152	47	13
VF06558565	54	4	VF06570920	63	9	VF06571331	38	11	VF06577154	47	12
VF06558567	52	5	VF06570925	74	1	VF06571341	30	36	VF06577181	47	77
VF06558567	54	5	VF06571004	64	7	VF06571341	31	2	VF06577182	47	78
VF06558569	53	8	VF06571005	63	7	VF06571355	63	30	VF06577183	47	46
VF06558571	51	8	VF06571018	38	5	VF06572448	44	79	VF06577184	48	32
VF06558644	75	10	VF06571032	86	1	VF06572550	51	7	VF06577192	47	75
VF06558728	16	13	VF06571033	86	25	VF06575213	39	24	VF06577238	43	1
VF06558733	16	11	VF06571090	63	12	VF06575216	39	43	VF06577240	43	2
VF06558801	26	14	VF06571094	63	10	VF06575217	39	44	VF06577242	43	12
VF06558917	14	2	VF06571099	63	11	VF06575227	2	34	VF06577305	86	9
VF06558917	15	2	VF06571134	63	3	VF06575227	52	6	VF06577317	80	5
VF06558937	79	1	VF06571148	64	42	VF06575227	54	6	VF06577317	81	5
VF06558991	26	3	VF06571150	80	11	VF06575228	51	3	VF06577317	82	5
VF06558992	28	9	VF06571150	81	11	VF06575231	1	1	VF06577328	83	11
VF06559244	64	14	VF06571150	82	11	VF06575248	2	30	VF06577335	80	14
VF06562016	91	28	VF06571172	91	8	VF06575249	2	30	VF06577335	81	14
VF06564448	47	57	VF06571186	92	11	VF06575250	2	30	VF06577335	82	14

FeedMaster 3600T / Part No Index



Part No.	Page	Pos No	Part No.	Page	Pos No	Part No.	Page	Pos No	Part No.	Page	Pos No
VF06577348	87	1	VF06577521	88	34	VF06578868	80	16	VF06586171	4	12
VF06577349	87	2	VF06577562	43	19	VF06578868	81	16	VF06586171	5	12
VF06577374	83	1	VF06577563	43	20	VF06578868	82	16	VF06586755	4	24
VF06577385	87	7	VF06577567	32	10	VF06578892	91	24	VF06586755	5	24
VF06577387	66	40	VF06577579	76	7	VF06578934	65	4	VF06587052	59	13
VF06577387	72	40	VF06577579	77	7	VF06578934	70	4	VF06587227	57	38
VF06577389	79	4	VF06577579	78	7	VF06578978	2	24	VF06587235	53	9
VF06577391	79	5	VF06577583	91	7	VF06578992	47	73	VF06587374	48	28
VF06577397	64	6	VF06577584	38	9	VF06578993	47	74	VF06587375	48	27
VF06577405	63	5	VF06577586	92	9	VF06579237	44	64	VF06587559	83	4
VF06577406	64	8	VF06577864	33	63	VF06579237	45	28	VF06587559	84	4
VF06577407	64	9	VF06577918	89	5	VF06579350	88	25	VF06587559	85	4
VF06577420	66	18	VF06577919	89	6	VF06579358	86	23	VF06587560	66	42
VF06577420	72	18	VF06577968	75	27	VF06579491	38	23	VF06587560	72	42
VF06577421	66	17	VF06577987	34	6	VF06579959	59	2	VF06587560	87	5
VF06577421	72	17	VF06578035	16	17	VF06579960	59	3	VF06587590	38	1
VF06577422	66	14	VF06578035	24	24	VF06579961	59	17	VF06587598	75	6
VF06577422	72	14	VF06578035	25	24	VF06579979	59	10	VF06587602	75	5
VF06577423	65	10	VF06578035	26	8	VF06579981	60	42.1	VF06587631	16	6
VF06577426	63	8	VF06578035	27	20	VF06579982	60	42.2	VF06587659	24	3
VF06577432	64	17.1	VF06578035	30	57	VF06580174	1	7	VF06587672	48	40
VF06577432	68	26.1	VF06578349	75	2	VF06580546	72	29	VF06587674	48	39
VF06577432	69	26.1	VF06578608	34	17	VF06581181	33	71	VF0905191000	63	25
VF06577442	91	5	VF06578609	34	18	VF06581181	38	4	VF0905191000	71	15.1
VF06577442	92	6	VF06578611	34	4	VF06581494	43	10	VF11439109110	2	9
VF06577469	38	12	VF06578645	35	27	VF06581954	4	54	VF16503935	21	82
VF06577483	92	7	VF06578646	48	33	VF06581954	5	54	VF16503935	22	68A
VF06577489	92	10	VF06578650	34	23	VF06582340	4	26	VF16503949	8	6
VF06577494	92	12	VF06578651	34	24	VF06582340	5	26	VF16503949	21	72
VF06577496	91	10	VF06578750	75	4	VF06582524	31	1	VF16503949	22	72
VF06577496	92	13	VF06578761	75	7	VF06582530	31	1	VF16504079	33	5
VF06577498	92	16	VF06578826	75	8	VF06584800	35	26	VF16511004	36	1.1
VF06577514	88	33	VF06578830	38	10	VF06585321	2	2	VF16511031	74	10

FeedMaster 3600T / Part No Index



Part No.	Page	Pos No	Part No.	Page	Pos No	Part No.	Page	Pos No	Part No.	Page	Pos No
VF16511336	91	6	VF16513605	4	30	VF16515089	85	1	VF16515918	45	41
VF16511337	92	8	VF16513605	5	30	VF16515159	36	15	VF16515920	44	42
VF16511469	59	27	VF16513607	3	2.1	VF16515159	58	6	VF16515920	45	42
VF16511469	60	15	VF16513616	4	53	VF16515167	80	6	VF16515926	43	22
VF16511577	43	14	VF16513616	5	53	VF16515167	81	6	VF16515927	43	23
VF16511632	49	2	VF16513618	4	56	VF16515167	82	6	VF16515928	44	3
VF16511633	49	9	VF16513618	5	56	VF16515168	80	9	VF16515928	45	55
VF16511646	11	37	VF16513621	3	5	VF16515168	81	9	VF16515938	46	1
VF16512287	62	1	VF16513622	3	6	VF16515168	82	9	VF16515959	46	40
VF16512621	12	11	VF16513624	3	8	VF16515251	52	3	VF16515976	32	25
VF16512621	12	11.1	VF16513677	28	21	VF16515428	30	33	VF16515977	61	17
VF16512812	34	6	VF16513686	15	7	VF16515446	60	38	VF16515987	32	26
VF16513000	1	27	VF16513859	14	5	VF16515448	60	39	VF16515988	46	42
VF16513003	1	30	VF16513859	15	5	VF16515453	59	11	VF16516319	44	11
VF16513217	1	3	VF16513860	14	9	VF16515468	59	24	VF16516320	44	13
VF16513246	53	1	VF16513861	14	11	VF16515591	39	31	VF16516330	61	1
VF16513250	63	1	VF16513869	24	20	VF16515593	39	33	VF16516333	61	18
VF16513250	64	1	VF16513869	25	20	VF16515605	50	1	VF16516335	62	6
VF16513257	10	5	VF16513900	24	7	VF16515613	50	3	VF16516337	62	9
VF16513259	10	14	VF16513900	25	7	VF16515614	50	2	VF16516363	11	13
VF16513298	64	12	VF16513933	59	27.1	VF16515716	51	1	VF16516368	11	16
VF16513298	68	9	VF16513942	59	23	VF16515739	62	11	VF16516374	11	22
VF16513298	69	9	VF16513948	30	34	VF16515748	74	4	VF16516380	11	14
VF16513299	64	13	VF16513977	81	15	VF16515749	74	5	VF16516382	14	7
VF16513299	68	10	VF16514101	17	12	VF16515750	74	3	VF16516398	11	36
VF16513299	69	10	VF16514201	66	9	VF16515751	75	9	VF16516399	44	17
VF16513473	65	8	VF16514201	72	9	VF16515902	43	15	VF16516404	44	1
VF16513473	67	8	VF16514460	62	2	VF16515904	43	16	VF16516426	24	4
VF16513473	70	8	VF16514462	49	12	VF16515915	44	49	VF16516426	25	4
VF16513473	73	8	VF16514629	33	5	VF16515915	45	49	VF16516440	15	9
VF16513522	28	1	VF16515017	7	4	VF16515917	44	50	VF16516441	15	11
VF16513601	4	15	VF16515017	9	12	VF16515917	45	50	VF16516442	15	17
VF16513601	5	15	VF16515089	84	1	VF16515918	44	41	VF16516442	16	26

FeedMaster 3600T / Part No Index



Part No.	Page	Pos No	Part No.	Page	Pos No	Part No.	Page	Pos No	Part No.	Page	Pos No
VF16516500	11	25	VF16516705	40	10	VF16517499	66	7	VF16602597	22	29
VF16516507	14	1	VF16516706	40	12	VF16517499	72	7	VF16602597	23	29
VF16516507	15	1	VF16516707	40	13	VF16517792	60	31	VF16602598	21	33
VF16516512	11	34	VF16516708	40	14	VF16517917	60	40	VF16602598	22	33
VF16516536	84	5	VF16516717	40	28	VF16517922	60	36	VF16602598	23	33
VF16516558	37	13	VF16516717	41	32	VF16517923	60	37	VF16602599	19	36
VF16516640	1	2	VF16516717	42	23	VF16518038	25	3	VF16602599	20	36
VF16516646	8	1	VF16516750	83	5	VF16518084	27	22	VF16602600	19	37
VF16516651	90	6	VF16516754	80	28	VF16518135	40	29	VF16602600	20	37
VF16516652	90	5	VF16516754	81	28	VF16518135	41	33	VF16602606	21	27A
VF16516653	81	13	VF16516754	82	28	VF16518135	42	24	VF16602606	22	27A
VF16516653	82	13	VF16516766	80	13	VF16518150	10	11	VF16602614	21	95
VF16516654	81	13.1	VF16516767	80	13.1	VF16518193	16	14	VF16602614	22	95
VF16516654	82	13.1	VF16516768	80	13.2	VF16518205	49	1	VF16602614	23	95
VF16516655	81	13.2	VF16516769	80	13.3	VF16518210	49	17	VF16602619	21	27
VF16516655	82	13.2	VF16516772	83	7	VF16518245	4	1	VF16602619	22	27
VF16516656	81	13.3	VF16516772	84	7	VF16518524	59	17.2	VF16604641	31	1.2
VF16516656	82	13.3	VF16516772	85	7	VF16518869	10	4	VF16604726	31	1.3
VF16516657	81	13.4	VF16517079	90	4	VF16518871	10	10	VF16604727	31	1.4
VF16516657	82	13.4	VF16517144	58	3	VF16518890	31	6	VF16604728	31	1.5
VF16516658	81	13.5	VF16517146	36	1	VF16518913	88	8	VF16604729	31	1.6
VF16516663	81	4	VF16517151	54	2	VF16518921	1	14	VF16604730	31	1.7
VF16516663	82	4	VF16517160	58	2	VF16518926	27	25	VF16606401	91	27.1
VF16516664	80	18	VF16517165	58	4	VF16518934	27	16	VF16606570	60	4
VF16516664	81	18	VF16517171	51	2	VF16518970	60	42	VF16610586	89	4
VF16516664	82	18	VF16517193	37	22	VF16519102	27	14	VF16610781	34	20
VF16516677	40	1	VF16517193	38	24	VF16519106	27	18	VF16610801	1	1.1
VF16516679	80	15	VF16517194	33	61	VF16519107	27	17	VF16610801	2	1
VF16516696	40	5	VF16517194	37	23	VF16519184	33	2	VF16610873	30	58
VF16516699	40	6	VF16517197	36	10	VF16601350	94	1	VF16610895	1	13
VF16516700	40	7	VF16517197	37	24	VF16601375	94	8	VF16610913	37	16
VF16516701	40	8	VF16517215	49	16	VF16602179	6	8	VF16610922	24	5
VF16516702	40	9	VF16517215	62	3	VF16602597	21	29	VF16610922	25	5

FeedMaster 3600T / Part No Index



Part No.	Page	Pos No	Part No.	Page	Pos No	Part No.	Page	Pos No	Part No.	Page	Pos No
VF16610926	40	18	VF16611331	46	43	VF16611490	47	10	VF16613236	59	7
VF16610994	24	8	VF16611335	46	26	VF16611492	11	1	VF16613237	59	8
VF16610994	25	8	VF16611338	46	29	VF16611497	13	1	VF16613238	59	9
VF16611054	46	25	VF16611341	46	28	VF16612402	7	15	VF16613240	30	52
VF16611055	46	11	VF16611351	46	19	VF16612405	19	98	VF16613243	60	44
VF16611079	60	43.3	VF16611352	46	20	VF16612405	20	98	VF16613246	34	7
VF16611081	60	45	VF16611356	52	17	VF16612405	21	98	VF16613246	37	25
VF16611240	39	35	VF16611359	39	32	VF16612405	22	98	VF16613248	13	6
VF16611241	39	39	VF16611366	51	6	VF16612405	23	98	VF16613255	24	1
VF16611242	39	36	VF16611382	32	30	VF16612406	21	31	VF16613255	25	1
VF16611247	76	1	VF16611391	44	71	VF16612406	22	31	VF16613256	25	1.1
VF16611248	39	45	VF16611391	45	71	VF16612406	23	31	VF16613261	3	1
VF16611252	4	11	VF16611392	44	72	VF16612407	7	5	VF16613267	17	1
VF16611252	5	11	VF16611392	45	72	VF16612407	9	14	VF16613273	53	2.1
VF16611261	2	5	VF16611394	44	73	VF16612408	7	9	VF16613283	60	49
VF16611262	2	4	VF16611394	45	73	VF16612408	9	4	VF16613283	62	21
VF16611266	3	3	VF16611395	44	74	VF16612412	21	73	VF16613296	75	1
VF16611267	3	4	VF16611395	45	74	VF16612412	22	74	VF16613306	33	68
VF16611268	3	19	VF16611397	88	75	VF16612413	8	2	VF16613311	32	9
VF16611275	60	31.1	VF16611398	88	76	VF16612423	8	12	VF16613313	32	1
VF16611297	3	2	VF16611400	75	31	VF16612424	8	9	VF16613313	37	21
VF16611298	3	22	VF16611401	75	32	VF16612425	8	10	VF16613315	32	3
VF16611299	3	7	VF16611418	46	24	VF16612426	8	11	VF16613317	32	6
VF16611308	24	17	VF16611420	35	29	VF16612427	8	7	VF16613319	32	5
VF16611308	25	17	VF16611423	35	35	VF16612428	8	13	VF16613321	32	8
VF16611312	32	14	VF16611431	88	80	VF16612429	8	14	VF16613325	33	73
VF16611317	62	20	VF16611433	53	22	VF16612429	21	17	VF16613337	24	2
VF16611318	62	19	VF16611457	88	20	VF16612429	22	17	VF16613337	25	2
VF16611321	32	27	VF16611458	88	29	VF16612430	8	17	VF16613354	76	4
VF16611322	46	8	VF16611479	65	2	VF16612430	21	24	VF16613354	77	4
VF16611325	46	31	VF16611479	70	2	VF16612430	22	24	VF16613354	78	4
VF16611326	46	32	VF16611480	60	7	VF16612431	8	18	VF16613356	76	16
VF16611330	46	34	VF16611487	65	1	VF16612438	21	22	VF16613356	77	16

FeedMaster 3600T / Part No Index



Part No.	Page	Pos No	Part No.	Page	Pos No	Part No.	Page	Pos No	Part No.	Page	Pos No
VF16613356	78	16	VF16613439	30	42	VF16614457	56	410	VF16614908	44	87
VF16613359	88	22	VF16613441	30	43	VF16614458	55	2	VF16614908	45	87
VF16613360	54	3	VF16613443	30	45	VF16614458	56	415	VF16614920	47	43
VF16613364	31	24	VF16613445	30	46	VF16614459	55	3	VF16614921	47	42
VF16613374	74	12	VF16613446	30	49	VF16614459	56	421	VF16614984	29	14
VF16613377	43	24	VF16613447	30	50	VF16614460	55	5	VF16614995	29	21
VF16613380	30	54	VF16613449	31	10	VF16614460	56	423	VF16615010	29	12
VF16613387	59	6	VF16613449	37	10	VF16614461	55	9	VF16615011	27	36
VF16613389	94	10	VF16613456	76	6	VF16614461	56	431	VF16615012	29	15
VF16613390	94	6	VF16613456	77	6	VF16614462	55	4	VF16615013	29	19
VF16613391	94	3	VF16613456	78	6	VF16614463	55	18	VF16615014	29	20
VF16613392	94	2	VF16613458	76	17	VF16614464	55	19	VF16615171	31	11
VF16613394	59	1	VF16613458	77	17	VF16614464	56	413	VF16615203	64	16
VF16613396	60	1	VF16613458	78	17	VF16614465	55	20	VF16615203	68	11
VF16613400	64	15	VF16613460	76	5	VF16614465	56	430	VF16615203	69	11
VF16613405	47	1	VF16613460	77	5	VF16614466	57	21	VF16615205	68	12
VF16613406	47	2	VF16613460	78	5	VF16614467	57	22	VF16616040	7	14
VF16613408	47	3	VF16613464	47	47	VF16614468	57	25	VF16616040	9	3
VF16613409	47	4	VF16613469	48	47	VF16614469	55	26	VF16616084	6	6
VF16613410	47	5	VF16613470	48	48	VF16614470	55	33	VF16617329	7	2
VF16613411	47	6	VF16613493	48	34	VF16614471	55	32	VF16617329	9	5
VF16613412	47	7	VF16613495	35	34	VF16614472	17	19	VF16617329.86	19	84
VF16613413	47	8	VF16613497	35	45	VF16614473	17	2	VF16617329.86	20	84
VF16613417	47	52	VF16613499	47	9	VF16614474	17	3	VF16617329.86	23	84
VF16613418	47	51	VF16613719	94	9	VF16614475	17	4	VF16617330	7	3
VF16613421	47	54	VF16613728	94	7	VF16614478	17	16	VF16617330.86	19	86
VF16613422	47	53	VF16614169	1	26	VF16614479	17	15	VF16617330.86	20	86
VF16613427	47	55	VF16614444	9	2	VF16614480	17	6	VF16617331	7	6
VF16613432	47	58	VF16614447	7	13	VF16614668	63	33	VF16617332	7	8
VF16613433	30	41	VF16614447	9	9	VF16614668	71	20	VF16617333	6	4
VF16613434	30	47	VF16614454	80	17	VF16614901	35	33	VF16617334	6	3
VF16613435	30	3	VF16614456	57	31	VF16614907	44	88	VF16617335	6	5
VF16613436	30	48	VF16614457	55	1	VF16614907	45	88	VF16618602	21	93

FeedMaster 3600T / Part No Index



Part No.	Page	Pos No	Part No.	Page	Pos No	Part No.	Page	Pos No	Part No.	Page	Pos No
VF16618602	22	93	VF16630112	63	9.1	VF16630184	41	10	VF16630549	84	12
VF16618602	23	93	VF16630114	63	5.1	VF16630186	41	11	VF16630646	26	19
VF16618603	21	94	VF16630115	63	7.1	VF16630188	41	12	VF16630647	26	20
VF16618603	22	94	VF16630119	63	8.1	VF16630190	41	13	VF16630655	1	4
VF16618603	23	94	VF16630125	63	1.1	VF16630192	41	14	VF16630657	32	23.1
VF16618627	19	54	VF16630125	64	1.1	VF16630194	41	15	VF16630658	32	23
VF16618627	20	54	VF16630126	88	80	VF16630196	41	16	VF16630682	68	3
VF16618679	21	54	VF16630134	46	8.1	VF16630200	41	18	VF16630682	69	3
VF16618679	22	54	VF16630139	64	33	VF16630216	50	10	VF16630684	68	5
VF16618715	69	12	VF16630142	81	17	VF16630217	50	12	VF16630685	68	2
VF16622598	66	30	VF16630143	81	17.1	VF16630219	48	49	VF16630685	69	2
VF16624942	56	465	VF16630145	84	19	VF16630219	50	13	VF16630686	68	18
VF16625105	4	55	VF16630145	85	20	VF16630231	29	13	VF16630686	69	18
VF16625105	5	55	VF16630146	84	14	VF16630232	10	6	VF16630690	71	3
VF16625114	4	5	VF16630147	77	1	VF16630234	46	8.2	VF16630695	71	2
VF16625120	4	4	VF16630147	78	1	VF16630236	46	1	VF16630700	71	7
VF16630069	12	21	VF16630148	77	20	VF16630237	46	42.1	VF16630705	71	1
VF16630070	12	19	VF16630148	78	20	VF16630254	27	15	VF16630706	71	10
VF16630072	12	18	VF16630151	86	23.1	VF16630283	52	4	VF16630707	71	11
VF16630075	9	1	VF16630156	64	17	VF16630383	5	1	VF16630709	68	17
VF16630075	23	1	VF16630156	68	26	VF16630385	87	6	VF16630709	69	17
VF16630078	8	30	VF16630156	69	26	VF16630393	55	26	VF16630710	71	8
VF16630078	11	42	VF16630157	1	19	VF16630394	8	18	VF16630716	71	4
VF16630078	22	1	VF16630158	36	1.2	VF16630397	8	1	VF16630721	71	23
VF16630080	6	1	VF16630159	36	1.3	VF16630397	11	9.1	VF16630730	70	1
VF16630080	7	1	VF16630171	41	1	VF16630397	21	1	VF16630734	71	27
VF16630080	11	43.1	VF16630171	42	13	VF16630398	54	3.1	VF16630736	71	9
VF16630080	20	1	VF16630172	41	4	VF16630398	56	1	VF16630736.01	71	9.1
VF16630100	10	2	VF16630174	41	5	VF16630487	49	23	VF16630737	70	1
VF16630104	10	1	VF16630176	41	6	VF16630506	26	6	VF16630738	71	5
VF16630104	11	4.1	VF16630178	41	7	VF16630507	26	7	VF16630740	68	1
VF16630106	66	44	VF16630180	41	8	VF16630548	17	20	VF16630742	71	25
VF16630109	66	2	VF16630182	41	9	VF16630548	84	16	VF16630743	68	23

FeedMaster 3600T / Part No Index



Part No.	Page	Pos No	Part No.	Page	Pos No	Part No.	Page	Pos No
VF16630743	69	23	VF16631181	64	47	VF16631815	1	25.1
VF16630744	68	30	VF16631181	71	36	VF16631868	68	34
VF16630744	69	30	VF16631182	1	24	VF16631868	69	34
VF16630745	71	37	VF16631184	79	20.1	VF16631886	11	43.2
VF16630746	71	12	VF16631186	71	21.1	VF16631886	19	1
VF16630757	46	13	VF16631187	68	18.1	VF16631919	85	5
VF16630766	68	24	VF16631187	69	18.1	VF16631920	82	17
VF16630766	69	24	VF16631220	79	2.1	VF16635132	63	6.1
VF16630767.01	68	33	VF16631248	62	21.1	VF16635132	71	32.1
VF16630767.01	69	33	VF16631249	61	10	VF16635241	16	1
VF16630768.01	68	33	VF16631263	1	2.1	VF16635245	61	24
VF16630768.01	69	33	VF16631271	25	19	VF16635247	61	25
VF16630888	30	52.1	VF16631272	25	6	VF16635249	61	29
VF16630889	30	52.2	VF16631273	25	29	VF16635269	16	25
VF16630900	30	52.3	VF16631279	91	9.1	VG35.06.70	4	23
VF16630964	78	22	VF16631291	37	27	VG35.06.70	5	23
VF16630966	64	27	VF16631340	44	1.1	VG63.12.01	4	25
VF16630966	68	28	VF16631340	45	1	VG63.12.01	5	25
VF16630966	69	28	VF16631346	44	11.1	VG85.01.02	4	51
VF16631049	35	40	VF16631346	45	9	VNB3469202	16	8
VF16631049	38	6	VF16631347	44	13.1	WA116565	5	4
VF16631123	32	12	VF16631347	45	10	WA116566	5	5
VF16631123	33	64	VF16631420	82	15	WA129948	5	51
VF16631123	34	12	VF16631427	67	2	WA135075	4	21
VF16631123	37	11	VF16631429	67	5	WA135075	5	21
VF16631123	38	21	VF16631430	67	1	WA135895	4	28
VF16631126	67	15	VF16631460	53	2	WA135895	5	28
VF16631126	73	15	VF16631478	53	3.1	WA135897	4	29
VF16631129	73	5	VF16631482	16	4	WA135897	5	29
VF16631133	67	16	VF16631486	17	16.1	WA153207	4	22
VF16631133	73	16	VF16631491	52	2	WA153207	5	22
VF16631134	73	2	VF16631491	54	2.1			
VF16631135	73	1	VF16631687	85	19			



FeedMaster 3600T

1366 < Mach. ID <=

Maschinenfabrik Stolpen GmbH
Pirnaer Landstraße 24
D-01833 Stolpen
Germany
+49 35973 2240
+49 35973 22414

© Kverneland Group

All rights reserved. No parts of this book may be reproduced, stored in a database or retrieval system, or published in any form or in any way, electronically, mechanically, optically, by print, photo print, microfilm (including micro and macro fiche), or any other means, including all video and CD systems, without prior written permission from the publisher.

Print date: 2019-04-24

