

Feedex 360 T

Spare Parts Manual

Article number: A143350740
Language: EN
Production year (from): 2011
Prod. Series nr (from): 6631
1366 < Mach. ID <=



Feedex 360 T / Table of Contents

PosNo.	Assembly group	Page
B	DRIVE	1
B	ANGULAR GEAR	2
B	SPUR GEAR BOOR	3
B	UNIVERSAL-JOINT SHAFT	4
B	UNIVERSAL-JOINT SHAFT	5
C	TANDEM-BRAKE AXLE (-A 2011)	6
C	BRAKE (-A 2011)	7
C	BRAKE AXLE TANDEM AUTOREVERSE TANDEM.PRESS AIR ()	8
C	TANDEM-WHEEL AXLE HYDRAULIC +501	9
C	ASSEMBLY PENDULAR	10
C	SPRING BORN TANDEM AXLE (8TO.)	11
C	ASSORTMENT OF WHEEL	12
C	BRAKE CABLE TAN. AXLE AUTOREVERSE	13
C	HANDBRAKE TAND AXLE SPR BORN PRESS AIR BRAKE	14
C	HANDBRAKE TAND.AXLE 9TO.2 BRAKES HYDR.	15
C	BRAKE HYDRAULIC (FANCE)	16
C	PARKING STAND (-A 2016)	17
C	PARKING STAND (+A 2017)	18
C	BRAKE AXLE TANDEM HYDRAULIC TRACK 2000 (constructive variant)	19
C	BRAKE AXLE TANDEM HYDRAULIC ()	20
C	BRAKE AXLE TANDEM AUTOREVERSE ()	21
C	BRAKE AXLE TANDEM PRESS AIR ()	22
C	TANDEM-WHEEL AXLE HYDRAULIC ()	23
D	HYDR. BRAKE SYSTEM FOR TANDEM AXLE 2-WHEELS BRAKED	24
D	HYDR. BRAKE SYSTEM FOR TANDEM AXLE 4-WHEELS BRAKED	25
D	COMPRES.AIR SYSTEM SPRUNG TANDEM AXLE_SINGLE AXIS (-A 2017)	26
D	COMPRES.AIR SYSTEM SPRUNG TANDEM AXLE_SINGLE AXIS (+A 2018)	27
D	PRESS.AIR BRAKE WITH AUTOM.LOAD-SENSING VALVE (+A	28

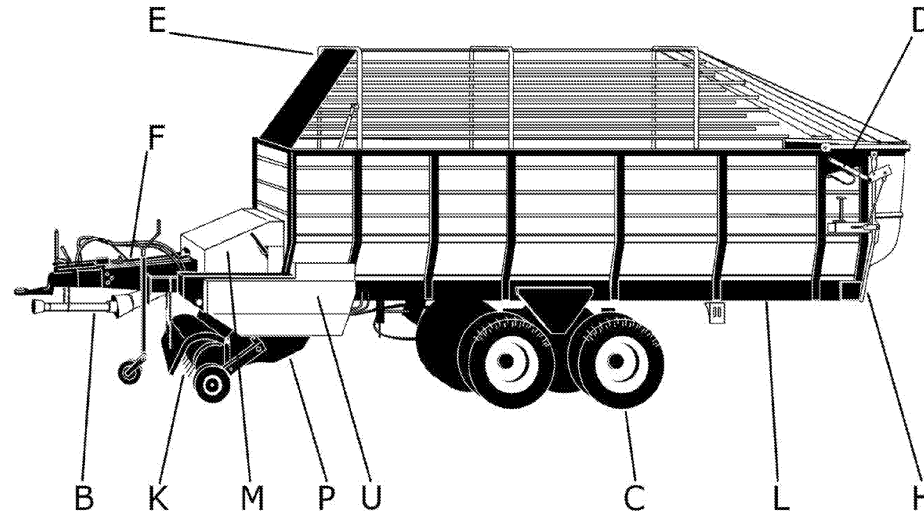

Legende - legend - légende - leyenda

Abkürzungen abbreviation abréviation abreviación	Benennung description designation denominación	Englisch	Französisch	Spanisch
K	Grundausrüstung, ohne Dosierwalzen	basic equipment, without metering roller	équipement de base, sans cylindre de dosage	equipo básico, sin rodillo dosificación
D	Dosierwalzen Variante	metering roller variant	variante cylindre de dosage	variantes rodillo dosificación
+	ab (Maschine-Nr.)	from machine number	à partir de machine numéro	a partir de máquina número
-	bis (Maschine-Nr.)	up to machine number	jusqu à numéro de la machine	hasta máquina número
+A	ab Baujahr	from year of construction	à partir de l'année de construction	desde el año de construcción
-A	bis Baujahr	to year of construction	jusqu à l'année de construction	hasta el año de construcción
E	ersetzt	replaced	remplacé	sustituye
V	Ausrüstvariante	option	variante	variante
X	gehört zu Pos.Nr.	belongs to pos.no.	fait partie de pos.no.	forma parte de pos.no.
S	siehe Seite	see page	voir page no.	véase en página
b	besteht aus	consist of	se composer de	consistente en

Vicon

end-code	Farbbezeichnung color name-nom couleur-nombre del color
A143.....00	no color specification
A143.....86	RAL 7021 Dark Grey
A143.....94	RAL 3000 Red
VF.....86	RAL 7021 Dark Grey
VF.....94	RAL 3000 Red



Feedex 360 T / Table of Contents

PosNo.	Assembly group	Page
	2018)	
D	PRESS.AIR BRAKE WITH AUTOM.LOAD-SENSING VALVE (-A 2017)	29
D	PRESS.AIR BRAKE WITH AUTOM.LOAD-SENSING VALVE (+A 2018)	30
D	COMPRESSED AIR SYSTEM TANDEM AXLE SPRING BORN (-A 2017)	31
D	COMPRESSED AIR SYSTEM TANDEM AXLE SPRING BORN (+A 2018)	32
D	HYDR.SCRAPER FLOOR+TAILGATE	33
D	HYDR. INSTALLATION BASIC CONTENT	34
D	HYDR. FOR REAR GATE	35
D	HYDR. FOR PICK-UP	36
D	HYDR. FOR DRY FORAGE SUPERST.	37
D	HYDR. FOR DRY FORAGE SUPERST.	38
D	HYDR. FOR CRANKED DRAWBAR	39
D	HYDR. STEERING	40
D	HYDRAULIC FOR CONVEYOR	41
D	LUBE SYSTEM	42
D	LUBE SYSTEM DRUM WITH 4 RAKES	43
D	LUBE SYSTEM DRUM WITH 6 RAKES	44
D	LUBE SYSTEM DRUM WITH 5 RAKES	45
E	GREEN FODDER SUPERSTRUCTURE SUPPORTS	46
E	GREEN FODDER SUPERSTRUCTURE - SIDE PANELS (-A 2013)	47
E	GREEN FODDER SUPERSTRUCTURE - SIDE PANELS (+A 2014)	48
E	HYDR. ADJUSTEMENT OF BACK NET UNIT	49
E	DRY FORAGE SUPERST. YOKE-PROFILED TUBE	50
E	DRY FORAGE SUPERST. CANVAS AND CABLES	51
D	LEVEL INDICATOR	52
E	RIGID MOUNTING, CANVAS AND CABLES	53
F	FRAME	54
F	DRAWBAR Z 1040	55

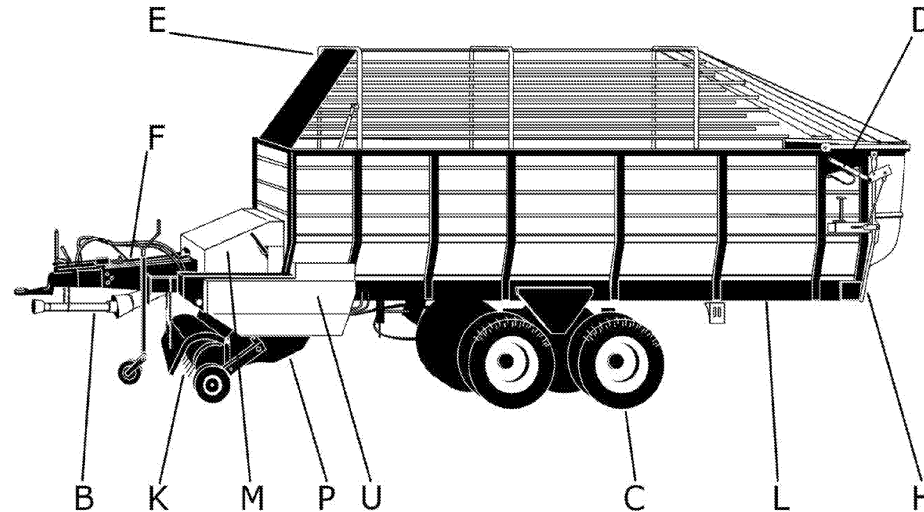

Legende - legend - légende - leyenda

Abkürzungen abbreviation abréviation abreviación	Benennung description designation denominación	Englisch	Französisch	Spanisch
K	Grundausstattung, ohne Dosierwalzen	basic equipment, without metering roller	équipement de base, sans cylindre de dosage	equipo básico, sin rodillo dosificación
D	Dosierwalzen Variante	metering roller variant	variante cylindre de dosage	variantes rodillo dosificación
+	ab (Maschine-Nr.)	from machine number	à partir de machine numéro	a partir de máquina número
-	bis (Maschine-Nr.)	up to machine number	jusqu'à numéro de la machine	hasta máquina número
+A	ab Baujahr	from year of construction	à partir de l'année de construction	desde el año de construcción
-A	bis Baujahr	to year of construction	jusqu'à l'année de construction	hasta el año de construcción
E	ersetzt	replaced	remplacé	sustituye
V	Ausrüstvariante	option	variante	variante
X	gehört zu Pos.Nr.	belongs to pos.no.	fait partie de pos.no.	forma parte de pos.no.
S	siehe Seite	see page	voir page no.	véase en página
b	besteht aus	consist of	se composer de	consistente en

Vicon

end-code	Farbbezeichnung color name-nom couleur-nombre del color
A143.....00	no color specification
A143.....86	RAL 7021 Dark Grey
A143.....94	RAL 3000 Red
VF.....86	RAL 7021 Dark Grey
VF.....94	RAL 3000 Red



Feedex 360 T / Table of Contents

PosNo.	Assembly group	Page
F	DRAWBAR Z 450	56
F	OVERR. DRAWBAR	57
F	OVERRUNNING DEVICE (-0700)	58
F	OVERRUNNING DEVICE AVEG 2000 BPW (+0701)	59
F	OVERRUN BRAKE BRAKE LEVER (-0700)	60
F	ADJUSTING SPINDLE	61
H	ELECTR.REMOTE CONTR. PILOTBOX-T	62
H	ELECTR. EQUIPM. DISTRIBUTION BOX	63
H	ELECTR. EQUIPM. LIGHTING	64
H	ELECTR. EQUIPM. BACK NET	65
K	PICK-UP 1.6 SCRAPER	66
K	PICK-UP 1.6 DRUM	67
K	PICK-UP 1.6 BAFFLE PLATE	68
K	PICK-UP 1.6 TACTILE WHEEL	69
K	PICK-UP 1.6 BAFFLE PLATE WITH ROLE	70
K	PICK-UP 1.8 DRUM	71
K	PICK-UP 1.8 DRUM (+A 2004)	72
K	PICK-UP BAFFLE-PLATE	73
K	PICK-UP SCAPPER	74
K	PICK-UP 1.8 TACTILE WHEEL	75
K	PICK-UP 1.8 BAFFLE PLATE WITH ROLE	76
L	SCRAPER FLOOR BOARDS	77
L	SCRAPER FLOOR	78
L	DRUM ELEVATOR GRATE 4 RAKE	79
L	DRUM ELEVATOR GRATE 6 RAKE	80
L	DRUM ELEVATOR GRATE 5 RAKE	81
L	DRUM ELEVATOR SIDE MEM. A. COV .SHEET	82
L	DRUM ELEVATOR DRUM 4- RAKE	83
L	DRUM ELEVATOR DRUM 6 RAKE	84
L	DRUM ELEVATOR DRUM 5 RAKE	85
L	DRUM ELEVATOR CRANK WITH BEARING 4-RAKE	86
L	DRUM ELEVATOR CRANK WITH BEARING 6-RAKE	87
L	DRUM ELEVATOR CRANK WITH BEARING 5-RAKE	88

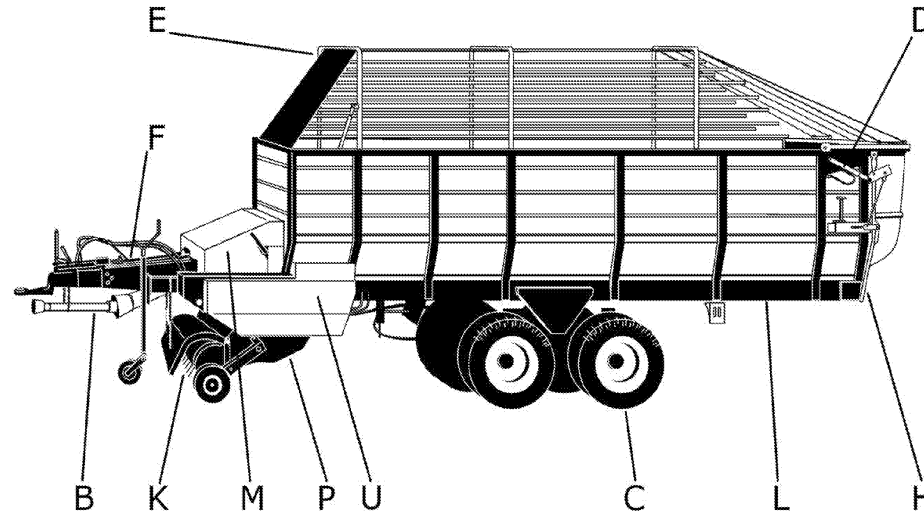

Legende - legend - légende - leyenda

Abkürzungen abbreviation abréviation abreviación	Benennung description désignation denominación	Englisch	Französisch	Spanisch
K	Grundausstattung, ohne Dosierwalzen	basic equipment, without metering roller	équipement de base, sans cylindre de dosage	equipo básico, sin rodillo dosificación
D	Dosierwalzen Variante	metering roller variant	variante cylindre de dosage	variantes rodillo dosificación
+	ab (Maschine-Nr.)	from machine number	à partir de machine numéro	a partir de máquina número
-	bis (Maschine-Nr.)	up to machine number	jusqu à numéro de la machine	hasta máquina número
+A	ab Baujahr	from year of construction	à partir de l'année de construction	desde el año de construcción
-A	bis Baujahr	to year of construction	jusqu à l'année de construction	hasta el año de construcción
E	ersetzt	replaced	remplacé	sustituye
V	Ausrüstvariante	option	variante	variante
X	gehört zu Pos.Nr.	belongs to pos.no.	fait partie de pos.no.	forma parte de pos.no.
S	siehe Seite	see page	voir page no.	véase en página
b	besteht aus	consist of	se composer de	consistente en

Vicon

end-code	Farbbezeichnung color name-nom couleur-nombre del color
A143.....00	no color specification
A143.....86	RAL 7021 Dark Grey
A143.....94	RAL 3000 Red
VF.....86	RAL 7021 Dark Grey
VF.....94	RAL 3000 Red

Feedex 360 T / Table of Contents



PosNo.	Assembly group	Page
L	DRUM ELEVATOR PINION SHAFT	89
L	DRUM ELEVATOR RELEASE LEVER	90
M	PROT.HOOD	91
M	MUDGUARD SMALL TANDEM AXLE	92
M	MUDGUARD BROAD TANDEM AXLE	93
P	CUTTING DEVICE	94
P	DOUBLE-CHOPM EQUIPERN.	95
U	INSTRUMENT BOARD FOR TÉLÉ COMMAND.	96
U	WARNING DECAL EU	97
U	DECALS	98

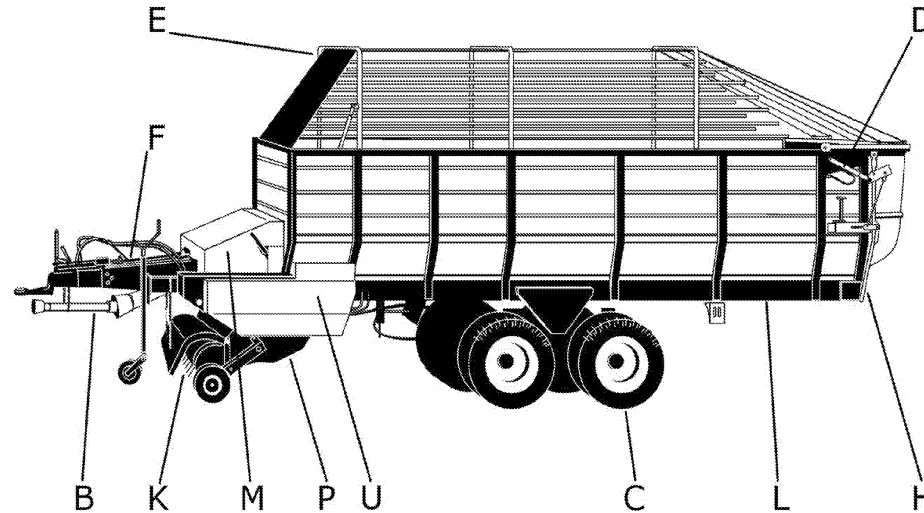

Legende - legend - légende - leyenda

Abkürzungen abbreviation abréviation abreviación	Benennung description désignation denominación	Englisch	Französisch	Spanisch
K	Grundausrüstung, ohne Dosierwalzen	basic equipment, without metering roller	équipement de base, sans cylindre de dosage	equipo básico, sin rodillo dosificación
D	Dosierwalzen Variante	metering roller variant	variante cylindre de dosage	variantes rodillo dosificación
+	ab (Maschine-Nr.)	from machine number	à partir de machine numéro	a partir de máquina número
-	bis (Maschine-Nr.)	up to machine number	jusqu'à numéro de la machine	hasta máquina número
+A	ab Baujahr	from year of construction	à partir de l'année de construction	desde el año de construcción
-A	bis Baujahr	to year of construction	jusqu'à l'année de construction	hasta el año de construcción
E	ersetzt	replaced	remplacé	sustituye
V	Ausrüstvariante	option	variante	variante
X	gehört zu Pos.Nr.	belongs to pos.no.	fait partie de pos.no.	forma parte de pos.no.
S	siehe Seite	see page	voir page no.	véase en página
b	besteht aus	consist of	se composer de	consistente en

Vicon

end-code	Farb-Nr.-color number-nombre de couleurs-numero de color	Farbbezeichnung color name-nom couleur-nombre del color
A143.....00		no color specification
A143.....86	RAL 7021	Dark Grey
A143.....94	RAL 3000	Red
VF.....86	RAL 7021	Dark Grey
VF.....94	RAL 3000	Red

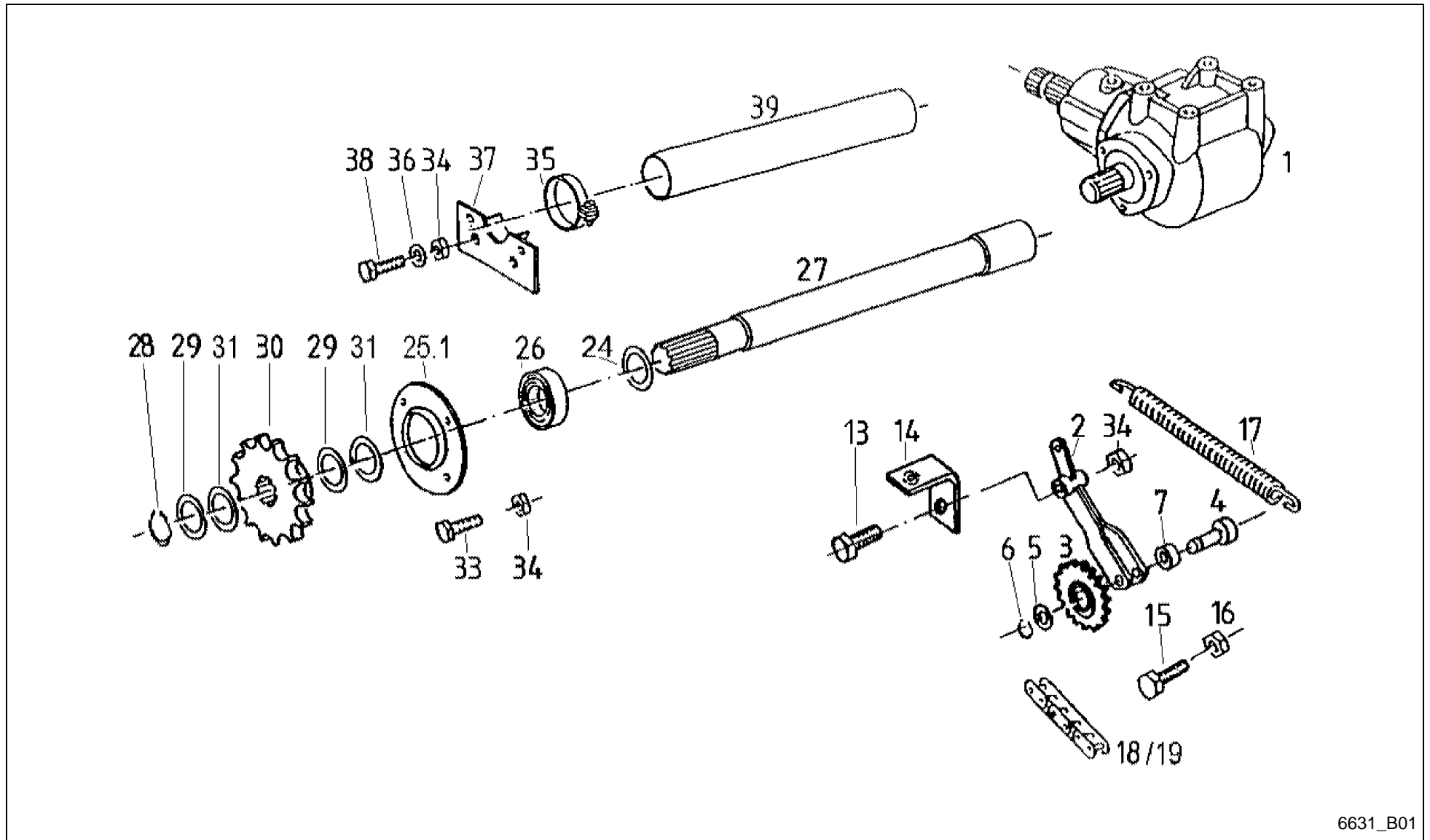



Feedex 360 T / DRIVE

PosNo.	Part No.	Qty.	Description	Remark
1	VF06575231	1	ANGLE DRIVE	=> B02a bis 1999
1.1	VF16610801	1	ANGLE DRIVE	=> B02 ab 2000
2	VF16516640	1	TENSIONER	ersetzbar durch Pos.2.1
2.1	VF16631263	1	TENSIONER	ab Y 2006
3	VF16513217	1	SPROCKET	
4	VF16630655	1	BOLT WELDED	
5	VF06214588	1	SHIM	
6	VF01107737	1	CIRCLIP	
7	VF06580174	2	SPACER	
13	VF16610895	1	HEX.BOLT	
14	VF16518921	1	ANGLE PLATE	
15	KG00480461	1	HEX. SCREW M16X50 8.8	
16	VF01112886	1	HEX. NUT	
17	VF01142492	1	DRAW SPRING	
18	VF01142993.01	1	ROLLER CHAIN	bei Kupplungsnahe 28z
19	VF16630157	1	ROLLER CAIN	bei Kupplungsnahe 25z nur noch Ersatz!
24	VF16631182	1	SPACER	
25.1	VF16631815	1	FLANGED SLEEVE CASE	
26	VF16614169	1	BALL BEARING	
27	VF16513000	1	DRIVE SHAFT	
28	VF01107755	1	CIRCLIP	
29	VF01137379	6	SHIM 40 X 50 X 2,5 D988-2	
30	VF16513003	1	SPROCKET	
31	VF06214493	3	SPACER 40X50X1 D988	
33	VF01112529	2	HEX.HEAD SCREW	
34	VF06209769	4	LOCK NUT	
35	VF01128272	1	HOSE CLIP	
36	VF06214207	2	WASHER	
37	VF06550405	1	SUPPORT PLATE	
38	VF01112538	2	HEX.HEAD SCREW	
39	VF06556888	1	PROTECTING TUBE	

Feedex 360 T / ANGULAR GEAR

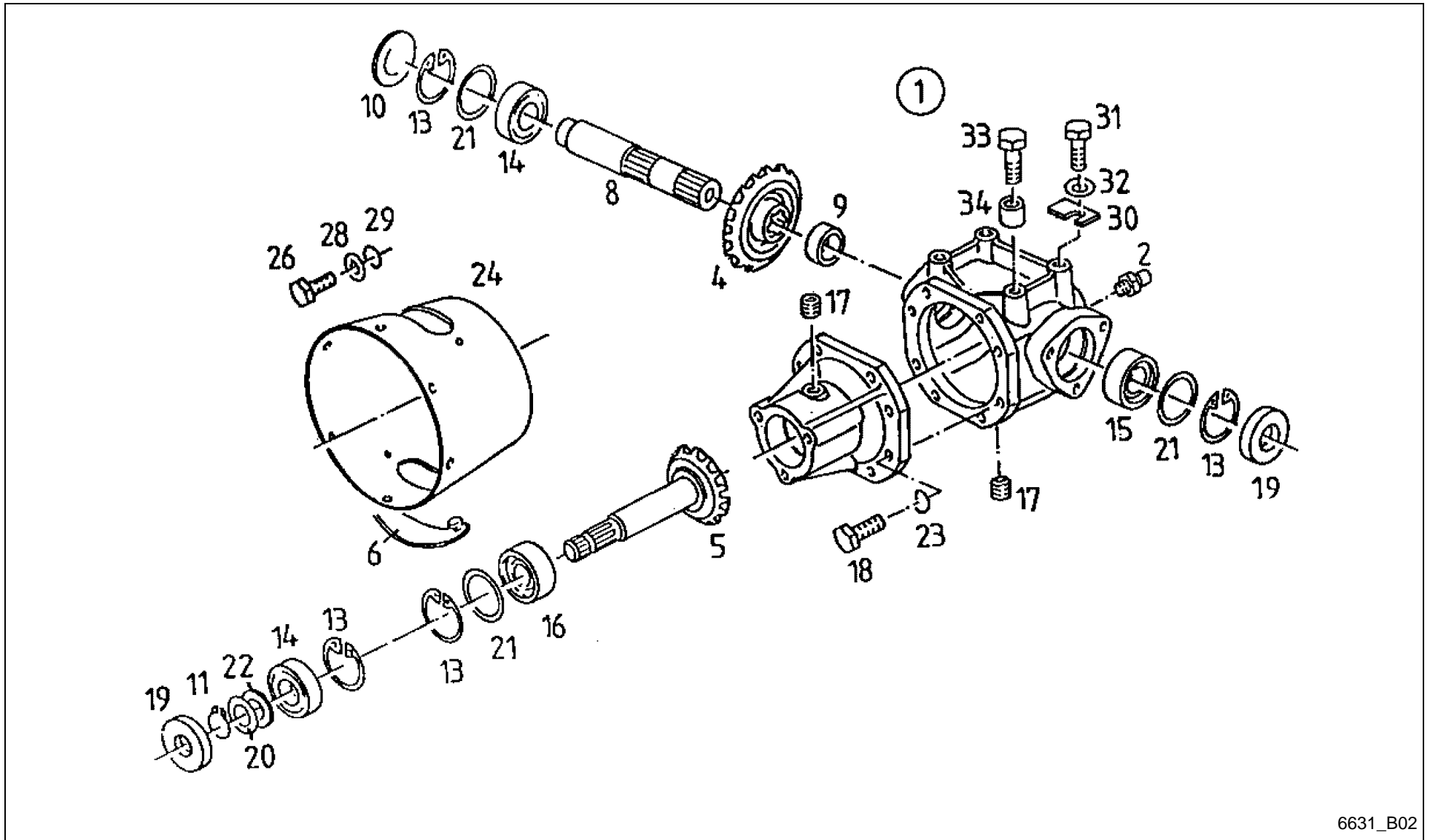

6631_B02



Feedex 360 T / ANGULAR GEAR

PosNo.	Part No.	Qty.	Description	Remark
1	VF16610801	1	ANGLE DRIVE	
2	VF06585321	1	VENTING SCREW	
4	VF16611262	1	BEVEL GEAR	
5	VF16611261	1	PINION SHAFT	
6	VF06554188	2	COVER	
8	VF06295430	1	OUTPUT SHAFT	
9	VF11439109110	1	BUSH	
10	VF06557587	1	CAP	
11	VF01137321	1	RING	
13	VF01107855	4	CIRCLIP	
14	VF01109063	2	GROOVE BALL BEARING	
15	VF01109958	1	TAPER R. BEARING	
16	VF01110002	1	TAPER R. BEARING	
17	VF01110415	3	SCREW PLUG	
18	VF01112429	8	HEX. HEAD SCREW	
19	VF01172407	2	RAD.SEAL RING	
20	VF06214490		SPACER	
20	VF06214491		SPACER	
20	VF06214492		SPACER 40X50X0,5 D988	
20	VF01137379		SHIM 40 X 50 X 2,5 D988-2	
21	VF06214521		SPACER	
21	VF06214520		SPACER	
21	VF06214519		SPACER	
23	VF01102800	8	SPRING WASHER	
24	VF06578978	1	PROTECTING CUP	
26	VF01112307	3	HEX. HEAD SCREW	
28	VF06214246	3	WASHER 9X18X2 GALV.	
29	VF01102799	3	SPRING WASHER	
30	VF06575248		SPACER / SHIM	
30	VF06575249		SPACER / SHIM	
30	VF06575250		SPACER / SHIM	
31	VF01177810	2	HEX.BOLT	
32	VF01142556	4	SPACING RING	
33	VF01177888	2	HEX.BOLT	
34	VF06575227	2	SPACER RING	

Feedex 360 T / SPUR GEAR BOOR

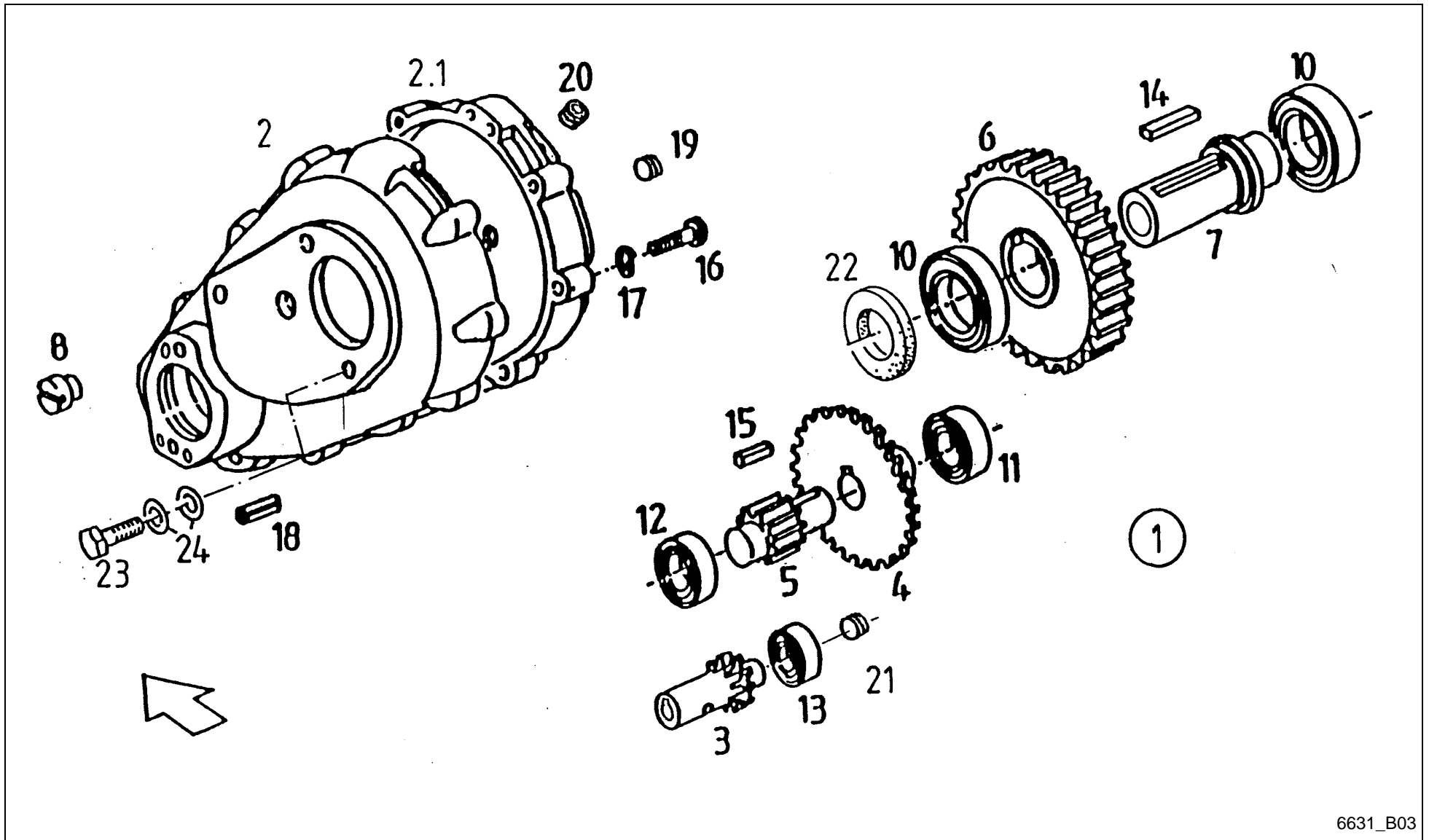

6631_B03



Feedex 360 T / SPUR GEAR BOOR

PosNo.	Part No.	Qty.	Description	Remark
1	VF16613261	1	SPUR-GEARING	
2	VF16611297	1	HALF-HOUSING	
2.1	VF16513607	1	HALF-HOUSING	
3	VF16611266	1	PINION SHAFT	
4	VF16611267	1	SPUR GEAR	
5	VF16513621	1	PINION SHAFT	
6	VF16513622	1	SPUR GEAR	
7	VF16611299	1	QUILL SHAFT	
8	VF16513624	1	PIN/SPIGOT	
10	VF01397576	2	BALL BEARING	
11	VF01108981	1	GR. BALL BEARING	
12	VF01109057	1	GR. BALL BEARING	
13	VF01109044	1	GR. BALL BEARING	
14	VF01397575	1	KEY	
15	VF06272542	1	KEY	
16	VF01126929	10	SCREW M10X 50D912 88A3C	
17	VF01102800	10	SPRING WASHER	
18	VF01397859	2	DOWEL PIN	
19	VF16611268	1	SCREW PLUG	
20	VF01110415	1	SCREW PLUG	
21	VF01124441	1	SCREW PLUG	
22	VF16611298	1	SEAL RING	
23	VF01177887	3	SCR.M16X40D933 8.8 GALV.DIN267-27MKL	
24	VF06214217	6	WASHER 17X28X3DIN1441 GALV.	

Feedex 360 T / UNIVERSAL-JOINT SHAFT

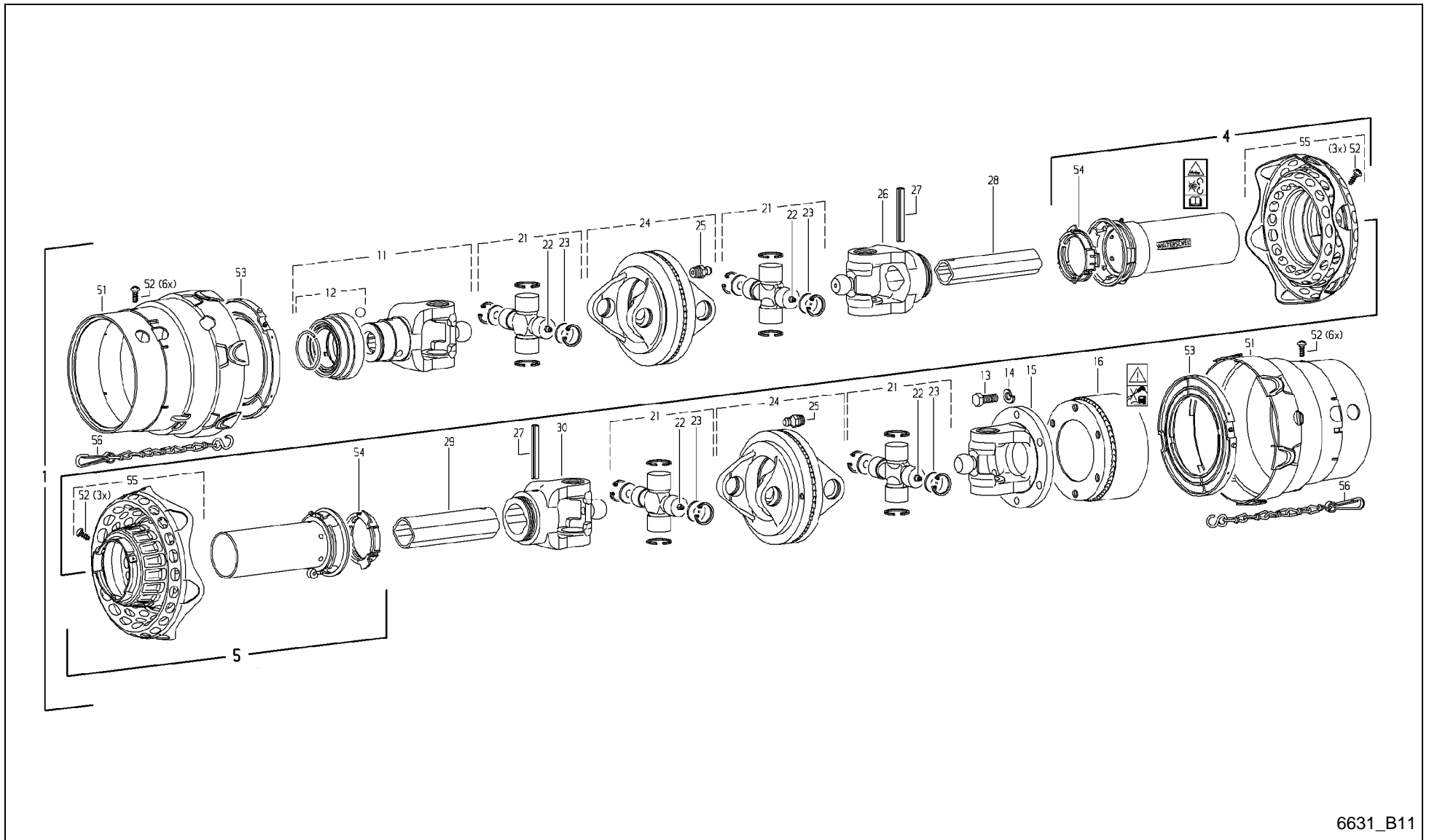

6631_B11

Feedex 360 T / UNIVERSAL-JOINT SHAFT



PosNo.	Part No.	Qty.	Description	Remark
1	VF16518245	1	UNIV PROP SHAFT	
4	VF16625120	1	PROTECTION HALF	
5	VF16625114	1	PROTECTION HALF	
11	VF16611252	1	QS-FORK KPL.	
12	VF06586171	1	FASTENER/LOCK	
13	KG00476561	6	HEX. SCREW M12X30 8.8	
14	A100000300	6	SPRING WASHER DIN127-A12	
15	VF16513601	1	FLANGED FORK	
16	A143502000	1	CLUTCH 1500NM	
21	WA135075	4	CROSS AND BEARING KIT 2480	
22	WA153207	4	GREASE NIPPLE	
23	VG35.06.70	8	DISC	
24	VF06586755	2	DOUBLE YOKE	
25	VG63.12.01	2	GREASE NIPPLE AM8X1-DIN71412	
26	VF06582340	1	FORK	
27	KG01194500	2	TENSION PIN 10X80	
28	WA135895	1	PROFILE TUBE	
29	WA135897	1	PROFILE TUBE	
30	VF16513605	1	FORK	
51	VG85.01.02	2	GUARD	
52	KG00742063	18	TAPPING SCREW 3.5X9.5 4.8	
53	VF16513616	2	SLIDING RING	
54	VF06581954	2	BEARING RING	
55	VF16625105	2	GUARD	
56	VF16513618	1	CHAIN 600MM	

Feedex 360 T / UNIVERSAL-JOINT SHAFT

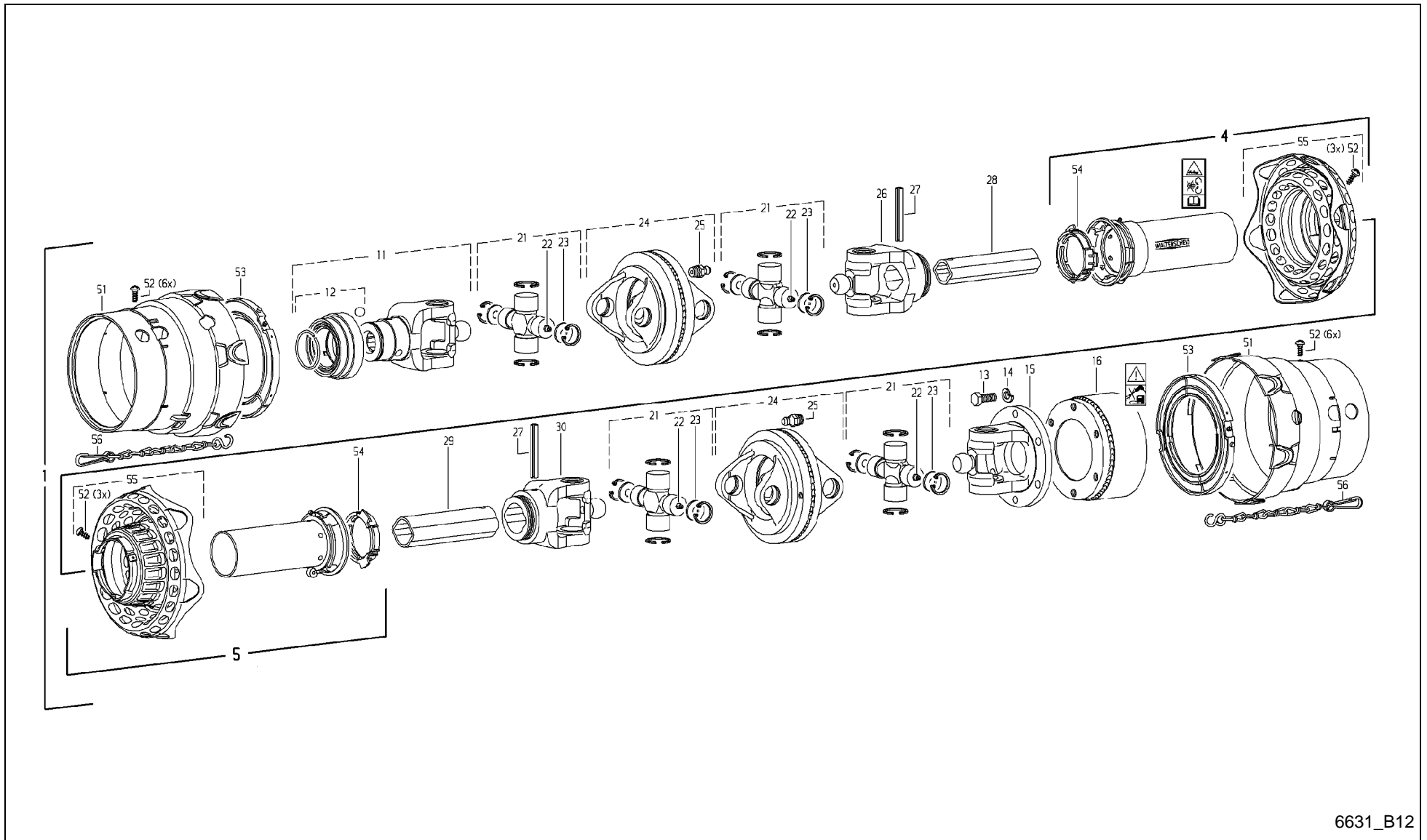

6631_B12



Feedex 360 T / UNIVERSAL-JOINT SHAFT

PosNo.	Part No.	Qty.	Description	Remark
1	VF16630383	1	SHAFT	
4	WA116565	1	OUTER GUARD HALF	
5	WA116566	1	INNER GUARD HALF BLACK	
11	VF16611252	1	QS-FORK KPL.	
12	VF06586171	1	FASTENER/LOCK	
13	KG00476561	6	HEX. SCREW M12X30 8.8	
14	A100000300	6	SPRING WASHER DIN127-A12	
15	VF16513601	1	FLANGED FORK	
16	A143501900	1	CAM CLUTCH	
21	WA135075	4	CROSS AND BEARING KIT 2480	
22	WA153207	4	GREASE NIPPLE	
23	VG35.06.70	8	DISC	
24	VF06586755	2	DOUBLE YOKE	
25	VG63.12.01	2	GREASE NIPPLE AM8X1-DIN71412	
26	VF06582340	1	FORK	
27	KG01194500	2	TENSION PIN 10X80	
28	WA135895	1	PROFILE TUBE	
29	WA135897	1	PROFILE TUBE	
30	VF16513605	1	FORK	
51	WA129948	2	GUARD CONE SDF25-2480 BLACK	
52	KG00742063	18	TAPPING SCREW 3.5X9.5 4.8	
53	VF16513616	2	SLIDING RING	
54	VF06581954	2	BEARING RING	
55	VF16625105	2	GUARD	
56	VF16513618	1	CHAIN 600MM	

Feedex 360 T / TANDEM-BRAKE AXLE (-A 2011)

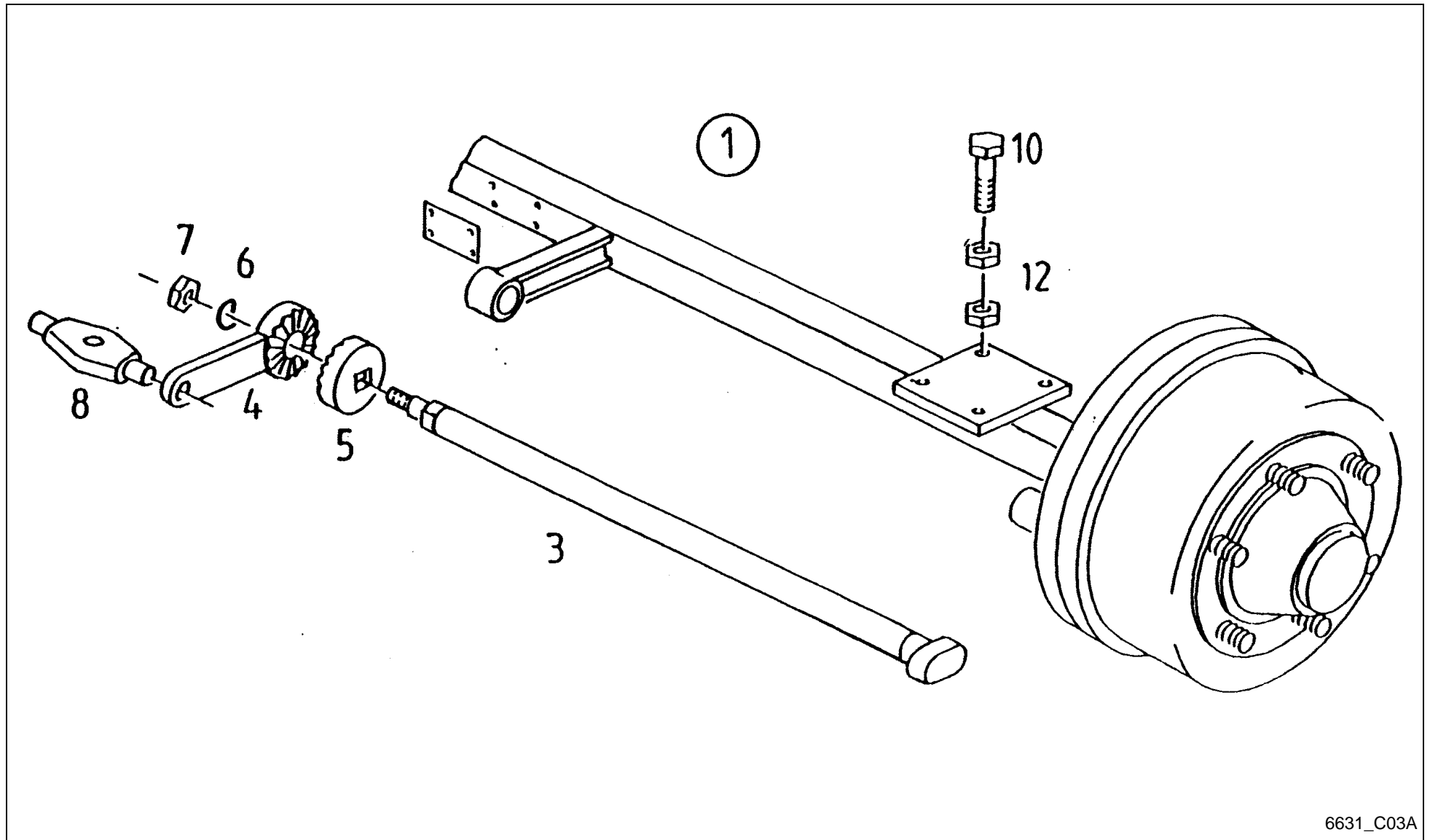

6631_C03A

Feedex 360 T / TANDEM-BRAKE AXLE (-A 2011)



PosNo.	Part No.	Qty.	Description	Remark
1	VF16630080	1	BRAKING SPINDLE	=> C04A/C09
3	VF16617334	2	BRAKE SHAFT	
4	VF16617333	2	BRAKE LEVER	
5	VF16617335	2	TOOTHED RING	
6	VF16616084	2	SPRING WASHER	
7	VF01133798	2	HEX. NUT	
8	VF16602179	1	COMPENSATOR	
10	VF06273759	8	HEX. HEAD SCREW	
12	VF01112886	16	HEX. NUT	

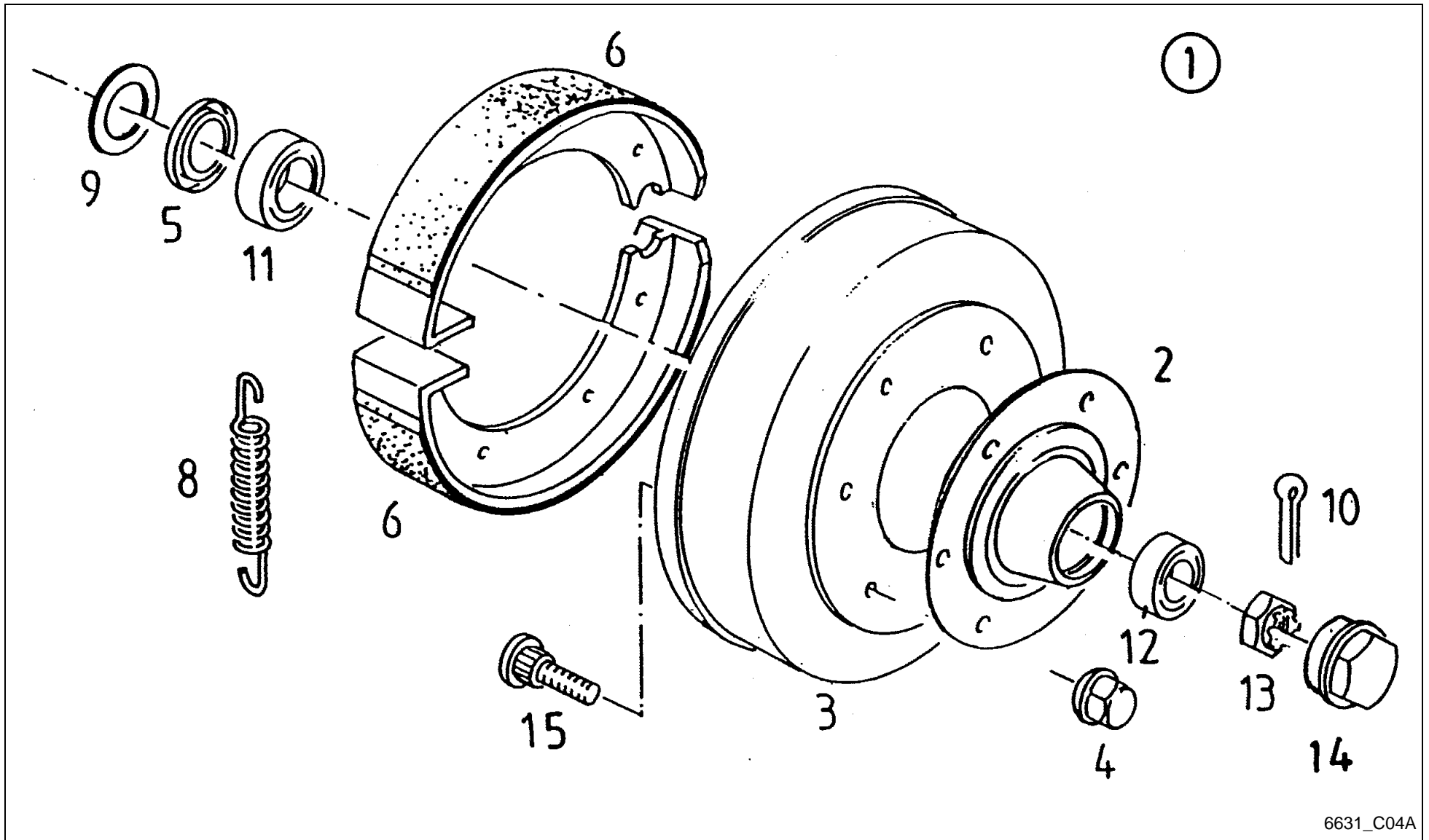

6631_C04A

Feedex 360 T / BRAKE (-A 2011)



PosNo.	Part No.	Qty.	Description	Remark
1	VF16630080	1	BRAKING SPINDLE	=> C03A/C09
2	VF16617329	2	WHEEL HUB	
3	VF16617330	2	BRAKE DRUM	
4	VF16515017	12	WHEEL NUT	
5	VF16612407	2	SEALING RING	
6	VF16617331	4	BRAKE SHOE	
8	VF16617332	4	TENSION SPRING	
9	VF16612408	2	RING	
10	VF01140002	2	SPLIT PIN	
11	VF01101596	2	TAP ROLLER BEARING AXLE	
12	VF01110001	2	TAPER R. BEARING	
13	VF16614447	2	CASTELLATED NUT	
14	VF16616040	2	WHEEL CAP	
15	VF16612402	12	WHEEL STUD	

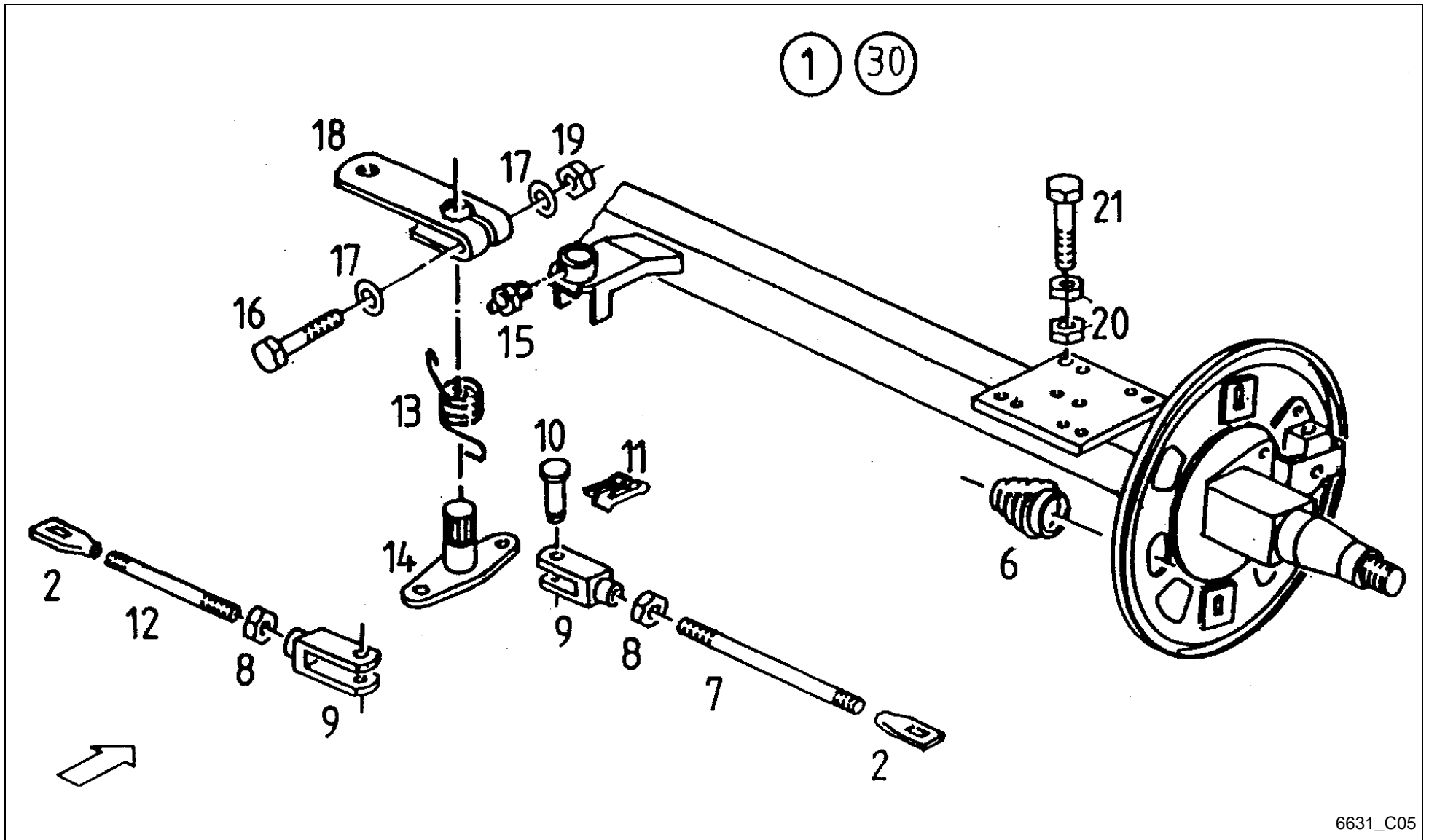

6631_C05

Feedex 360 T / BRAKE AXLE TANDEM AUTOREVERSE TANDEM.PRESS AIR ()



PosNo.	Part No.	Qty.	Description	Remark
1	VF16516646	1	BRAKE AXLE	=> C09 -700 Rückm.
1	VF16630397	1	BRAKE AXLE	+701 Rückmatic
2	VF16612413	2	HINGED PIECE	
6	VF16503949	2	BELLOWS	
7	VF16612427	1	BRAKE BAR	
8	VF01112858	2	NUT	
9	VF16612424	2	CLEVIS	
10	VF16612425	2	PIN/BOLT/STUD	
11	VF16612426	2	LOCK/COTTER	
12	VF16612423	1	BRAKE BAR	
13	VF16612428	1	TORSION SPRING	
14	VF16612429	1	LEVER/ARM	
15	VF01120692	1	GREASE NIPPLE H1 AM 6X1 DIN 71412	
16	VF01111325	1	HEX.HEAD SCREW	
17	VF16612430	2	WASHER/DISC/PLATE	
18	VF16612431	1	YOKE/RETAINER	X1,X30 -700 Rückm.
18	VF16630394	1	YOKE/RETAINER	X1.1 +701 Rückm.
19	VF01102659	1	HEX. NUT	
20	VF01112886	16	HEX. NUT	
21	VF06273759	8	HEX. HEAD SCREW	
30	VF16630078	1	BRAKE AXLE	+701 Druckluft

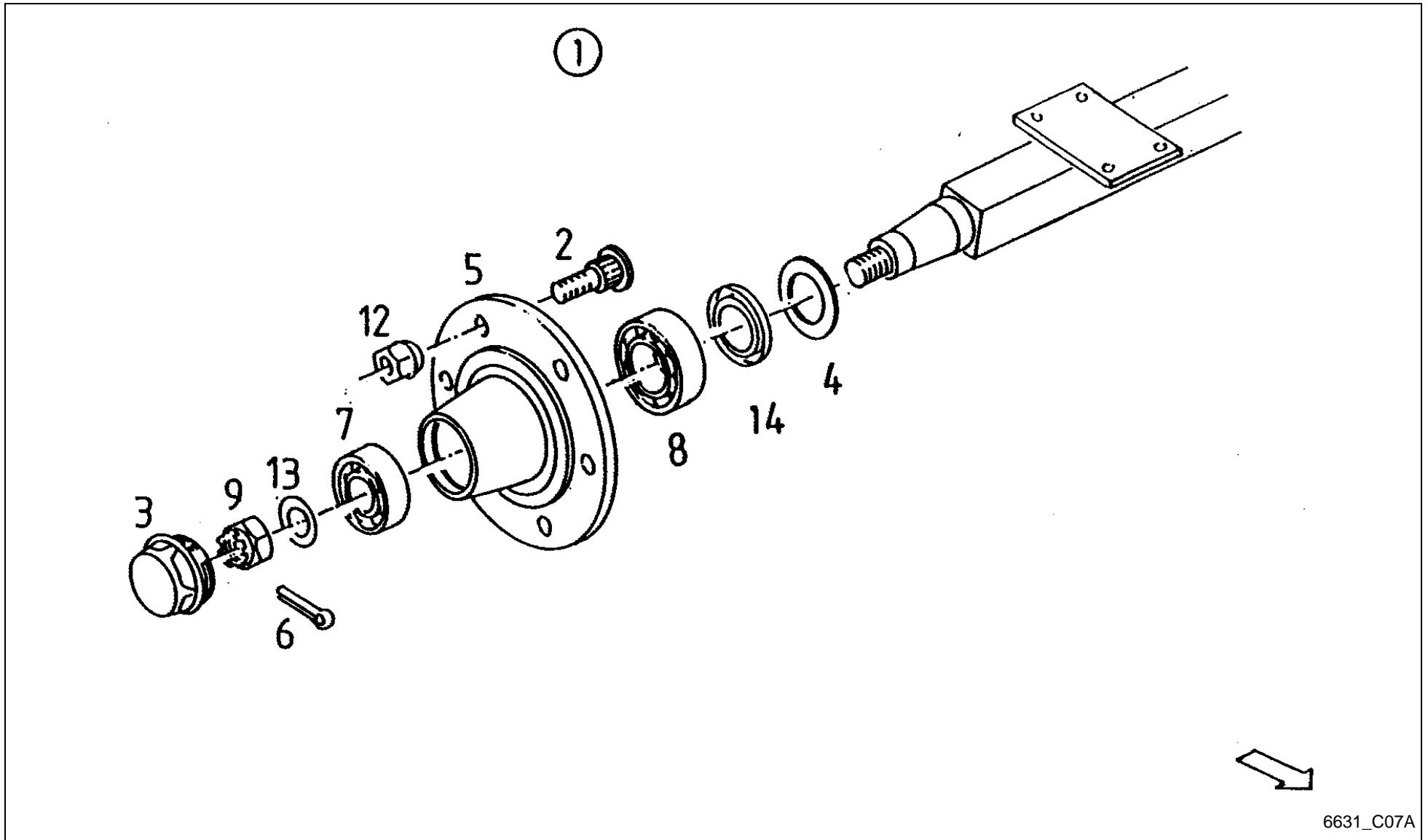

6631_C07A

Feedex 360 T / TANDEM-WHEEL AXLE HYDRAULIC +501



PosNo.	Part No.	Qty.	Description	Remark
1	VF16630075	1	WHEEL AXLE	=> C09
2	VF16614444	12	BOLT, WHEEL	
3	VF16616040	2	WHEEL CAP	
4	VF16612408	2	RING	
5	VF16617329	2	WHEEL HUB	
6	VF01140002	2	SPLIT PIN	
7	VF01110001	2	TAPER R. BEARING	
8	VF01101596	2	TAP ROLLER BEARING AXLE	
9	VF16614447	2	CASTELLATED NUT	
12	VF16515017	12	WHEEL NUT	
13	VF06557524	2	WASHER/DISC/PLATE	
14	VF16612407	2	SEALING RING	

Feedex 360 T / ASSEMBLY PENDULAR

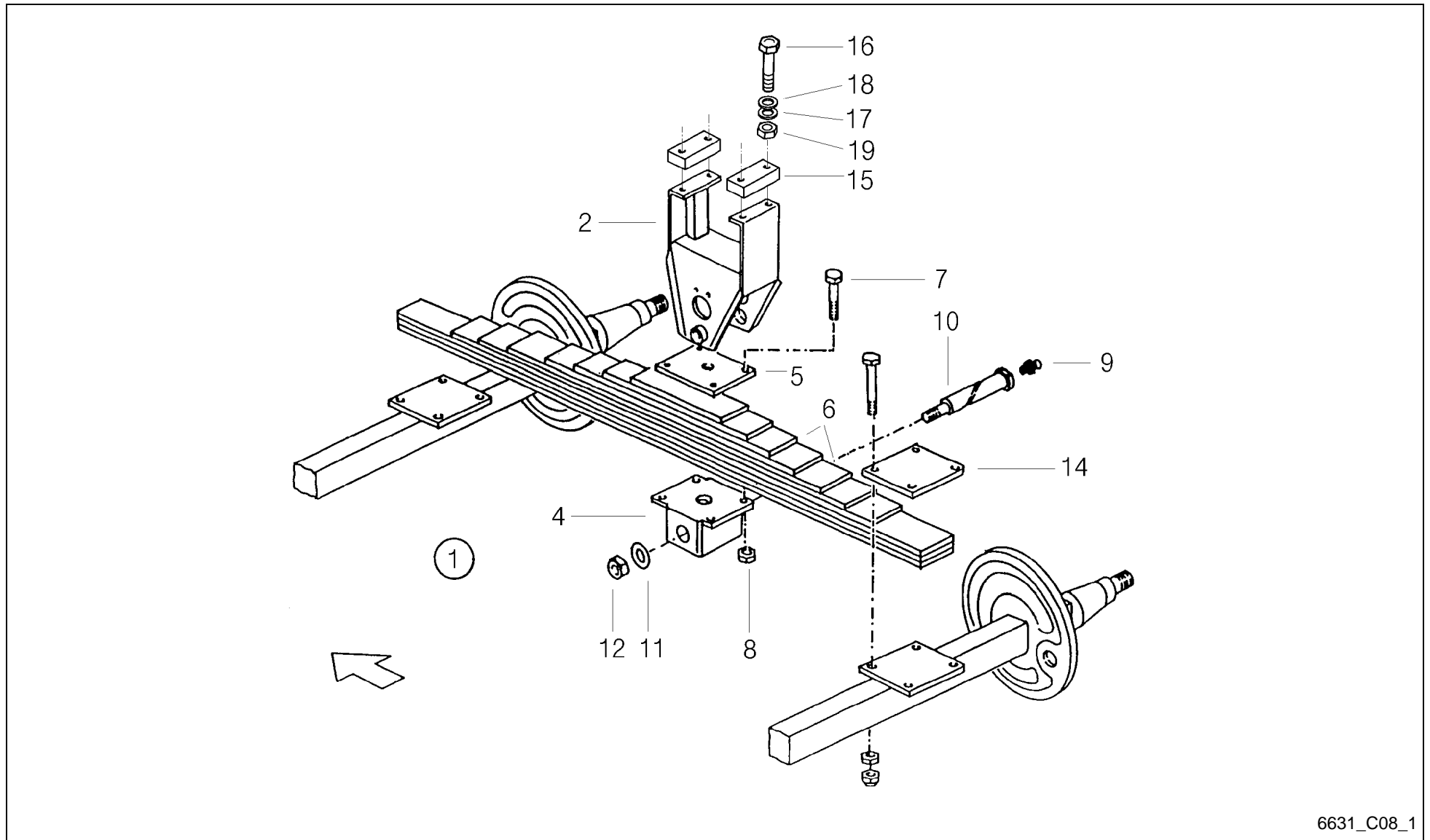

6631_C08_1

Feedex 360 T / ASSEMBLY PENDULAR



PosNo.	Part No.	Qty.	Description	Remark
1	VF16630104	1	ASSEMBLY PENDULAR	S C09/1
2	VF16630100	2	AXLE BRACKET	
4	VF16518869	2	SPRING SEAT	
5	VF16513257	2	PLATE	
6	VF16630232	2	LEAF SPRING	bei Ersatz paarweise wechseln
7	VF06209168	8	BOLT	
8	VF06209774	8	LOCK NUT	
9	VF01120694	2	GREASE NIPPLE	
10	VF16518871	2	ANCHOR PIN	
11	VF16518150	2	WASHER/DISC/PLATE	
12	VF01397661	2	HEX.NUT	
14	VF16513259	4	PLATE	
15	A143039786	4	SHIM	bei Bereifung 500/50/17
16	VF06273759	8	HEX. HEAD SCREW	bei Bereifung 500/50/17
17	VF01142556	8	SPACING RING	bei Bereifung 500/50/17
18	VF06214220	8	WASHER 17X34X3 GALV.	bei Bereifung 500/50/17
19	VF01127856	8	LOCK NUT	bei Bereifung 500/50/17

Feedex 360 T / SPRING BORN TENDEM AXLE (8TO.)

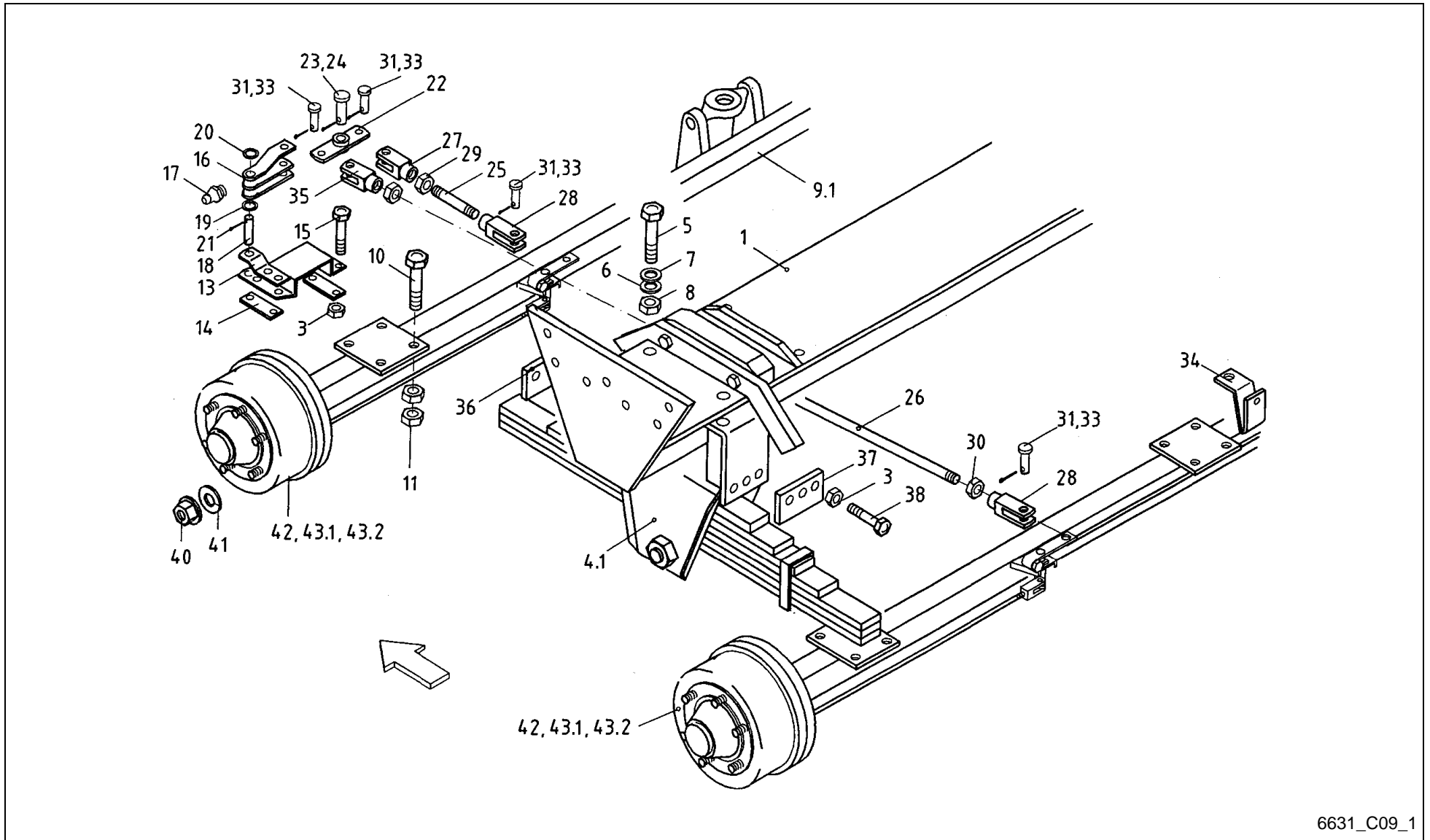

6631_C09_1



Feedex 360 T / SPRING BORN TENDEM AXLE (8TO.)

PosNo.	Part No.	Qty.	Description	Remark
1	VF16611492	1	AXLE CARRIER	
3	VF06209778	24	LOCK NUT	
4.1	VF16630104	1	ASSEMBLY PENDULAR	S C08/1
5	VF01111861	8	HEX.BOLT	
6	VF01142556	8	SPACING RING	
7	VF06214220	8	WASHER 17X34X3 GALV.	
8	VF01127856	8	LOCK NUT	
9.1	VF16630397	2	BRAKE AXLE	S C27 Rückmatik
10	VF06273759	16	HEX. HEAD SCREW	
11	VF01112886	32	HEX. NUT	
13	VF16516363	1	SUPPORT PLATE	
14	VF16516380	2	CONNECTING PLATE	
15	VF01111562	4	HEX.HEAD SCREW	
16	VF16516368	1	LEVER/ARM	
17	VF01120692	1	GREASE NIPPLE H1 AM 6X1 DIN 71412	
18	VF06209952	1	PIN/BOLT/STUD	
19	VF06214229	2	WASHER 21X32X2 GALV.	
20	VF06214226	2	WASHER	
21	VF01122072	2	SPLIT PIN	
22	VF16516374	1	BRAKE COMP.DEV.	
23	VF01139468	1	PIN	
24	VF01106451	1	SPLIT PIN	
25	VF16516500	1	PULLROD	
26	A143031663	1	PULLROD L=1200	
27	VF01123290	1	CLEVIS	
28	VF01120915	3	FORK HEAD	
29	VF01112850	1	HEX. HEAD SCREW	
30	VF01102659	3	HEX. NUT	
31	VF06210009	4	PIN	
33	VF01132625	4	SPLIT PIN	
34	VF16516512	2	RETAINER	
36	VF16516398	2	STOP	
37	VF16511646	2	STOP	
38	VF01111475	12	HEX. HEAD SCREW	
40	VF01121797	24	FLAT-COLLAR NUT	
41	VF01121808	24	SPRING LOCKWASHER	
42	VF16630078	2	BRAKE AXLE	S C28 Druckluft
43.1	VF16630080	2	BRAKING SPINDLE	S C25 Hydraulik
43.2	VF16631886	2	ACHSE BREIT	Bauvariante S C20-x

Feedex 360 T / ASSORTMENT OF WHEEL

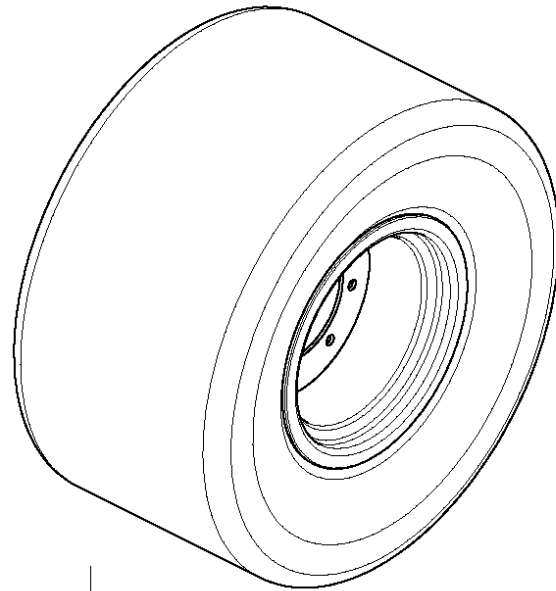

11, 12, 13, 14, 15

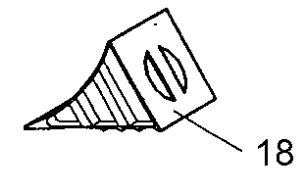
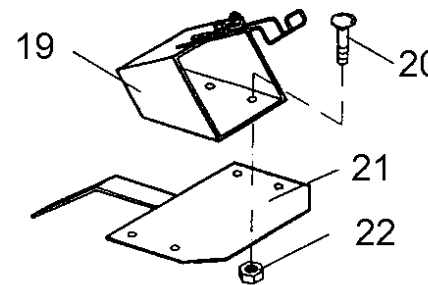

6631_C10



Feedex 360 T / ASSORTMENT OF WHEEL

PosNo.	Part No.	Qty.	Description	Remark
11	VF16512621	4	WHEEL	Tandem
11.1	VF16512621	2	WHEEL	Single
12	VF01397605	4	GEAR/WHEEL	Tandem
12.1	VF01397605	2	GEAR/WHEEL	Single
13	A143014600	4	WHEEL	Tandem -A 2016
13.1	A143014600	2	WHEEL	Single -A 2016
14	A143014300	2	WHEEL	Single
15	A143037800	4	WHEEL	Tandem +A 2017
15.1	A143037800	2	WHEEL	Single +A 2017
18	VF16630072	2	STOP-BLOCK	
19	VF16630070	2	SUPPORT	
20	VF01137624	8	SCREW	
21	VF16630069	2	SUPPORT	
22	VF01104944	8	NY LOCK NUT 8A3CD985	

Feedex 360 T / BRAKE CABLE TAN. AXLE AUTOREVERSE

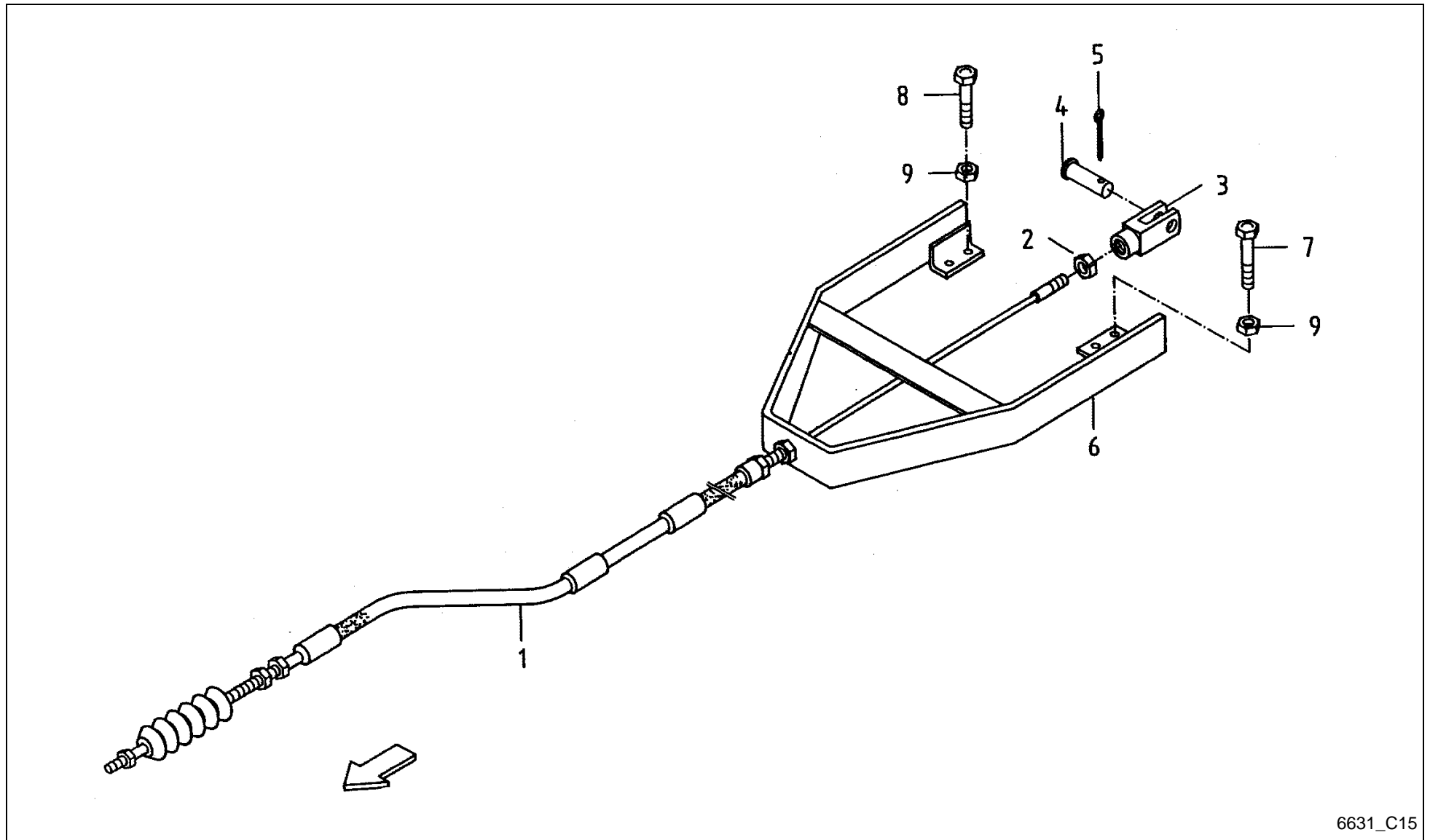

6631_C15

Feedex 360 T / BRAKE CABLE TAN. AXLE AUTOREVERSE



PosNo.	Part No.	Qty.	Description	Remark
1	VF16611497	1	BRAKE CABLE	
2	VF01112858	1	NUT	
3	VF01120923	1	FORK	
4	VF06210014	1	PIN	
5	VF01106447	1	SPLIT PIN	
6	VF16613248	1	RETAINER	
7	VF01112538	2	HEX.HEAD SCREW	
8	VF01112529	2	HEX.HEAD SCREW	
9	VF06209769	4	LOCK NUT	

Feedex 360 T / HANDBRAKE TAND AXLE SPR BORN PRESS AIR BRAKE

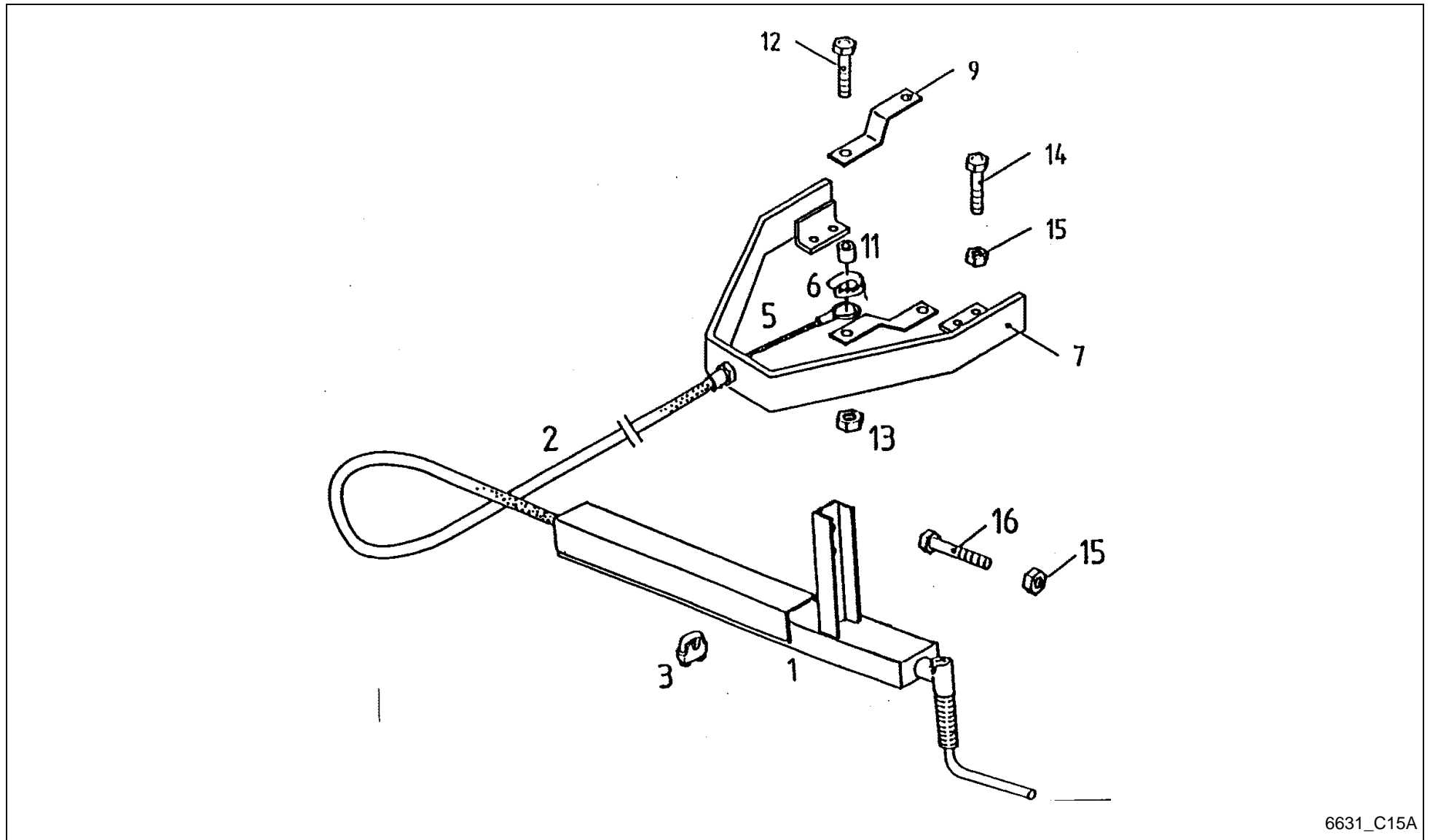

6631_C15A

Feedex 360 T / HANDBRAKE TAND AXLE SPR BORN PRESS AIR BRAKE



PosNo.	Part No.	Qty.	Description	Remark
1	VF16516507	1	PARKING BRAKE	
2	VF06558917	1	CABLE HOSE	
3	VF01136686	2	CABEL CLAMP S 5 DIN1142- GALV.	
5	VF16513859	1	BRAKE CABLE	
6	VF01139169	1	THIMBLE B 5 DIN6899- GALV.	
7	VF16516382	1	YOKE/RETAINER	
9	VF16513860	2	LASCHE	
11	VF16513861	1	BUSH	
12	VF01112429	1	HEX. HEAD SCREW	
13	VF06209768	1	LOCK NUT	
14	VF01112538	4	HEX.HEAD SCREW	
15	VF06209769	6	LOCK NUT	
16	VF01112529	2	HEX.HEAD SCREW	

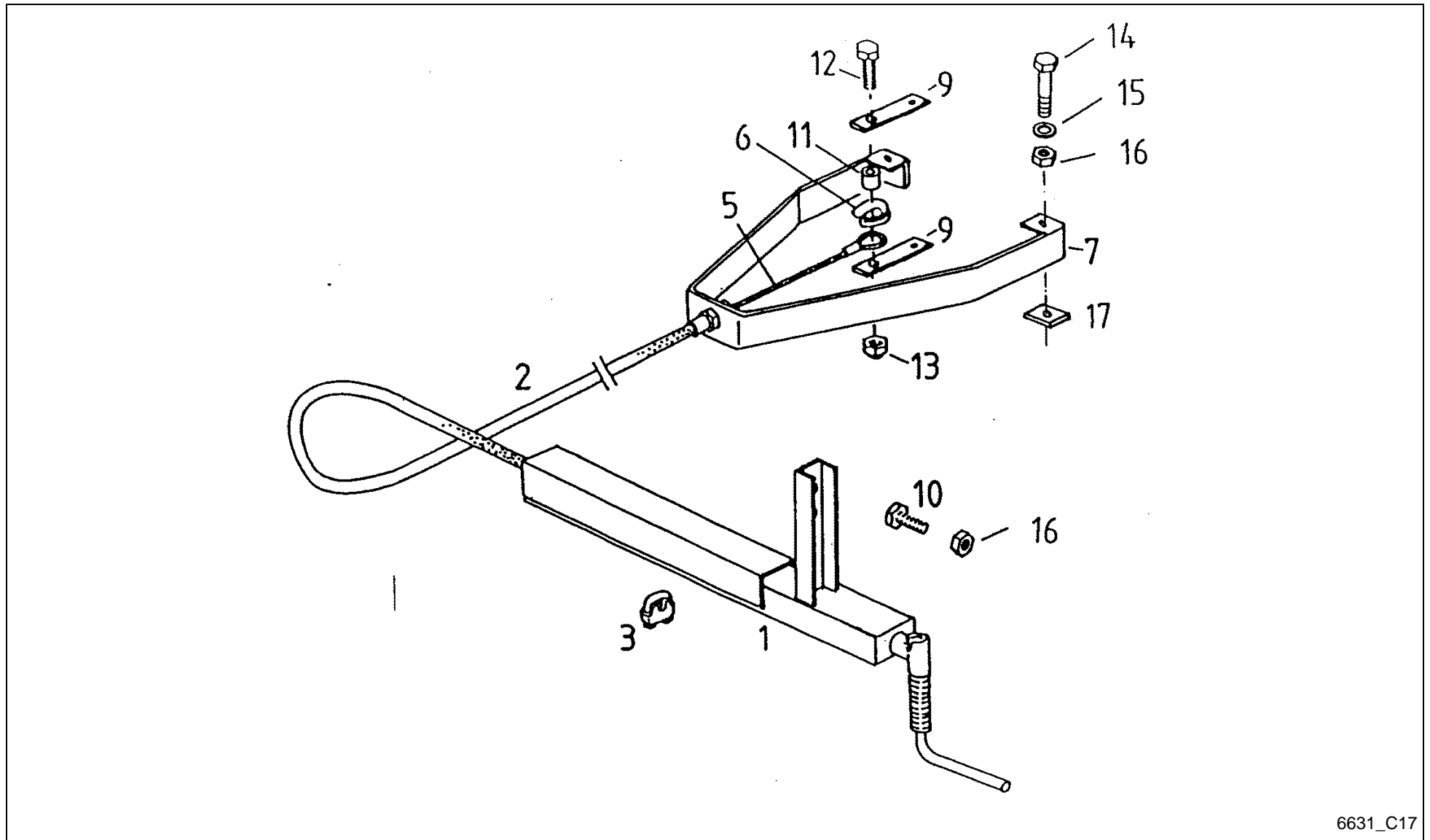

6631_C17

Feedex 360 T / HANDBRAKE TAND.AXLE 9TO.2 BRAKES HYDR.



PosNo.	Part No.	Qty.	Description	Remark
1	VF16516507	1	PARKING BRAKE	
2	VF06558917	1	CABLE HOSE	
3	VF01136686	2	CABEL CLAMP S 5 DIN1142- GALV.	
5	VF16513859	1	BRAKE CABLE	
6	VF01139169	1	THIMBLE B 5 DIN6899- GALV.	
7	VF16513686	1	YOKE/RETAINER	
9	VF16516440	2	CONNECTING PLATE	
10	VF01112529	2	HEX.HEAD SCREW	
11	VF16516441	1	SPACER TUBE	
12	VF01111308	1	HEX. HEAD SCREW	
13	VF06209768	1	LOCK NUT	
14	KG00357500	2	HEX. BOLT M12X50 8.8	
15	VF06214206	2	WASHER 13X30X4 RM=580-680 MPA A2C	
16	VF06209769	2	LOCK NUT	
17	VF16516442	2	SHIM	

Feedex 360 T / BRAKE HYDRAULIC (FANCE)

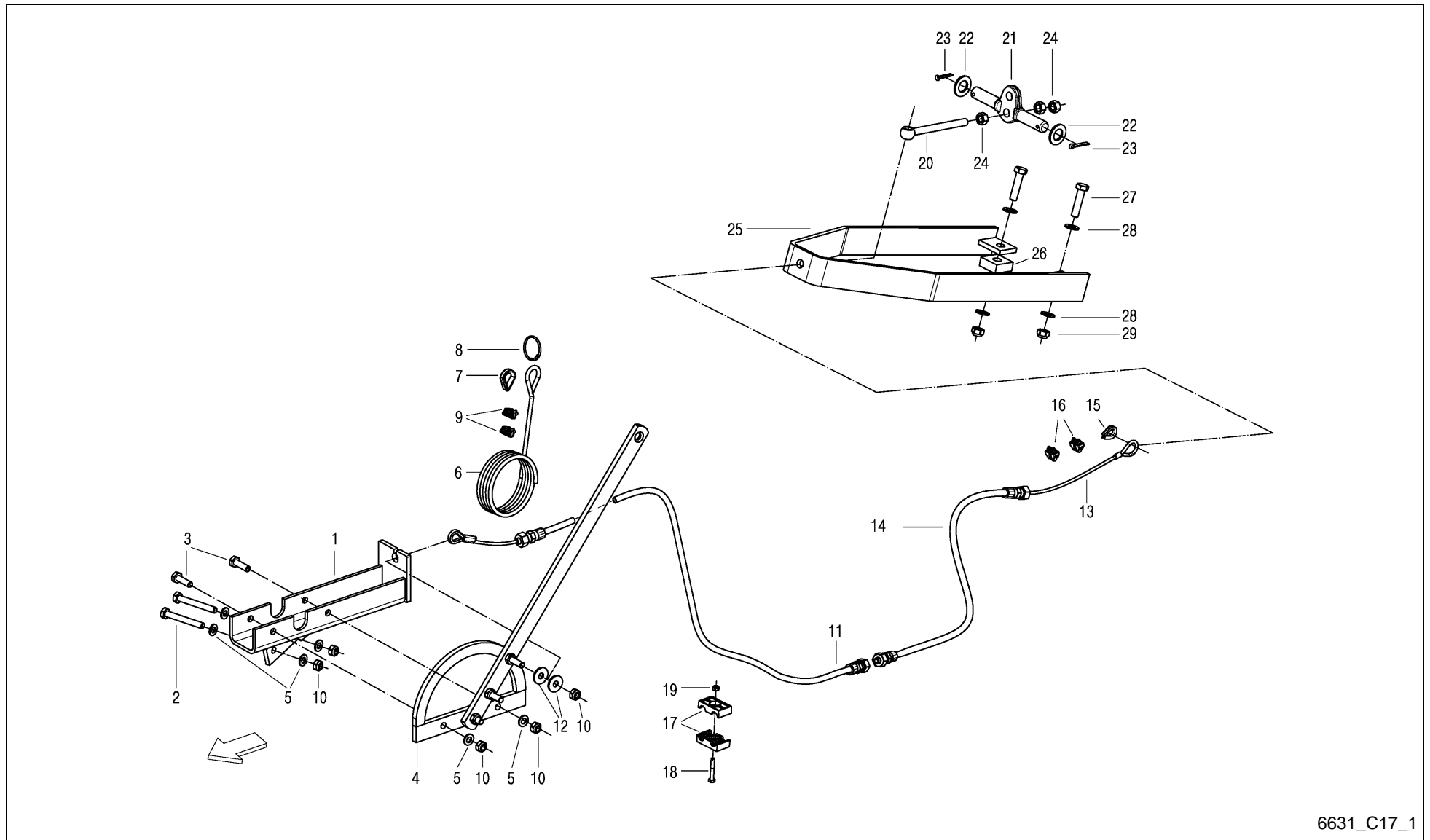

6631_C17_1



Feedex 360 T / BRAKE HYDRAULIC (FANCE)

PosNo.	Part No.	Qty.	Description	Remark
1	VF16635241	1	CONSOLE	
2	VF01111339	2	HEX. HEAD SCREW	
3	VF01112439	2	HEX. HEAD SCREW	
4	VF16631482	1	HAND BRAKE LEVER	
5	VF01107165	4	WASHER M10 11X20X2 A2C DIN126	
6	VF06587631	1	CABLE	
7	VF01137837	1	THIMBLE	
8	VNB3469202	1	SAFETY RING	
9	VF01136687	1	CLAMPING PIECE	
10	VF06209768	8	LOCK NUT	
11	VF06558733	1	CABLE HOSE	
12	VF06214197	2	WASHER 10,5X30X3 GALV.	
13	VF06558728	1	BRAKE CABLE	
14	VF16518193	1	CABLE HOSE	
15	VF01139169	2	THIMBLE B 5 DIN6899- GALV.	
16	VF01136686	2	CABEL CLAMP S 5 DIN1142- GALV.	
17	VF06578035	2	CLAMP	
18	VF01111071	1	HEX. HEAD SCREW	
19	VF01114357	1	LOCK NUT	
20	VF06207186	1	EYEBOLT	
21	VF03.110.02.140	1	BRAKE BALANCE	
22	VF06214226	2	WASHER	
23	VF01122072	2	SPLIT PIN	
24	VF01125801	3	HEX. NUT	
25	VF16635269	1	YOKE	
26	VF16516442	2	SHIM	
27	VF01111486	2	HEXAGON HEAD SCREW M12X50 DIN 931 8.8	
28	VF06214206	4	WASHER 13X30X4 RM=580-680 MPA A2C	
29	VF06209769	2	LOCK NUT	

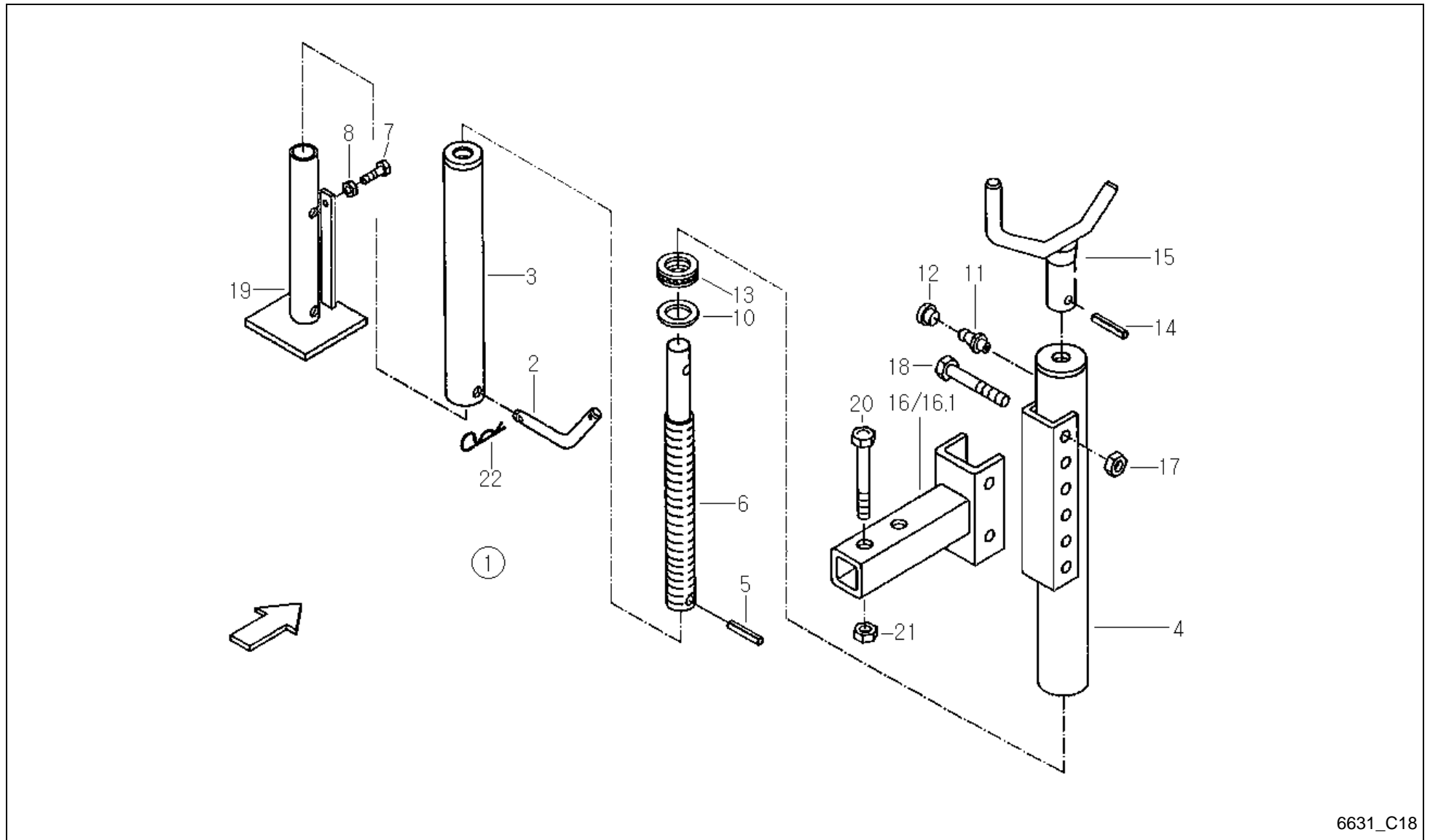

Feedex 360 T / PARKING STAND (-A 2016)



PosNo.	Part No.	Qty.	Description	Remark
1	VF16613267	1	PRASED PARTS	
2	VF16614473	1	BOLT	
3	VF16614474	1	INNER TUBE	
4	VF16614475	1	EXTERNAL TUBE	
5	KG01185862	2	TENSION PIN 4X16	
6	VF16614480	1	SPINDLE	
7	VF01112307	1	HEX. HEAD SCREW	
8	VF01112824	1	HEX. NUT	
10	VF01141047	1	WASHER 21,0X44,0X5,0	
11	VF01120693	1	GREASE FITTING H1 AM 8X1 DIN 71412	
12	VF16514101	1	PLUG	
13	VF01109886	1	GR. BALL BEARING	
14	VF01115457	1	DOWEL PIN	
15	VF16614479	1	CRANK HANDLE	
16	VF16614478	1	RETAINER	-A 2006
16.1	VF16631486	1	RETAINER	+A 2007
17	VF06209774	2	LOCK NUT	
18	VF01139339	2	HEX.BOLT	
19	VF16614472	1	SUPPORT	
20	VF16630548	1	HEXAGON HEAD SCREW M16X130 D931 10.9	
21	VF01127856	1	LOCK NUT	
22	VF06215671	1	PIN	

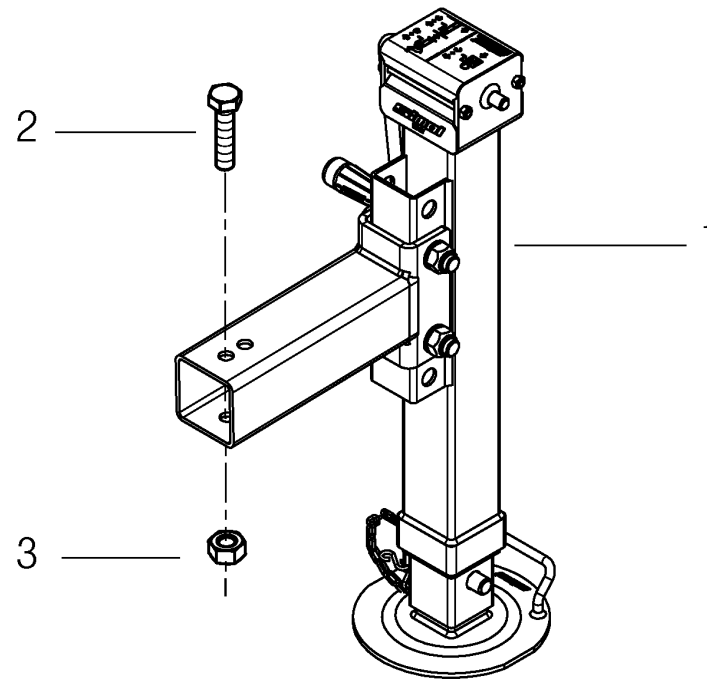

Feedex 360 T / PARKING STAND (+A 2017)



PosNo.	Part No.	Qty.	Description	Remark
1	A143039830	1	SUPPORT	
2	VF01111941	1	HEX.BOLT	
3	VF01127856	1	LOCK NUT	

Feedex 360 T / BRAKE AXLE TANDEM HYDRAULIC TRACK 2000 (constructive variant)

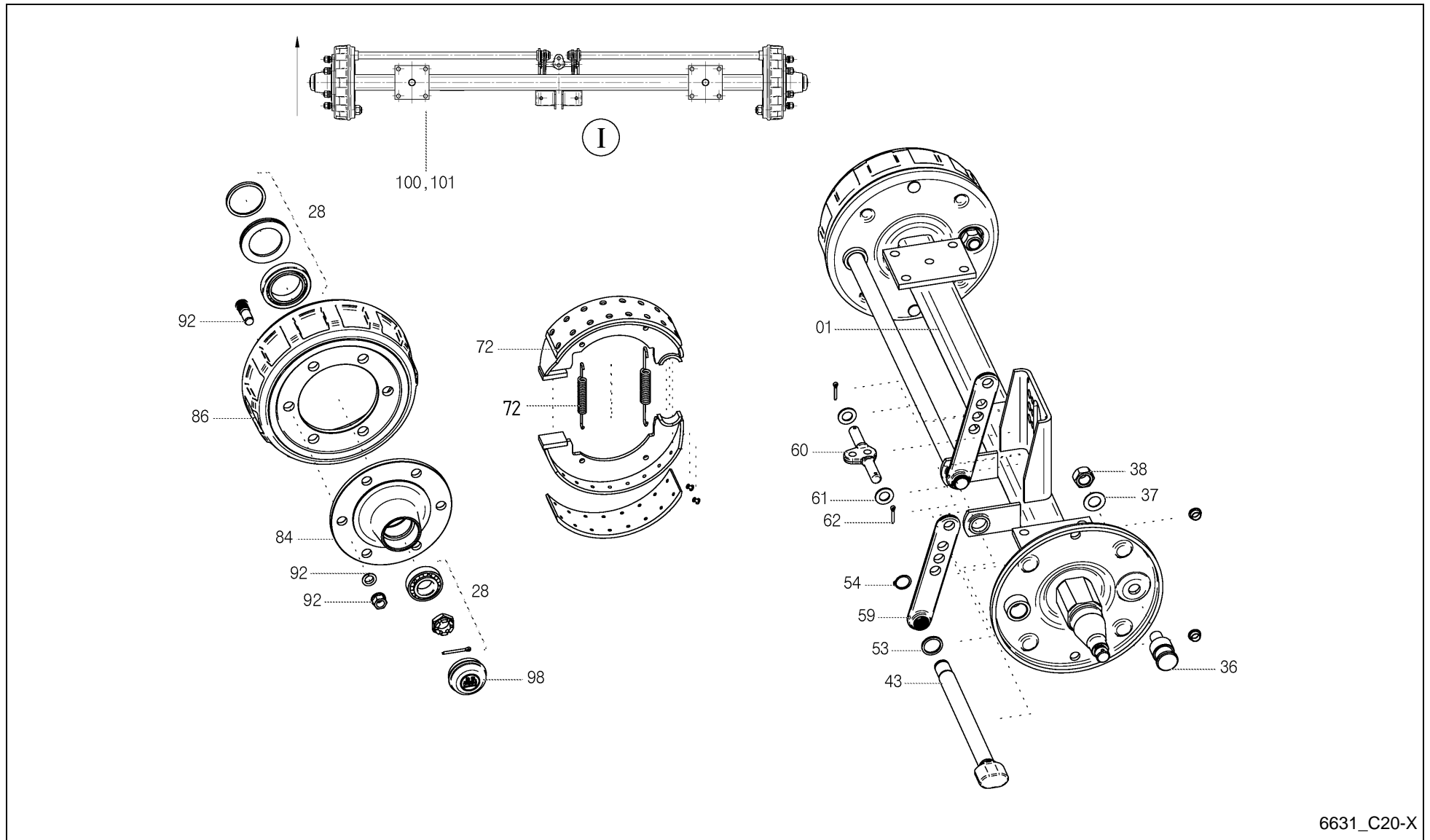

6631_C20-X

Feedex 360 T / BRAKE AXLE TANDEM HYDRAULIC TRACK 2000 (constructive variant)



PosNo.	Part No.	Qty.	Description	Remark
I	VF16631886	1	ACHSE BREIT	
1	A143507300	1	AXLE BODY, GROUP	
28	A143503000	1	STORAGE PARTS SETS	
36	VF16602599	2	THREADED PIN	
37	VF16602600	2	WASHER	
38	A143503100	2	LOCK NUT VM24X1,5 DIN980	
43	A143507400	2	BRAKE CAMSHAFT L=925 / A=838	
53	A143503300	2	RING 42/34X4	
54	VF16618627	2	CIRCLIP	
59	A143503400	2	BRAKE LEVER	
60	VF03.110.02.140	1	BRAKE BALANCE	
61	A143475200	2	WASHER 21 DIN125	
62	VF01122071	2	SPLIT PIN 5,0X28 DIN94 A3C	
72	A143503600	1	BRAKE SHOE SET, KIT	
84	VF16617329.86	2	WHEEL HUB	
86	VF16617330.86	2	BRAKE DRUM	
92	A143503700	12	WHEEL STUD SET M18X57	
98	VF16612405	2	WHEEL CAP	
100	VF06273759	8	HEX. HEAD SCREW	
101	VF01112886	16	HEX. NUT	

Feedex 360 T / BRAKE AXLE TANDEM HYDRAULIC ()

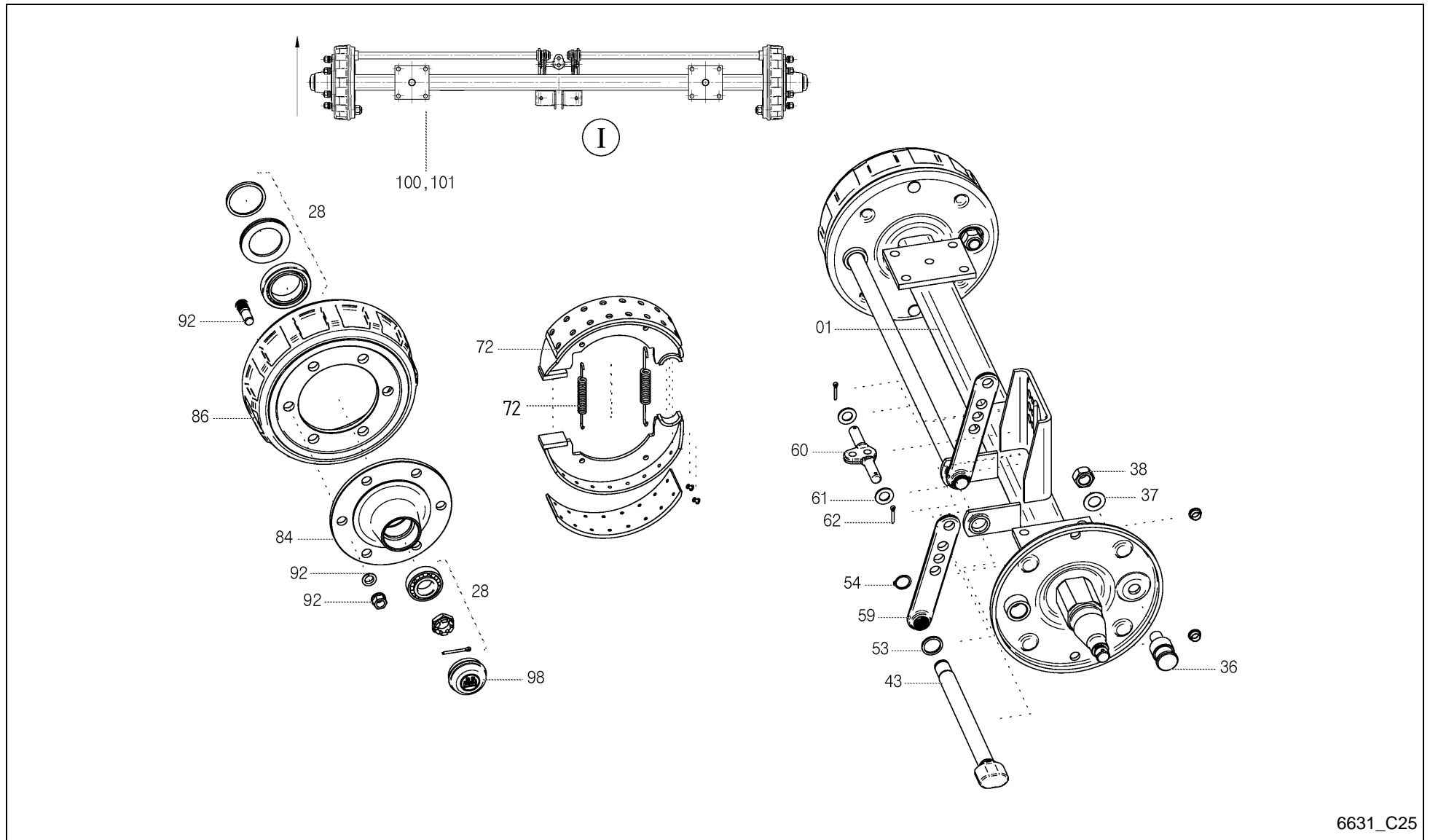

6631_C25



Feedex 360 T / BRAKE AXLE TANDEM HYDRAULIC ()

PosNo.	Part No.	Qty.	Description	Remark
I	VF16630080	1	BRAKING SPINDLE	
1	A143502900	1	AXLE BODY, GROUP	
28	A143503000	1	STORAGE PARTS SETS	
36	VF16602599	2	THREADED PIN	
37	VF16602600	2	WASHER	
38	A143503100	2	LOCK NUT VM24X1,5 DIN980	
43	A143503200	2	BRAKE CAMSHAFT L=750 / A=663	
53	A143503300	2	RING 42/34X4	
54	VF16618627	2	CIRCLIP	
59	A143503400	2	BRAKE LEVER	
60	VF03.110.02.140	1	BRAKE BALANCE	
61	A143475200	2	WASHER 21 DIN125	
62	VF01122071	2	SPLIT PIN 5,0X28 DIN94 A3C	
72	A143503600	1	BRAKE SHOE SET, KIT	
84	VF16617329.86	2	WHEEL HUB	
86	VF16617330.86	2	BRAKE DRUM	
92	A143503700	12	WHEEL STUD SET M18X57	
98	VF16612405	2	WHEEL CAP	
100	VF06273759	8	HEX. HEAD SCREW	
101	VF01112886	16	HEX. NUT	

Feedex 360 T / BRAKE AXLE TANDEM AUTOREVERSE ()

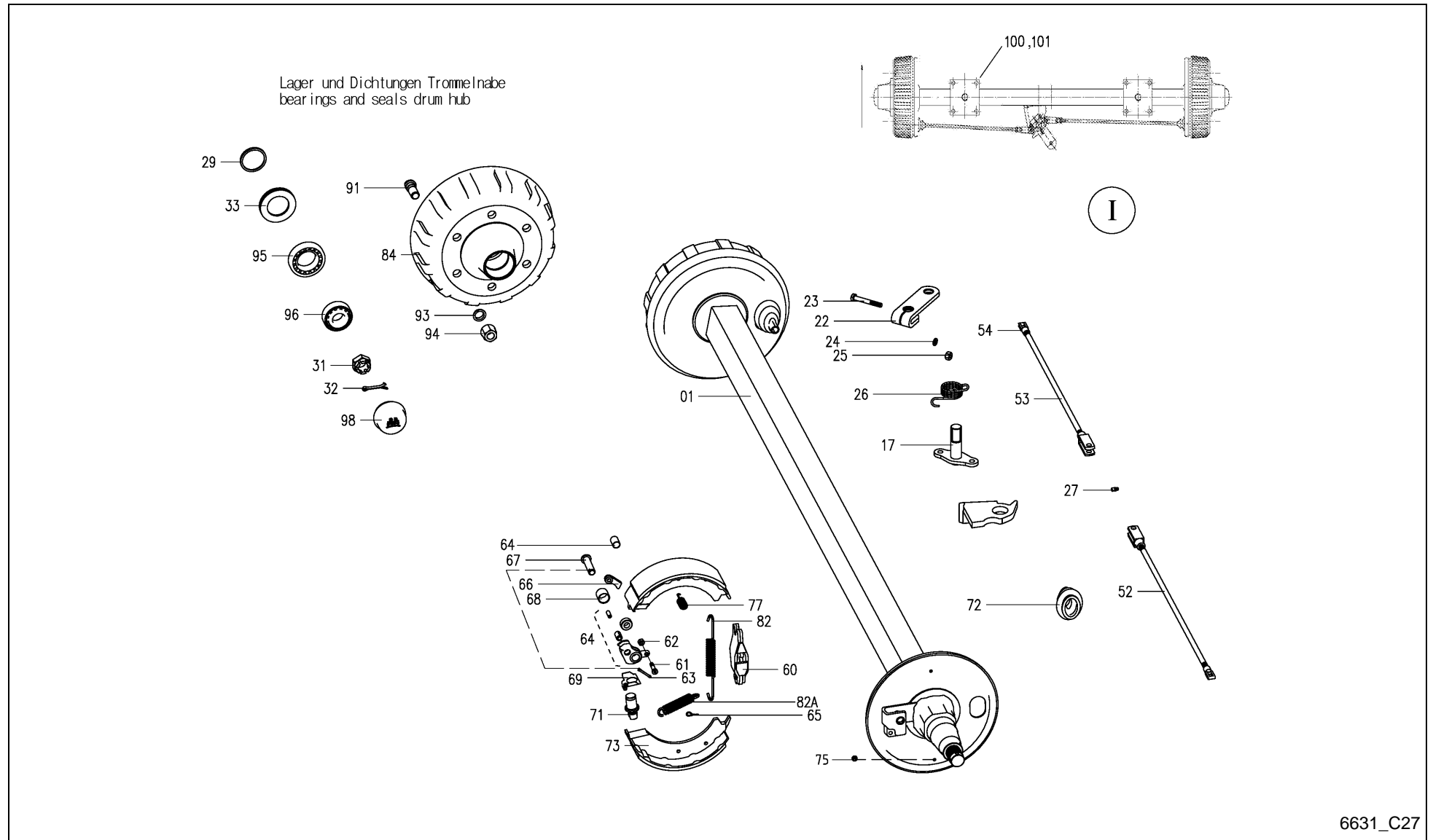

6631_C27



Feedex 360 T / BRAKE AXLE TANDEM AUTOREVERSE ()

PosNo.	Part No.	Qty.	Description	Remark
I	VF16630397	1	BRAKE AXLE	
1	A143506300	1	AXLE BODY, GROUP	
17	VF16612429	1	LEVER/ARM	
22	VF16612438	1	YOKE/RETAINER	
23	A143485400	1	HEXAGON HEAD SCREW M10X65 DIN931	
24	VF16612430	2	WASHER/DISC/PLATE	
25	A143507600	1	HEXAGONAL NUT M10 DIN934	
26	A143506400	1	SPRING	
27	VF16602619	1	GREASE NIPPLE	
27A	VF16602606	1	PROTECTING CAP	
29	VF16602597	2	RING	
31	VF16612406	2	CASTLE NUT	
32	A143507700	2	SPLIT PIN 5X45 ISO1234	
33	VF16602598	2	SEAL RING	
52	A143506500	1	BRAKE BAR GROUP L=590	
53	A143506600	1	BRAKE BAR GROUP L=715	
54	VF16618679	2	YOKE	
60	A143504300	2	LOCK EXPANDED	
61	A143504400	2	SCREW M8X35 DIN 7984	
62	A143459000	2	LOCK NUT M8 DIN985	
63	A143472600	2	SPLIT PIN 4X25 ISO1234	
64	A143504500	2	LEVER	
65	A143504700	4	FUSE	
66	A143504800	2	LEVER	
67	A143504900	2	BOLT B16X65 ISO2341	
68	A143505000	2	BUSH	
69	A143505200	2	FUSE	
71	A143505500	2	ADJUSTING NUT	
72	VF16503949	2	BELLOWS	
73	VF16612412	4	BRAKE SHOE	
75	A143458700	4	PLUG GPN 300 F5 M12	
77	A143505800	4	COMPRESSION SPRING	
81	A143505900	1	TENSION SPRING	
82	VF16503935	1	DRAW SPRING	
82A	A143506000	2	TENSION SPRING	
84	A143506100	2	DRUM HUB	
91	A143506200	12	WHEEL STUD M18X1,5X52	
93	VF16618602	12	SPRING WASHER	
94	VF16618603	12	FLAT-COLLAR NUT	
95	VF16602614	2	TAPER ROLLER BEARING.	

Feedex 360 T / BRAKE AXLE TANDEM AUTOREVERSE ()

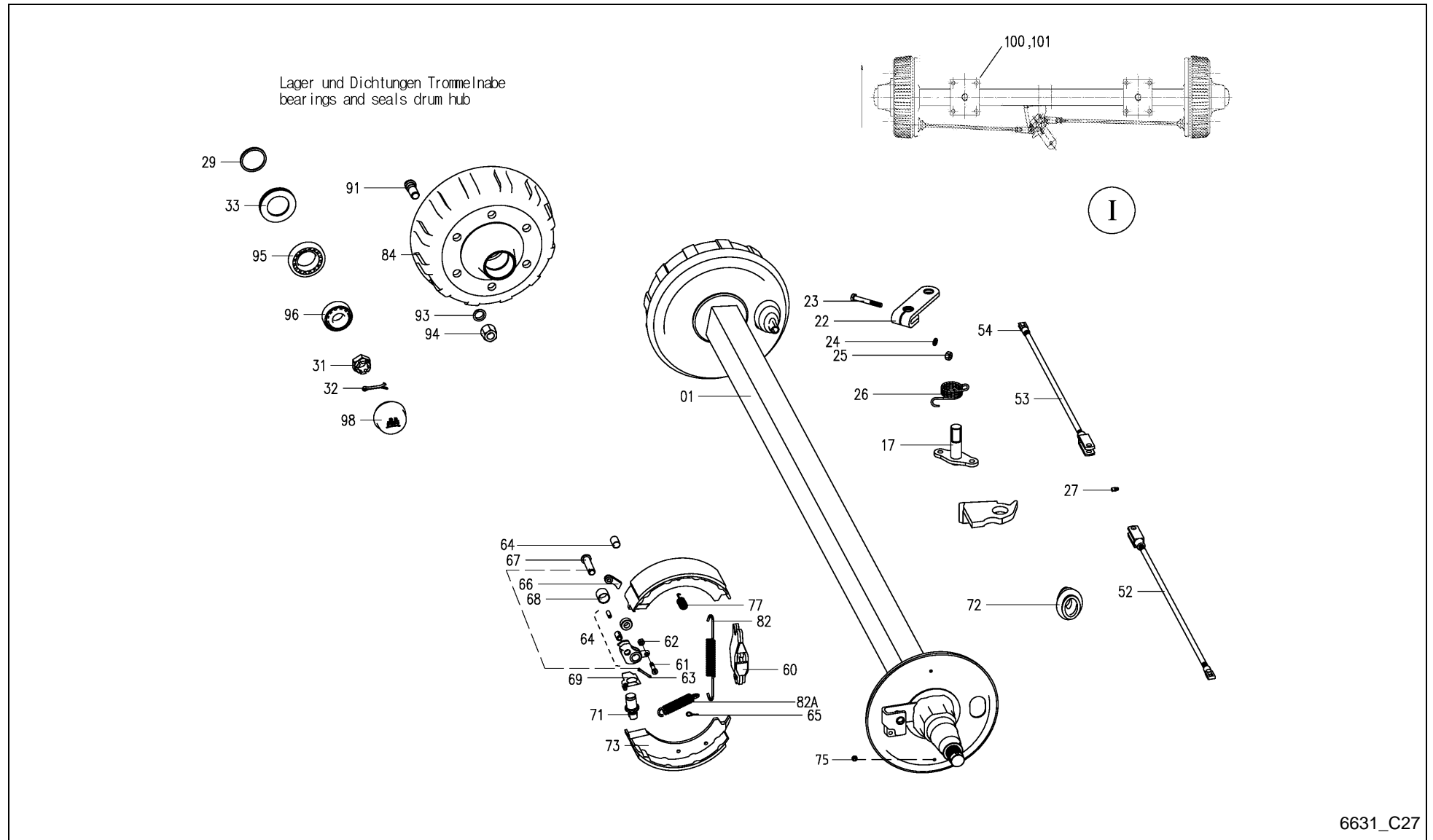

6631_C27

Feedex 360 T / BRAKE AXLE TANDEM AUTOREVERSE ()



PosNo.	Part No.	Qty.	Description	Remark
96	A143503800	2	TAPER ROLLER BEARING 30207	
98	VF16612405	2	WHEEL CAP	
100	VF06273759	8	HEX. HEAD SCREW	
101	VF01112886	16	HEX. NUT	

Feedex 360 T / BRAKE AXLE TANDEM PRESS AIR ()

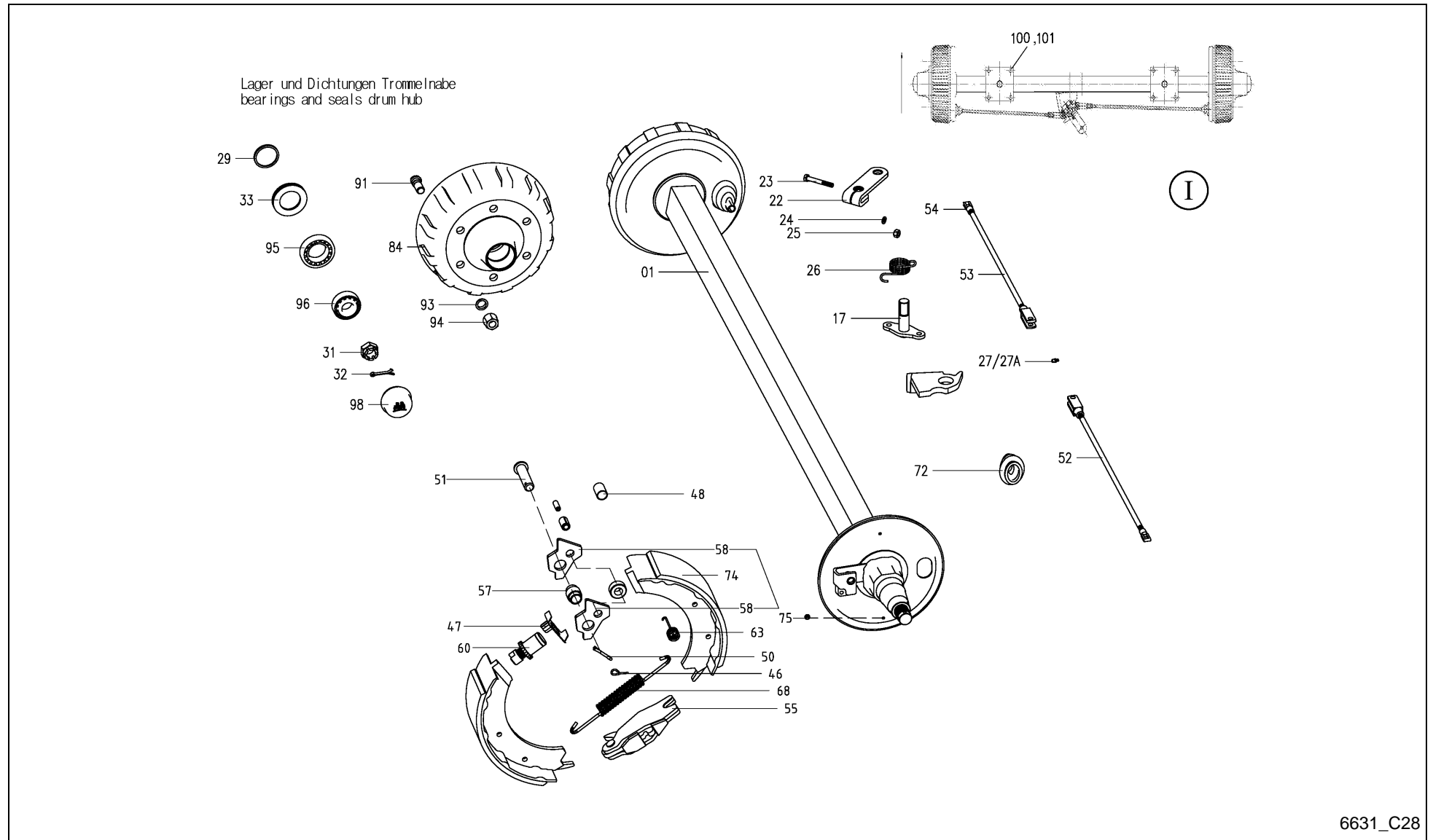

6631_C28



Feedex 360 T / BRAKE AXLE TANDEM PRESS AIR ()

PosNo.	Part No.	Qty.	Description	Remark
I	VF16630078	1	BRAKE AXLE	
1	A143506700	1	AXLE BODY, GROUP	
17	VF16612429	1	LEVER/ARM	
22	A143506800	1	BRAKE LEVER L100	
23	A143485400	1	HEXAGON HEAD SCREW M10X65 DIN931	
24	VF16612430	2	WASHER/DISC/PLATE	
25	A143507600	1	HEXAGONAL NUT M10 DIN934	
26	A143506400	1	SPRING	
27	VF16602619	1	GREASE NIPPLE	
27A	VF16602606	2	PROTECTING CAP	
29	VF16602597	2	RING	
31	VF16612406	2	CASTLE NUT	
32	A143507700	2	SPLIT PIN 5X45 ISO1234	
33	VF16602598	2	SEAL RING	
46	A143504700	2	FUSE	
47	A143505200	1	FUSE	
48	A143505000	1	BUSH	
50	A143472600	1	SPLIT PIN 4X25 ISO1234	
51	A143504900	1	BOLT B16X65 ISO2341	
52	A143506500	1	BRAKE BAR GROUP L=590	
53	A143506600	1	BRAKE BAR GROUP L=715	
54	VF16618679	2	YOKE	
55	A143504300	1	LOCK EXPANDED	
57	A143506900	1	BUSH	
58	A143507000	1	LEVER	
60	A143505500	1	ADJUSTING NUT	
63	A143505800	2	COMPRESSION SPRING	
65	A143458700	2	PLUG GPN 300 F5 M12	
68	A143505900	1	TENSION SPRING	
68A	VF16503935	1	DRAW SPRING	
72	VF16503949	1	BELLOWS	
74	VF16612412	2	BRAKE SHOE	
84	A143506100	2	DRUM HUB	
91	A143506200	12	WHEEL STUD M18X1,5X52	
93	VF16618602	12	SPRING WASHER	
94	VF16618603	12	FLAT-COLLAR NUT	
95	VF16602614	2	TAPER ROLLER BEARING.	
96	A143503800	2	TAPER ROLLER BEARING 30207	
98	VF16612405	2	WHEEL CAP	
100	VF06273759	1	HEX. HEAD SCREW	

Feedex 360 T / BRAKE AXLE TANDEM PRESS AIR ()

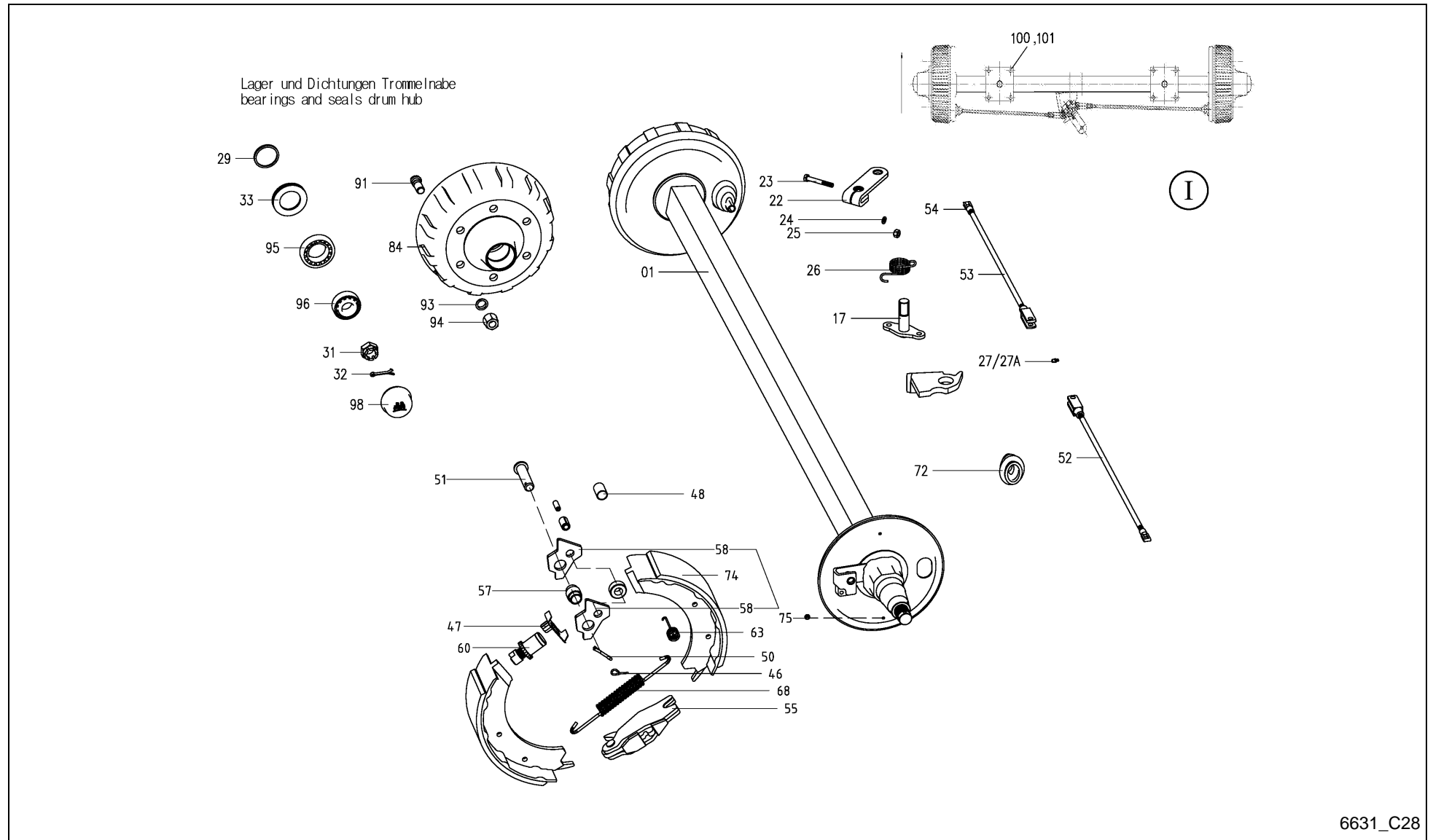

6631_C28

Feedex 360 T / BRAKE AXLE TANDEM PRESS AIR ()



PosNo.	Part No.	Qty.	Description	Remark
101	VF01112886	1	HEX. NUT	

Feedex 360 T / TANDEM-WHEEL AXLE HYDRAULIC ()

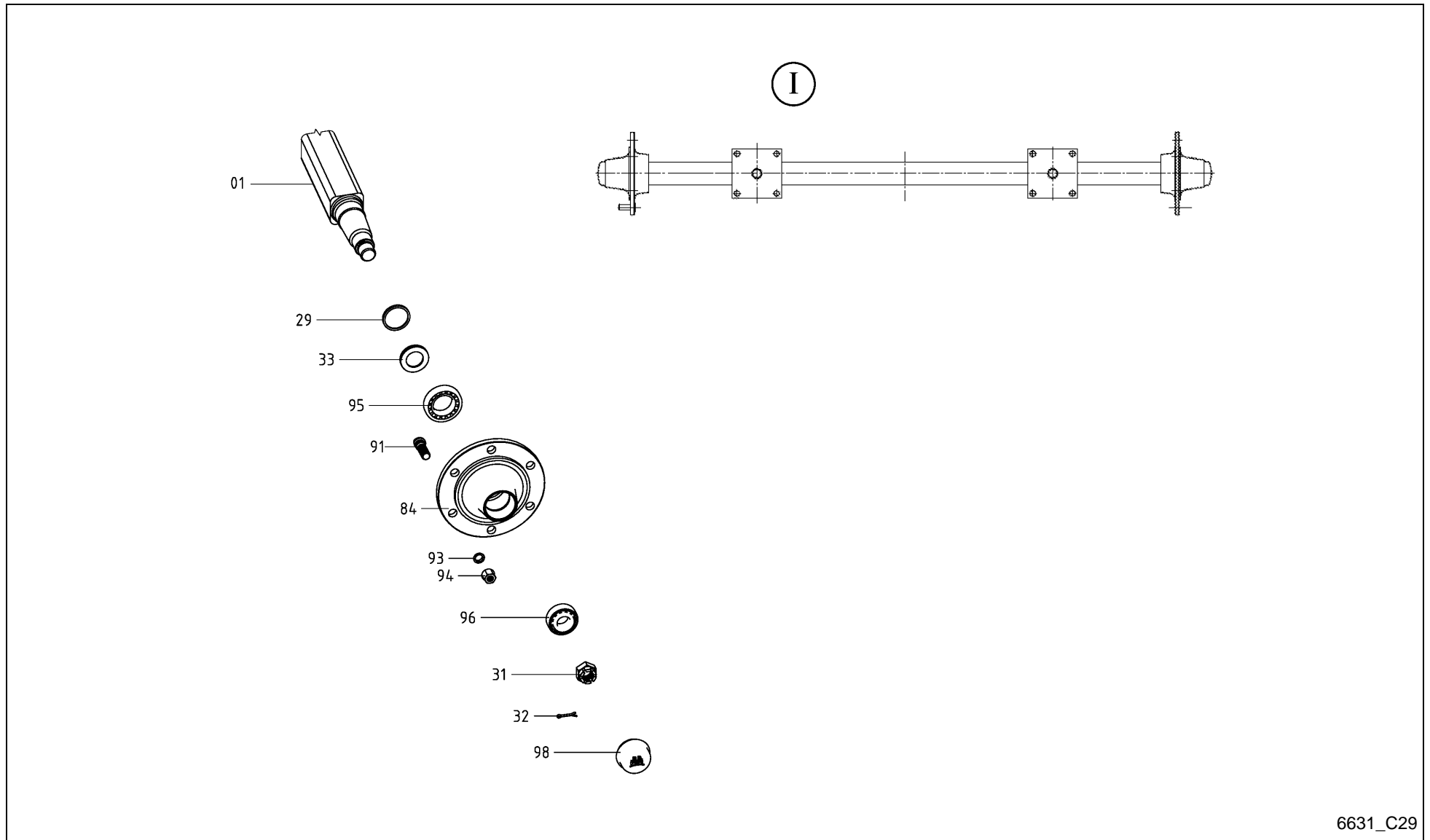

6631_C29

Feedex 360 T / TANDEM-WHEEL AXLE HYDRAULIC ()



PosNo.	Part No.	Qty.	Description	Remark
I	VF16630075	1	WHEEL AXLE	
1	A143507200	1	AXLE BODY,	
29	VF16602597	1	RING	
31	VF16612406	2	CASTLE NUT	
32	A143507700	2	SPLIT PIN 5X45 ISO1234	
33	VF16602598	2	SEAL RING	
84	VF16617329.86	2	WHEEL HUB	
91	A143507100	12	WHEEL STUD M18X1,5X46	
93	VF16618602	12	SPRING WASHER	
94	VF16618603	12	FLAT-COLLAR NUT	
95	VF16602614	2	TAPER ROLLER BEARING.	
96	A143503800	2	TAPER ROLLER BEARING 30207	
98	VF16612405	2	WHEEL CAP	

Feedex 360 T / HYDR. BRAKE SYSTEM FOR TANDEM AXLE 2-WHEELS BRAKED

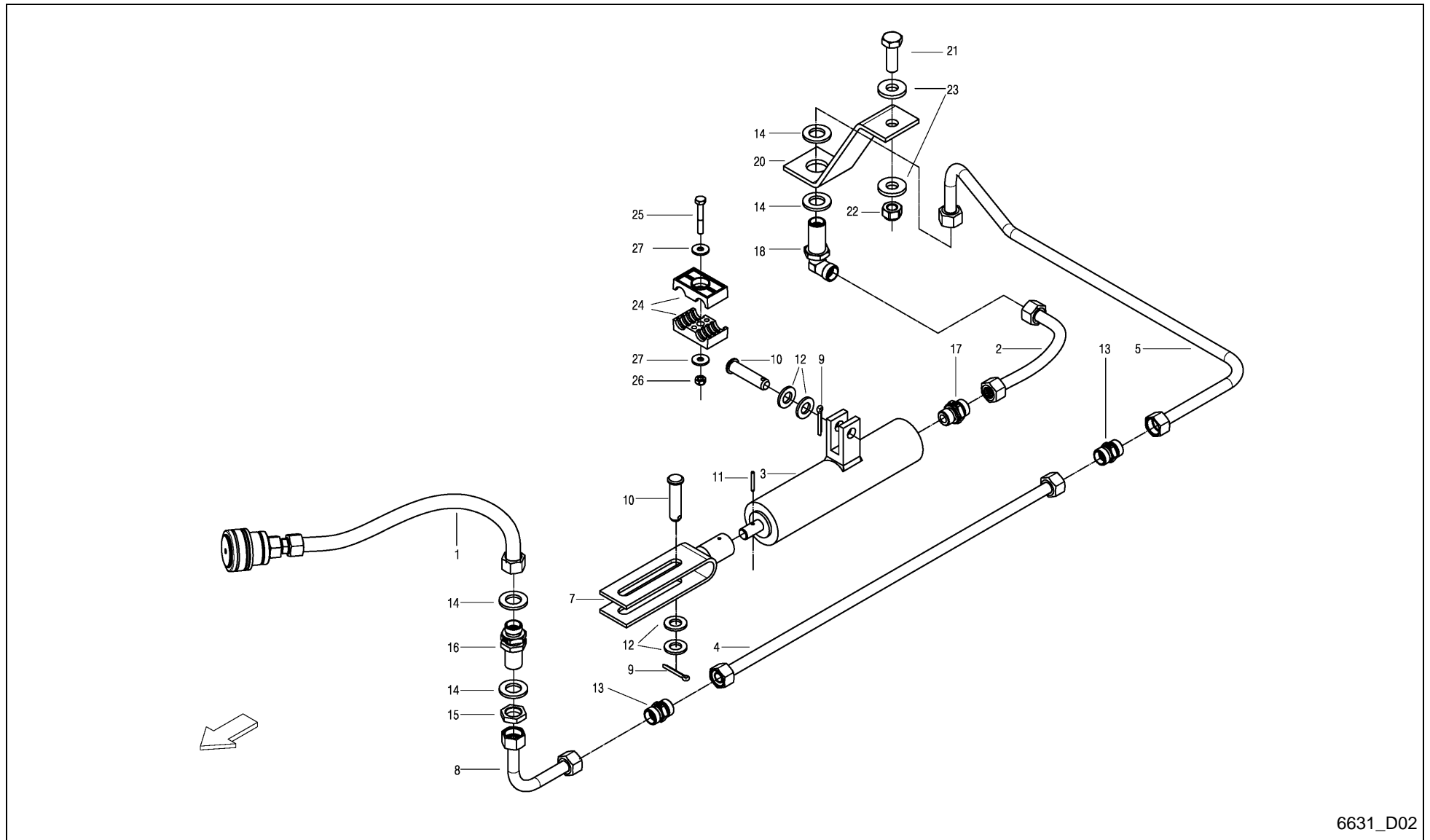

6631_D02

Feedex 360 T / HYDR. BRAKE SYSTEM FOR TANDEM AXLE 2-WHEELS BRAKED



PosNo.	Part No.	Qty.	Description	Remark
1	VF16613255	1	HYDR.HOSE	
2	VF16613337	1	HYDR.HOSE	
3	VF06587659	1	HYDR. CYLINDER	
4	VF16516426	1	HYDR.PIPE	
5	VF16610922	1	HYDR.PIPE	
7	VF16513900	1	CLEVIS	
8	VF16610994	1	HYDR.PIPE	
9	VF01106451	2	SPLIT PIN	
10	VF06210017	2	BOLT DIN1434-12H11X50X44	
11	KG01184962	1	TENSION PIN 3X24	
12	VF06214207	4	WASHER	
13	VF01116708	2	CONNECTING SLEEVE	
14	VF01124633	4	WASHER	
15	VF06216908	2	WHEEL NUT M 18X1,5 DIN80705	
16	VF01100600	1	STRAIGHT CONNECTOR XSV 12-L CF	
17	VF16611308	1	SOCKET XGE 12L-R3/8" CF	
18	VF01101288	1	BULKHEAD ELBOW XWSV 12L CF	
20	VF16513869	1	RETAINER	
21	VF01103341	1	HEX.HEAD SCREW	
22	VF06209769	1	LOCK NUT	
23	VF06214206	3	WASHER 13X30X4 RM=580-680 MPA A2C	
24	VF06578035	2	CLAMP	
25	VF01111071	1	HEX. HEAD SCREW	
26	VF01114357	1	LOCK NUT	
27	VF06214189	4	WASHER 6,4X18X2 A2C	

Feedex 360 T / HYDR. BRAKE SYSTEM FOR TANDEM AXLE 4-WHEELS BRAKED

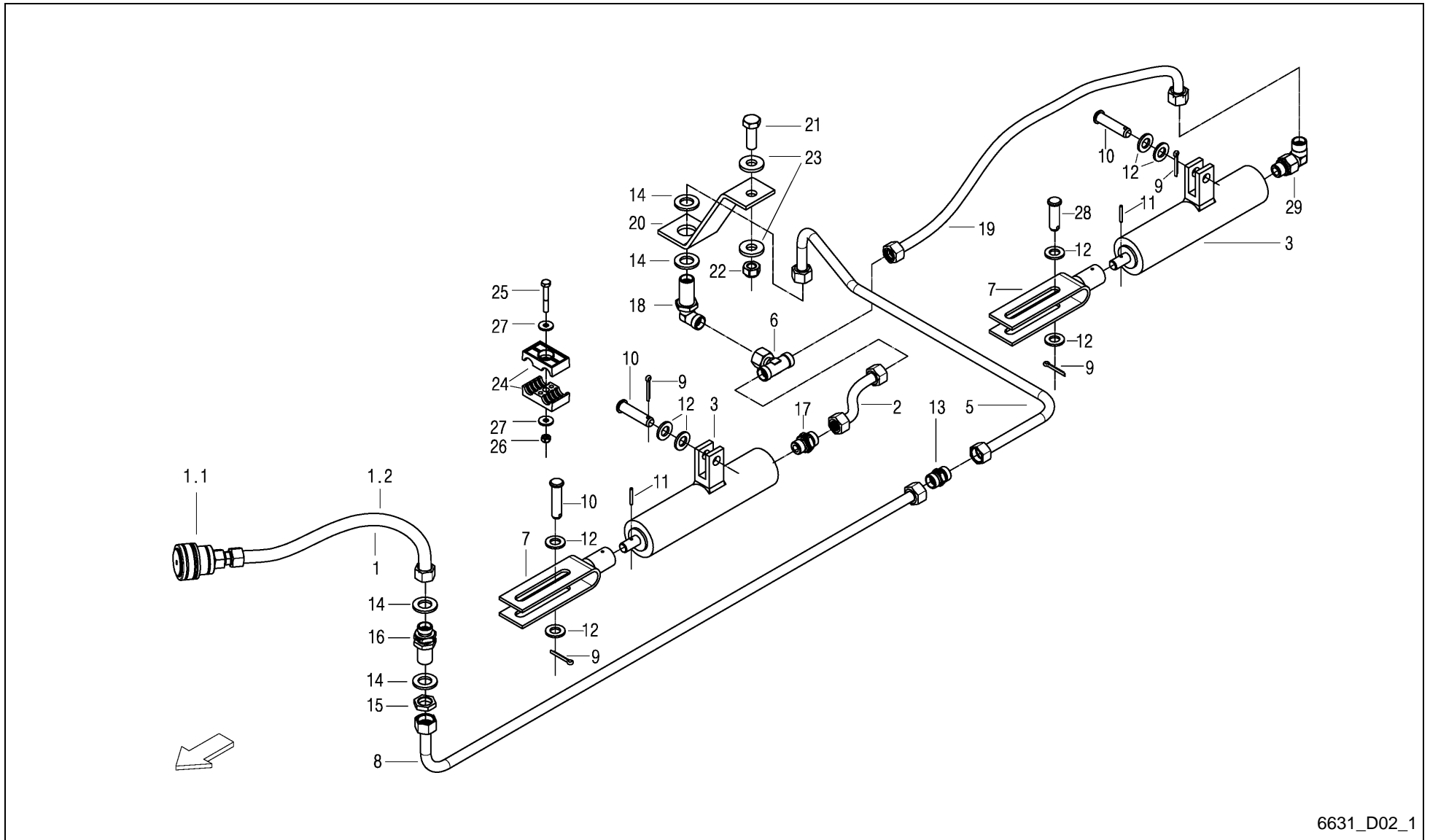

6631_D02_1

Feedex 360 T / HYDR. BRAKE SYSTEM FOR TANDEM AXLE 4-WHEELS BRAKED



PosNo.	Part No.	Qty.	Description	Remark
1	VF16613255	1	HYDR.HOSE	
1.1	VF16613256	1	HYDR.PIPE IG M 18X1,5 ISO 56	
1.2	VF06554678	1	HYDR. HOSE 0BODN10X2500 DKOL-12L	
2	VF16613337	1	HYDR.HOSE	
3	VF16518038	2	CYLINDER	
4	VF16516426	1	HYDR.PIPE	
5	VF16610922	1	HYDR.PIPE	
6	VF16631272	1	NOZZLE	
7	VF16513900	2	CLEVIS	
8	VF16610994	1	HYDR.PIPE	
9	VF01106451	4	SPLIT PIN	
10	VF06210017	3	BOLT DIN1434-12H11X50X44	
11	KG01184962	1	TENSION PIN 3X24	
12	VF06214207	8	WASHER	
13	VF01116708	2	CONNECTING SLEEVE	
14	VF01124633	4	WASHER	
15	VF06216908	2	WHEEL NUT M 18X1,5 DIN80705	
16	VF01100600	1	STRAIGHT CONNECTOR XSV 12-L CF	
17	VF16611308	1	SOCKET XGE 12L-R3/8" CF	
18	VF01101288	1	BULKHEAD ELBOW XWSV 12L CF	
19	VF16631271	1	HYDR. HOSE	
20	VF16513869	1	RETAINER	
21	VF01103341	1	HEX.HEAD SCREW	
22	VF06209769	1	LOCK NUT	
23	VF06214206	3	WASHER 13X30X4 RM=580-680 MPA A2C	
24	VF06578035	2	CLAMP	
25	VF01111071	1	HEX. HEAD SCREW	
26	VF01114357	1	LOCK NUT	
27	VF06214189	4	WASHER 6,4X18X2 A2C	
28	VF06210015	1	PIN	
29	VF16631273	1	ANGLE UNION	

Feedex 360 T / COMPRES.AIR SYSTEM SPRUNG TANDEM AXLE_SINGLE AXIS (-A 2017)

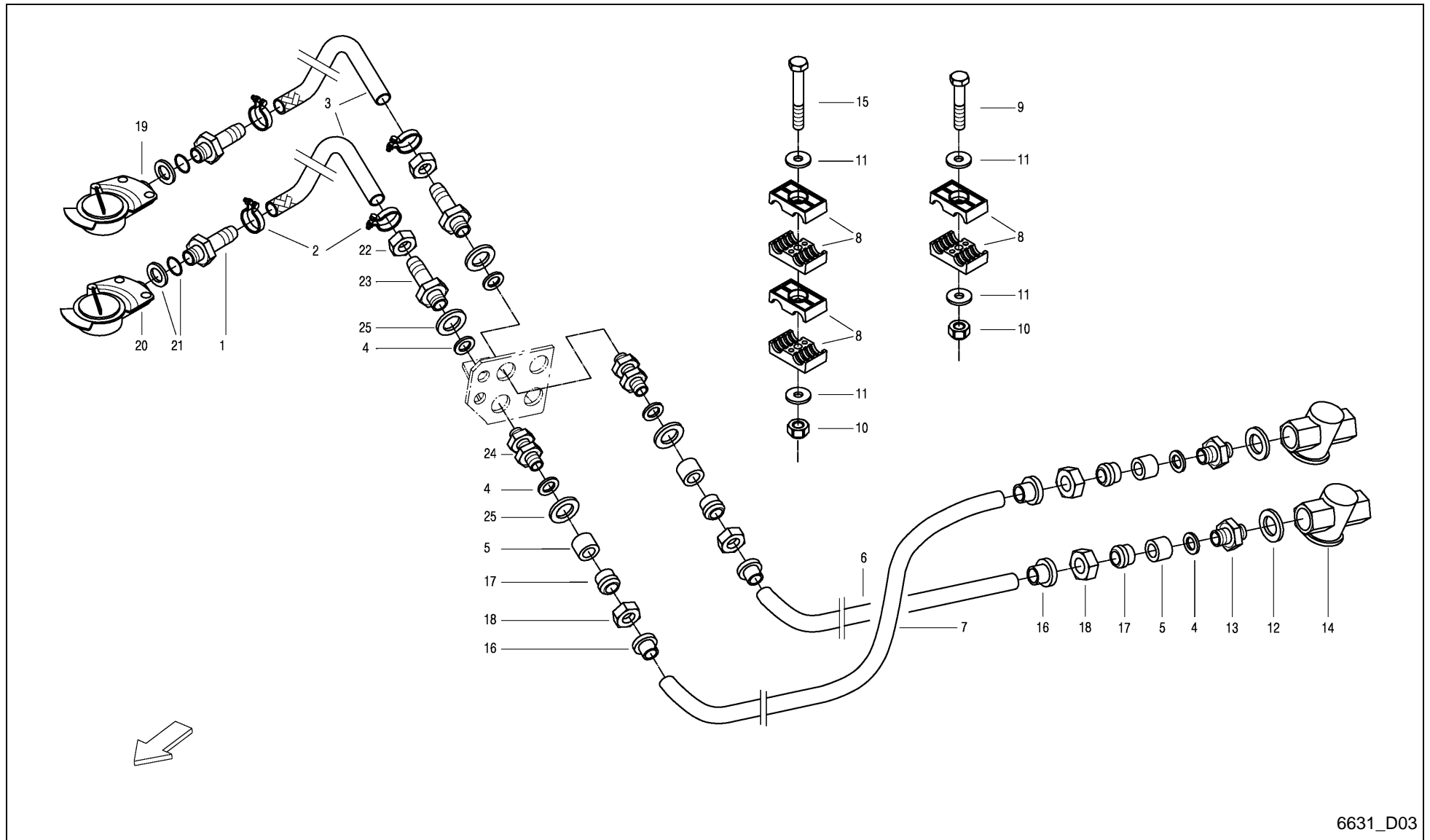

6631_D03

Feedex 360 T / COMPRES.AIR SYSTEM SPRUNG TANDEM AXLE_SINGLE AXIS (-A 2017)



PosNo.	Part No.	Qty.	Description	Remark
1	VF06216771	2	TUBE	
2	VF06216772	4	HOSE CLAMP WEDTH 15	
3	VF06558991	2	BRAKE TUBE	
4	VF06277296	6	SEAL RING A12X19X1,5 VF	
5	VF01125146	6	THRUST RING DIN3867-AL15	
6	VF16630506	1	PLASTIC TUBE	
7	VF16630507	1	PLASTIC TUBE	
8	VF06578035	6	CLAMP	
9	VF01122389	1	HEX.HEAD SCREW	
10	VF01114357	3	LOCK NUT	
11	VF06214189	3	WASHER 6,4X18X2 A2C	
12	VF01118736	2	SEAL RING A22X27DIN7603-AL	
13	VF01142247	2	NOZZLE XGEB16M22D13	
14	VF06558801	2	FILTER M22X1,5	
15	VF01126974	2	HEX. HEAD SCREW	
16	VF02953369	4	PLUG-IN SLEEVE	
17	VF01116626	4	CUTTING RING D15L DIN 3861 ST A3C	
18	VF01125152	4	UNION NUT L15 DIN3872	
19	VF16630646	1	COUPLING HEAD, YELLOW	
20	VF16630647	1	COUPLING HEAD, RED	
21	VF06216757	2	SEAL RING DRM22	
22	VF01142083	2	UNION NUT BLL15DIN3870	
23	VF01121766	2	TUBE DIN74304-A	
24	VF06216763	2	TWIN NOZZEL XGS15M22D99+SM	
25	VF06214307	4	WASHER	

Feedex 360 T / COMPRES.AIR SYSTEM SPRUNG TANDEM AXLE_SINGLE AXIS (+A 2018)

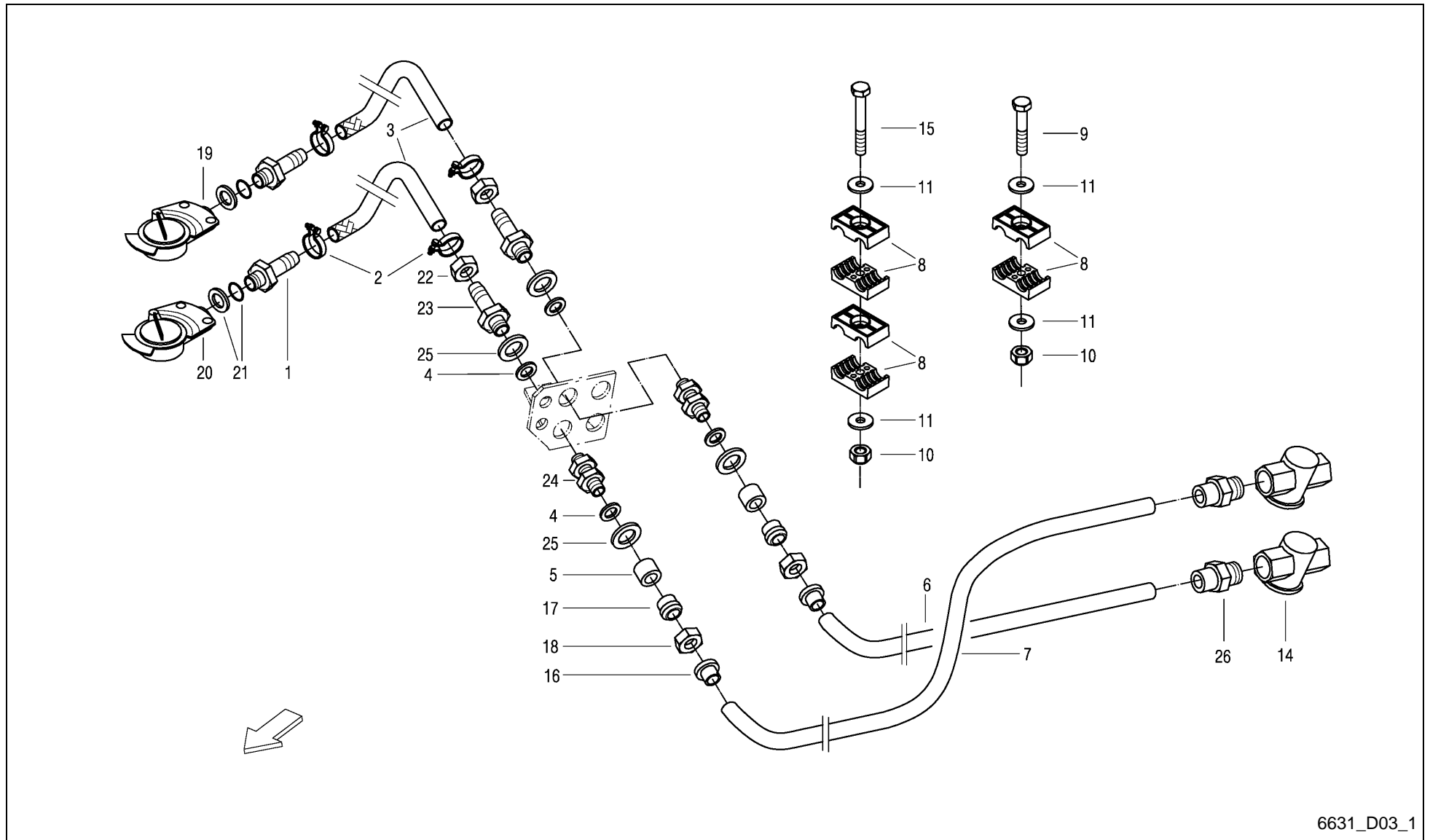

6631_D03_1

Feedex 360 T / COMPRES.AIR SYSTEM SPRUNG TANDEM AXLE_SINGLE AXIS (+A 2018)



PosNo.	Part No.	Qty.	Description	Remark
1	VF06216771	2	TUBE	
2	VF06216772	4	HOSE CLAMP WEDTH 15	
3	A143046200	2	BRAKE HOSE 2800 MM	
4	VF06277296	4	SEAL RING A12X19X1,5 VF	
5	VF01125146	2	THRUST RING DIN3867-AL15	
6	VF16630506	1	PLASTIC TUBE	
7	VF16630507	1	PLASTIC TUBE	
8	VF06578035	6	CLAMP	
9	VF01122389	1	HEX.HEAD SCREW	
10	VF01114357	3	LOCK NUT	
11	VF06214189	3	WASHER 6,4X18X2 A2C	
14	VF06558801	2	FILTER M22X1,5	
15	VF01126974	2	HEX. HEAD SCREW	
16	VF02953369	2	PLUG-IN SLEEVE	
17	VF01116626	2	CUTTING RING D15L DIN 3861 ST A3C	
18	VF01125152	2	UNION NUT L15 DIN3872	
19	VF16630646	1	COUPLING HEAD, YELLOW	
20	VF16630647	1	COUPLING HEAD, RED	
21	VF06216757	2	SEAL RING DRM22	
22	VF01142083	2	UNION NUT BLL15DIN3870	
23	VF01121766	2	TUBE DIN74304-A	
24	VF06216763	2	TWIN NOZZEL XGS15M22D99+SM	
25	VF06214307	4	WASHER	
26	A143043000	2	STRAIGHT SCREW-IN CONNECTOR	

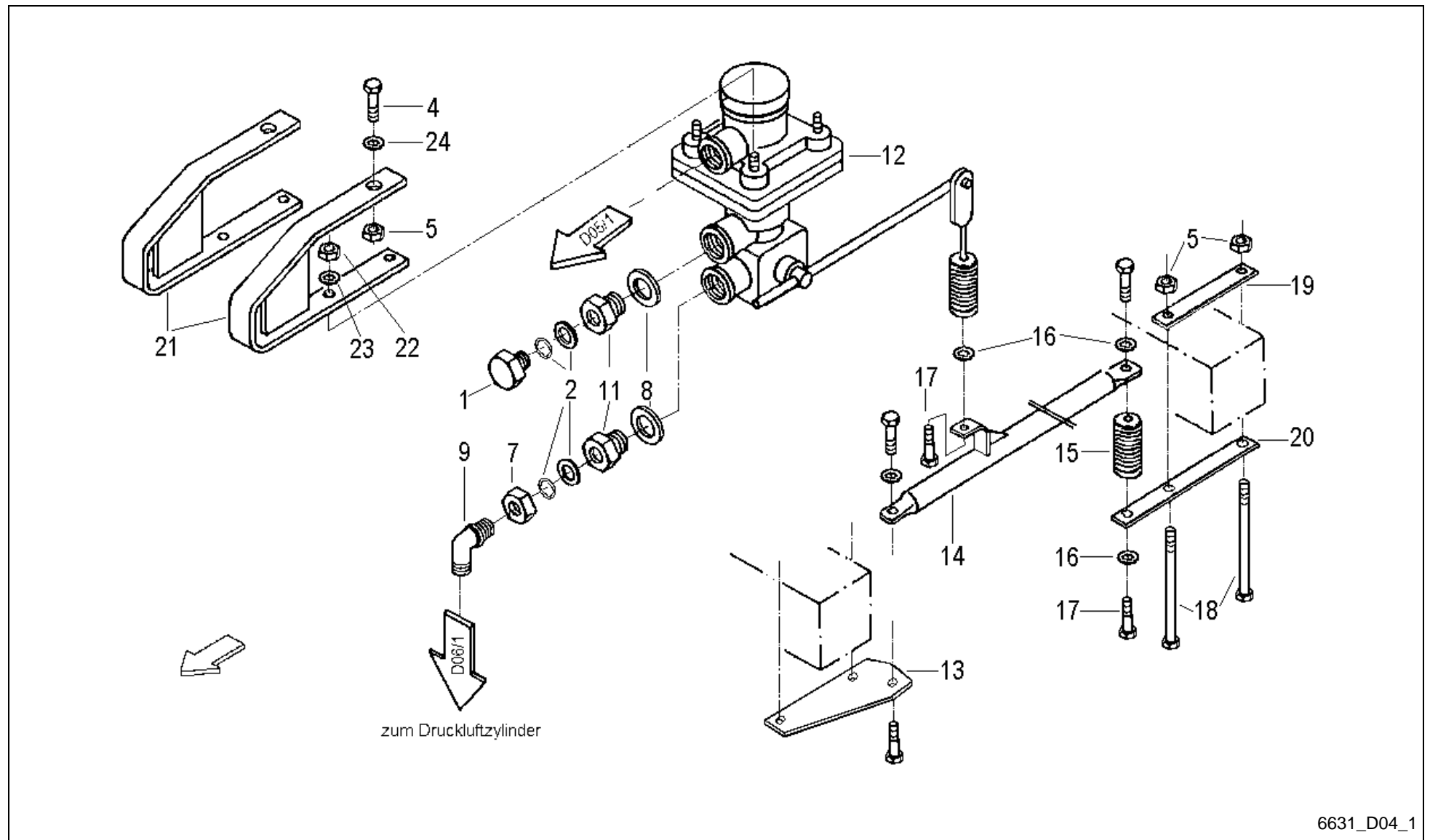

Feedex 360 T / PRESS.AIR BRAKE WITH AUTOM.LOAD-SENSING VALVE (+A 2018)



PosNo.	Part No.	Qty.	Description	Remark
1	VF06216756	1	BANJO BOLT HS15D05	
2	VF06216757	2	SEAL RING DRM22	
4	VF01112439	2	HEX. HEAD SCREW	
5	VF06209768	4	LOCK NUT	
7	VF01137633	1	WHEEL NUT M22 X 1,5 DIN80705 A2C	
8	VF01118699	2	SEALING WASHER	
9	VF01142246	1	ELBOW M22 (HALDEX 032018509)	
11	VF02953368	2	REDUCING SOCKET	
12	VF16615010	1	LOAD-SENSING VALVE	
13	VF16630231	1	CONNECTING PLATE	
14	VF16614984	1	CONNECTING PIPE	
15	VF16615012	2	SPRING STOP	
16	VF01102800	5	SPRING WASHER	
17	VF01112418	5	BOLT, SCREW	
18	VF01111352	2	HEX.HEAD SCREW	
19	VF16615013	1	RETAINER	
20	VF16615014	1	RETAINER	
21	VF16614995	2	RETAINER	
22	VF01104944	4	NY LOCK NUT 8A3CD985	
23	VF01107163	4	WASHER	
24	VF01107165	2	WASHER M10 11X20X2 A2C DIN126	

Feedex 360 T / PRESS.AIR BRAKE WITH AUTOM.LOAD-SENSING VALVE (-A 2017)

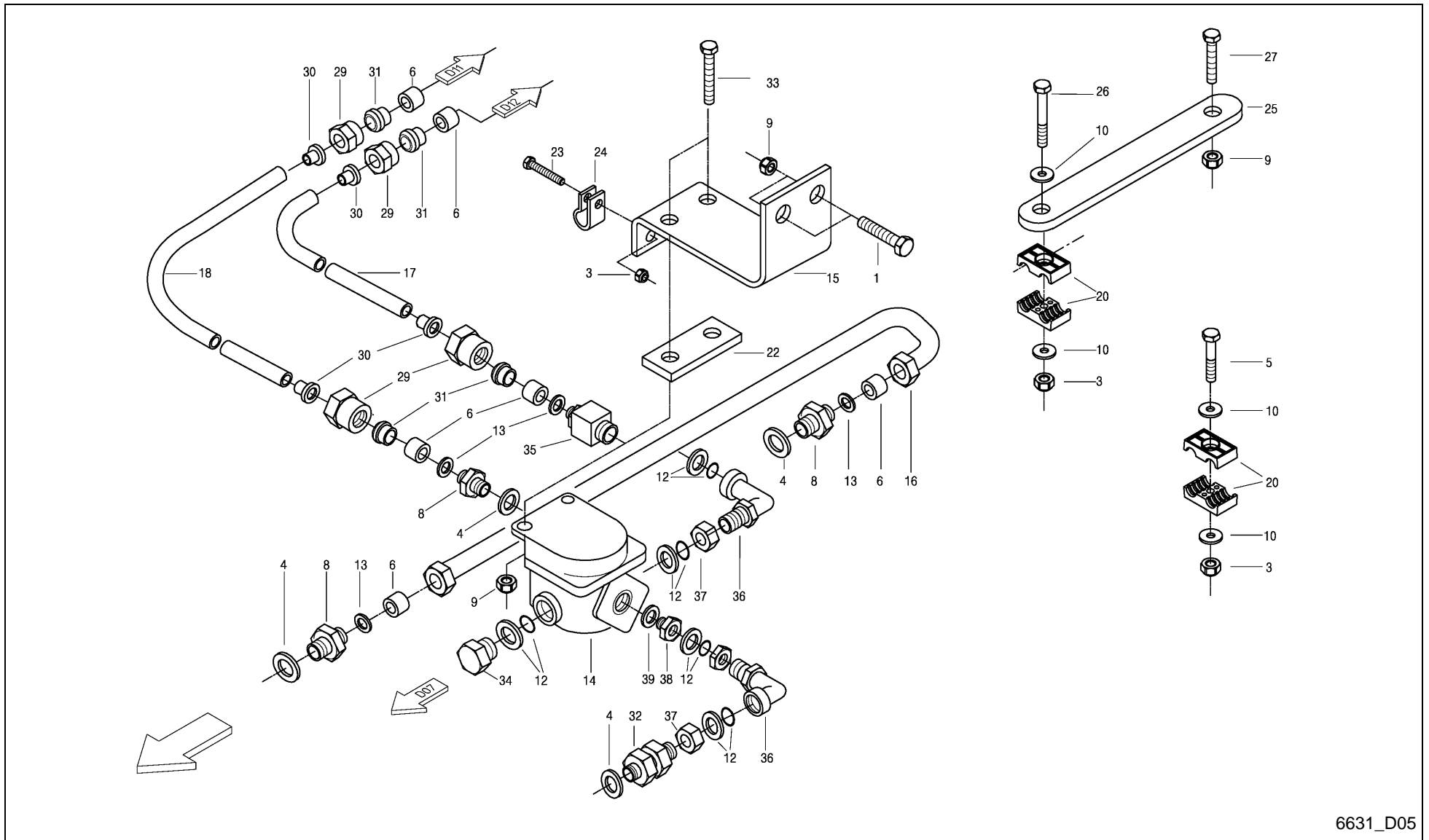

6631_D05

Feedex 360 T / PRESS.AIR BRAKE WITH AUTOM.LOAD-SENSING VALVE (-A 2017)



PosNo.	Part No.	Qty.	Description	Remark
1	VF01112429	2	HEX. HEAD SCREW	
3	VF01114357	3	LOCK NUT	
4	VF01118736	4	SEAL RING A22X27DIN7603-AL	
5	VF01122389	2	HEX.HEAD SCREW	
6	VF01125146	6	THRUST RING DIN3867-AL15	
8	VF01142247	3	NOZZLE XGEB16M22D13	
9	VF06209768	4	LOCK NUT	
10	VF06214189	4	WASHER 6,4X18X2 A2C	
12	VF06216757	5	SEAL RING DRM22	
13	VF06277296	6	SEAL RING A12X19X1,5 VF	
14	VF16519102	1	BRAKE VALVE	
15	VF16630254	1	BRACKET	+A 2000
16	VF16518934	1	BRAKE TUBE	
17	VF16519107	1	PLASTIC TUBE	
18	VF16519106	1	PLASTIC TUBE	
20	VF06578035	3	CLAMP	
22	VF16518084	1	SHIM	
23	VF01103316	1	HEX. HEAD SCREW	
24	VF01211882	1	PIPE CLIP RSGU1 15X15	
25	VF16518926	1	RETAINER	
26	VF01102664	1	HEX HEAD SCREW	
27	VF01112439	1	HEX. HEAD SCREW	
29	VF01125152	4	UNION NUT L15 DIN3872	
30	VF02953369	4	PLUG-IN SLEEVE	
31	VF01116626	4	CUTTING RING D15L DIN 3861 ST A3C	
32	VF06216763	1	TWIN NOZZEL XGS15M22D99+SM	
33	VF01112447	2	HEX.HEAD SCREW	
34	VF06216756	1	BANJO BOLT HS15D05	
35	VF06216762	1	STRAIGHT UNION	
36	VF16615011	2	ANGLE PIECE	
37	VF01137633	3	WHEEL NUT M22 X 1,5 DIN80705 A2C	
38	VF02953368	1	REDUCING SOCKET	
39	VF01118699	1	SEALING WASHER	

Feedex 360 T / PRESS.AIR BRAKE WITH AUTOM.LOAD-SENSING VALVE (+A 2018)

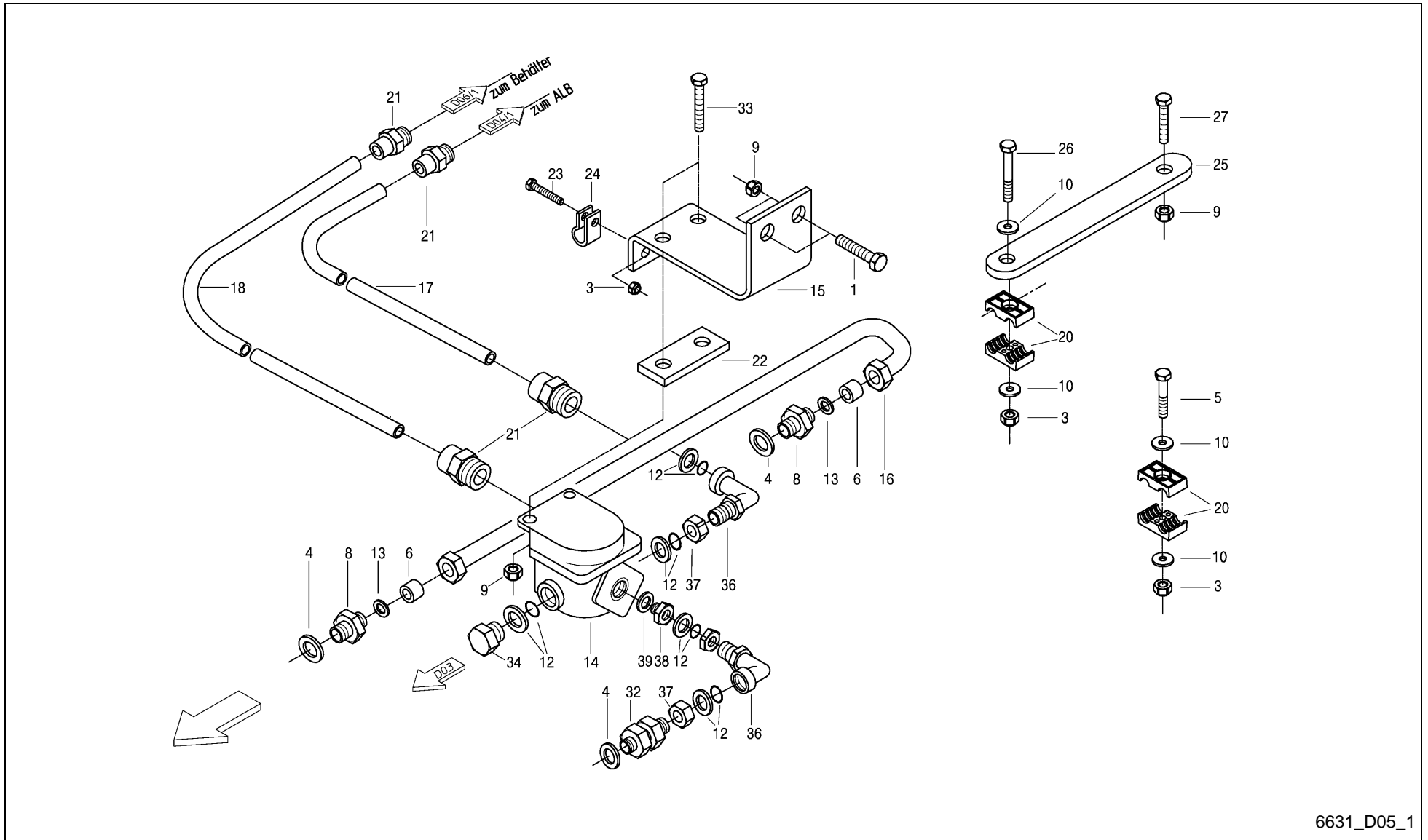

6631_D05_1

Feedex 360 T / PRESS.AIR BRAKE WITH AUTOM.LOAD-SENSING VALVE (+A 2018)



PosNo.	Part No.	Qty.	Description	Remark
1	VF01112429	2	HEX. HEAD SCREW	
3	VF01114357	3	LOCK NUT	
4	VF01118736	3	SEAL RING A22X27DIN7603-AL	
5	VF01122389	2	HEX.HEAD SCREW	
6	VF01125146	2	THRUST RING DIN3867-AL15	
8	VF01142247	2	NOZZLE XGEB16M22D13	
9	VF06209768	4	LOCK NUT	
10	VF06214189	4	WASHER 6,4X18X2 A2C	
12	VF06216757	5	SEAL RING DRM22	
13	VF06277296	2	SEAL RING A12X19X1,5 VF	
14	VF16519102	1	BRAKE VALVE	
15	A143043186	1	ANGLE	
16	VF16518934	1	BRAKE TUBE	
17	VF16519107	1	PLASTIC TUBE	
18	VF16519106	1	PLASTIC TUBE	
20	VF06578035	3	CLAMP	
21	A143043000	4	STRAIGHT SCREW-IN CONNECTOR	
22	VF16518084	1	SHIM	
23	VF01103316	1	HEX. HEAD SCREW	
24	VF01211882	1	PIPE CLIP RSGU1 15X15	
25	VF16518926	1	RETAINER	
26	VF01102664	1	HEX HEAD SCREW	
27	VF01112439	1	HEX. HEAD SCREW	
32	VF06216763	1	TWIN NOZZEL XGS15M22D99+SM	
33	VF01112447	2	HEX.HEAD SCREW	
34	VF06216756	1	BANJO BOLT HS15D05	
36	VF16615011	2	ANGLE PIECE	
37	VF01137633	3	WHEEL NUT M22 X 1,5 DIN80705 A2C	
38	VF02953368	1	REDUCING SOCKET	
39	VF01118699	1	SEALING WASHER	

Feedex 360 T / COMPRESSED AIR SYSTEM TANDEM AXLE SPRING BORN (-A 2017)

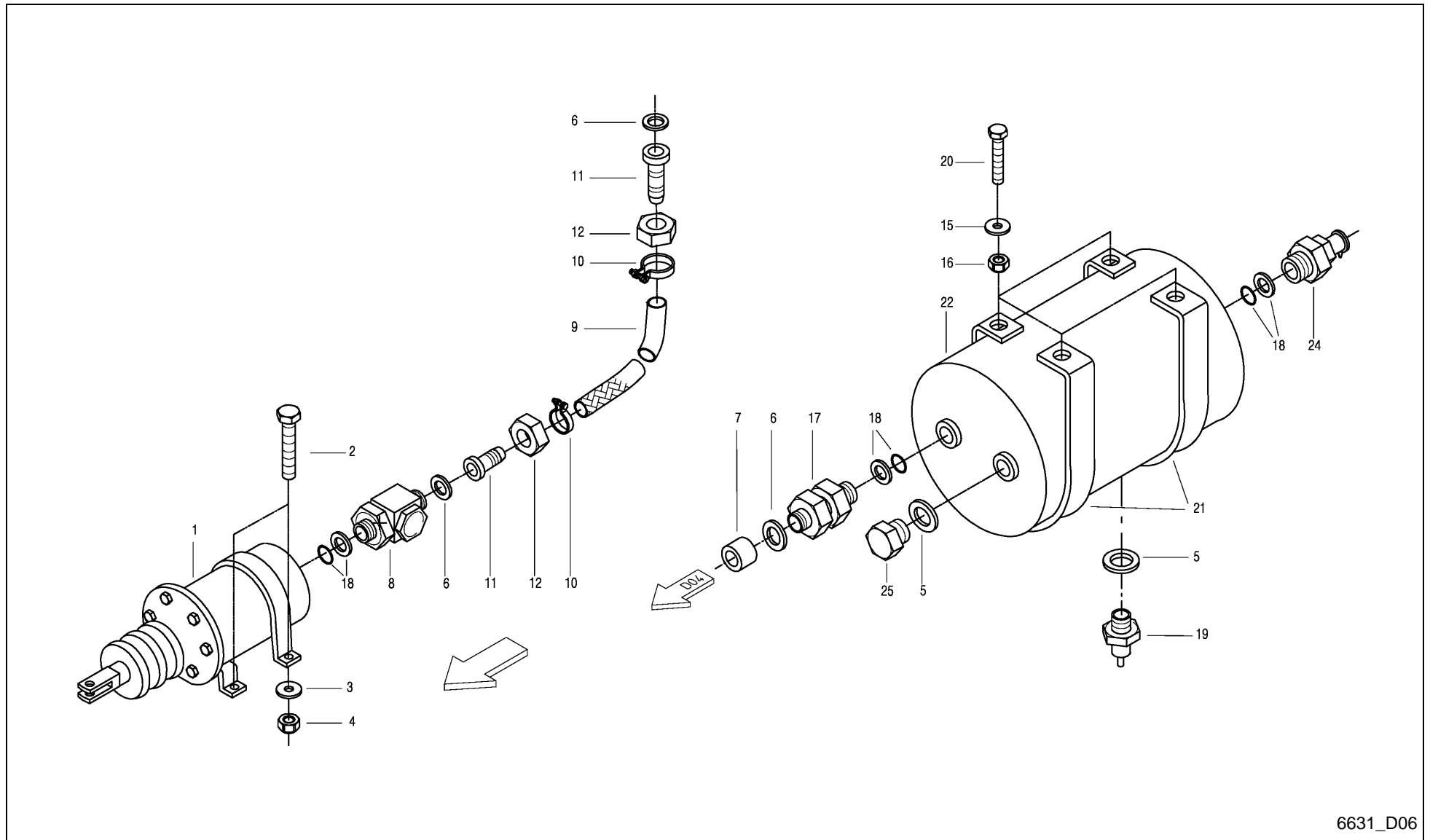

6631_D06

Feedex 360 T / COMPRESSED AIR SYSTEM TANDEM AXLE SPRING BORN (-A 2017)



PosNo.	Part No.	Qty.	Description	Remark
1	VF16513522	1	AIR CYLINDER	
2	VF01103341	4	HEX.HEAD SCREW	
3	VF06214206	4	WASHER 13X30X4 RM=580-680 MPA A2C	
4	VF06209778	4	LOCK NUT	
5	VF01118736	2	SEAL RING A22X27DIN7603-AL	
6	VF06277296	3	SEAL RING A12X19X1,5 VF	
7	VF01125146	3	THRUST RING DIN3867-AL15	
8	VF06216762	1	STRAIGHT UNION	
9	VF06558992	1	BRAKE TUBE	
10	VF06216772	2	HOSE CLAMP WEDTH 15	
11	VF01121766	1	TUBE DIN74304-A	
12	VF01142083	1	UNION NUT BLL15DIN3870	
15	VF06214197	6	WASHER 10,5X30X3 GALV.	
16	VF06209768	4	LOCK NUT	
17	VF06216763	1	TWIN NOZZEL XGS15M22D99+SM	
18	VF06216757	5	SEAL RING DRM22	
19	VF06216747	1	BLEED VALVE EV-C15D92 M.R.	
20	VF01112439	4	HEX. HEAD SCREW	
21	VF16513677	2	CLAMPING YOKE	
22	VF06216745	1	AIR TANK	
24	VF01142023	1	BANJO BOLT WITH TEST CONNECTION	
25	VF06216756	1	BANJO BOLT HS15D05	

Feedex 360 T / COMPRESSED AIR SYSTEM TANDEM AXLE SPRING BORN (+A 2018)

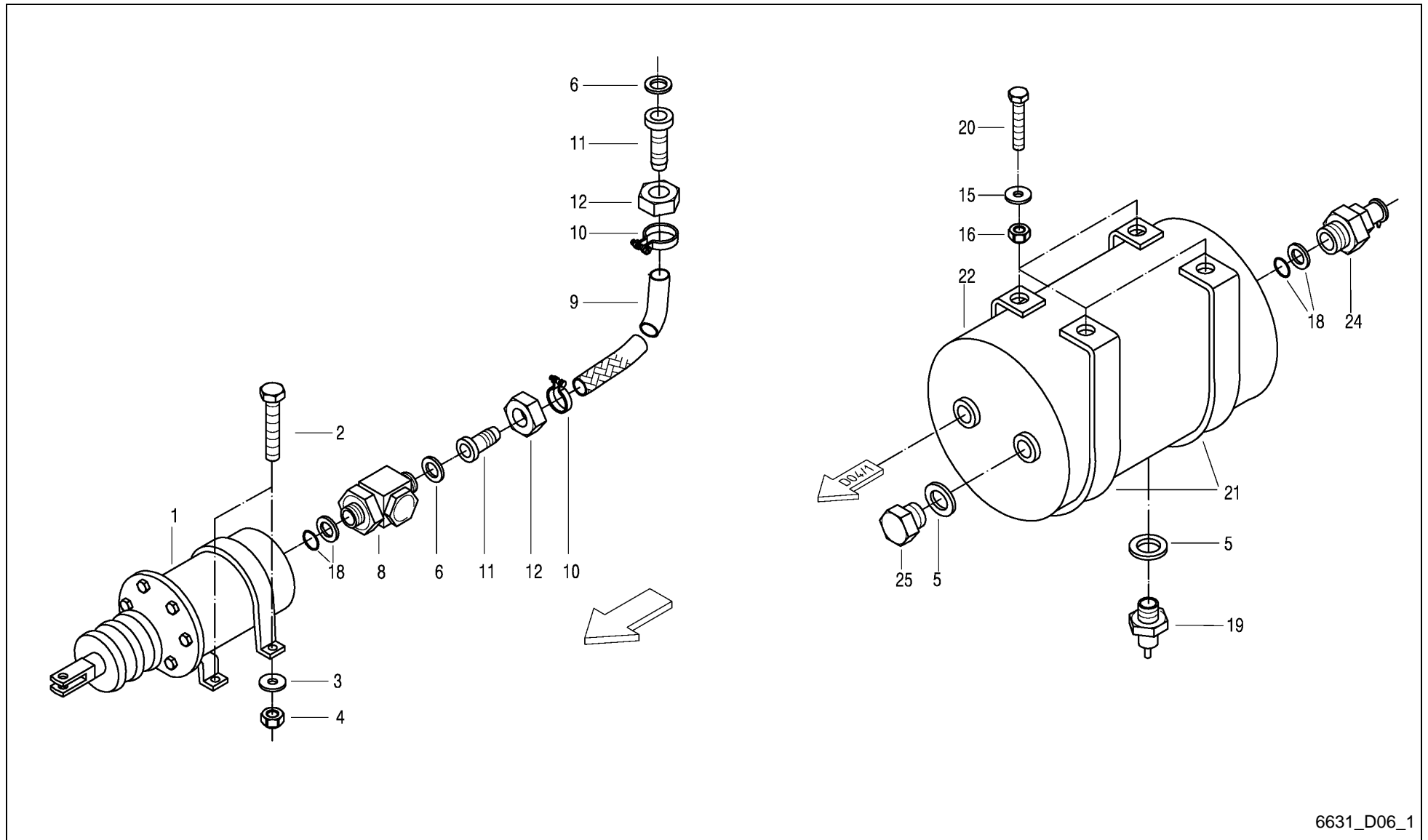

6631_D06_1

Feedex 360 T / COMPRESSED AIR SYSTEM TANDEM AXLE SPRING BORN (+A 2018)



PosNo.	Part No.	Qty.	Description	Remark
1	VF16513522	1	AIR CYLINDER	
2	VF01112538	4	HEX.HEAD SCREW	
3	VF06214206	4	WASHER 13X30X4 RM=580-680 MPA A2C	
4	VF06209778	4	LOCK NUT	
5	VF01118736	2	SEAL RING A22X27DIN7603-AL	
6	VF06277296	2	SEAL RING A12X19X1,5 VF	
7	VF01125146	2	THRUST RING DIN3867-AL15	
8	VF06216762	1	STRAIGHT UNION	
9	VF06558992	1	BRAKE TUBE	
10	VF06216772	2	HOSE CLAMP WEDTH 15	
11	VF01121766	1	TUBE DIN74304-A	
12	VF01142083	1	UNION NUT BLL15DIN3870	
15	VF06214197	6	WASHER 10,5X30X3 GALV.	
16	VF06209768	4	LOCK NUT	
18	VF06216757	4	SEAL RING DRM22	
19	VF06216747	1	BLEED VALVE EV-C15D92 M.R.	
20	VF01112439	4	HEX. HEAD SCREW	
21	VF16513677	2	CLAMPING YOKE	
22	VF06216745	1	AIR TANK	
24	VF01142023	1	BANJO BOLT WITH TEST CONNECTION	
25	VF06216756	1	BANJO BOLT HS15D05	

Feedex 360 T / HYDR.SCRAPER FLOOR+TAILGATE

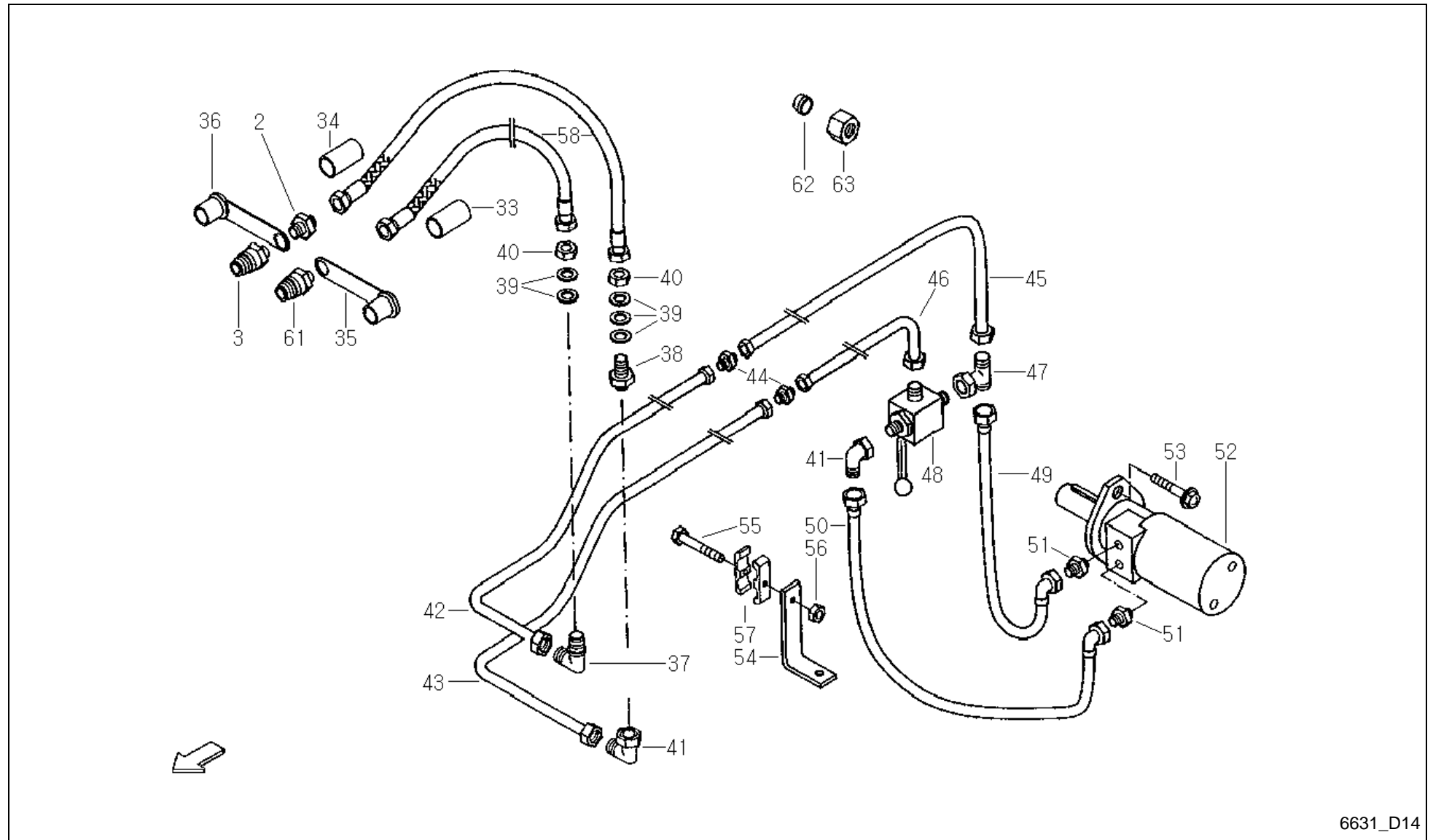

6631_D14

Feedex 360 T / HYDR.SCRAPER FLOOR+TAILGATE



PosNo.	Part No.	Qty.	Description	Remark
2	VF01397770	1	CHECK VALVE	
3	VF16613435	1	SAFETY PIN	
33	VF16515428	1	SHRINK TUBE RED 25X50	
34	VF16513948	1	SHRINK TUBE YELLOW 25X50	
35	VF01142006	1	DUST CAP	
36	VF06571341	1	DUST CAP BLACK 27MM DIAMETER	
37	VF01116758	1	TWO-WAY CONNECTOR	
38	VF01133922	1	NOZZLE AL15 D3910 GALV.	
39	VF06214306	5	WASHER 23X38X2 GALV. HV200	
40	VF01137633	2	WHEEL NUT M22 X 1,5 DIN80705 A2C	
41	VF16613433	2	ANGLE UNION	
42	VF16613439	1	HYDR,PIPE	
43	VF16613441	1	HYDR.PIPE	
44	VF01116710	2	CONNECTING SLEEVE	
45	VF16613443	1	HYDR.PIPE	
46	VF16613445	1	HYDR.PIPE	
47	VF16613434	1	T-CONNECTOR XET 15-L GALV.	
48	VF16613436	1	ROOSTER	
49	VF16613446	1	HYDR.HOSE	
50	VF16613447	1	HYDR.HOSE	
51	VF06216836	2	SOCKET XGE 15LR-ED CF	
52	VF16613240	1	HYDR. MOTOR MF160 VORM.	1663 0885 + 1661 3239
52.1	VF16630888		DICHTSATZ FÜR TORQMOTOR MOTOR MF 165	für Motor MF 165
52.2	VF16630889		DICHTSATZ FÜR HYDR.MOTOR EPM 160CD	für Hydraulikmotor EPM
52.3	VF16630900		SEALING KIT HYDR. ENGINE	für Hydraulikmotor EPRM
53	VF06214156	2	SCREW	
54	VF16613380	2	BRACKET	
55	VF01122389	6	HEX.HEAD SCREW	
56	VF01114357	6	LOCK NUT	
57	VF06578035	12	CLAMP	
58	VF16610873	2	HYDR.HOSE	
61	VF06571330	1	HOSE CONNECTION NW10, IG M 22X1,5	
62	VF01116626		CUTTING RING D15L DIN 3861 ST A3C	
63	VF01116653		UNION NUT H3105-CL15-ST- GALV.	

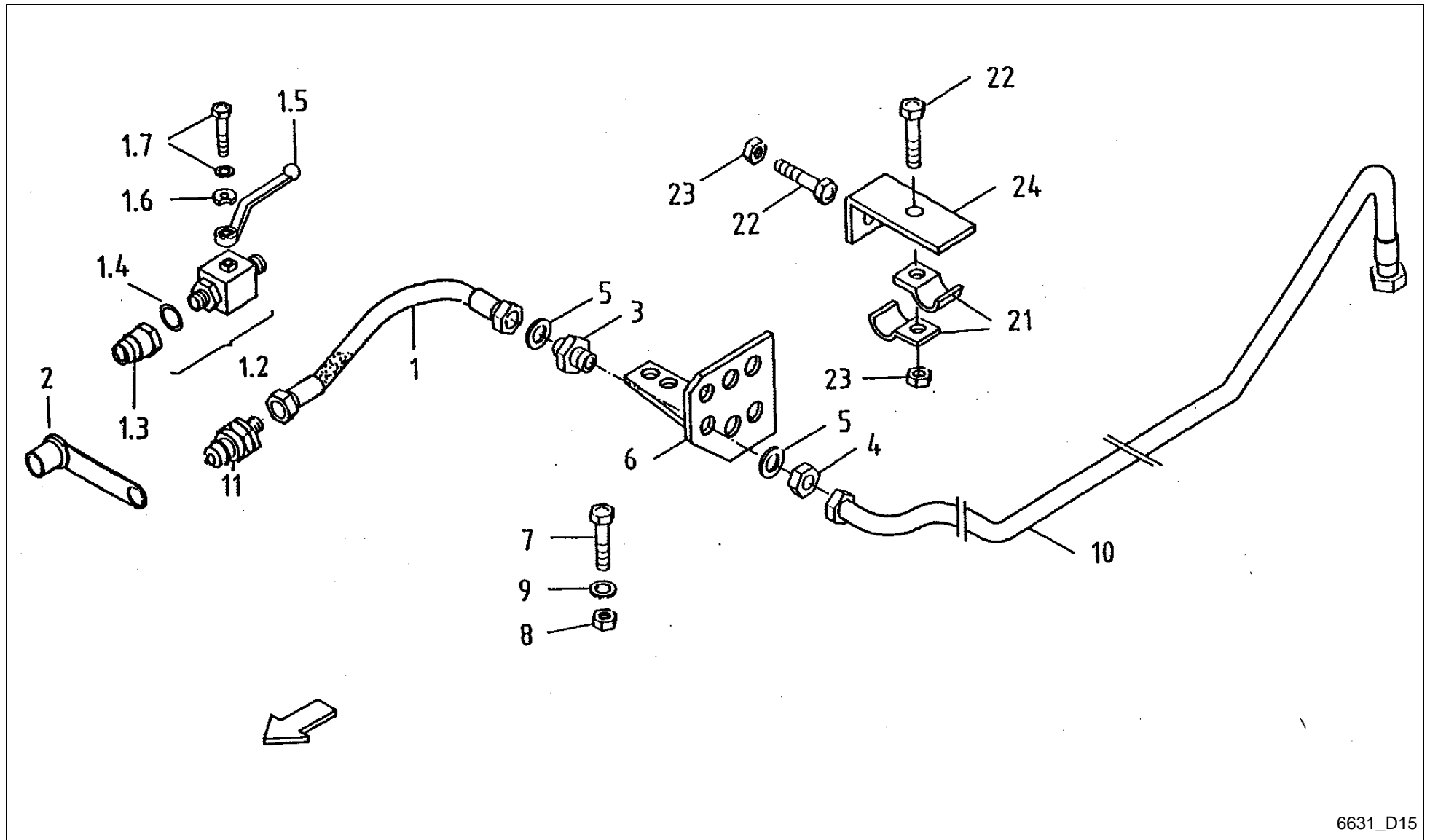

6631_D15



Feedex 360 T / HYDR. INSTALLATION BASIC CONTENT

PosNo.	Part No.	Qty.	Description	Remark
1	VF06582530	1	HYDR. HOSE 0BODN6X2500 DKOL-8L+DKOL-8L	
1	VF06582524	1	CLUTCH HOSE	-450
1.2	VF16604641	1	BALL VALVE W. CONNECTOR NW10	-450
1.3	VF16604726	1	SAFETY PIN FOR PISTE BALL VALVE 10L	-450
1.4	VF16604727	1	SEALING WASHER	-450
1.5	VF16604728	1	SHIFT LEVER	-450
1.6	VF16604729	1	SHIFT WASHER	-450
1.7	VF16604730	1	RIPP SCREW M 5X 8	-450
2	VF06571341	1	DUST CAP BLACK 27MM DIAMETER	
3	VF01123941	1	STRAIGHT CONNECTOR XSV 8-L CF	
4	VF01121824	1	NUT M14X1,5 GM08L CF	
5	VF06214202	2	WASHER 14X24X1,6 GALV.	
6	VF16518890	1	PLATE	
7	VF01112418	2	BOLT, SCREW	
8	VF06209768	2	LOCK NUT	
9	VF01107103	4	WASHER/DISC/PLATE	
10	VF16613449	1	HYDR.PIPE	S D21
11	VF16615171	1	PLUG CONTACT DN 10 EXTE. THREAD M 14X1,5	+451
21	VF06216397	2	FIXING CLIP	
22	VF01112264	2	HEX. HEAD SCREW	
23	VF01114357	2	LOCK NUT	
24	VF16613364	1	BRACKET	

Feedex 360 T / HYDR. FOR REAR GATE

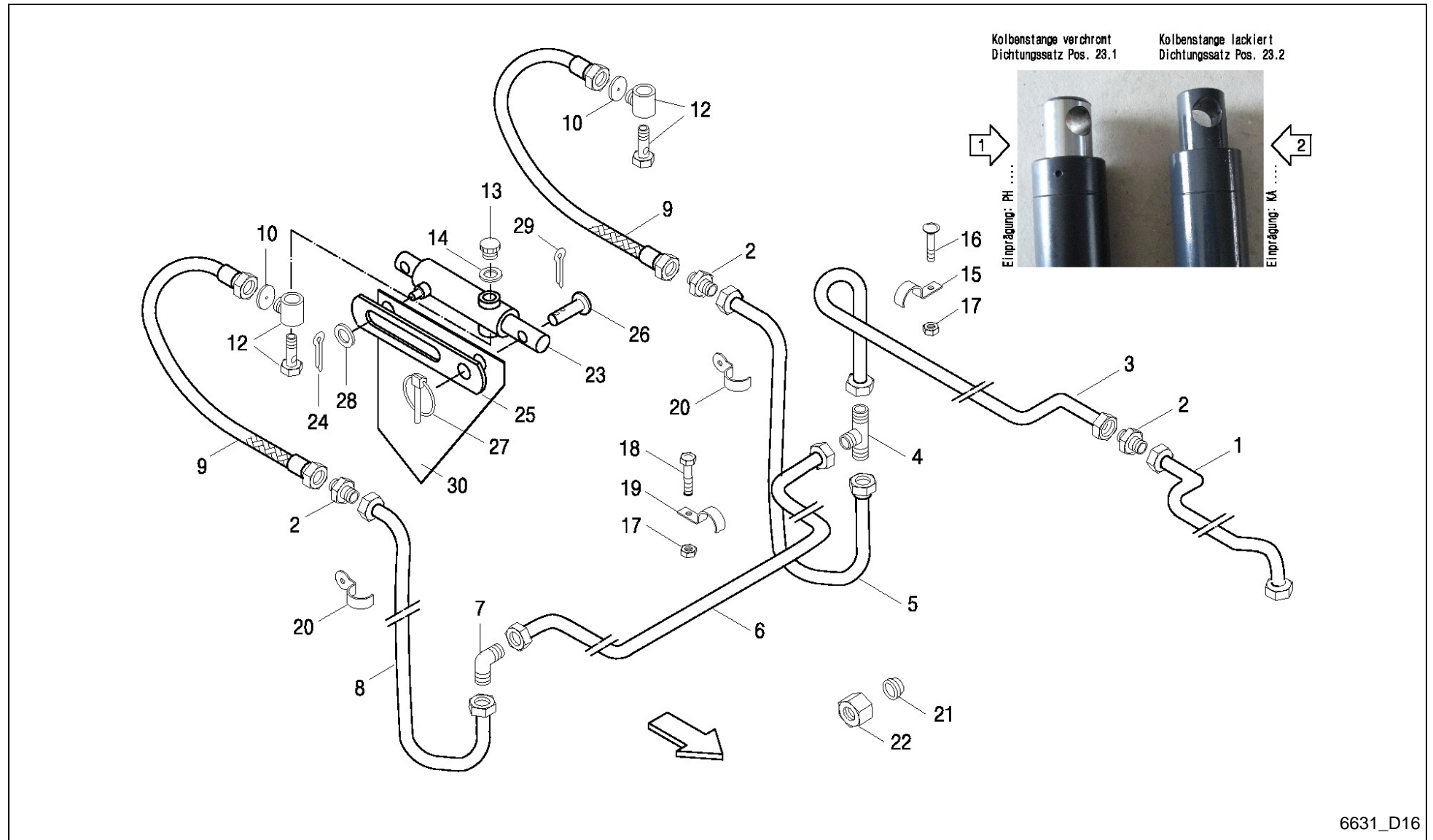



Feedex 360 T / HYDR. FOR REAR GATE

PosNo.	Part No.	Qty.	Description	Remark
1	VF16613313	1	HYDR.PIPE	
2	VF01116705	2	CONNECTING SLEEVE XG 8-L CF	
3	VF16613315	1	HYDR. PIPE	
4	VF01116740	1	NOZZLE XT 8-L GALV.	
5	VF16613319	1	HYDR.PIPE	
6	VF16613317	1	HYDR.PIPE	
7	VF01116731	1	SOCKET D3905 L 8 W08LCFX	
8	VF16613321	1	HYDR.PIPE	
9	VF16613311	2	HYDR.HOSE	
10	VF06577567	2	WASHER	
12	VF16631123	2	UNION 2 PIECE	
13	VF01143104	2	SCREW PLUG	
14	VF16611312	2	SEALING RING	
15	VF06216397	6	FIXING CLIP	
16	VF01142077	6	SAUCER HEAD SCREW	
17	VF01114357	9	LOCK NUT	
18	VF01123749	3	HEX. HEAD SCREW	
19	VF06258500	3	PIPE CLIP	
20	VF06216396	4	HOSE CLIP	
21	VF01116622		CUTTING RING D08L DIN 3861-ST	
22	VF01127346		UNION NUT H3105-CL 8-ST A3C	
23	VF16630658	2	HYDR. CYLINDER 30X300	E 16515933
23.1	VF16630657		SEALING SET	E 16516843
23.2	A143501400		SEAL KIT	
24	VF01122072	2	SPLIT PIN	
25	VF16515976	2	LIFT LIMIT	
26	VF16515987	2	PIN/BOLT/STUD	
27	VF16611321	2	LYNCH PIN 4X27 DIN1 1023 GALV.	
28	VF01107121	2	WASHER	
29	VF01106451	2	SPLIT PIN	
30	VF16611382	2	GUARD PLATE	

Feedex 360 T / HYDR. FOR PICK-UP

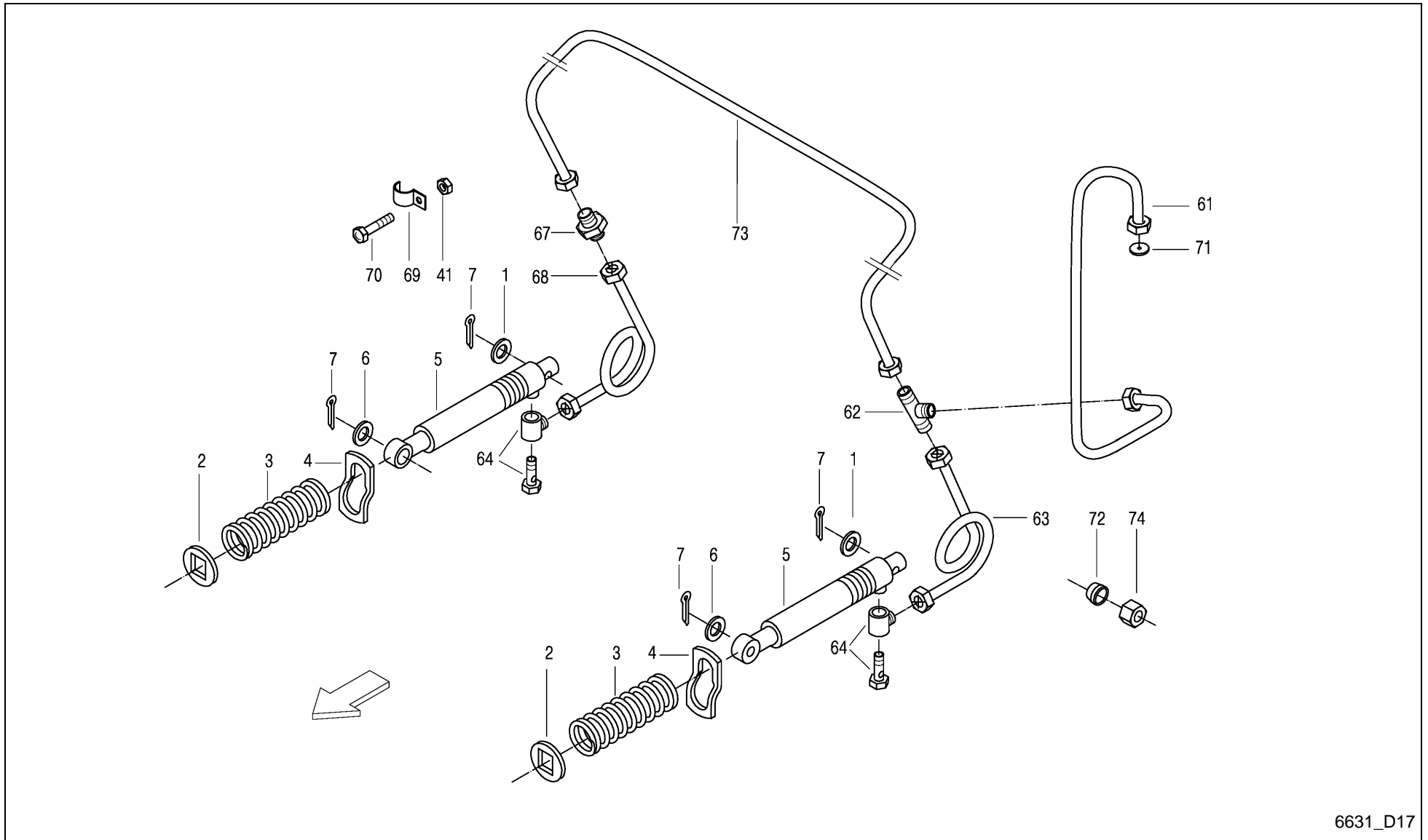

6631_D17



Feedex 360 T / HYDR. FOR PICK-UP

PosNo.	Part No.	Qty.	Description	Remark
1	KG01273861	2	WASHER DIN7349 M14 A3C	
2	VF16519184	2	WASHER/DISC/PLATE	
3	VF06215425	2	COMPRESSION SPRING	
4	VF06576503	2	CLIP	
5	VF16514629	2	CYLINDER, HYDR.	
5	VF16504079		SEALING SET	
6	VF06214585	2	WASHER	
7	VF01106451	4	SPLIT PIN	
41	VF01114357	6	LOCK NUT	
61	VF16517194	1	HYDR.PIPE	S D21
62	VF01116740	1	NOZZLE XT 8-L GALV.	
63	VF06577864	1	HYDR.PIPE	
64	VF16631123	2	UNION 2 PIECE	
68	VF16613306	1	HYDR.HOSE	
69	VF06216397	6	FIXING CLIP	
70	VF01112264	6	HEX. HEAD SCREW	
71	VF06581181	1	RESTRICTOR 1,0 MM D8,0X1	
72	VF01116622		CUTTING RING D08L DIN 3861-ST	
73	VF16613325	1	HYDR.HOSE	
74	VF01127346		UNION NUT H3105-CL 8-ST A3C	

Feedex 360 T / HYDR. FOR DRY FORAGE SUPERST.

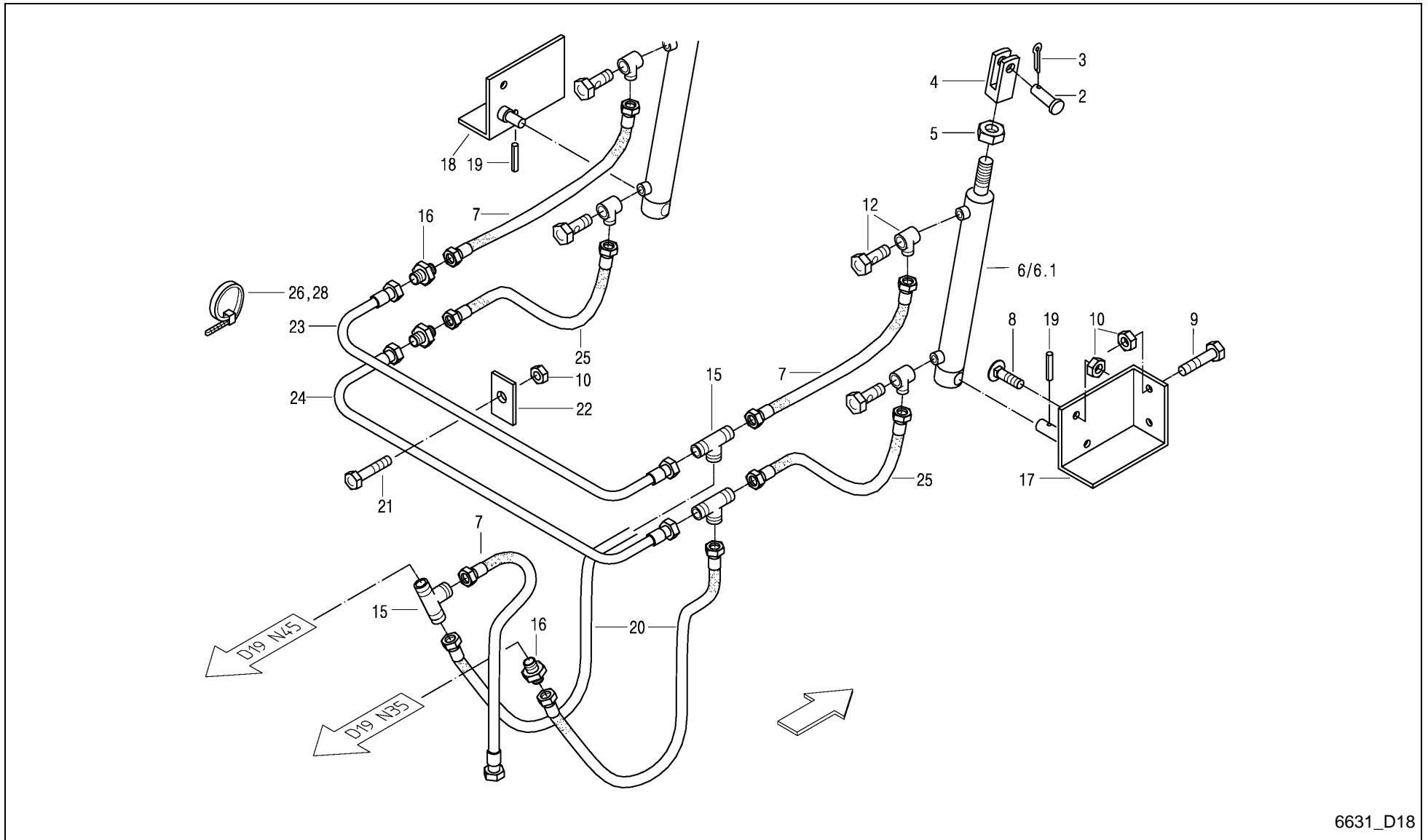

6631_D18

Feedex 360 T / HYDR. FOR DRY FORAGE SUPERST.



PosNo.	Part No.	Qty.	Description	Remark
1	VF01116622		CUTTING RING D08L DIN 3861-ST	
2	VF06210014	2	PIN	
3	VF01106447	2	SPLIT PIN	
4	VF06578611	2	CLEVIS	
5	VF01131116	2	HEX.NUT	
6	VF06577987	2	LIFT CYLINDER	
6	VF16512812	1	SEALING SET	
7	VF16613246	3	HYDR. HOSE 6X670	S D21
8	VF01141006	4	TRUSS-HEAD SCR. M8X16 109 GALV.	
9	VF01112322	4	HEX. HEAD SCREW	
10	VF01104944	11	NY LOCK NUT 8A3CD985	
12	VF16631123	4	UNION 2 PIECE	
14	VF01127346		UNION NUT H3105-CL 8-ST A3C	
15	VF01116740	3	NOZZLE XT 8-L GALV.	
16	VF01116705	3	CONNECTING SLEEVE XG 8-L CF	
17	VF06578608	1	BRACKET/CONSOLE	
18	VF06578609	1	BRACKET/CONSOLE	
19	VF01157344	2	DOWEL PIN	
20	VF16610781	2	HYDR.HOSE	
21	VF01100233	3	HEX.BOLT	
22	VF06555222	3	CONNECTING PLATE	
23	VF06578650	1	HYDR.PIPE	
24	VF06578651	1	HYDR.PIPE	
25	VF06576507	2	HYDR.HOSE	
26	VF06216480	2	CABLE TIE 368X4,8 SW SNX 3-100	
28	VF06216479	9	CABLE TIE 150X3,6 SW SNX 2-35	

Feedex 360 T / HYDR. FOR DRY FORAGE SUPERST.

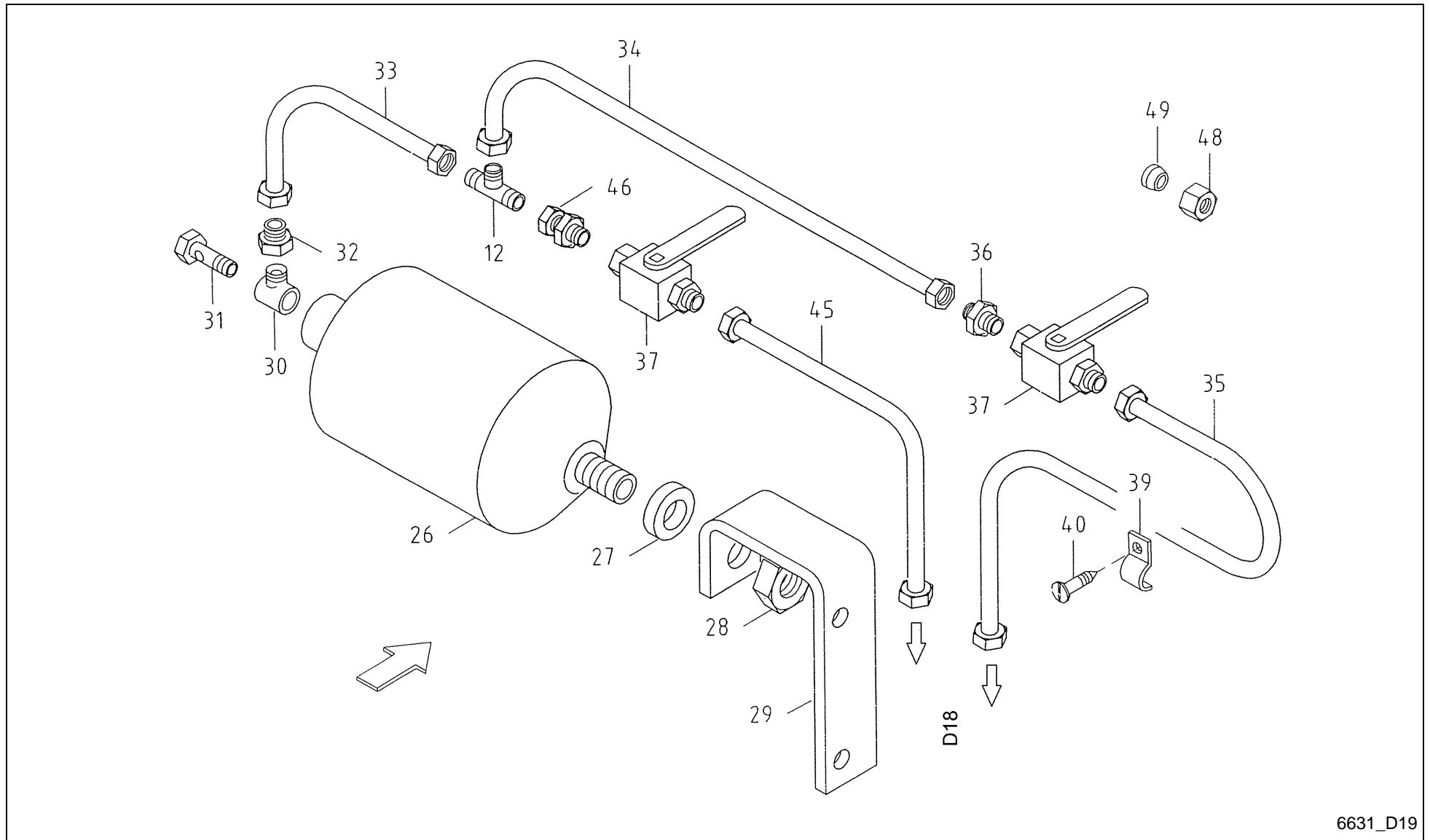

6631_D19



Feedex 360 T / HYDR. FOR DRY FORAGE SUPERST.

PosNo.	Part No.	Qty.	Description	Remark
12	VF01116740	1	NOZZLE XT 8-L GALV.	
26	VF06584800	1	HYDR.ACCUMULATOR	
27	VF06578645	1	RING	
28	VF06209580	1	NUT, HEX	
29	VF16611420	1	RETAINER	
30	VF01167953	1	UNION	
31	VF01167956	1	HOLLOW BOLT	
32	VF01173639	1	REDUCER INSERT	
33	VF16614901	1	HYDR.PIPE	
34	VF16613495	1	HYDR. PIPE	
35	VF16611423	1	HYDR. PIPE	
36	VF01141838	1	SCR.-IN FITTING XGE08LR GALV.	
37	VF01141391	2	VALVE ASSY, SHUT-OFF	
39	VF06216397	1	FIXING CLIP	
40	VF16631049	1	DRILLING SCREW 6.3X19 D7504	
45	VF16613497	1	HYDR. PIPE	
46	VF06217046	1	SCREW-IN FITTING EVGE08LR-ED A3C	
48	VF01127346		UNION NUT H3105-CL 8-ST A3C	
49	VF01116622		CUTTING RING D08L DIN 3861-ST	

Feedex 360 T / HYDR. FOR CRANKED DRAWBAR

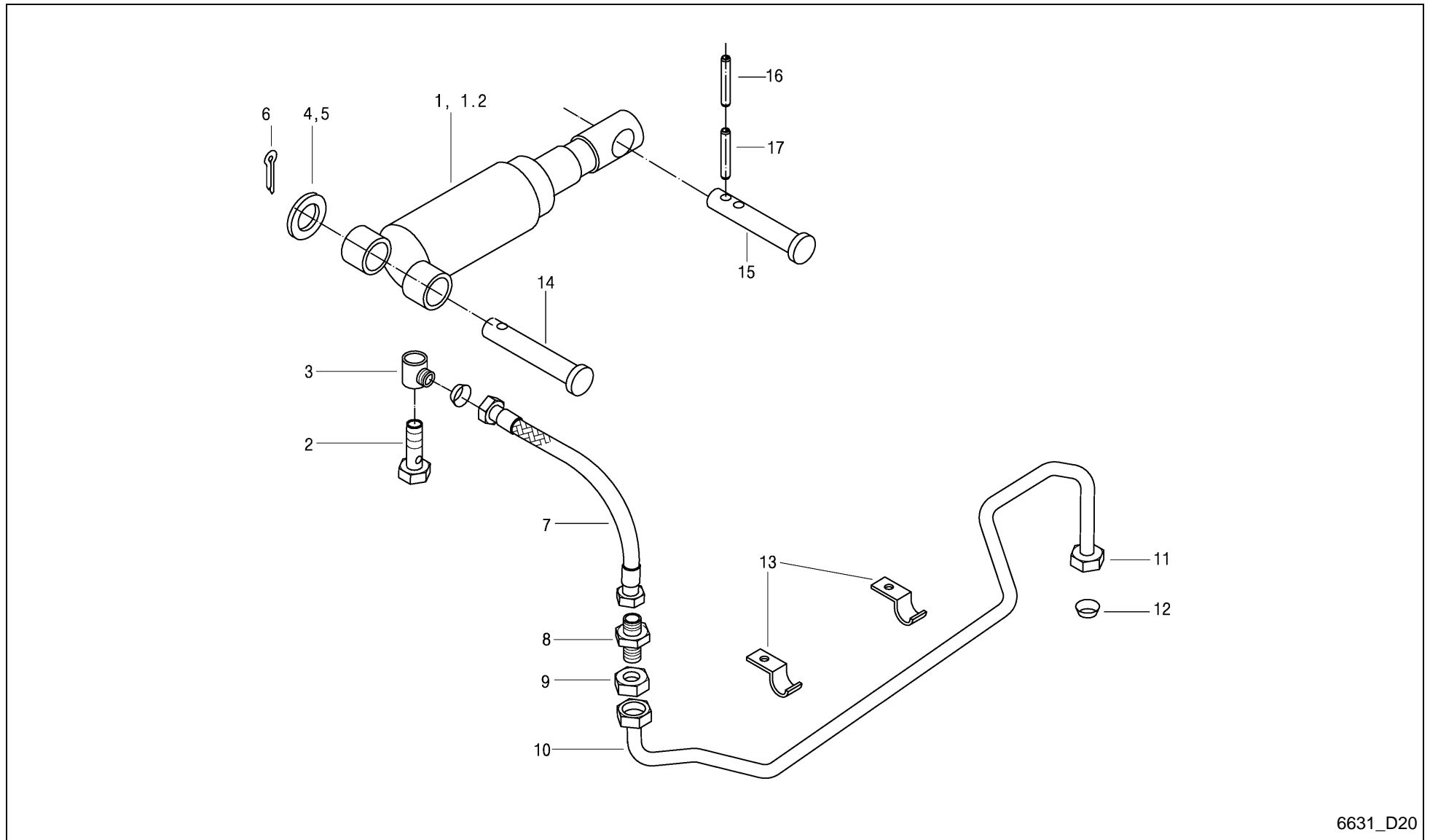

6631_D20



Feedex 360 T / HYDR. FOR CRANKED DRAWBAR

PosNo.	Part No.	Qty.	Description	Remark
1	VF16517146	1	HYDRAULIC CYLINDER	
1.1	VF16511004		SEALING SET	X 1
1.2	VF16630158	1	HYDRAULIC CYLINDER	H.u.P.Dippoldiswald
1.3	VF16630159	1	SEALING SET	X 1.2
2	VF01141296	1	HOLLOW BOLT	
3	VF01141295	1	UNION	
4	VF06214237	1	WASHER	
5	VF06214238	1	WASHER 34X50X5 A2C DIN 1441	
6	VF01106500	1	SPLIT PIN 8X50DIN94 GALV.	
7	VF01142641	1	HYDR. HOSE 0BODN6X 800 DKOL-8L+DKOL-8L	
8	VF01123941	1	STRAIGHT CONNECTOR XSV 8-L CF	
9	VF01121824	1	NUT M14X1,5 GM08L CF	
10	VF16517197	1	HYDR.PIPE	S D21
11	VF01127346		UNION NUT H3105-CL 8-ST A3C	
12	VF01116622		CUTTING RING D08L DIN 3861-ST	
13	VF06216397	2	FIXING CLIP	
14	VF01397555	1	PIN/BOLT/STUD	
15	VF16515159	1	PIN/BOLT/STUD	S F09
16	VF01136930	1	DOWEL PIN	
17	VF01157345	1	DOWEL PIN	

Feedex 360 T / HYDR. STEERING

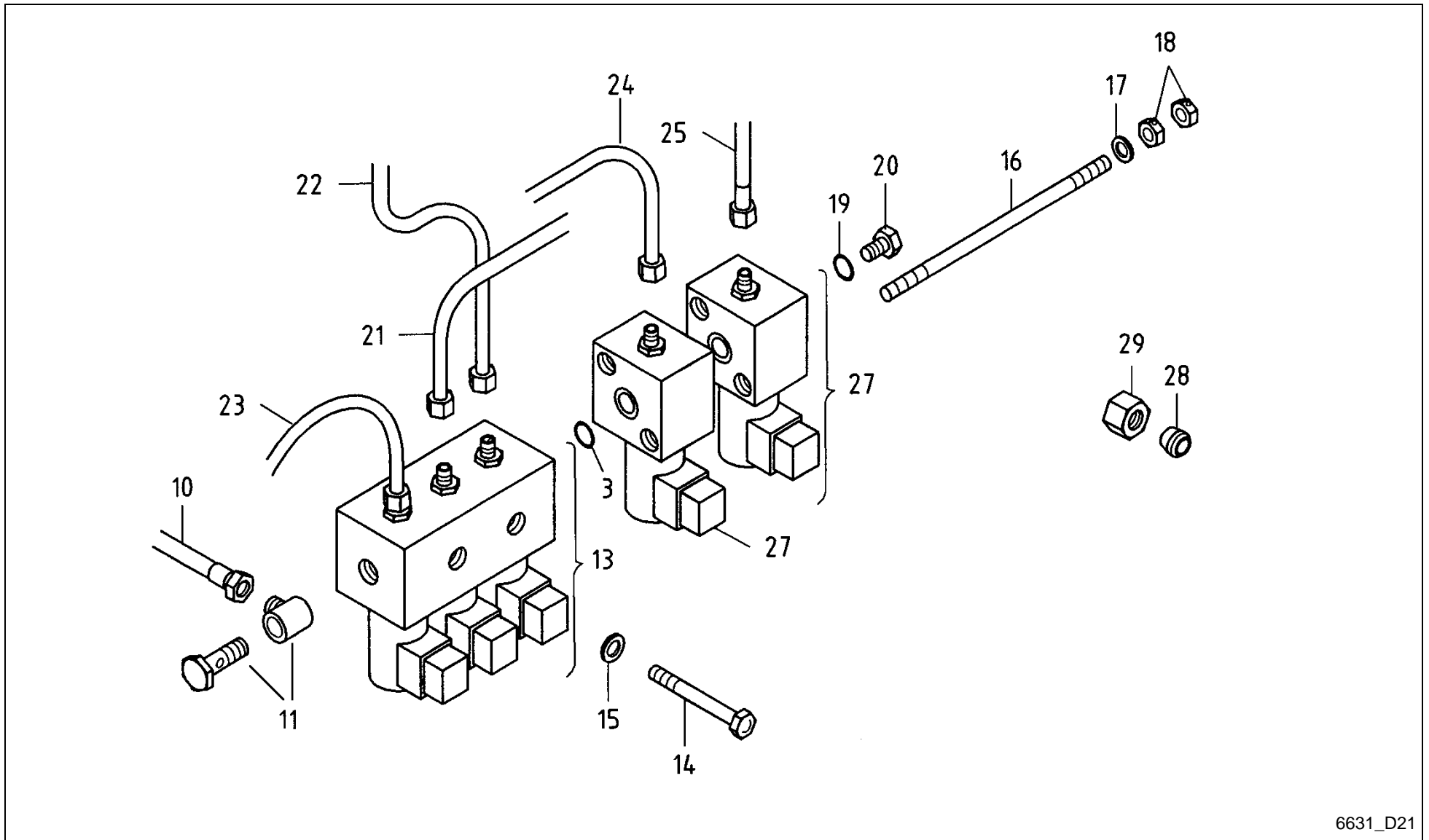

6631_D21



Feedex 360 T / HYDR. STEERING

PosNo.	Part No.	Qty.	Description	Remark
3	VF01169581	1	O-RING	
10	VF16613449	1	HYDR.PIPE	S D15
11	VF16631123	1	UNION 2 PIECE	
13	VF16516558	1	VALVE BLOCK	
14	VF01111168	2	HEX. HEAD SCREW	
15	VF01107163	2	WASHER	
16	VF16610913	2	THREADED PIN	
17	VF01143103	2	WASHER/DISC/PLATE	
18	VF01112824	4	HEX. NUT	
19	VF01118675	1	SEAL RING	
20	VF01143104	1	SCREW PLUG	
21	VF16613313	1	HYDR.PIPE	S D16
22	VF16517193	1	HYDR.PIPE	S D22
23	VF16517194	1	HYDR.PIPE	S D17
24	VF16517197	1	HYDR.PIPE	S D20
25	VF16613246	1	HYDR. HOSE 6X670	S D18
27	VF16631291	2	VALVE BLOCK WITH MANUAL EMERGENCY	
28	VF01116622		CUTTING RING D08L DIN 3861-ST	
29	VF01127346		UNION NUT H3105-CL 8-ST A3C	

Feedex 360 T / HYDRAULIC FOR CONVEYOR

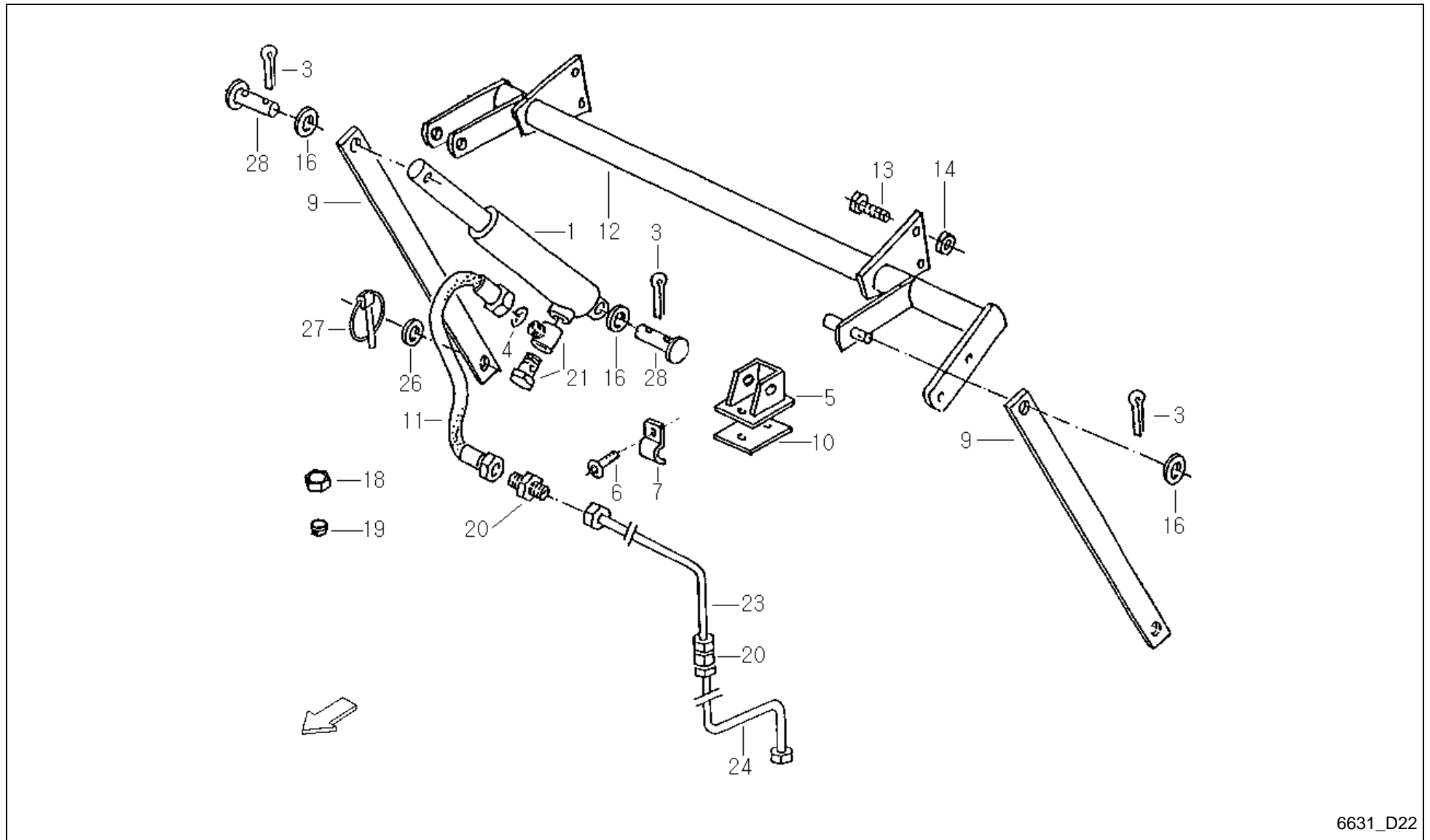

6631_D22

Feedex 360 T / HYDRAULIC FOR CONVEYOR



PosNo.	Part No.	Qty.	Description	Remark
1	VF06587590	1	HYDR.CYLINDER	
1.1	VF06286217		SEALING SET	
3	VF01106451	3	SPLIT PIN	
4	VF06581181	1	RESTRICTOR 1,0 MM D8,0X1	
5	VF06571018	1	BRACKET	
6	VF16631049	3	DRILLING SCREW 6.3X19 D7504	+A 2006
7	VF06216397	3	FIXING CLIP	
9	VF06577584	2	PULL ROD	
10	VF06578830	1	SHIM	
11	VF06571331	1	HYDR. HOSE 0BODN6X 600 DKOL-8L+DKOL-8L	
12	VF06577469	1	TUBE	
13	VF01103341	4	HEX.HEAD SCREW	
14	VF06209778	4	LOCK NUT	
16	VF06214217	3	WASHER 17X28X3DIN1441 GALV.	
18	VF01127346		UNION NUT H3105-CL 8-ST A3C	
19	VF01116622		CUTTING RING D08L DIN 3861-ST	
20	VF01116705	2	CONNECTING SLEEVE XG 8-L CF	
21	VF16631123	1	UNION 2 PIECE	
23	VF06579491	1	HYDR.PIPE	
24	VF16517193	1	HYDR.PIPE	S D21
26	VF06214226	2	WASHER	
27	VF01126332	2	DOWEL PIN	
28	VF01139468	2	PIN	

Feedex 360 T / LUBE SYSTEM

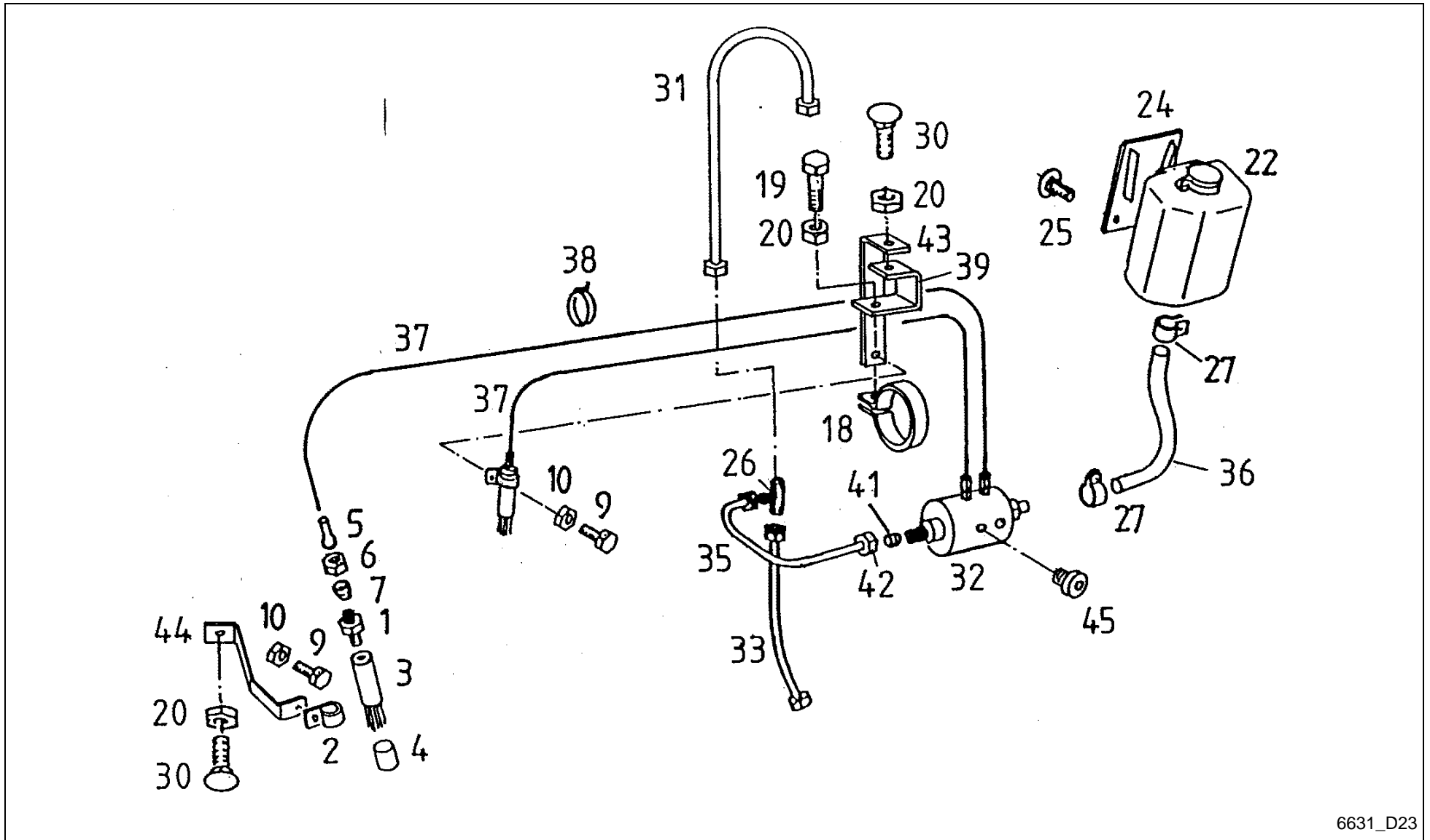

6631_D23



Feedex 360 T / LUBE SYSTEM

PosNo.	Part No.	Qty.	Description	Remark
1	VF06216815	2	NIPPLE	
2	VF01211882	2	PIPE CLIP RSGU1 15X15	
3	VF06551690	2	BRUSH	
4	VF01141235	2	INSULATING HOSE	
5	VF01177316	4	STIFFENING SLEEVE	
6	VF06216773	4	CAP NUT	
7	VF01103117	4	CUTTING RING	
9	VF01103316	2	HEX. HEAD SCREW	
10	VF01114357	2	LOCK NUT	
18	VF01143083	1	PIPE CLIP, 48,55 DIN 71555 RS	
19	VF01112341	1	HEX. HEAD SCREW	
20	VF01104944	3	NY LOCK NUT 8A3CD985	
22	VF06551694	1	TANK	
24	VF06575213	1	RETAINER	
25	VF01397598	2	SELF-TAPPING SCREW	
26	VF01116740	1	NOZZLE XT 8-L GALV.	
27	VF01128266	2	HOSE CLIP	
30	VF01142565	2	TRUSS-HEAD SCR. M8X20 109 GALV.	
31	VF16515591	1	HYDR.PIPE	
32	VF16611359	1	OIL PUMP	
33	VF16515593	1	HYDR.PIPE	
35	VF16611240	1	HYDR.PIPE	
36	VF16611242	1	HOSE	
37	VF06554451	2	PIPE	
38	VF06216479	6	CABLE TIE 150X3,6 SW SNX 2-35	
39	VF16611241	1	RETAINER	
41	VF01116622		CUTTING RING D08L DIN 3861-ST	
42	VF01127346		UNION NUT H3105-CL 8-ST A3C	
43	VF06575216	1	ANGLE PLATE	
44	VF06575217	1	RETAINER	
45	VF16611248	6	BLANK PLUG	

Feedex 360 T / LUBE SYSTEM DRUM WITH 4 RAKES

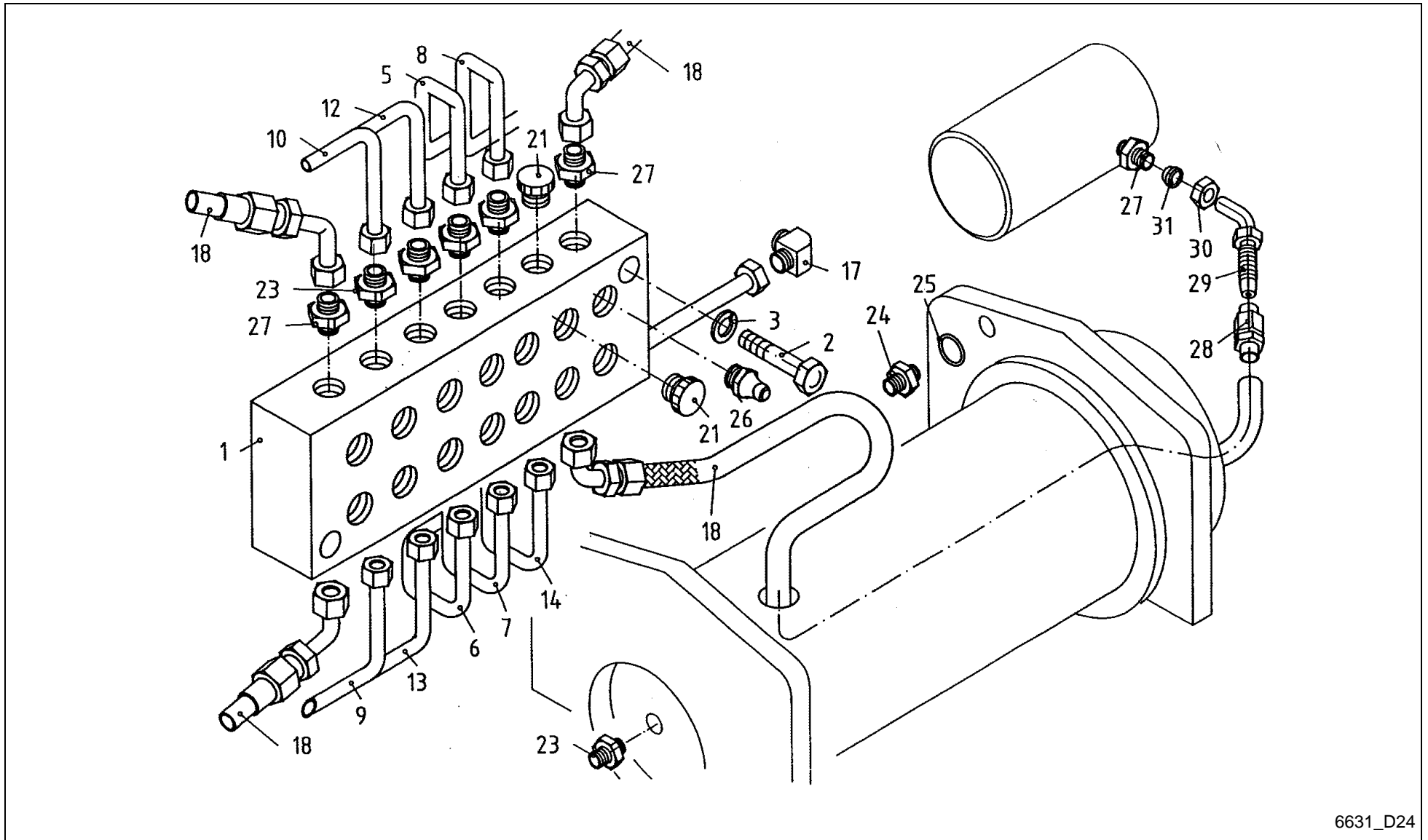

6631_D24

Feedex 360 T / LUBE SYSTEM DRUM WITH 4 RAKES



PosNo.	Part No.	Qty.	Description	Remark
1	VF16516677	1	STRIP	
2	VF01122389	2	HEX.HEAD SCREW	
3	VF01102797	2	SPRING WASHER	
5	VF16516696	1	LUBE TUBE	RECHENLAGER
6	VF16516699	1	LUBE TUBE	RECHENLAGER
7	VF16516700	1	LUBE TUBE	RECHENLAGER
8	VF16516701	1	LUBE TUBE	RECHENLAGER
9	VF16516702	1	LUBE TUBE	FLANSCHZAPFEN
10	VF16516705	1	LUBE TUBE	FLANSCHZAPFEN
12	VF16516706	1	LUBE TUBE	FLANSCHZAPFEN
13	VF16516707	1	LUBE TUBE	FLANSCHZAPFEN
14	VF16516708	1	LUBE TUBE	TROMMELLAGER
17	VF06216854	1	ANGULAR UNION	
18	VF16610926	4	LUBE HOSE	
21	VF06216527	2	PROTECTING PLUG	
23	VF06216815	14	NIPPLE	
24	VF01397760	4	SOCKET/ADAPTER	
25	VF01163589	4	O-RING	
26	VF01120693	13	GREASE FITTING H1 AM 8X1 DIN 71412	
27	VF01397933	8	SOCKET/ADAPTER	
28	VF16516717	4	SCREW SLEEVE	
29	VF16518135	4	PIPE SOCKET	
30	VF01100982	4	UNION NUT	
31	VF01292484	4	SEALING	

Feedex 360 T / LUBE SYSTEM DRUM WITH 6 RAKES

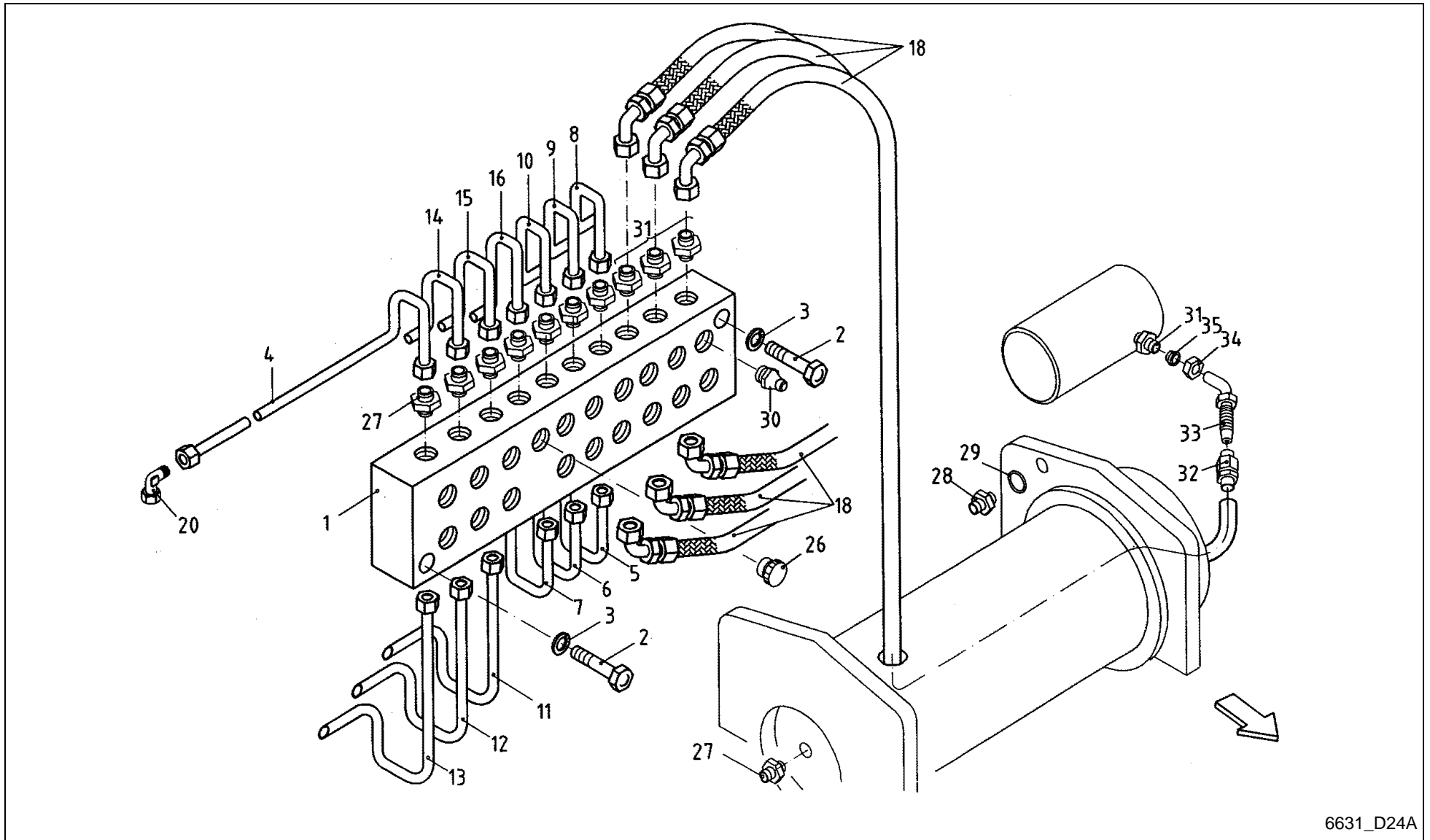

6631_D24A

Feedex 360 T / LUBE SYSTEM DRUM WITH 6 RAKES



PosNo.	Part No.	Qty.	Description	Remark
1	VF16630171	1	RAIL	
2	VF01122389	2	HEX.HEAD SCREW	
3	VF01102797	2	SPRING WASHER	
4	VF16630172	1	LUBRICATION TUBE 1	
5	VF16630174	1	LUBRICATION TUBE 2	
6	VF16630176	1	LUBRICATION TUBE 3	
7	VF16630178	1	LUBRICATION TUBE 4	
8	VF16630180	1	LUBRICATION TUBE 5	
9	VF16630182	1	LUBRICATION TUBE 6	
10	VF16630184	1	LUBRICATION TUBE 7	
11	VF16630186	1	LUBRICATION TUBE 8	
12	VF16630188	1	LUBRICATION TUBE 9	
13	VF16630190	1	LUBRICATION TUBE 10	
14	VF16630192	1	LUBRICATION TUBE 11	
15	VF16630194	1	LUBRICATION TUBE 12	
16	VF16630196	1	LUBRICATION TUBE 13	
18	VF16630200	6	LUBRICATION HOSE 2	
20	VF06216854	1	ANGULAR UNION	
26	VF06216527		PROTECTING PLUG	
27	VF06216815	19	NIPPLE	
28	VF01397760	6	SOCKET/ADAPTER	
29	VF01163589	6	O-RING	
30	VF01120693	19	GREASE FITTING H1 AM 8X1 DIN 71412	
31	VF01397933	12	SOCKET/ADAPTER	
32	VF16516717	6	SCREW SLEEVE	
33	VF16518135	6	PIPE SOCKET	
34	VF01100982	6	UNION NUT	
35	VF01292484	6	SEALING	

Feedex 360 T / LUBE SYSTEM DRUM WITH 5 RAKES

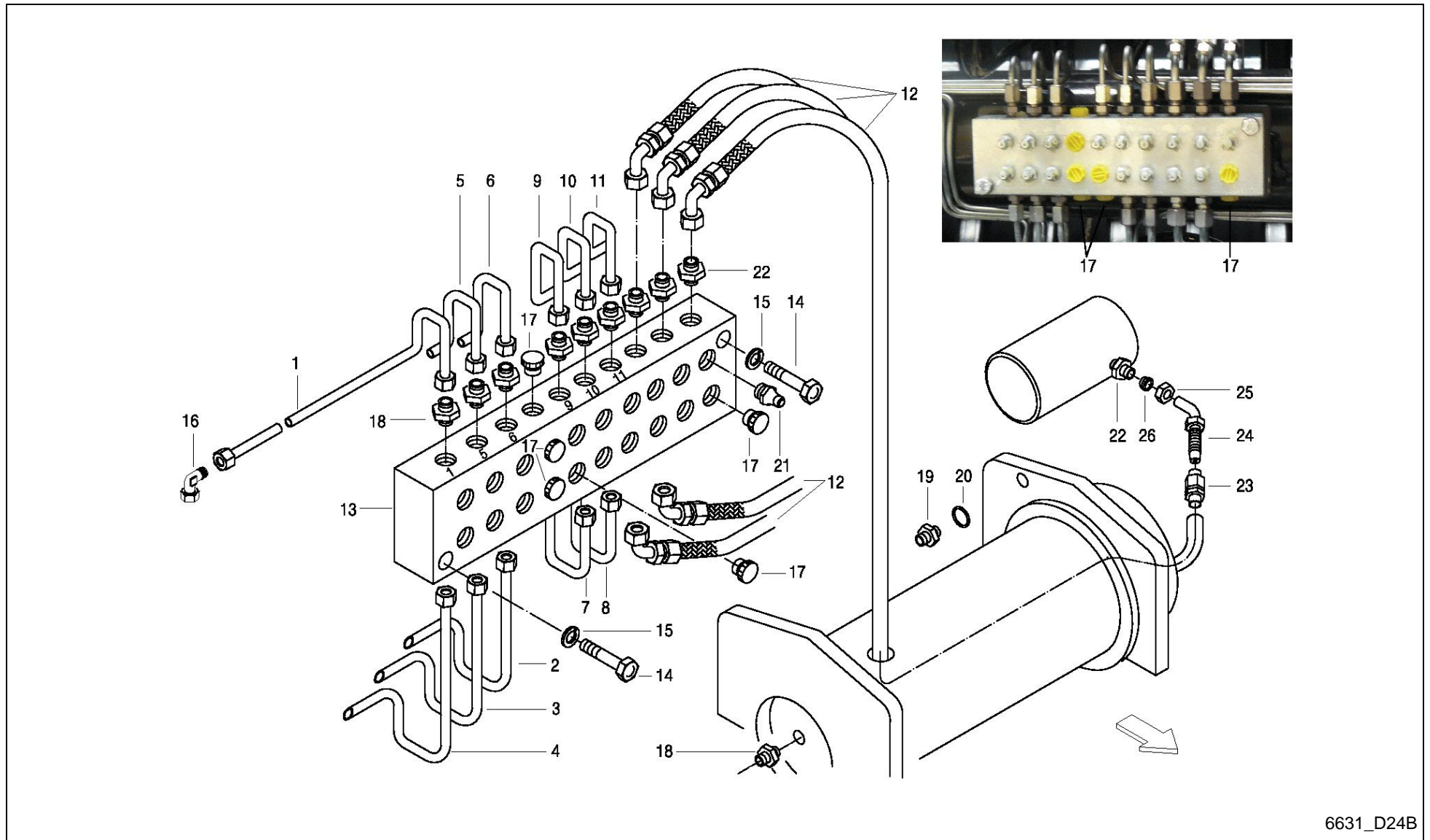

6631_D24B

Feedex 360 T / LUBE SYSTEM DRUM WITH 5 RAKES



PosNo.	Part No.	Qty.	Description	Remark
1	A143012000	1	LUBRICATION TUBE 1	
2	A143012100	1	LUBRICATION TUBE 2	
3	A143012200	1	LUBRICATION TUBE 3	
4	A143012300	1	LUBRICATION TUBE 4	
5	A143012400	1	LUBRICATION TUBE 5	
6	A143012500	1	LUBRICATION TUBE 6	
7	A143012600	1	LUBRICATION TUBE 7	
8	A143012700	1	LUBRICATION TUBE 8	
9	A143012800	1	LUBRICATION TUBE 9	
10	A143012900	1	LUBRICATION TUBE 10	
11	A143013000	1	LUBRICATION TUBE 11	
12	A143013100	5	LUBRICATION HOSE	
13	VF16630171	1	RAIL	
14	VF01122389	2	HEX.HEAD SCREW	
15	VF01102797	2	SPRING WASHER	
16	VF06216854	1	ANGULAR UNION	
17	VF06216527	8	PROTECTING PLUG	
18	VF06216815	19	NIPPLE	
19	VF01397760	6	SOCKET/ADAPTER	
20	VF01163589	6	O-RING	
21	VF01120693	19	GREASE FITTING H1 AM 8X1 DIN 71412	
22	VF01397933	12	SOCKET/ADAPTER	
23	VF16516717	5	SCREW SLEEVE	
24	VF16518135	5	PIPE SOCKET	
25	VF01100982	5	UNION NUT	
26	VF01292484	5	SEALING	

Feedex 360 T / GREEN FODDER SUPERSTRUCTURE SUPPORTS

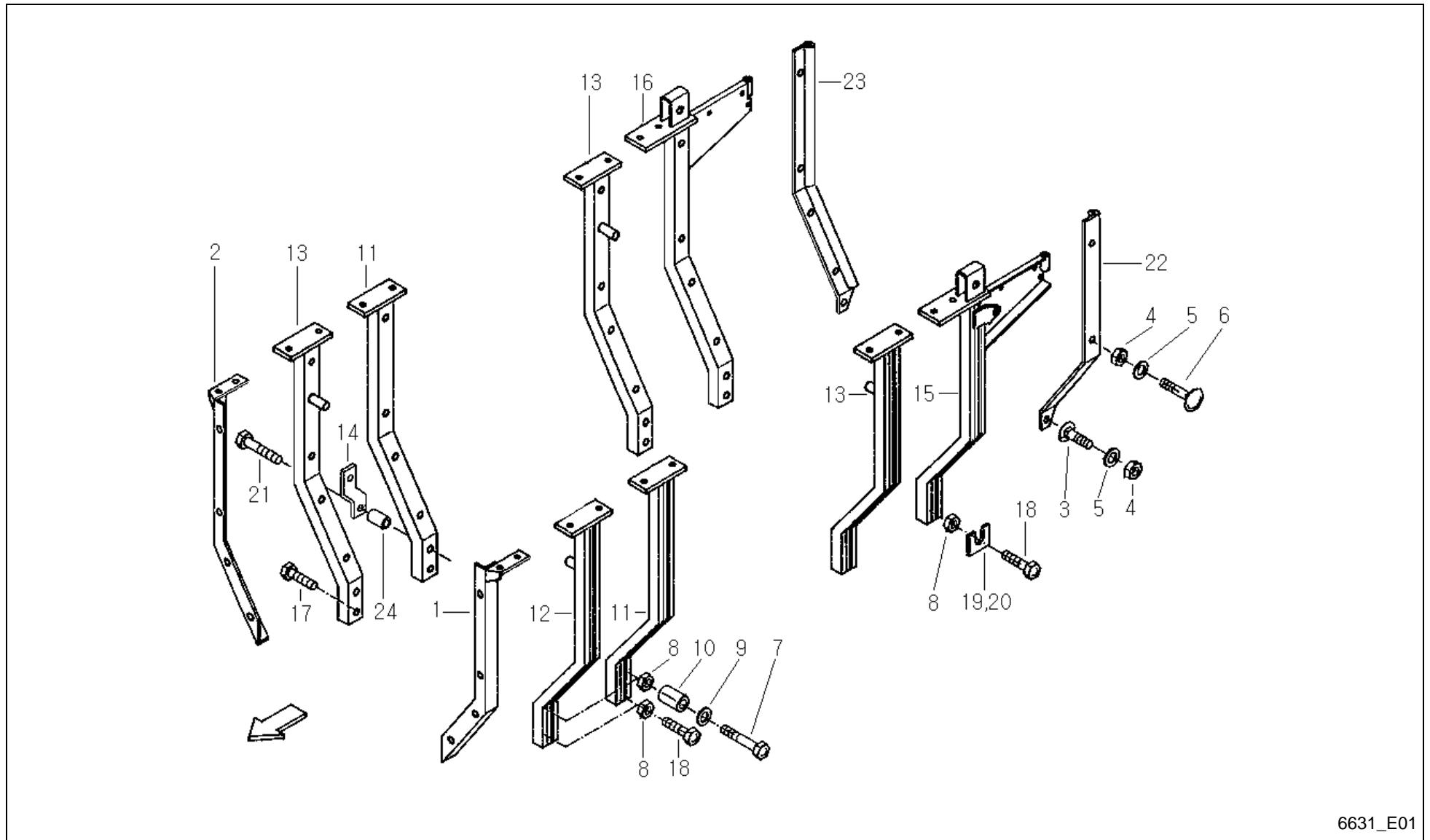

6631_E01

Feedex 360 T / GREEN FODDER SUPERSTRUCTURE SUPPORTS



PosNo.	Part No.	Qty.	Description	Remark
1	VF06577238	1	ECKPROFIL LI. GSW .	
2	VF06577240	1	ECKPROFIL RE. GSW.	
3	VF06207534	2	SCREW	
4	VF01104944	20	NY LOCK NUT 8A3CD985	
5	VF06214192	20	WASHER 8,4X25X3 GALV.	
6	VF06207535	14	OVAL HEADED BOLT	
7	VF06209249	4	SCREW M12X80 D931 10.9 A3CDIN267-27 COAT	
8	VF06209778	26	LOCK NUT	
9	VF06214207	4	WASHER	
10	VF06581494	4	SPACER TUBE	
11	VF06577097	6	SUPPORT	
12	VF06577242	1	SUPPORT	
13	VF06577095	3	SUPPORT	
14	VF16511577	6	CONNECTING PLATE	
15	VF16515902	1	SUPPORT	
16	VF16515904	1	SUPPORT	
17	VF06277504	1	HEX. HEAD SCREW	
18	VF01102701	19	HEX HEAD SCREW	
19	VF06577562	2	SHIM	
20	VF06577563	2	SHIM	
21	VF01139722	6	HEX.BOLT	
22	VF16515926	1	CROSS BAR	
23	VF16515927	1	CROSS BAR	
24	VF16613377	1	SPACING TUBE	

Feedex 360 T / GREEN FODDER SUPERSTRUCTURE - SIDE PANELS (-A 2013)

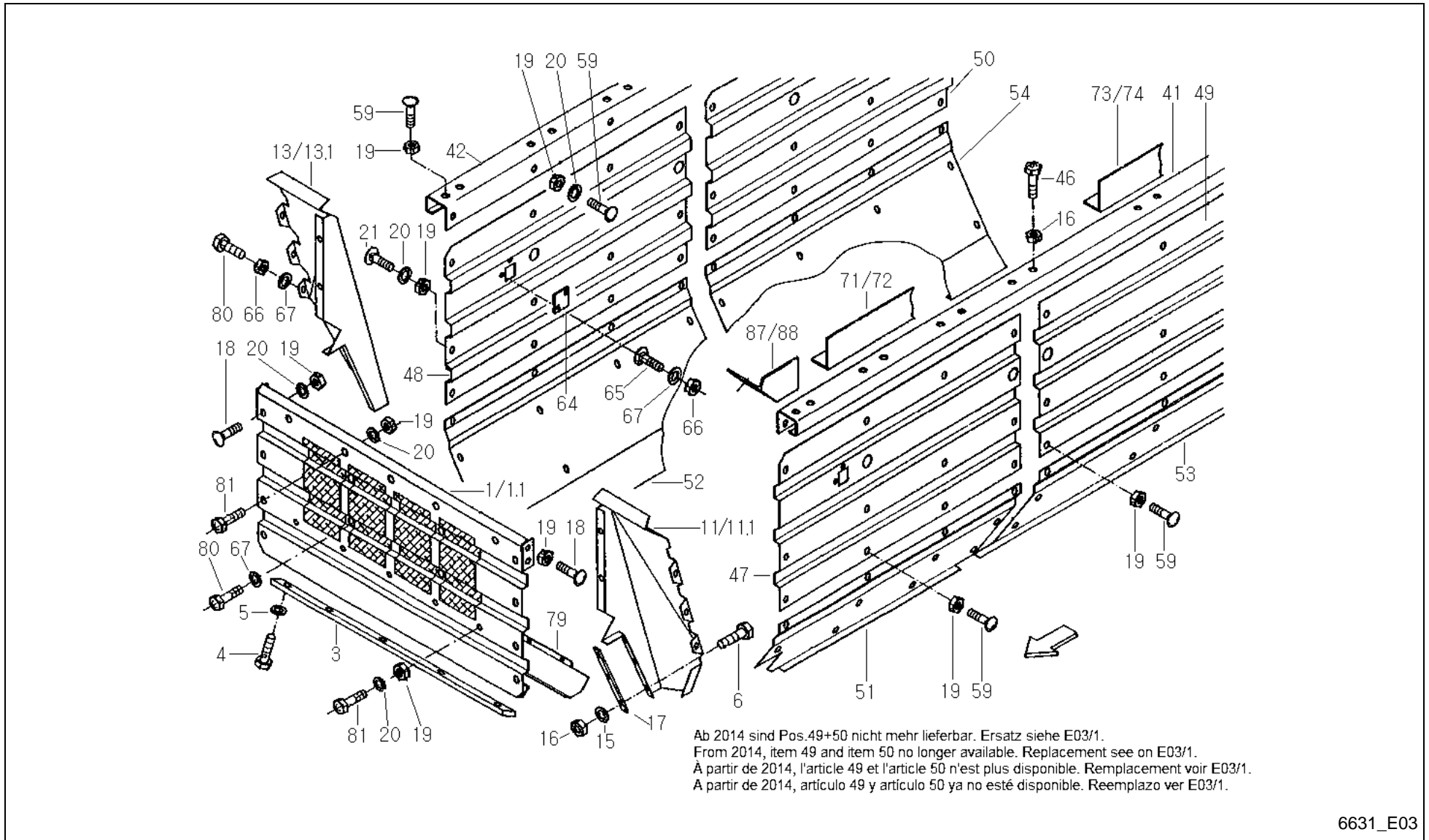

Feedex 360 T / GREEN FODDER SUPERSTRUCTURE - SIDE PANELS (-A 2013)



PosNo.	Part No.	Qty.	Description	Remark
1	VF16516404	1	FRONT WALL	-A 2005
1.1	VF16631340	1	FRONT WALL	+A 2006
3	VF16515928	1	STRIP	
4	VF01111298	7	HEX. HEAD SCREW	
5	VF01127538	4	WASHER	
6	VF01112429	4	HEX. HEAD SCREW	
11	VF16516319	1	CORNER SHEET	-A 2005
11.1	VF16631346	1	DECKBLECH LI	+A 2006
13	VF16516320	1	CORNER SHEET	-A 2005
13.1	VF16631347	1	DECKBLECH RE.	+A 2006
15	VF06214197	4	WASHER 10,5X30X3 GALV.	
16	VF06209768	28	LOCK NUT	
17	VF16516399	1	STRIP	-A 2005
18	VF06207534	20	SCREW	
19	VF01104944	110	NY LOCK NUT 8A3CD985	
20	VF06214192	47	WASHER 8,4X25X3 GALV.	
21	VF06207535	8	OVAL HEADED BOLT	
41	VF16515918	1	CROSS BAR	
42	VF16515920	1	CROSS BAR	
45	VF01112333		HEX. HEAD SCREW	
46	VF01112418	24	BOLT, SCREW	
47	A143032194	1	SIDE PANEL LEFT	
48	A143032294	1	SIDE PANEL RIGHT	
49	VF16515915	1	SIDE WALL	
50	VF16515917	1	SIDE WALL	
51	A143032794	1	SIDE PANEL LEFT	
52	A143032894	1	SIDE PANEL RIGHT	
53	A143032994	1	SIDE PANEL LEFT	
54	A143033094	1	SIDE PANEL RIGHT	
59	VF01142565	92	TRUSS-HEAD SCR. M8X20 109 GALV.	
64	VF06579237	2	PLATE	
65	VF01138989	4	TRUSS-HEAD SCREW	
66	VF01114357	18	LOCK NUT	
67	VF06214189	32	WASHER 6,4X18X2 A2C	
71	VF16611391	1	SHIELD IN FRONT RI.	
72	VF16611392	1	SHIELD IN FRONT LEFT	
73	VF16611394	1	SHIELD BACK RIGHT	
74	VF16611395	1	SHIELD BACK LEFT	
79	VF06572448	1	DEFL.SHEET	-A 2005
80	VF01103316	14	HEX. HEAD SCREW	

Feedex 360 T / GREEN FODDER SUPERSTRUCTURE - SIDE PANELS (-A 2013)

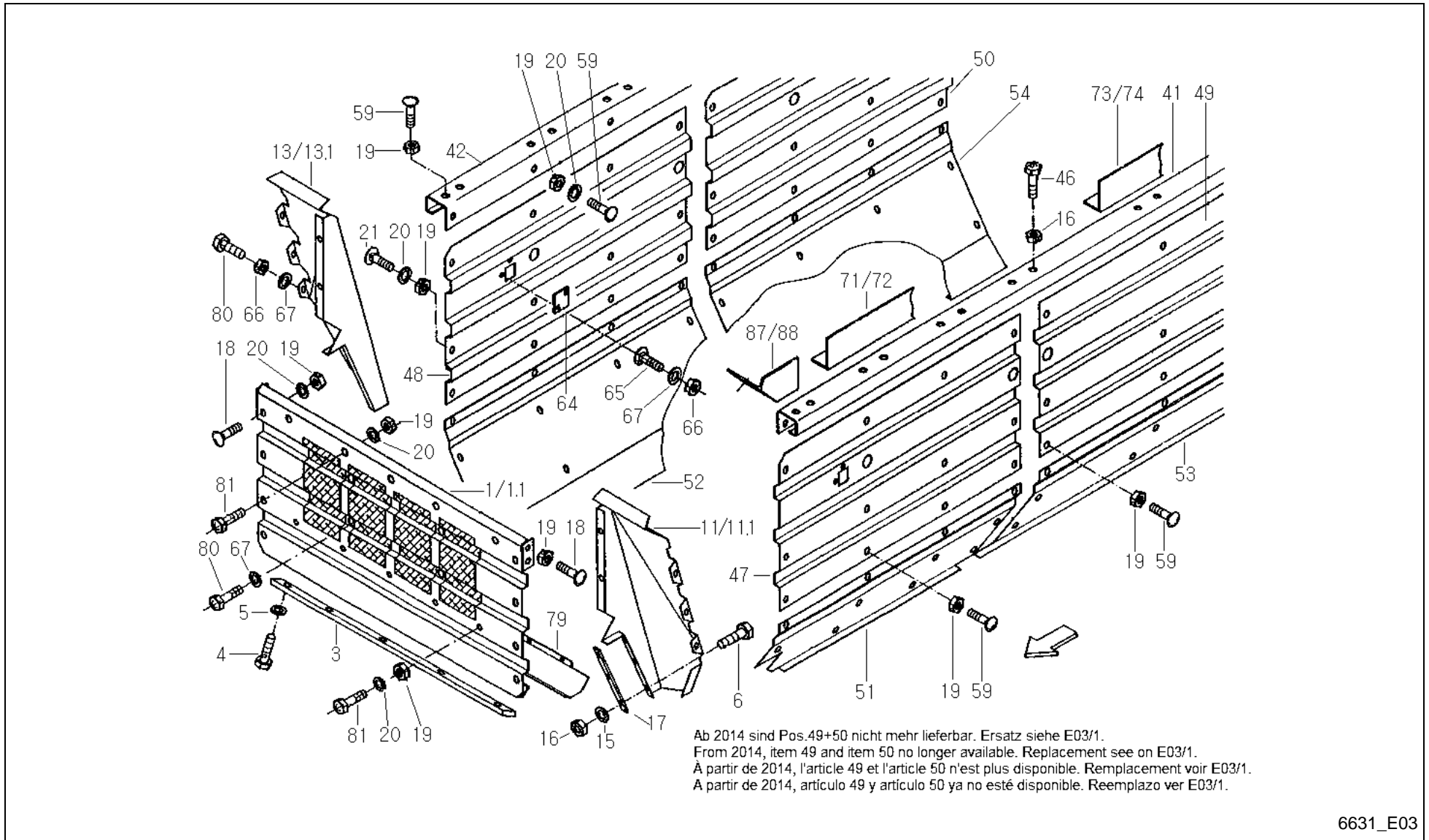

6631_E03

Feedex 360 T / GREEN FODDER SUPERSTRUCTURE - SIDE PANELS (-A 2013)



PosNo.	Part No.	Qty.	Description	Remark
81	VF01112341	3	HEX. HEAD SCREW	
86	VF01107163	4	WASHER	
87	VF16614908	1	ANGLE SHIELD RIGHT	
88	VF16614907	1	ANGLE SHIELD LEFT	

Feedex 360 T / GREEN FODDER SUPERSTRUCTURE - SIDE PANELS (+A 2014)

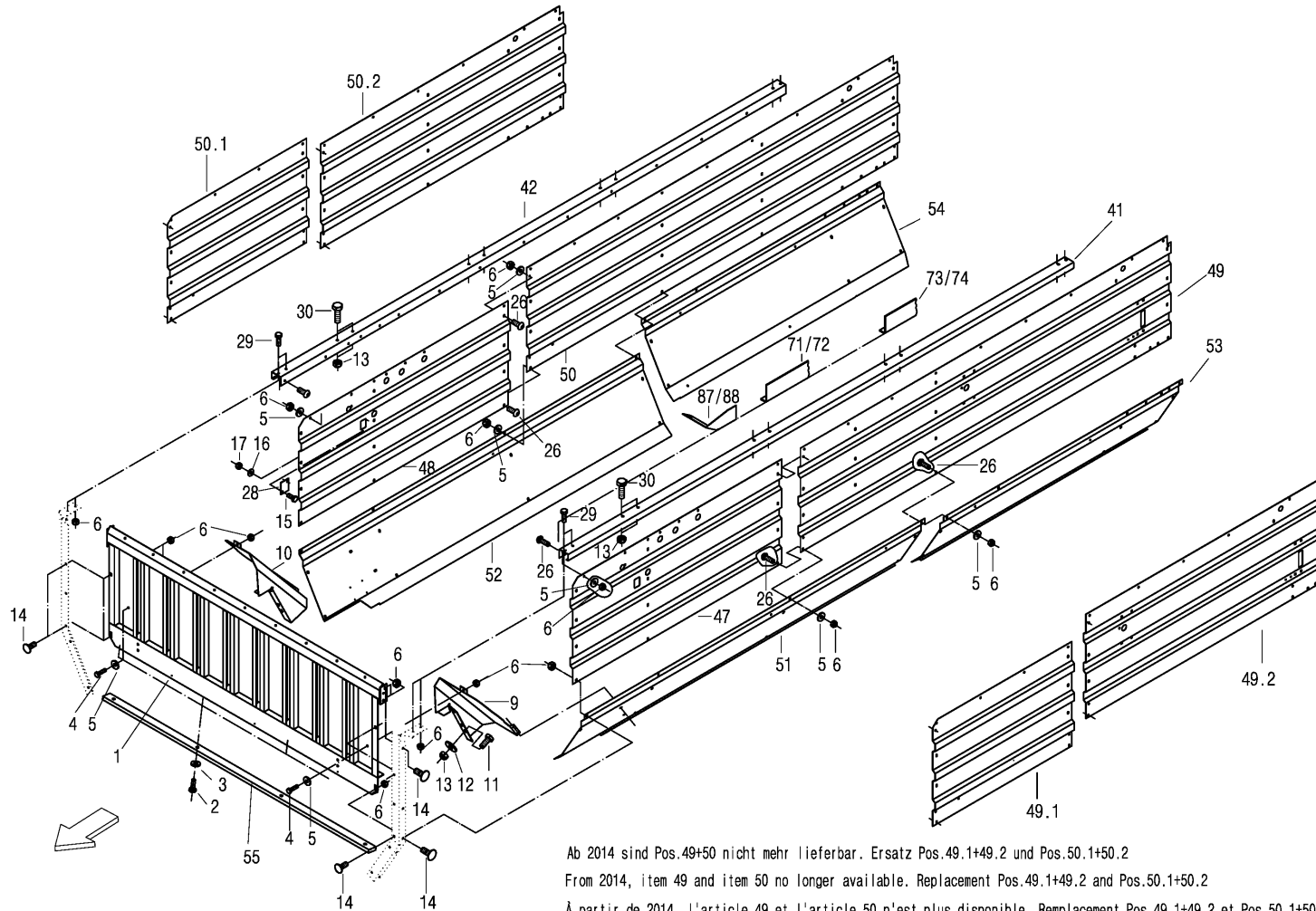

Ab 2014 sind Pos.49+50 nicht mehr lieferbar. Ersatz Pos.49.1+49.2 und Pos.50.1+50.2
 From 2014, item 49 and item 50 no longer available. Replacement Pos.49.1+49.2 and Pos.50.1+50.2
 À partir de 2014, l'article 49 et l'article 50 n'est plus disponible. Remplacement Pos.49.1+49.2 et Pos.50.1+50.2
 A partir de 2014, artículo 49 y artículo 50 ya no está disponible. Reemplazo Pos.49.1+49.2 y Pos.50.1+50.2

6631_E03_1

Feedex 360 T / GREEN FODDER SUPERSTRUCTURE - SIDE PANELS (+A 2014)



PosNo.	Part No.	Qty.	Description	Remark
1	VF16631340	1	FRONT WALL	
2	VF01112429	4	HEX. HEAD SCREW	
3	VF01127538	4	WASHER	
4	VF01112341	2	HEX. HEAD SCREW	
5	VF06214192	50	WASHER 8,4X25X3 GALV.	
6	VF01104944	120	NY LOCK NUT 8A3CD985	
9	VF16631346	1	DECKBLECH LI	
10	VF16631347	1	DECKBLECH RE.	
11	VF01112418	24	BOLT, SCREW	
12	VF06214197	8	WASHER 10,5X30X3 GALV.	
13	VF06209768	24	LOCK NUT	
14	VF06207534	14	SCREW	
15	VF01138989	4	TRUSS-HEAD SCREW	
16	VF06214189	4	WASHER 6,4X18X2 A2C	
17	VF01114357	4	LOCK NUT	
26	VF01142565	98	TRUSS-HEAD SCR. M8X20 109 GALV.	
28	VF06579237	2	PLATE	
29	VF01112333	4	HEX. HEAD SCREW	
30	VF01112429	16	HEX. HEAD SCREW	
41	VF16515918	1	CROSS BAR	
42	VF16515920	1	CROSS BAR	
47	A143032194	1	SIDE PANEL LEFT	
48	A143032294	1	SIDE PANEL RIGHT	
49	VF16515915	1	SIDE WALL	-A 2013
49.1	A143032394	1	SIDE PANEL LEFT UP MIDDLE	+A 2014
49.2	A143032494	1	SIDE PANEL LEFT UP REAR	+A 2014
50	VF16515917	1	SIDE WALL	-A 2013
50.1	A143032594	1	SIDE PANEL RIGHT UP MIDDLE	+A 2014
50.2	A143032694	1	SIDE PANEL RIGHT UP REAR	+A 2014
51	A143032794	1	SIDE PANEL LEFT	
52	A143032894	1	SIDE PANEL RIGHT	
53	A143032994	1	SIDE PANEL LEFT	
54	A143033094	1	SIDE PANEL RIGHT	
55	VF16515928	1	STRIP	
71	VF16611391	1	SHIELD IN FRONT RI.	
72	VF16611392	1	SHIELD IN FRONT LEFT	
73	VF16611394	1	SHIELD BACK RIGHT	
74	VF16611395	1	SHIELD BACK LEFT	
87	VF16614908	1	ANGLE SHIELD RIGHT	
88	VF16614907	1	ANGLE SHIELD LEFT	

Feedex 360 T / HYDR. ADJUSTEMENT OF BACK NET UNIT

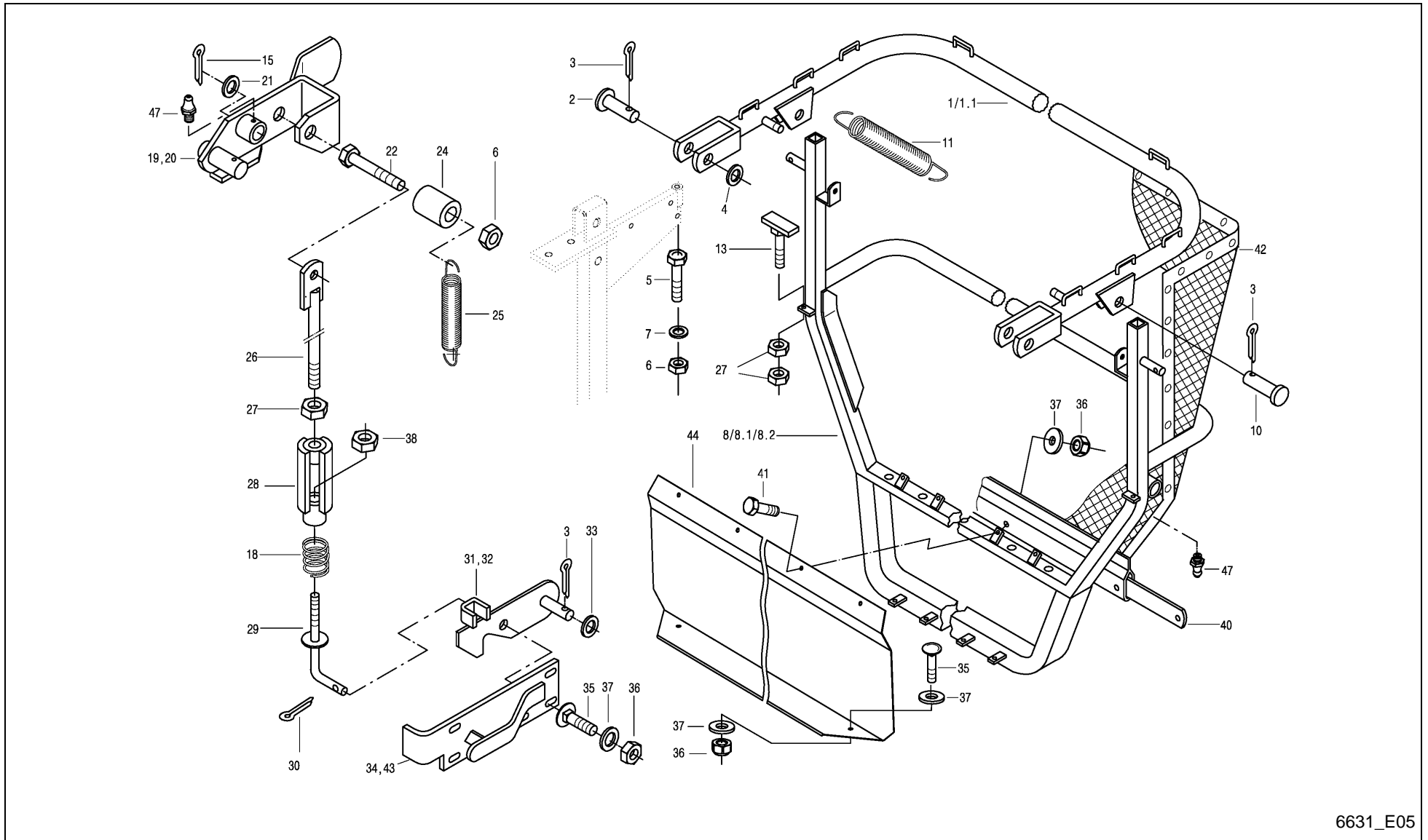

6631_E05



Feedex 360 T / HYDR. ADJUSTEMENT OF BACK NET UNIT

PosNo.	Part No.	Qty.	Description	Remark
1	VF16515938	1	FRONT YOKE	
1	VF16630236	1	TAILGATE BOW	+A 10/2001
2	VF06210032	2	BOLT DIN1434-16H11X 70X 65 FE+ZN	
3	VF01106451	4	SPLIT PIN	
4	VF06214215	2	WASHER 18X30X1,5 GALV.	
5	VF01111514	2	HEX. HEAD SCREW	
6	VF06209769	4	LOCK NUT	
7	VF06214207	2	WASHER	
8	VF16611322	1	FRONT YOKE	ersetzt durch 8.1+44
8.1	VF16630134	1	REAR WALL	
8.2	VF16630234	1	REAR WALL	+A 10/2001
10	VF01139468	2	PIN	
11	VF16611055	2	DRAW SPRING	
13	VF16630757	2	STOP	+A 01/2001
15	VF01122072	2	SPLIT PIN	
18	VF06215315	2	COMPRESSION SPRING	
19	VF16611351	1	ADJUSTING LEVER	
20	VF16611352	1	ADJUSTING LEVER	
21	VF01115021	2	WASHER	
22	VF01111527	2	HEX. HEAD SCREW	
24	VF16611418	2	PIPE/TUBE	
25	VF16611054	2	DRAW SPRING	
26	VF16611335	2	PULLROD	
27	VF01102659	6	HEX. NUT	
28	VF16611341	2	TURNBUCKLE	
29	VF16611338	2	HOOK	
30	VF01132621	2	SPLIT PIN	
31	VF16611325	1	RATCHET/PAWL	
32	VF16611326	1	RATCHET/PAWL	
33	VF01124633	2	WASHER	
34	VF16611330	1	HINGED PIECE	
35	VF01142565	17	TRUSS-HEAD SCR. M8X20 109 GALV.	
36	VF01104944	25	NY LOCK NUT 8A3CD985	
37	VF06214192	25	WASHER 8,4X25X3 GALV.	
38	VF06209768	2	LOCK NUT	
40	VF16515959	1	STRIP	
41	VF01112333	8	HEX. HEAD SCREW	
42	VF16515988	1	BACK NET	
42.1	VF16630237	1	RÜCKWANDBESPANNUNG K7,30/36/39	+A 10/2001
43	VF16611331	1	HINGED PIECE	

Feedex 360 T / HYDR. ADJUSTEMENT OF BACK NET UNIT

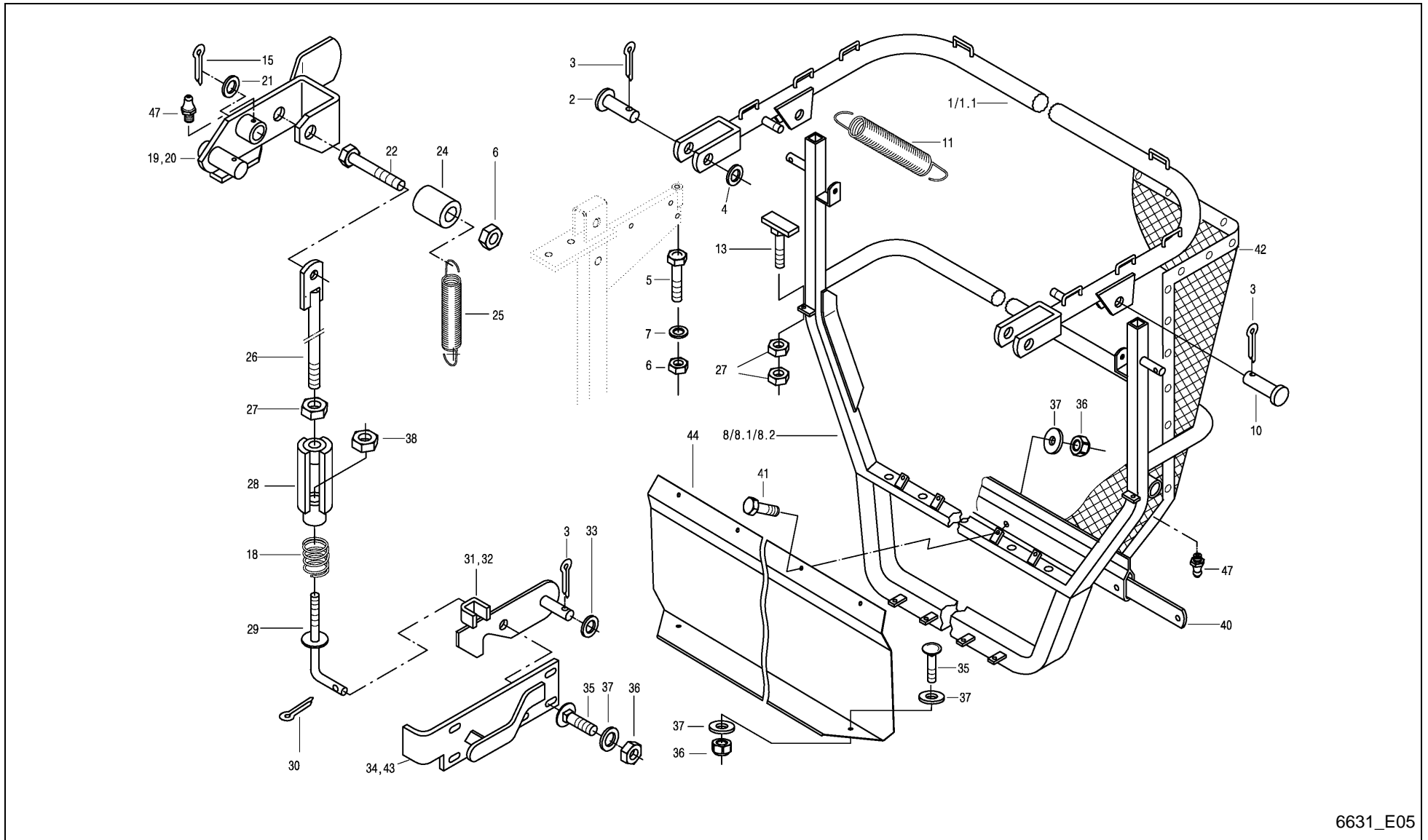

6631_E05

Feedex 360 T / HYDR. ADJUSTEMENT OF BACK NET UNIT



PosNo.	Part No.	Qty.	Description	Remark
44	A143031594	1	COVERING SHEET	
47	VF01120692	4	GREASE NIPPLE H1 AM 6X1 DIN 71412	

Feedex 360 T / DRY FORAGE SUPERST. YOKE-PROFILED TUBE

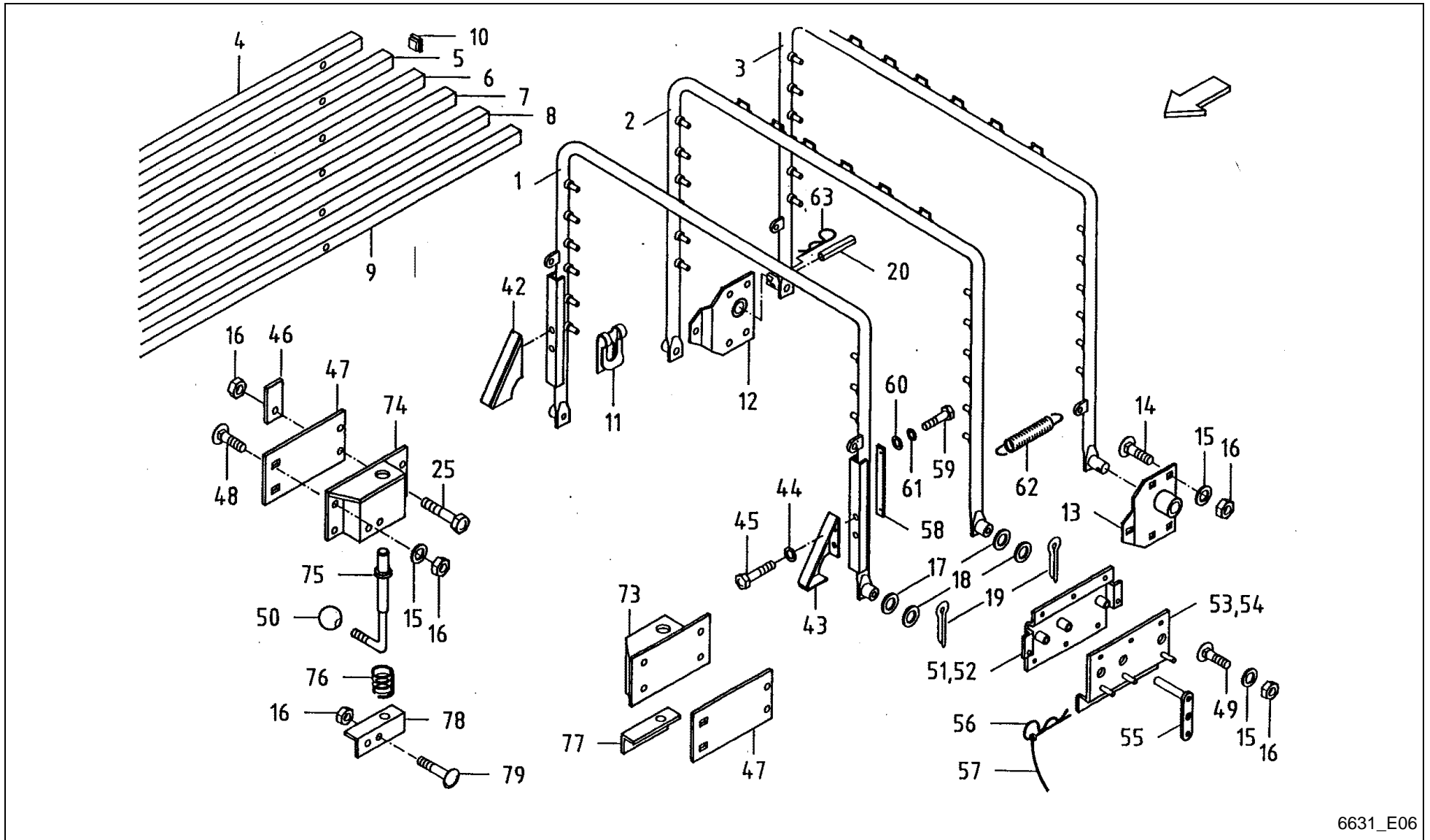

6631_E06

Feedex 360 T / DRY FORAGE SUPERST. YOKE-PROFILED TUBE



PosNo.	Part No.	Qty.	Description	Remark
1	VF16613405	1	YOKE	
2	VF16613406	1	YOKE	
3	VF16613408	1	YOKE	
4	VF16613409	2	PROFILED TUBE	
5	VF16613410	2	PROFILED TUBE	
6	VF16613411	2	PROFILED TUBE	
7	VF16613412	2	PROFILED TUBE	
8	VF16613413	2	PROFILED TUBE	
9	VF16613499	2	PROFILED TUBE	
10	VF16611490	24	SQUARE PLUG	
11	VF06214633	36	SEEGER RING	
12	VF06577154	1	BEARING	
13	VF06577152	1	BEARING	
14	VF06207534	10	SCREW	
15	VF06214192	26	WASHER 8,4X25X3 GALV.	
16	VF01104944	34	NY LOCK NUT 8A3CD985	
17	VF06214229	5	WASHER 21X32X2 GALV.	
18	VF06214228	4	WASHER 21X32X1 GALV.	
19	VF01122072	5	SPLIT PIN	
20	VF01157337	1	DOWEL PIN	
25	VF01112341	4	HEX. HEAD SCREW	
42	VF16614921	1	ANGLED STOP	
43	VF16614920	1	ANGLED STOP	
44	VF01107105	8	WASHER	
45	VF06209465	4	SCR. M10X20D933 8.8 GALV. DIN267-27	
46	VF06577183	2	SPACER	
47	VF16613464	2	PLATE	
48	VF01137628	4	SAUCER HEAD SCREW	
49	VF01142856	16	CUP SQR. BOLT M8X25DIN7380-2 10.9 GALV.	
50	VF06205968	2	BALL HANDLE	
51	VF16613418	1	SUPPORT RIGHT	
52	VF16613417	1	SUPPORT LEFT	
53	VF16613422	1	SUPPORT RIGHT	
54	VF16613421	1	SUPPORT LEFT	
55	VF16613427	4	PIN	
56	VF06264206	4	SPRING	
57	VF06564448	4	CORD L= 240 COLOUR BLACK	
58	VF16613432	2	STOP	
59	VF01123749	4	HEX. HEAD SCREW	
60	VF01107095	4	WASHER 6,4DIN125 GALV.	

Feedex 360 T / DRY FORAGE SUPERST. YOKE-PROFILED TUBE

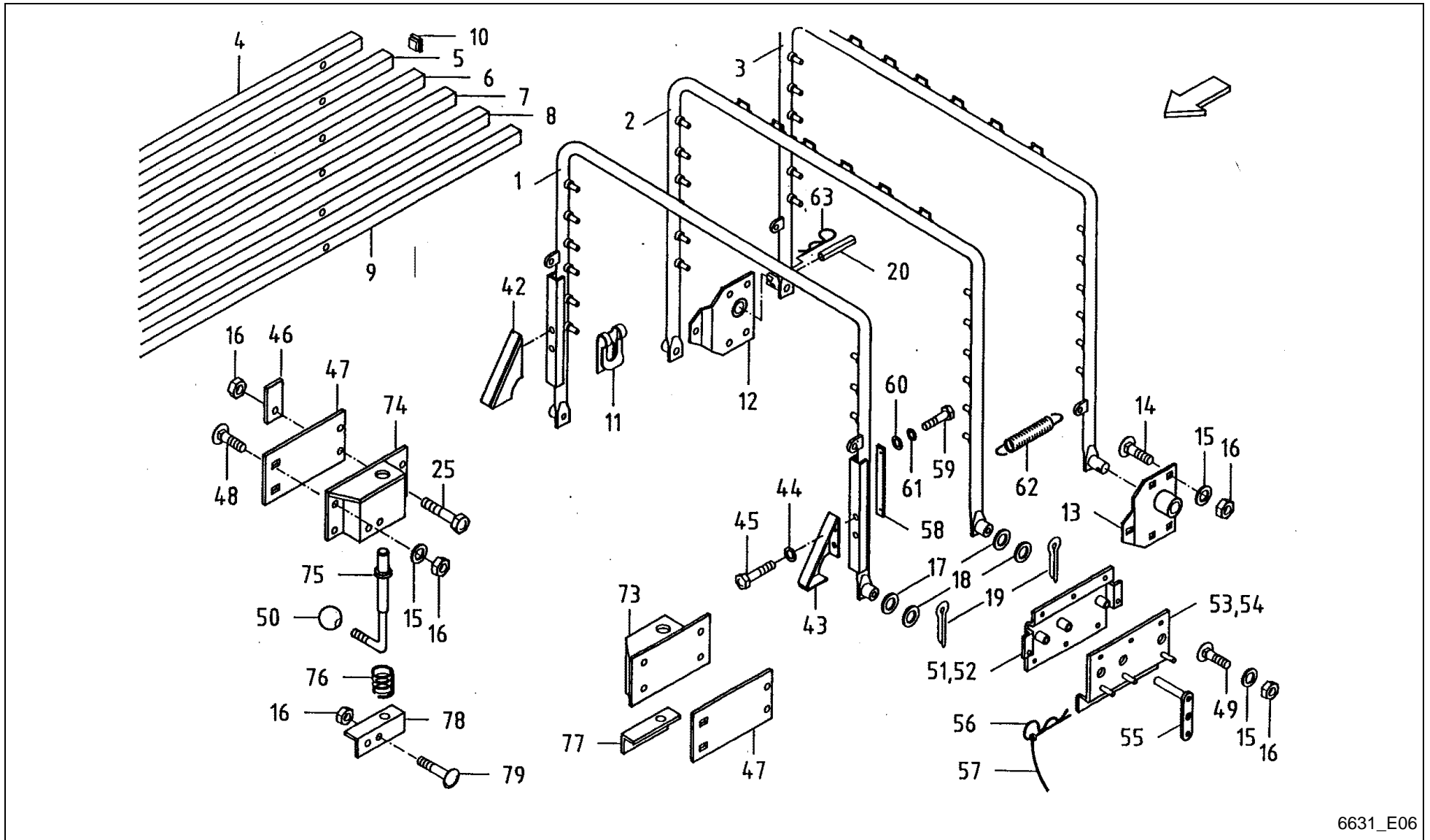

6631_E06

Feedex 360 T / DRY FORAGE SUPERST. YOKE-PROFILED TUBE



PosNo.	Part No.	Qty.	Description	Remark
61	VF01102797	4	SPRING WASHER	
62	VF06215565	2	TENSION SPRING 4,7 + 30,0 + 339 GA. ZI.	
63	VF06215666	1	SPRING CLIP	
73	VF06578992	1	CASE/BOX	
74	VF06578993	1	CASE/BOX	
75	VF06577192	2	FIXING PIN	
76	VF01141455	2	SPRING SUPERSTRUCTURE	
77	VF06577181	1	FIXING ANGLE	
78	VF06577182	1	FIXING ANGLE	
79	VF01108524	4	SCREW	

Feedex 360 T / DRY FORAGE SUPERST. CANVAS AND CABLES

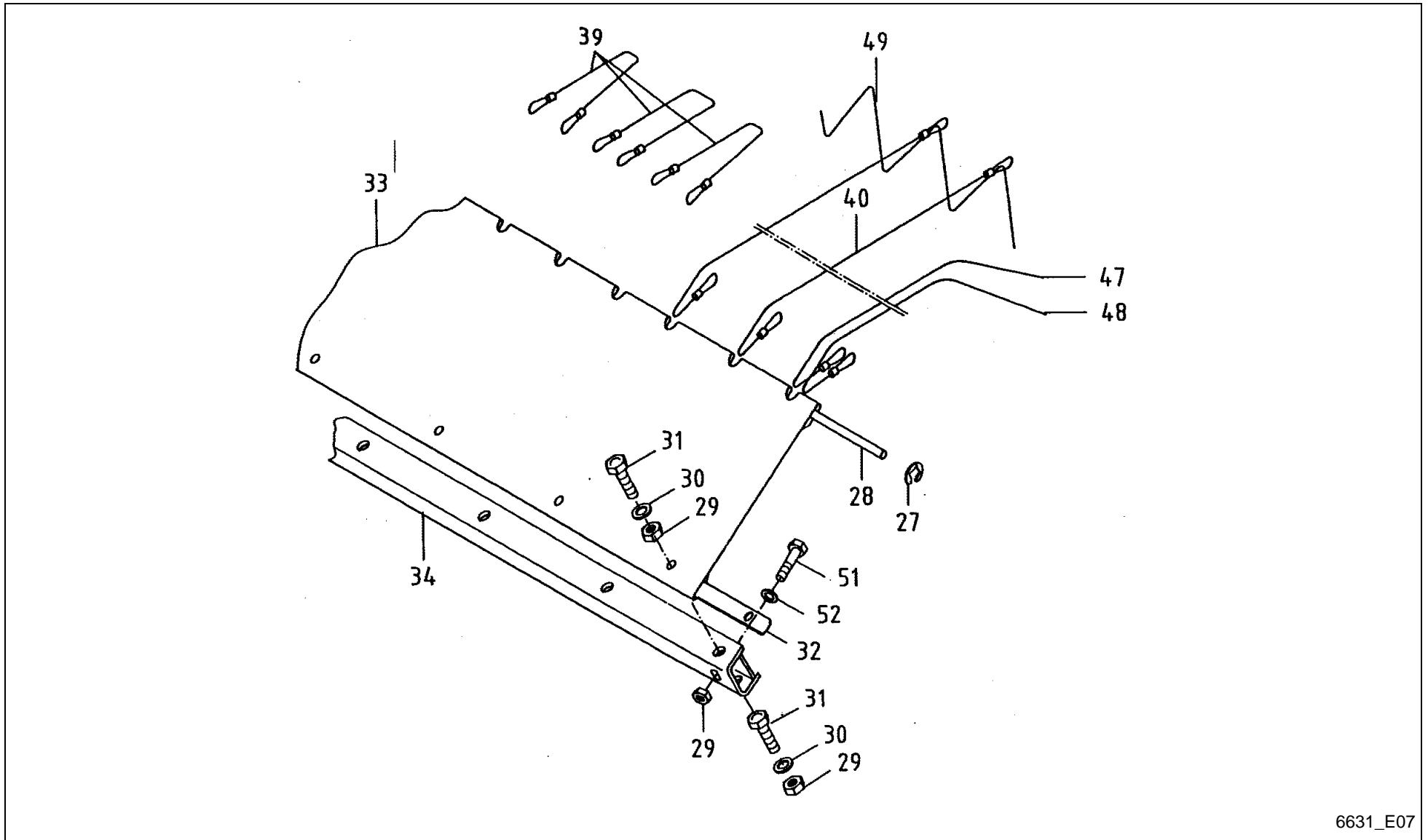

6631_E07

Feedex 360 T / DRY FORAGE SUPERST. CANVAS AND CABLES



PosNo.	Part No.	Qty.	Description	Remark
27	VF06587375	2	WASHER	
28	VF06587374	1	ROD	
29	VF01104944	22	NY LOCK NUT 8A3CD985	
30	VF06214192	18	WASHER 8,4X25X3 GALV.	
31	VF01112333	18	HEX. HEAD SCREW	
32	VF06577184	1	BAR	
33	VF06578646	1	FRONT CANVAS	
34	VF16613493	1	EXTENSION	
39	VF06587674	3	WIRE CABLE	
40	VF06587672	10	CABLE/ROPE	
47	VF16613469	2	CABLE/ROPE	
48	VF16613470	2	CABLE/ROPE	
49	VF16630219	1	CORD PE 6X20000MM	
51	VF01112322	4	HEX. HEAD SCREW	
52	VF01107163	8	WASHER	

Feedex 360 T / LEVEL INDICATOR

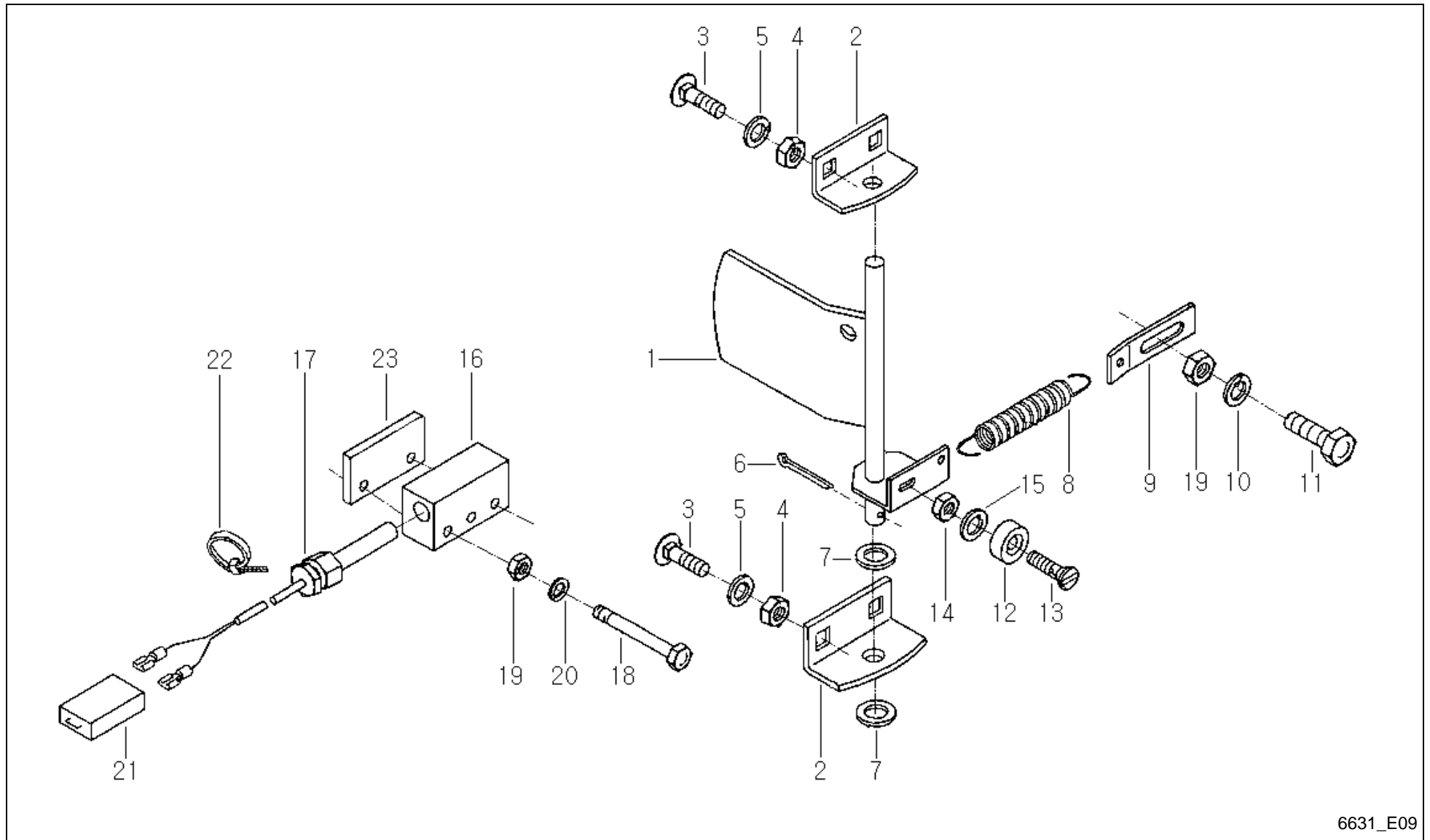

6631_E09



Feedex 360 T / LEVEL INDICATOR

PosNo.	Part No.	Qty.	Description	Remark
1	VF16518205	1	FLAP/COVER	
2	VF16511632	2	RETAINER	
3	VF06207535	4	OVAL HEADED BOLT	
4	VF01104944	4	NY LOCK NUT 8A3CD985	
5	VF01107163	4	WASHER	
6	VF01106451	1	SPLIT PIN	
7	VF06214215	2	WASHER 18X30X1,5 GALV.	
8	VF06215513	1	TENSION SPRING	
9	VF16511633	1	CONNECTING PLATE	
10	VF06214189	1	WASHER 6,4X18X2 A2C	
11	VF01103316	1	HEX. HEAD SCREW	
12	VF16514462	1	MAGNET/SOLENOID	
13	VF01132262	1	C SUNK SCREW	
14	VF06209764	1	HEX.NUT	
15	VF01119806	1	WASHER/DISC/PLATE	
16	VF16517215	1	SWITCH HOUSING	
17	VF16518210	1	IGNITION SWITCH	
18	VF01111083	2	HEX. HEAD SCREW	
19	VF01114357	3	LOCK NUT	
20	VF06214189	2	WASHER 6,4X18X2 A2C	
21	VF01169436		CABLE-CONNECTOR	
22	VF06216479	6	CABLE TIE 150X3,6 SW SNX 2-35	
23	VF16630487	1	DISTANCE PLATE	

Feedex 360 T / RIGID MOUNTING, CANVAS AND CABLES

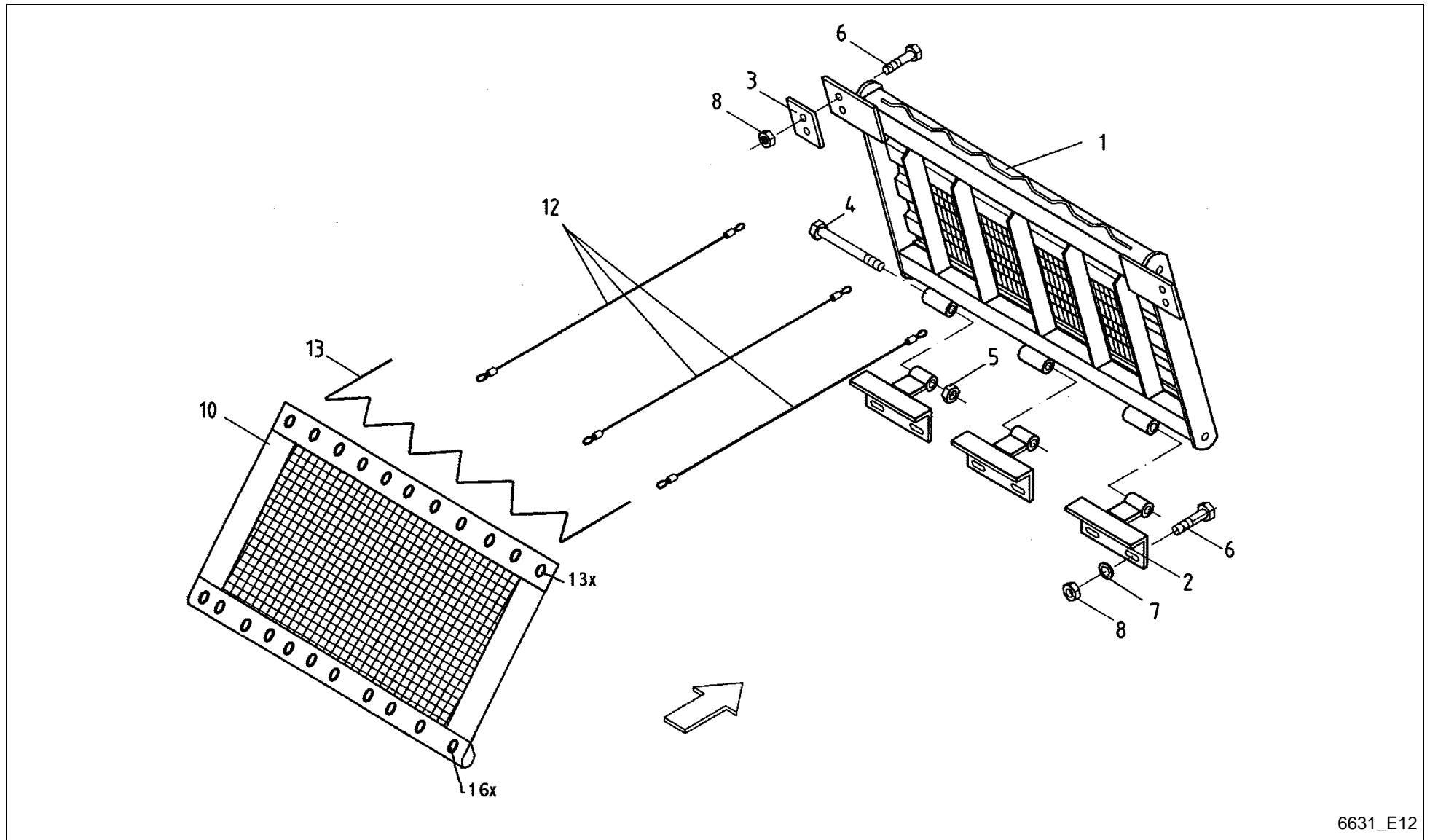

6631_E12

Feedex 360 T / RIGID MOUNTING, CANVAS AND CABLES



PosNo.	Part No.	Qty.	Description	Remark
1	VF16515605	1	AIR CLEANER	
2	VF16515614	3	HINGE ANGLE	
3	VF16515613	2	PACHED PLATE	
4	VF01111576	3	SCREW M 12 X 120D931 8 8A3C	
5	VF06209769	3	LOCK NUT	
6	VF01112341	10	HEX. HEAD SCREW	
7	VF06214193	6	WASHER 8,4X21X3 GALV.	
8	VF01104944	10	NY LOCK NUT 8A3CD985	
10	VF16630216	1	NET REAR	
12	VF16630217	14	CORD PE 6X4150MM	
13	VF16630219	1	CORD PE 6X20000MM	

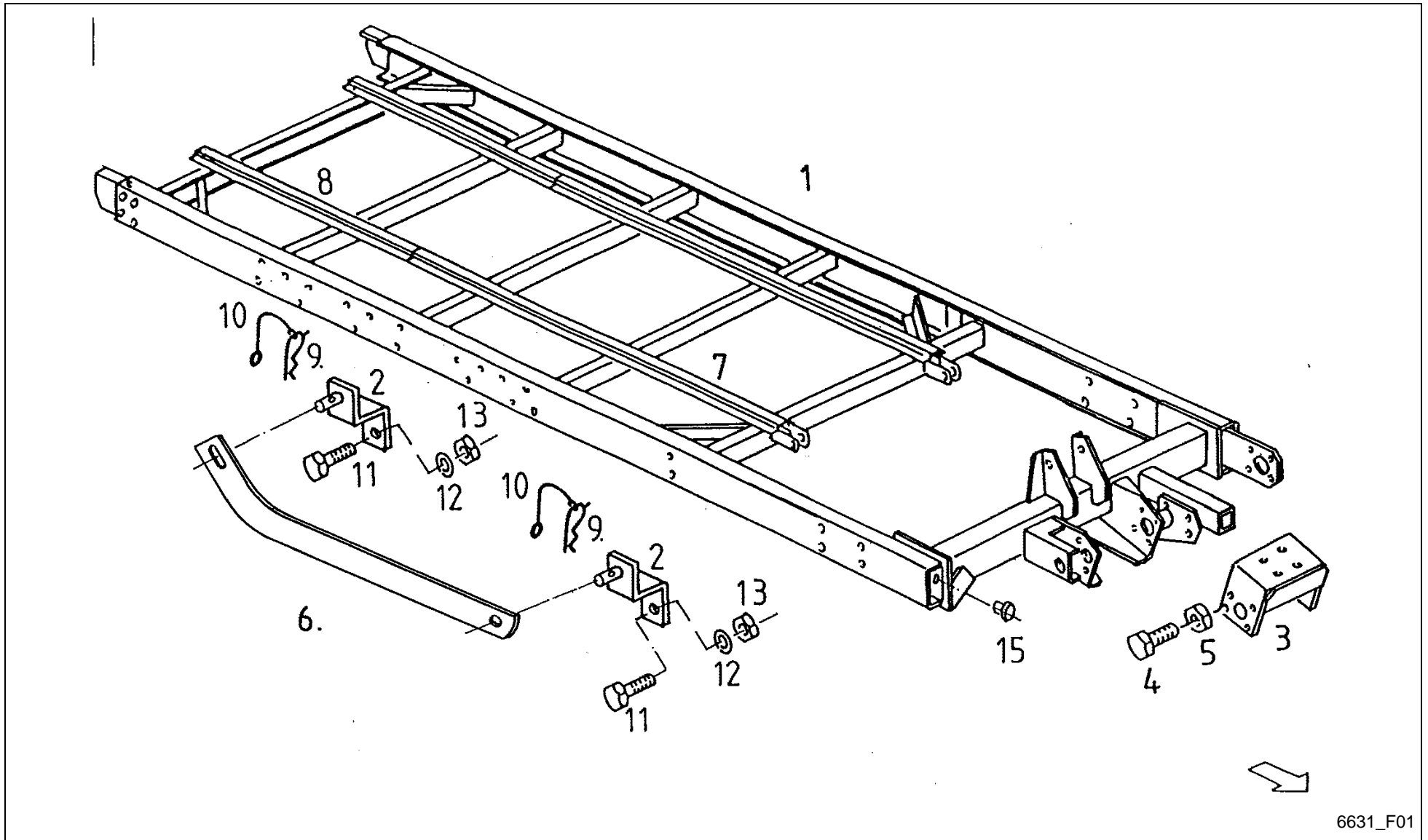

6631_F01

Feedex 360 T / FRAME



PosNo.	Part No.	Qty.	Description	Remark
1	VF16515716	1	CHASSIS FRAME	
2	VF16517171	2	RETAINER	
3	VF06575228	1	BRACKET	
4	VF01112683	4	HEX.HEAD SCHREW	
5	VF01127856	4	LOCK NUT	
6	VF16611366	1	LEVER	
7	VF06572550	2	GUIDE RAIL	
8	VF06558571	2	GUIDE RAIL	
9	VF06264206	2	SPRING	
10	VF06564448	2	CORD L= 240 COLOUR BLACK	
11	VF01112447	2	HEX.HEAD SCREW	
12	VF06214197	2	WASHER 10,5X30X3 GALV.	
13	VF06209768	2	LOCK NUT	
15	VF01001718	1	PLUG GPN300 F19	

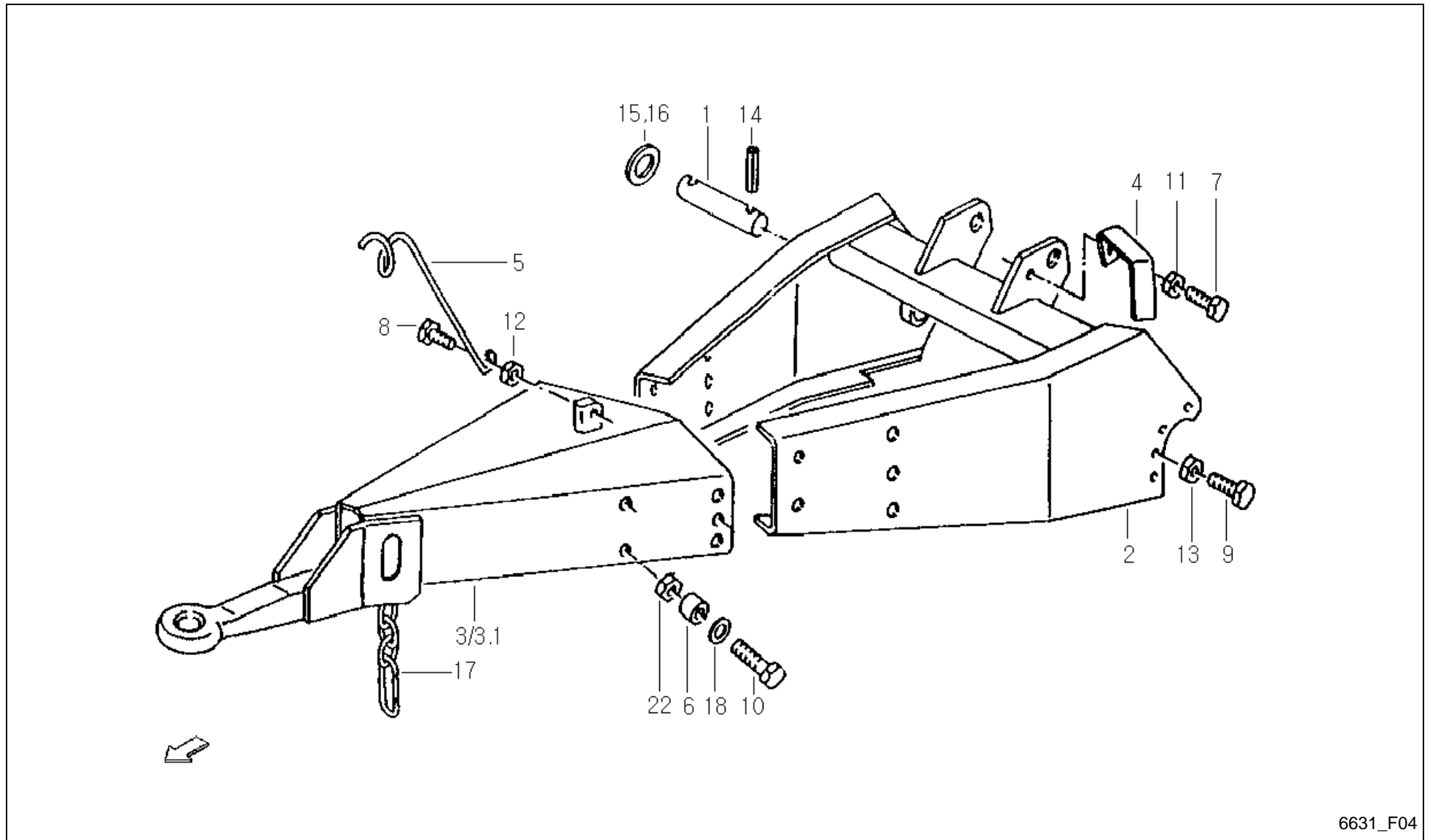

6631_F04

Feedex 360 T / DRAWBAR Z 1040



PosNo.	Part No.	Qty.	Description	Remark
1	VF06554790	1	PIN	
2	VF16631491	1	DEICHSEL GSW.	
3	VF16515251	1	HITCH/PULL ASSY.	bei TA 9t Druckluft (5-loch)
3.1	VF06556268	1	TRACTION BAR	bei EA 6t Druckluft (3-loch)
4	VF16630283	1	CLAMPING PIECE	
5	VF06558567	1	SUPPORT	
6	VF06575227	10	SPACER RING	
7	VF01112333	1	HEX. HEAD SCREW	
8	VF01112418	1	BOLT, SCREW	
9	VF01112687	4	HEX. HEAD SCREW	
10	VF01111867	8	HEX.BOLT	
11	VF01104944	1	NY LOCK NUT 8A3CD985	
12	VF06209768	1	LOCK NUT	
13	VF01127856	4	LOCK NUT	
14	VF01115478	2	DOWEL PIN	
15	VF01137526	2	WASHER	
16	VF06214486	1	SPACER 35X45X1,0 D988	
17	VF16611356	1	CHAIN 4X32 20 LINKS + SNAP HOOK	
18	VF01142556	20	SPACING RING	
19	VF01100590	10	LOCK NUT	

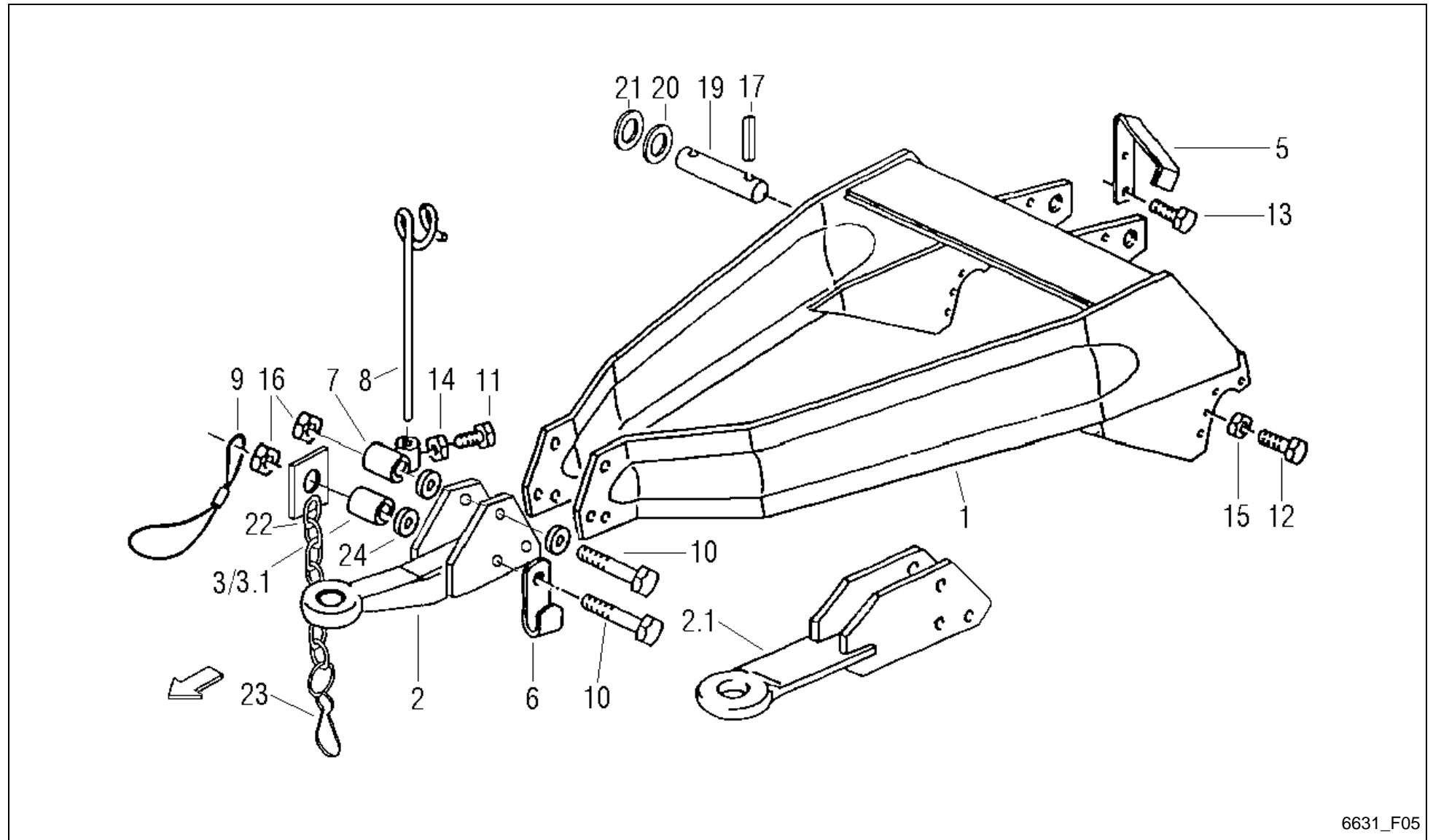

6631_F05

Feedex 360 T / DRAWBAR Z 450



PosNo.	Part No.	Qty.	Description	Remark
1	VF16513246	1	DRAWBAR	
2	VF16631460	1	TRACTION EYE	
2.1	VF16613273	1	DRAWBAR EYE	
3	VF06554525	1	TUBE	
3.1	VF16631478	1	PIPE	bei Pos.2 verwenden
5	VF06558560	1	CLAMPING PIECE	
6	VF06558561	1	ANGLE	
7	VF06558562	1	TUBE	
8	VF06558569	1	SUPPORT	
9	VF06587235	1	SAFETY CABLE	
10	VF01136666	2	HEX. HEAD SCREW	
11	VF01112307	1	HEX. HEAD SCREW	
12	VF01112687	4	HEX. HEAD SCREW	
13	VF06209473	2	BOLT M8X16 D933 8.8 A3C DIN267-27 COATE	
14	VF01112824	1	HEX. NUT	
15	VF01127856	4	LOCK NUT	
16	VF06209774	2	LOCK NUT	
17	VF01115478	2	DOWEL PIN	
19	VF06554790	1	PIN	
20	VF01137526	2	WASHER	
21	VF06214486	1	SPACER 35X45X1,0 D988	
22	VF16611433	1	CHAIN	
23	VF06211876	1	SNAP HOOK C60 D5299 GALV.	
24	VF06214226	3	WASHER	
25	VF01120692	1	GREASE NIPPLE H1 AM 6X1 DIN 71412	

Feedex 360 T / OVERR. DRAWBAR

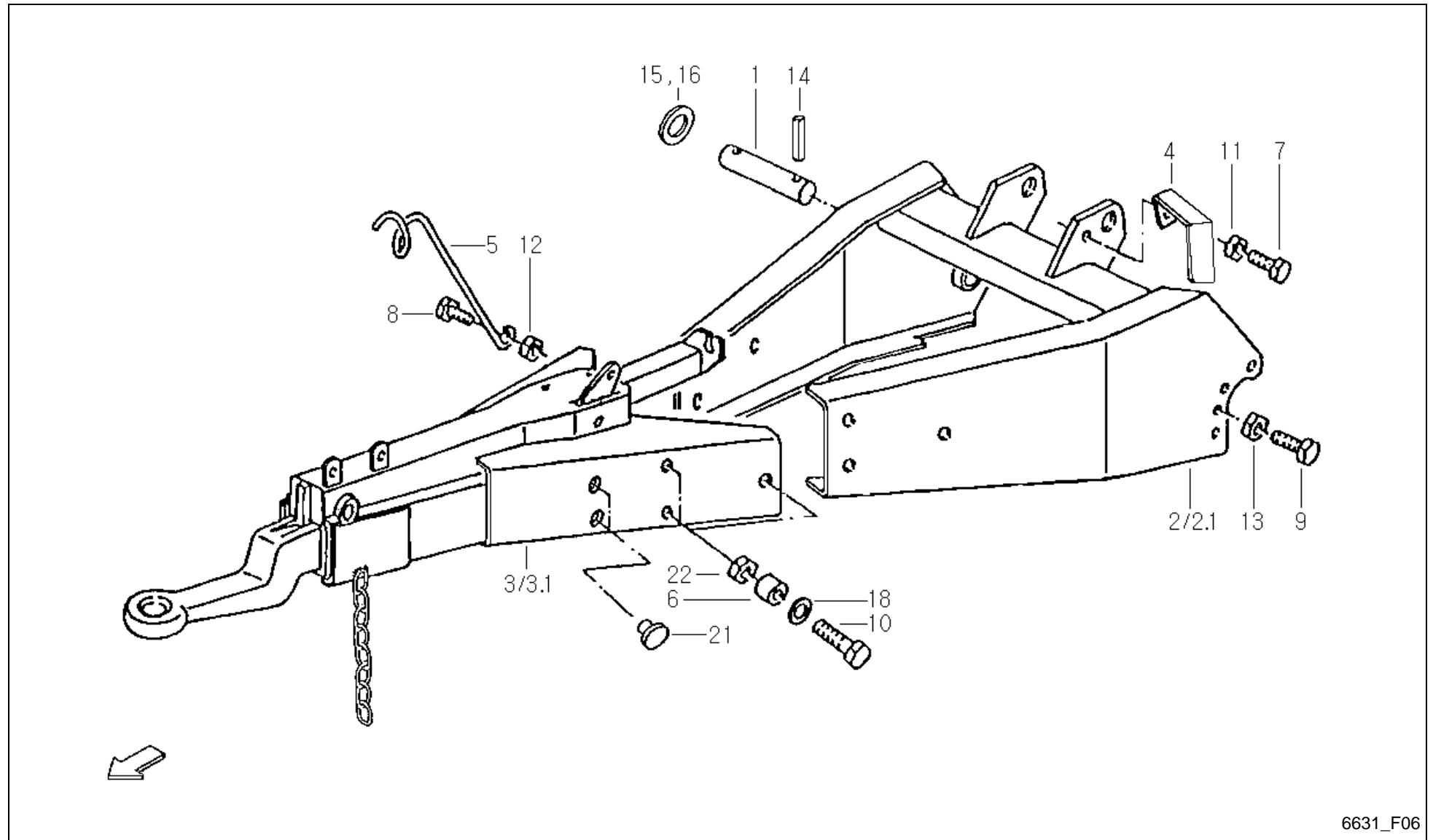

6631_F06



Feedex 360 T / OVERR. DRAWBAR

PosNo.	Part No.	Qty.	Description	Remark
1	VF06554790	1	PIN	
2	VF16517151	1	DRAWBAR	-A 2006
2.1	VF16631491	1	DEICHSEL GSW.	+A 2007
3	VF16613360	1	OVERRUNNING DEVICE	S F07/F08; -700
3.1	VF16630398	1	OVERRUNNING DEVICE	+701
4	VF06558565	1	CLAMPING PIECE	
5	VF06558567	1	SUPPORT	
6	VF06575227	6	SPACER RING	
7	VF01112333	1	HEX. HEAD SCREW	
8	VF01112418	1	BOLT, SCREW	
9	VF01112683	4	HEX.HEAD SCHREW	
10	VF01111867	6	HEX.BOLT	
11	VF01104944	1	NY LOCK NUT 8A3CD985	
12	VF06209768	1	LOCK NUT	
13	VF01127856	4	LOCK NUT	
14	VF01115478	2	DOWEL PIN	
15	VF01137526	1	WASHER	
16	VF06214486	1	SPACER 35X45X1,0 D988	
18	VF01142556	12	SPACING RING	
21	VF01097625	3	PLUG GPN300 F241	
22	VF01100590	6	LOCK NUT	

Feedex 360 T / OVERRUNNING DEVICE (-0700)

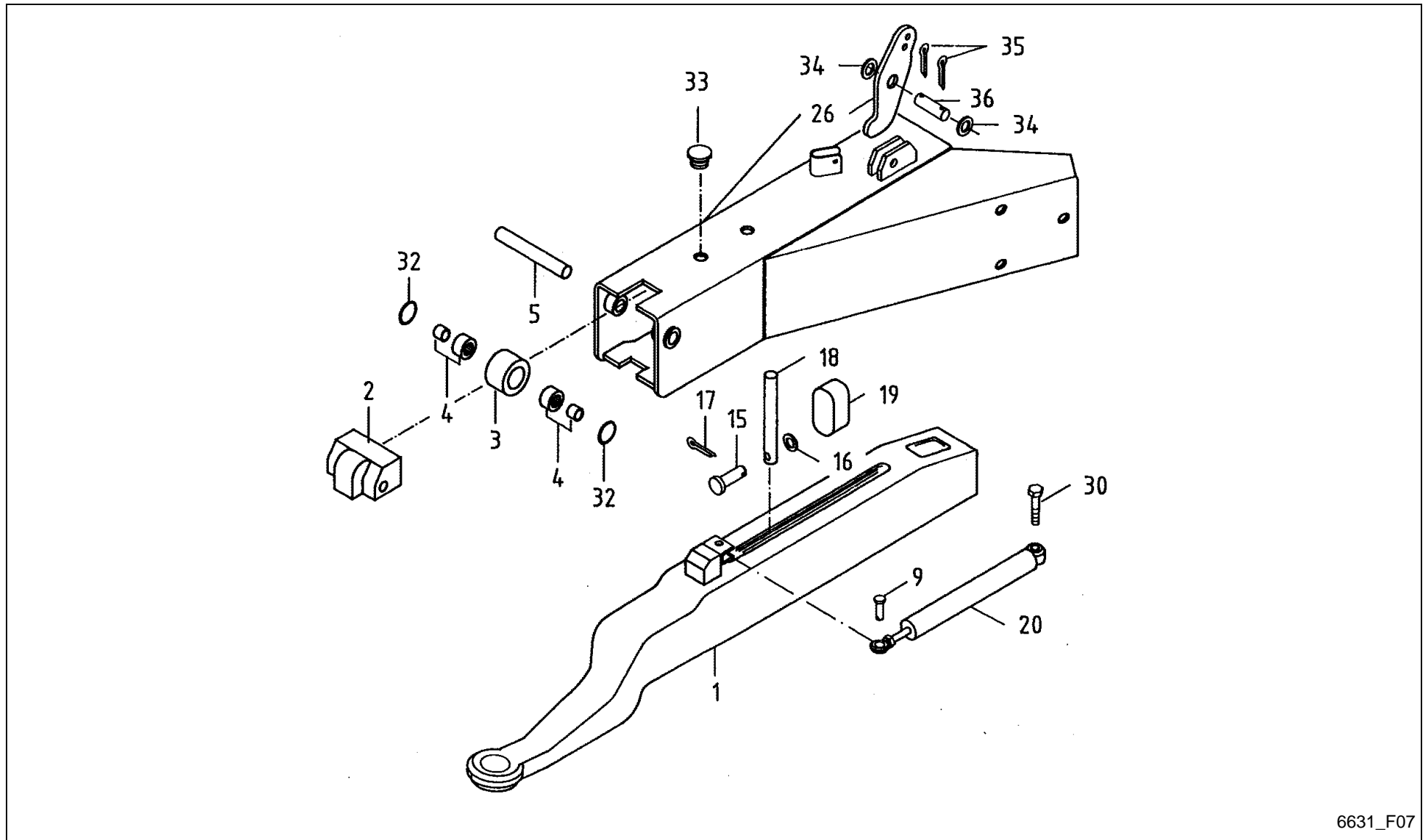

6631_F07



Feedex 360 T / OVERRUNNING DEVICE (-0700)

PosNo.	Part No.	Qty.	Description	Remark
1	VF16614457	1	PULLROD	
2	VF16614458	1	CAP	
3	VF16614459	1	ROLLER	
4	VF16614462	2	NEEDLE SLEEVE	
5	VF16614460	1	PIN	
9	VF16614461	1	PIN	
15	VF06210000	1	PIN	
16	VF01107101	1	WASHER 8,4DIN125 GALV.	
17	KG01248161	1	SPLIT PIN 2X16 ST	
18	VF16614463	1	STOP	
19	VF16614464	1	ABSORBER	
20	VF16614465	1	SHOCK ABSORBER	
26	VF16614469	1	REVERSING LEVER	-700
26	VF16630393	1	REVERSING LEVER	+701
30	VF01111504	1	SCREW	
32	VF16614471	2	RING	
33	VF16614470	2	NIPPLE	
34	VF06214288	2	SPACER	
35	VF01106451	2	SPLIT PIN	
36	VF06209919	1	PIN	

Feedex 360 T / OVERRUNNING DEVICE AVEG 2000 BPW (+0701)

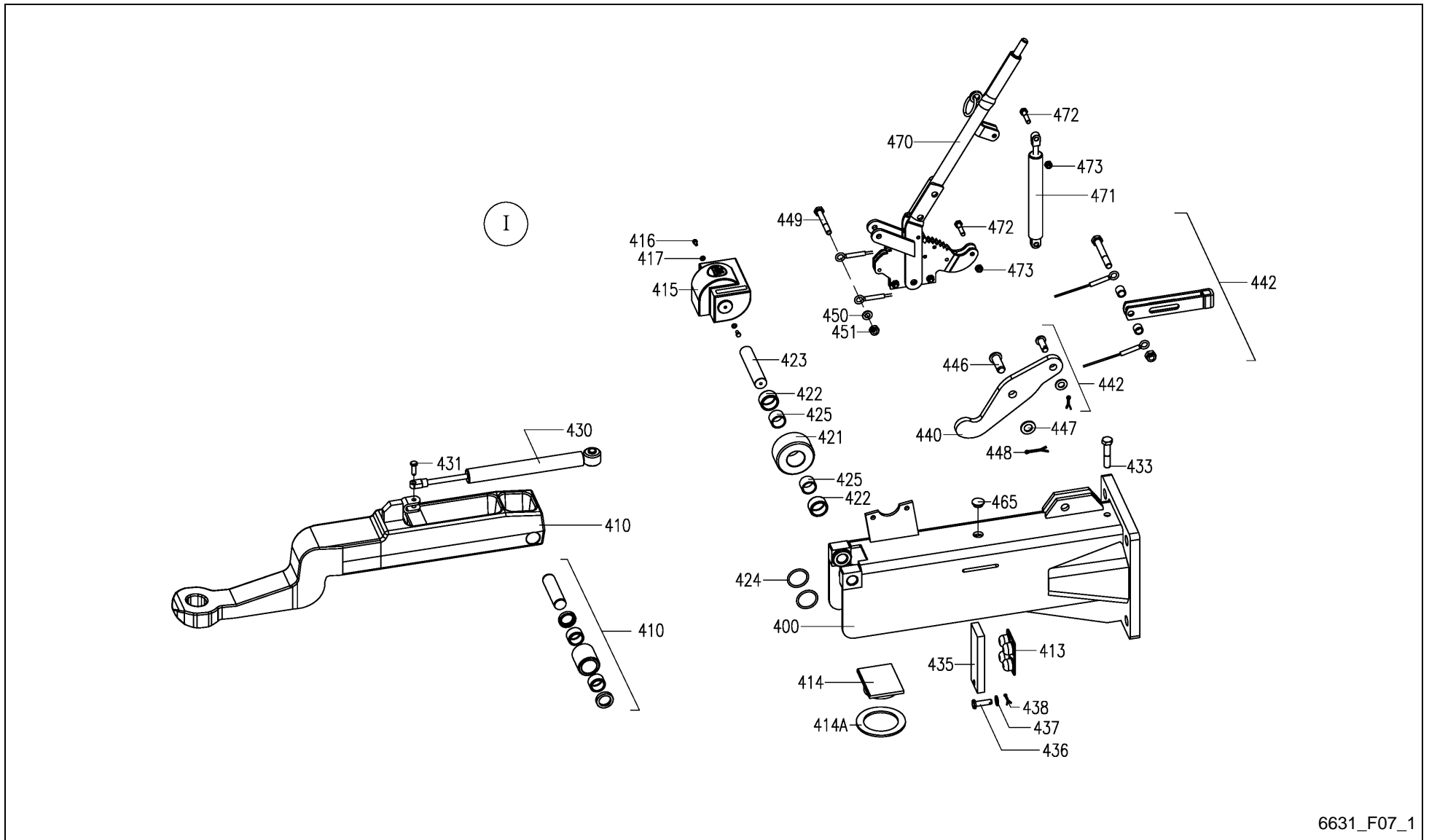

6631_F07_1

Feedex 360 T / OVERRUNNING DEVICE AVEG 2000 BPW (+0701)



PosNo.	Part No.	Qty.	Description	Remark
I	VF16630398	1	OVERRUNNING DEVICE	
400	A143517400	1	HOUSING	
410	VF16614457	1	PULLROD	
413	VF16614464	1	ABSORBER	
414	A143517500	1	PLATE	
414A	A143517600	1	WASHER 100/71X0,5-4,0	
415	VF16614458	1	CAP	
416	A143517700	2	HEXAGON HEAD SCREW M5X10 DIN933 8.8	
417	A143517800	2	WASHER 5,3 DIN125 200 HV	
421	VF16614459	1	ROLLER	
422	A143517900	2	NEEDLE SLEEVE HK3020 DIN618	
423	VF16614460	1	PIN	
424	A143518100	2	O-RING 35X4	
425	A143518200	2	INNER RING 25X30X20,5	
430	VF16614465	1	SHOCK ABSORBER	
431	VF16614461	1	PIN	
433	A143518300	1	HEXAGON HEAD SCREW M12X60 DIN931 8.8	
435	A143518400	1	PLATE	
436	A143518500	1	BOLT 10X35X31 DIN1434 ST	
437	A143466900	1	WASHER 10,5 DIN125 200HV	
438	A143485300	1	SPLIT PIN 3,2X16 ISO1234	
440	A143518600	1	DEFLEXION LEVER 120:85	
442	A143518700	1	BRAKE CABLE, COMPLETE	
446	A143518800	1	BOLT 16X45X38 DIN1434 ST	
447	A143518900	1	WASHER 17 DIN125 200 HV	
448	A143472600	1	SPLIT PIN 4X25 ISO1234	
449	A143519000	1	HEXAGON HEAD SCREW M10X75 DIN931 8.8	
450	A143466900	1	WASHER 10,5 DIN125 200HV	
451	A143467500	1	LOCK NUT VM10 DIN980	
465	VF16624942	1	PLUG	
470	A143519100	1	HAND BRAKE LEVER	
471	A143519200	1	DAMPER	
472	A143518000	2	HEXAGON HEAD SCREW M8X35 DIN933 8.8	
473	A143517100	2	LOCK NUT VM8 DIN980	

Feedex 360 T / OVERRUN BRAKE BRAKE LEVER (-0700)

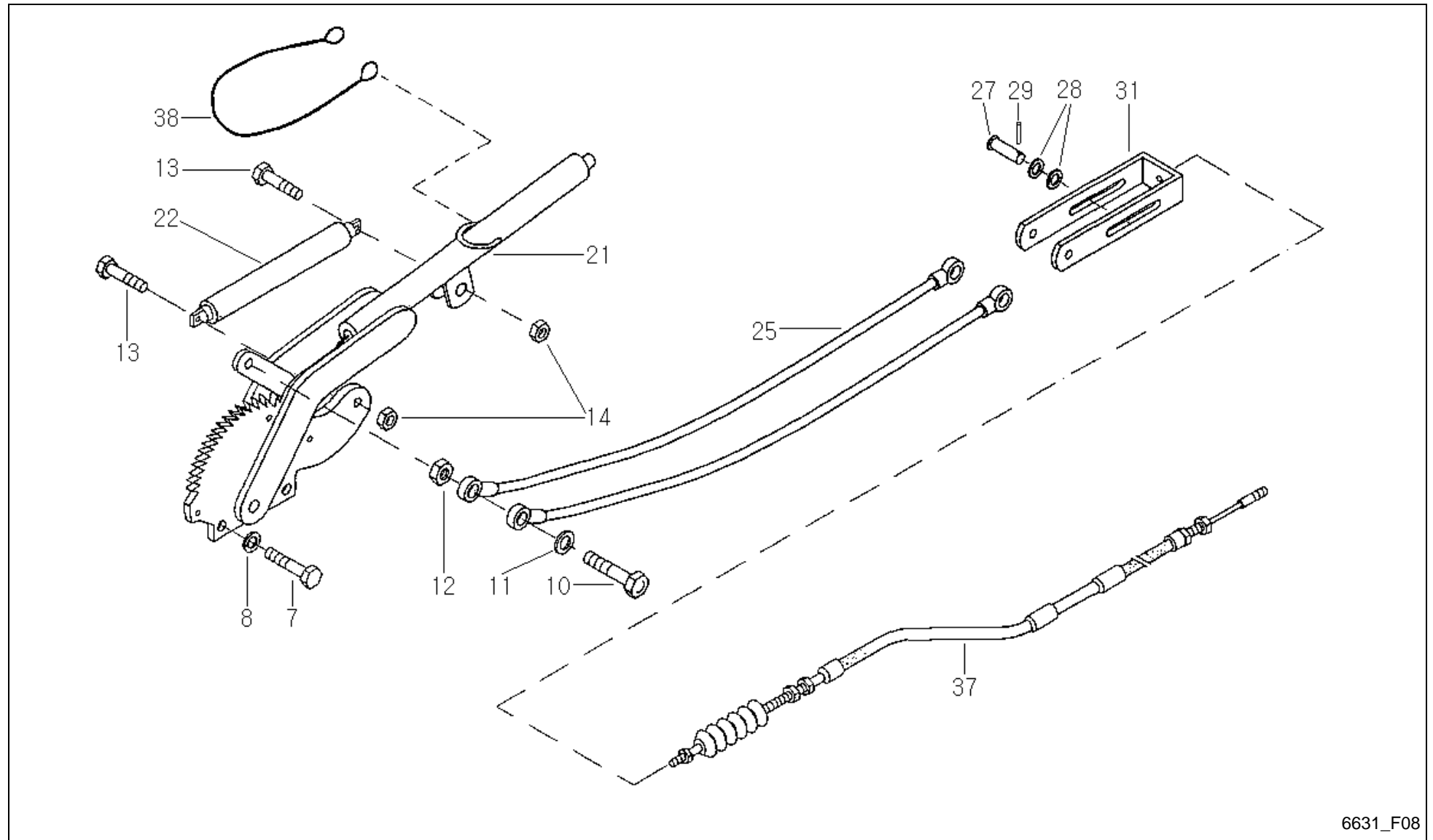

6631_F08

Feedex 360 T / OVERRUN BRAKE BRAKE LEVER (-0700)



PosNo.	Part No.	Qty.	Description	Remark
7	VF01112333	2	HEX. HEAD SCREW	
8	VF01102799	2	SPRING WASHER	
10	VF01111336	1	HEX.HEAD SCREW	
11	VF01107105	1	WASHER	
12	VF01102659	1	HEX. NUT	
13	VF01112350	2	HEX. HEAD SCREW	
14	VF01112824	2	HEX. NUT	
21	VF16614466	1	HAND BRAKE LEVER	
22	VF16614467	1	GAS-FILLED DAMPFER	
25	VF16614468	1	BRAKE CABLE	
27	VF06210015	1	PIN	
28	VF06214207	2	WASHER	
29	VF01106451	1	SPLIT PIN	
31	VF16614456	1	FORK	
37	VF06556619	1	BRAKE CABLE	
38	VF06587227	1	FIXING ROPE	

Feedex 360 T / ADJUSTING SPINDLE

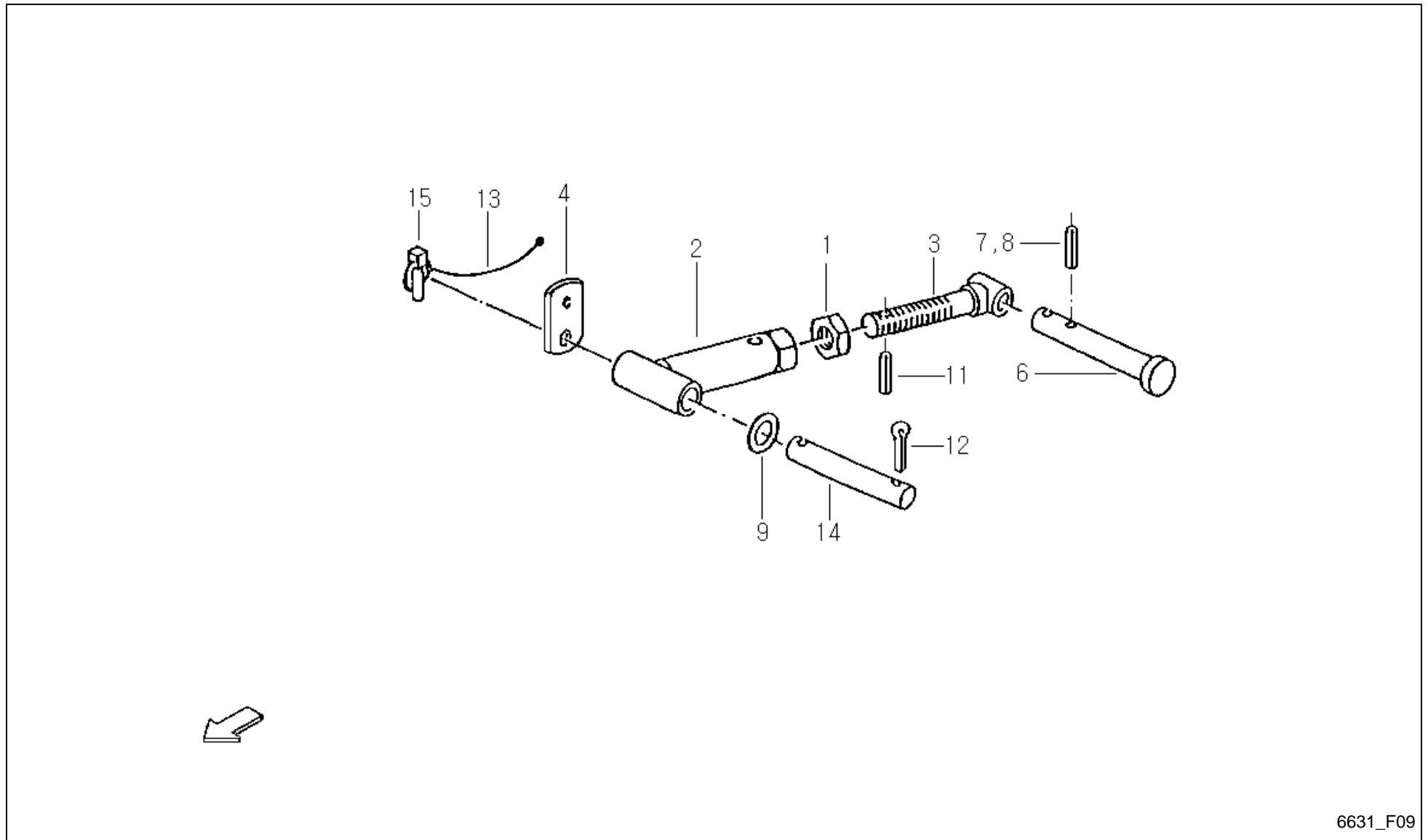

6631_F09



Feedex 360 T / ADJUSTING SPINDLE

PosNo.	Part No.	Qty.	Description	Remark
1	VF01112972	1	HEX.NUT	
2	VF16517160	1	SPINDLE	
3	VF16517144	1	THREADED SPINDLE	
4	VF16517165	1	CONNECTING PLATE	
6	VF16515159	1	PIN/BOLT/STUD	S D20 Pos. 15
7	VF01136930	1	DOWEL PIN	
8	VF01157345	1	DOWEL PIN	
9	VF06214238	1	WASHER 34X50X5 A2C DIN 1441	
11	VF01115438	1	DOWEL PIN	
12	VF01106500	1	SPLIT PIN 8X50DIN94 GALV.	
13	VF06564448	1	CORD L= 240 COLOUR BLACK	
14	VF01397597	1	PIN/BOLT/STUD	
15	VF06213664	1	FOLDING PLUG	

Feedex 360 T / ELECTR.REMOTE CONTR. PILOTBOX-T

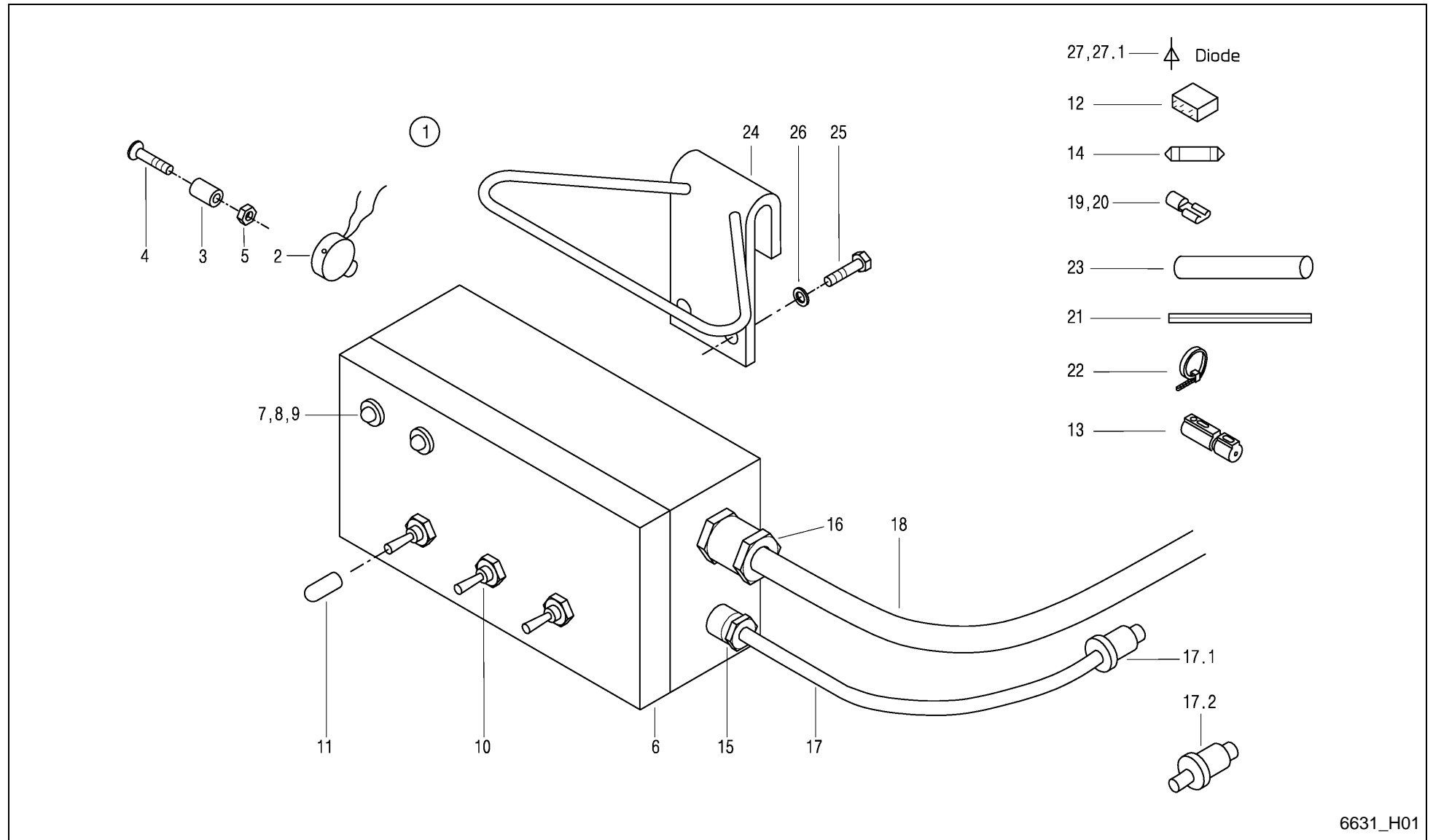

6631_H01

Feedex 360 T / ELECTR.REMOTE CONTR. PILOTBOX-T



PosNo.	Part No.	Qty.	Description	Remark
1	VF16613394	1	PILOTBOX-T	
2	VF06579959	1	HORN	
3	VF06579960	2	SLEEVE	
4	VF01397550	2	C'SUNK SCREW	
5	VF01143097	2	HEX.NUT	
6	VF16613387	1	HOUSING/CASE	
7	VF16613236	1	RED LAMP	
8	VF16613237	1	GREEN LAMP	
9	VF16613238	2	O-RING	
10	VF06579979	3	TOGGLE SWITCH	
11	VF16515453	3	CAP	
12	VF01164017	1	RELAY	
13	VF06587052	1	SUPPORT	
14	VF01143017	1	FUSE	
15	VF06213737	1	UNION	
16	VF01151892	1	THREADED UNION	
17	VF06579961	1	CABLE	mit Pos.17.1
17.1	VF01101600	1	PLUG	
17.2	VF16518524	1	PLUG CONTACT 3-POLE BIS 25A DIN 9680	alternativ
18	VF01142889	1	ELECTRIC LINES	
19	VF01397896	13	PLUG-IN SLEEVE	
20	VF01397920	15	PLUG-IN SLEEVE	
21	VF01403239	1	ELECTRIC LINES	
22	VF06216479	3	CABLE TIE 150X3,6 SW SNX 2-35	
23	VF16513942	1	SHRINK HOSE	
24	VF16515468	1	YOKE/RETAINER	
25	VF01112240	2	HEX. HEAD SCREW	
26	VF01118645	2	SEAL RING	
27	VF16511469	5	DIODE	
27.1	VF16513933	1	DIODE	+451

Feedex 360 T / ELECTR. EGUIPM. DISTRIBUTION BOX

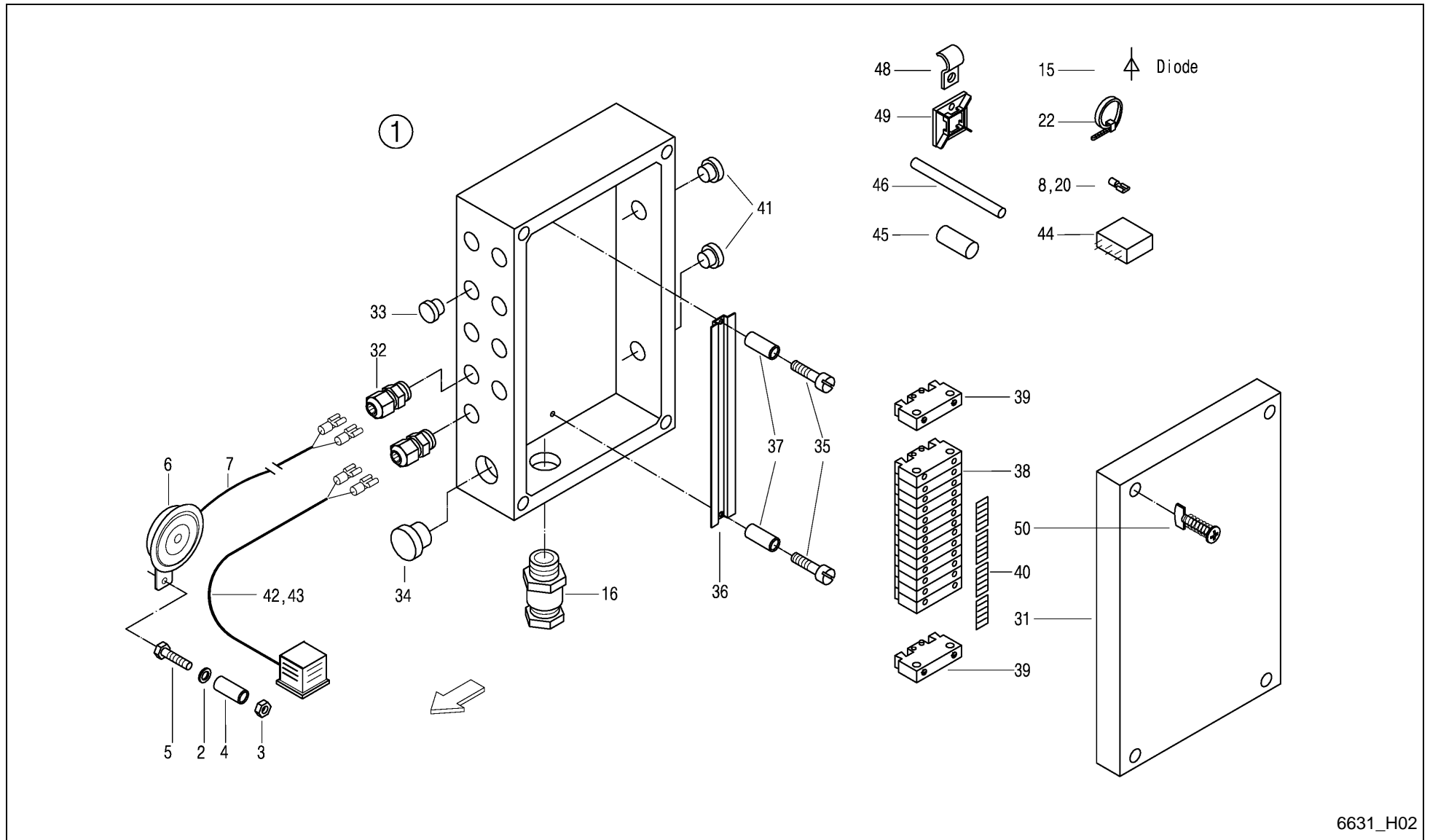

6631_H02



Feedex 360 T / ELECTR. EGUIPM. DISTRIBUTION BOX

PosNo.	Part No.	Qty.	Description	Remark
1	VF16613396	1	DISTRIBUTION BOX	
2	VF01107163	2	WASHER	-A 2005
3	VF01104944	1	NY LOCK NUT 8A3CD985	-A 2005
4	VF16606570	1	FIXING TUBE GALV. L=48 RO.16X2.5	-A 2005
5	VF01111179	1	HEX.BOLD	-A 2005
6	VF06214045	1	HORN	-A 2005
7	VF16611480	1	CABLE	-A 2005
8	VF01397896	2	PLUG-IN SLEEVE	
15	VF16511469	5	DIODE	
16	VF01151892	1	THREADED UNION	
20	VF01397920	17	PLUG-IN SLEEVE	
22	VF06216479	13	CABLE TIE 150X3,6 SW SNX 2-35	
31	VF16517792	1	HOUSING	
31.1	VF16611275	4	QUICK FASTENER	
32	VF02953409	6	THREADED UNION	
33	VF01397704	4	BLANK PLUG	
34	VF02953408	1	BLANK PLUG	
35	VF01105571	2	CHEESE-HEAD SCREW	
36	VF16517922	1	SUPPORT RAIL	
37	VF16517923	2	SLEEVE	
38	VF16515446	14	TERMINAL	
39	VF16515448	2	END HOLDER	
40	VF16517917	1	LETTERING	
41	VF02953410	2	NIPPLE	
42	VF16518970	4	PIPE/LINE/LEAD	
42	VF01128192	6	CABLE END SOCKET	
42.1	VF06579981	3	TIN	
42.2	VF06579982	3	SECTIONAL SEAL	
43.3	VF16611079	3	INSCRIPTION PLATE	
44	VF16613243	1	RELAY	
45	VF16611081	1	SHRINK HOSE	
46	VF01404321	2	SHRINK HOSE	
48	VF06216397	2	FIXING CLIP	
49	VF16613283	2	CABLE RETAINER	
50	VF01397598	2	SELF-TAPPING SCREW	

Feedex 360 T / ELECTR. EQUIPM. LIGHTING

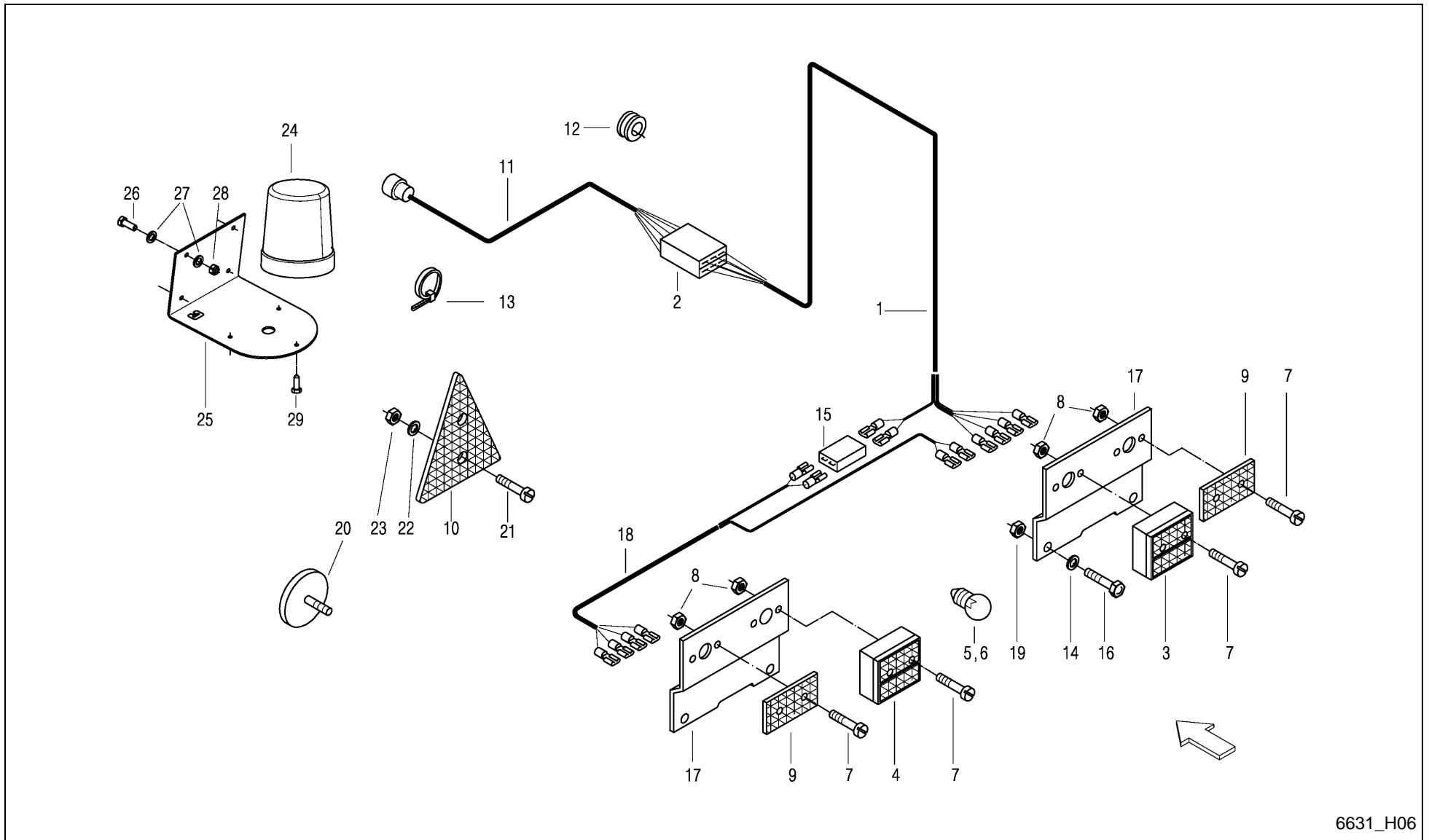

6631_H06

Feedex 360 T / ELECTR. EQUIPM. LIGHTING



PosNo.	Part No.	Qty.	Description	Remark
1	VF16516330	1	ELECTRIC LINES	
2	VF06213977	1	CABLE CONNECTOR	
3	VF01397870	1	TAIL LIGHT	
4	VF01397871	1	TAIL LIGHT	
5	VF01102550	2	TABULAR LAMP12V 21W D72601	
6	VF01135950	2	BULB	
7	VF01105524	8	CHEESE HEAD SCREW	
8	VF06209765	8	LOCK NUT M5 8 GALV. DIN985	
9	VF04308511	2	REAR REFLECTOR	
10	VF16631249	2	TRIANGLE REAR REFLECTOR	
11	VF06577068	1	CABLE	
12	VF06278838	1	RUBBER GROMMET	
13	VF06216479	35	CABLE TIE 150X3,6 SW SNX 2-35	
14	VF01102797	4	SPRING WASHER	
15	VF06213973	1	CONNECTING PIECE	
16	VF01103316	4	HEX. HEAD SCREW	
17	VF16515977	2	LIGHT RETAINER	
18	VF16516333	1	ELECTRIC LINES	
19	VF01114357	4	LOCK NUT	
20	VF06214041	2	REFLECTOR WHITE D80 WITH HOLE 5.5	
21	VF01105526	4	CYL. SCREW AM 5X16 DIN 84 - A3C -4.8	
22	VF01102796	4	SPRING WASHER	
23	VF01112803	4	HEX. NUT M5	
24	VF16635245	1	BEACON	Option Rundumkennleuchte
25	VF16635247	1	ANGLE PLATE,	Option Rundumkennleuchte
26	VF01112264	4	HEX. HEAD SCREW	Option Rundumkennleuchte
27	VF06214189	8	WASHER 6,4X18X2 A2C	Option Rundumkennleuchte
28	VF01114357	4	LOCK NUT	Option Rundumkennleuchte
29	VF16635249	3	SCREW 4.8X16	Option Rundumkennleuchte

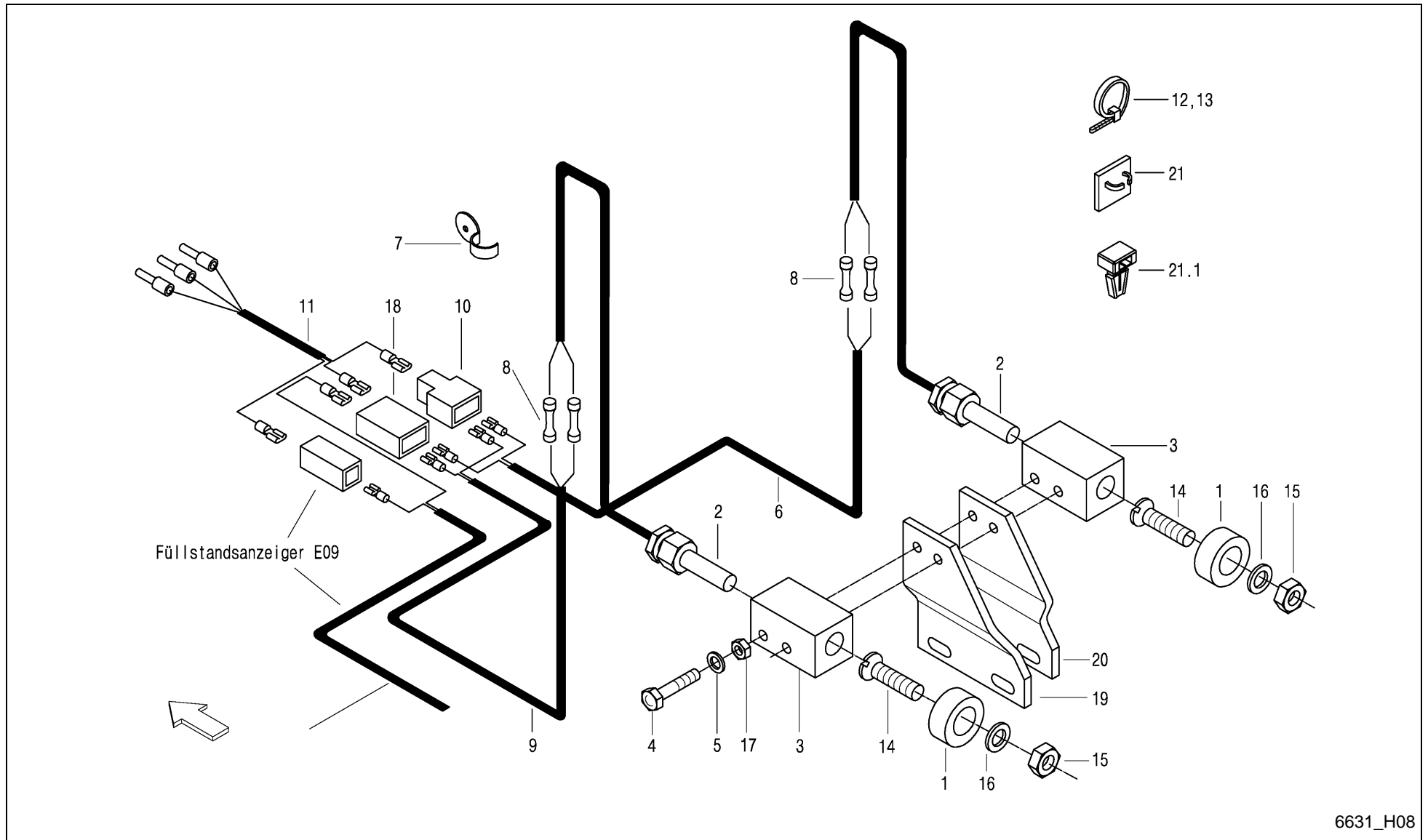

6631_H08

Feedex 360 T / ELECTR. EQUIPM. BACK NET



PosNo.	Part No.	Qty.	Description	Remark
1	VF16512287	2	MAGNET	
2	VF16514460	2	SWITCH	
3	VF16517215	2	SWITCH HOUSING	
4	VF01111071	4	HEX. HEAD SCREW	
5	VF01107095	4	WASHER 6,4DIN125 GALV.	
6	VF16516335	1	ELECTRIC LINES	
7	VF06216396	4	HOSE CLIP	
8	VF01397855	4	CONNECTOR/UNION	
9	VF16516337	1	ELECTRIC LINES	
10	VF06213974	1	PLUG CONNECTION	
11	VF16515739	1	ELECTRIC LINES	
12	VF06216479	6	CABLE TIE 150X3,6 SW SNX 2-35	
13	VF06216480	2	CABLE TIE 368X4,8 SW SNX 3-100	
14	VF01132294	2	SCR. M5X25 D963 48 GALV.	
15	VF06209765	2	LOCK NUT M5 8 GALV. DIN985	
16	VF01107158	2	WASHER	
17	VF01114357	4	LOCK NUT	
18	VF06213982	1	CLUTCH PIECE	
19	VF16611318	1	BASE PLATE	
20	VF16611317	1	BASE PLATE	
21	VF16613283	6	CABLE RETAINER	-A 2004
21.1	VF16631248	6	EXPANSION ANCHOR	+A 2005

Feedex 360 T / PICK-UP 1.6 SCRAPER

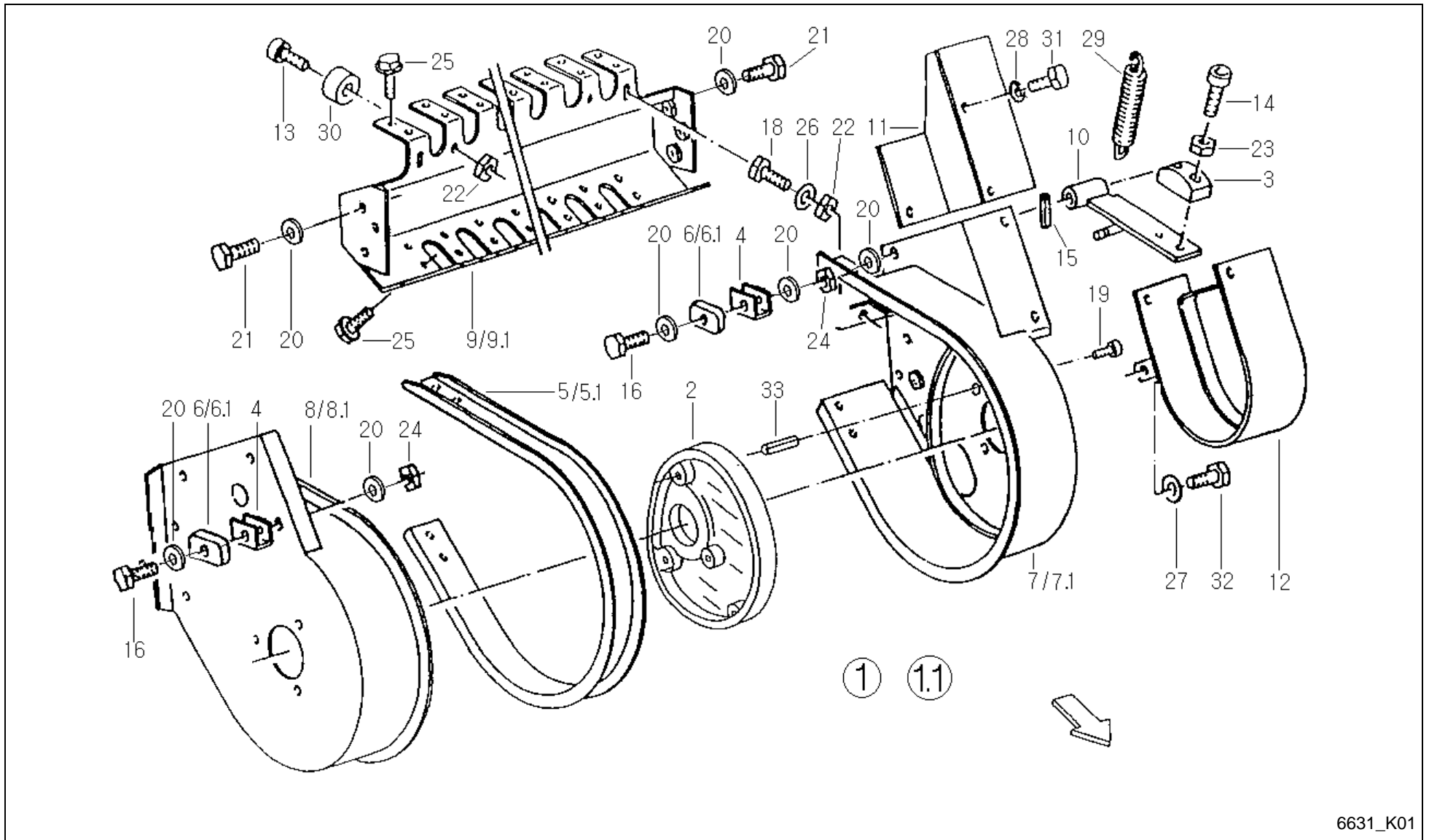

6631_K01



Feedex 360 T / PICK-UP 1.6 SCRAPER

PosNo.	Part No.	Qty.	Description	Remark
1	VF16513250	1	PICK-UP	-540
1.1	VF16630125	1	PICK-UP 5 REEL	+541
2	VF06296264	1	STEERING PLATE	
3	VF06571134	1	TENSION-BLOCK	X 10
4	VF06571322	3	YOKE	
5	VF06577405	25	SHEET	-540
5.1	VF16630114	25	SCRAPER	+541
6	VF06571323	6	STOP	
6.1	VF16635132	1	LIMIT STOP	+A 2012
7	VF06571005	1	SIDE PART	-540
7.1	VF16630115	1	SIDE PLATE LEFT	+541
8	VF06577426	1	SIDE MEMBER	-540
8.1	VF16630119	1	SIDE PLATE RIGHT	+541
9	VF06570920	1	SUPPORT	-540
9.1	VF16630112	1	SUPPORT	+541
10	VF06571094	1	CHAIN TENSIONER	
11	VF06571099	1	GUARD PLATE	
12	VF06571090	1	CHAIN/TRACK GUARD	
13	VF01105544	2	CYLINDRICAL SCREW	
14	VF01110577	2	SCREW	X 10
15	VF01115441	1	DOWEL PIN	
16	VF01111298	3	HEX. HEAD SCREW	
18	VF01112264	2	HEX. HEAD SCREW	
19	VF06209476	2	BOLT M8X30 D933 8.8 A3C DIN267-27 COATE	
20	VF01107165	12	WASHER M10 11X20X2 A2C DIN126	
21	VF01112418	6	BOLT, SCREW	
22	VF01114357	4	LOCK NUT	
23	VF01104944	2	NY LOCK NUT 8A3CD985	X 10
24	VF06209768	2	LOCK NUT	
25	VF0905191000	106	GEWINDEFURCHSCHRAUBE M 6 X 16	
26	VF06214189	4	WASHER 6,4X18X2 A2C	
27	VF01107163	1	WASHER	
28	VF01102799	3	SPRING WASHER	
29	VF06215561	1	TENSION SPRING	
30	VF06571355	2	RUBBER BLOCK	
31	VF01112322	3	HEX. HEAD SCREW	
32	VF01112307	1	HEX. HEAD SCREW	
33	VF16614668	1	PIN, TENSION	

Feedex 360 T / PICK-UP 1.6 DRUM

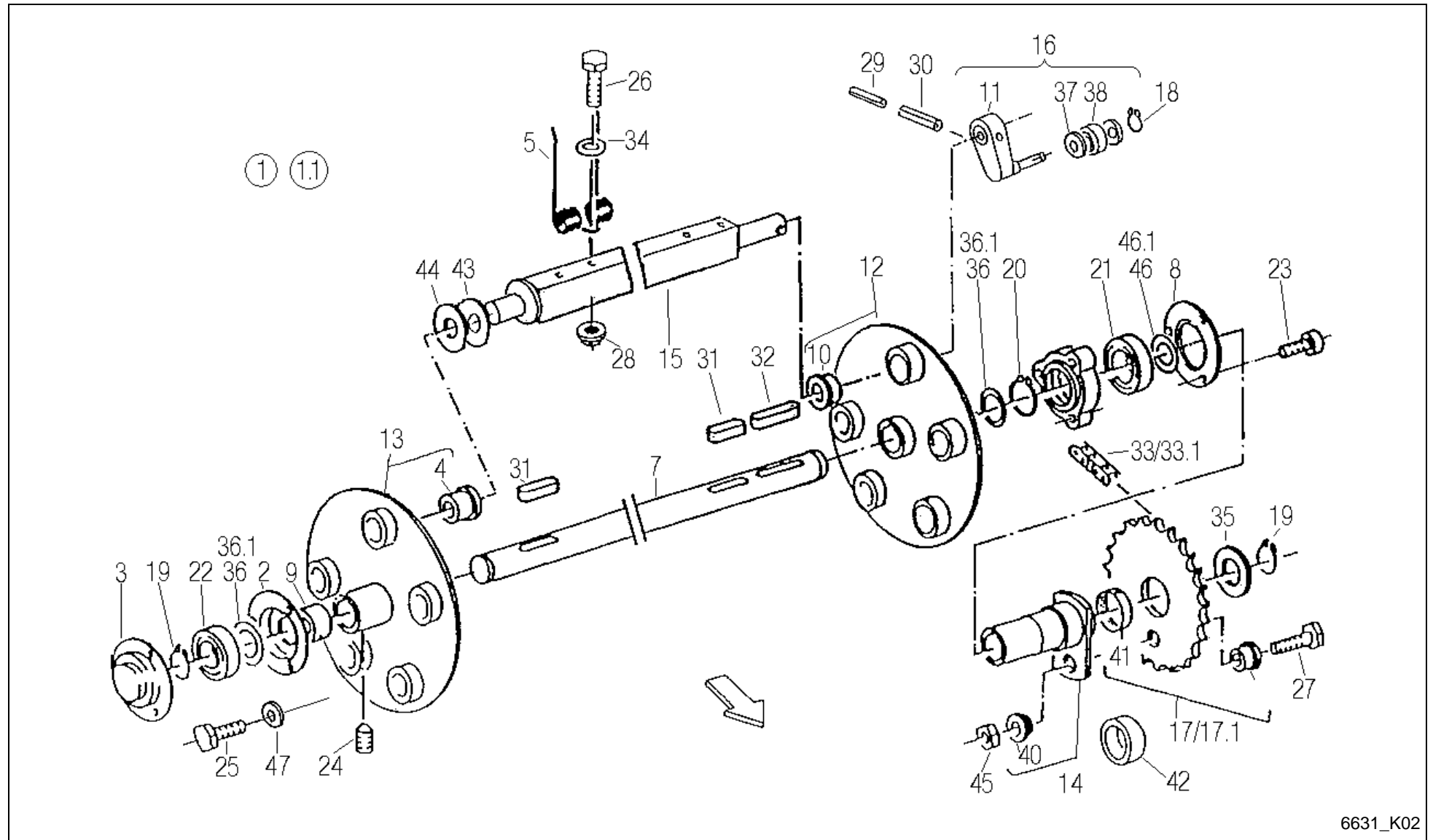

6631_K02



Feedex 360 T / PICK-UP 1.6 DRUM

PosNo.	Part No.	Qty.	Description	Remark
1	VF16513250	1	PICK-UP	-540
1.1	VF16630125	1	PICK-UP 5 REEL	+541
2	VF06282196	1	TERMINAL RING	
3	VF06301830	1	TERMINAL RING	
4	VF06246795	5	BUSH	
5	VF06296285	65	PICK-UP TINE, TWIN	
6	VF06577397	1	FLANGE	
7	VF06571004	1	DRIVE SHAFT	
8	VF06577406	1	COVER	
9	VF06577407	1	SPACER RING	
10	VF06571309	5	BUSH	
11	VF06571321	5	PIN	
12	VF16513298	1	ROSETTE	
13	VF16513299	1	ROSETTE	
14	VF06559244	1	FLANGED HUB	
15	VF16613400	5	TUBE	
16	VF16615203	5	CONTROL ARM	
17	VF16630156	1	CHAIN SPROCKET Z=34	-A 2005
17.1	VF06577432	1	CHAIN SPROCKET	+A 2006
18	VF01107726	5	CIRCLIP	
19	VF01107742	2	CIRCLIP	
20	VF01107760	1	CIRCLIP	
21	VF01108982	1	GR.BALL BEARING	
22	VF01136763	1	GR. BALL BEARING	
23	VF02953340	3	BOLT M8X50 D912 DIN267-27 COATED	
24	VF06208913	2	ALLEN SET SCREW, INT. HEX.	
25	VF01173381	3	SCR.M8X20 D933 8.8 GALV.DIN267-27MKL	
26	VF01111184	65	HEX.BOLT	
27	VF16630966	1	SHEAR SCREW	
28	VF01397863	65	WHEEL NUT M8 D6926 8 GALV.	
29	VF01157348	5	DOWEL PIN	
30	VF01157382	5	ROLL PIN 10X65 EN ISO 8752 ZN.FL.	
31	VF06212426	2	FITTING KEY	
32	VF06212435	1	FITTING KEY	
33	VF16630139	1	CHAIN 19.05-12B-1X87GL. D8187	bei Pos.17
33.1	A143015000	1	CHAIN 12B-1VX86E INCL. VGL	bei Pos.17.1
34	VF01138374	65	WASHER	
35	VF06214420	1	DISC	
36	VF06214481		SPACER 30X42X1 DIN988	
36.1	VF01138686		SPACER 30X42X0,5 DIN988	

Feedex 360 T / PICK-UP 1.6 DRUM

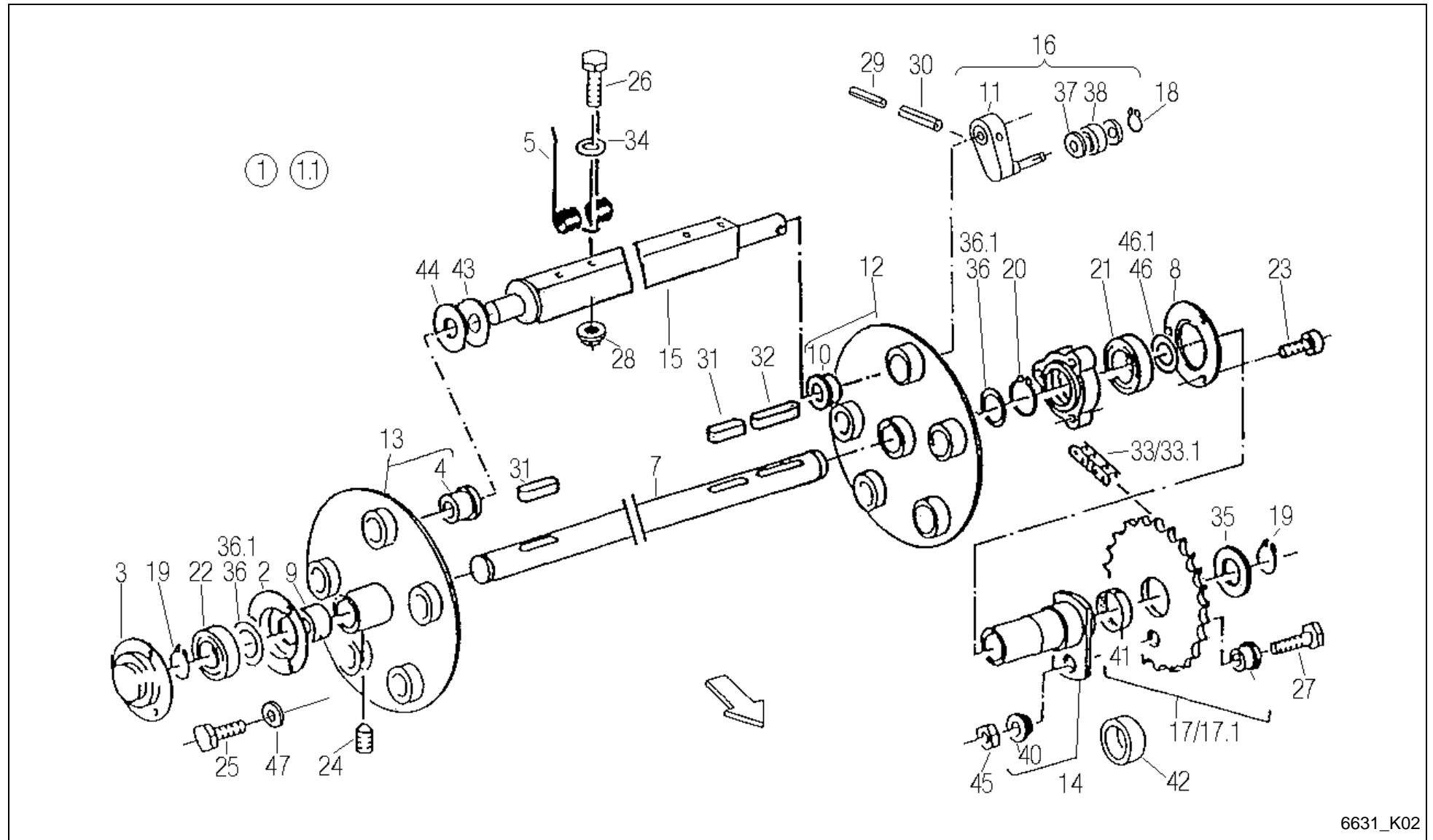

6631_K02

Feedex 360 T / PICK-UP 1.6 DRUM



PosNo.	Part No.	Qty.	Description	Remark
37	VF06214938	10	NILOSRING 6303 ZAV	
38	VF06215027	5	LAUFROLLE LR 203NPPU 17X47X12	
40	VF06571314	2	BUSH	
41	VF06277516	1	BEARING BUSH	
42	VF06571148	1	PIPE/TUBE	
43	VF06214314	5	WASHER 26X38X1 GALV.	
44	VF06214313	5	WASHER 26X38X2 GALV.	
45	VF01104944	1	NY LOCK NUT 8A3CD985	
46	VF06214570		SPACER	
46.1	VF06214572		SPACER 45X55X0,5	
47	VF16631181	3	WASHER A8	

Feedex 360 T / PICK-UP 1.6 BAFFLE PLATE

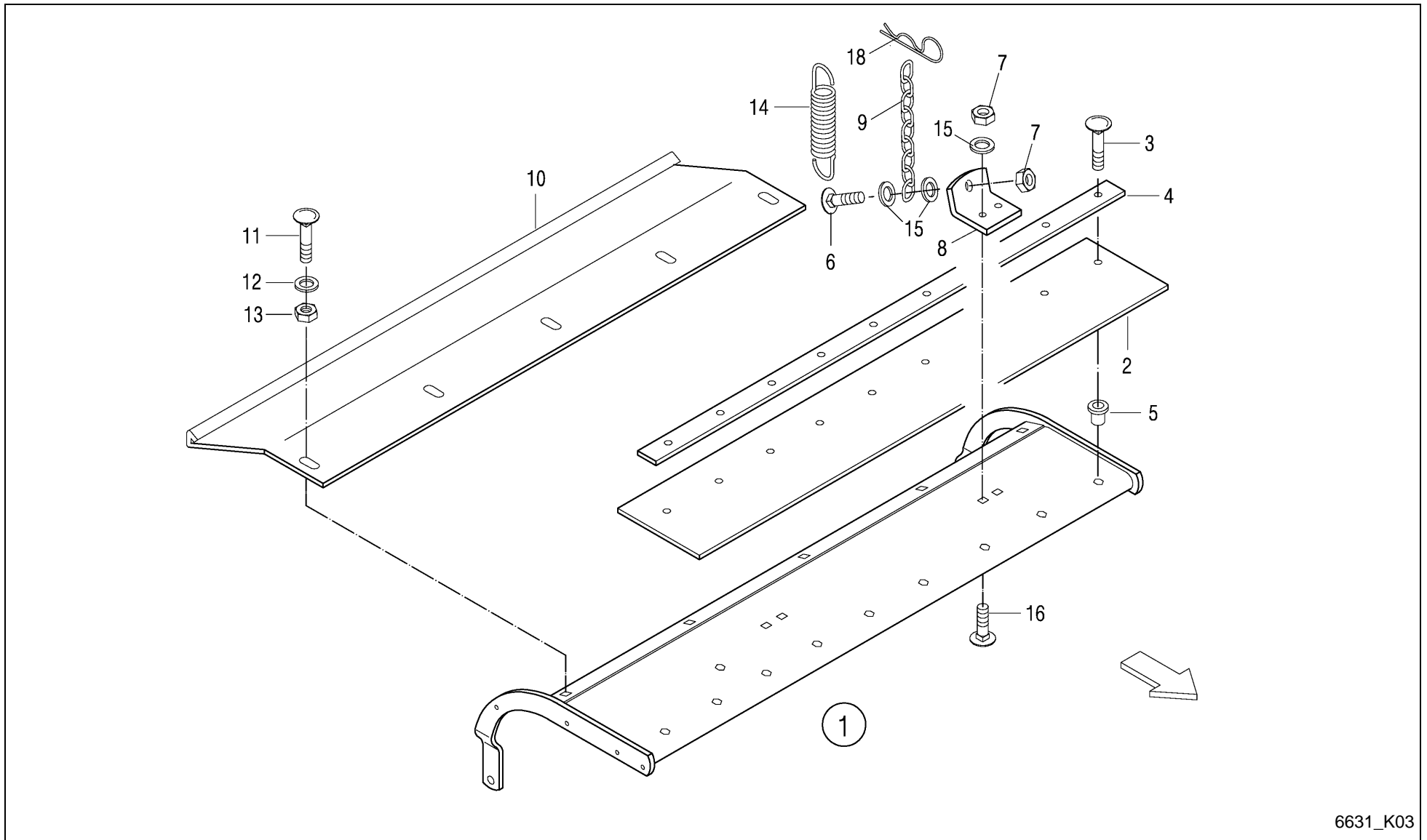

6631_K03



Feedex 360 T / PICK-UP 1.6 BAFFLE PLATE

PosNo.	Part No.	Qty.	Description	Remark
1	VF16611487	1	BAFFELE-PLATE	
2	VF16611479	1	RUBBER BAR	X 1
3	VF01142806	9	TRUSS-HEAD SCREW	X 1
4	VF06578934	1	STRIP	X 1
5	VF01142805	9	RIVET NUT	X 1
6	VF01137628	2	SAUCER HEAD SCREW	
7	VF01104944	6	NY LOCK NUT 8A3CD985	X 1
8	VF16513473	2	RETAINER	X 1
9	VF01397609	2	CHAIN/TRACK	
10	VF06577423	1	EXTENSION	
11	VF06207535	5	OVAL HEADED BOLT	
12	VF01107165	5	WASHER M10 11X20X2 A2C DIN126	
13	VF01104944	5	NY LOCK NUT 8A3CD985	
14	VF01397931	2	DRAW SPRING	
15	VF01127538	4	WASHER	
16	VF01108524	4	SCREW	X 1
18	VF06215666	2	SPRING CLIP	

Feedex 360 T / PICK-UP 1.6 TACTILE WHEEL PNEUMATIC TIRE

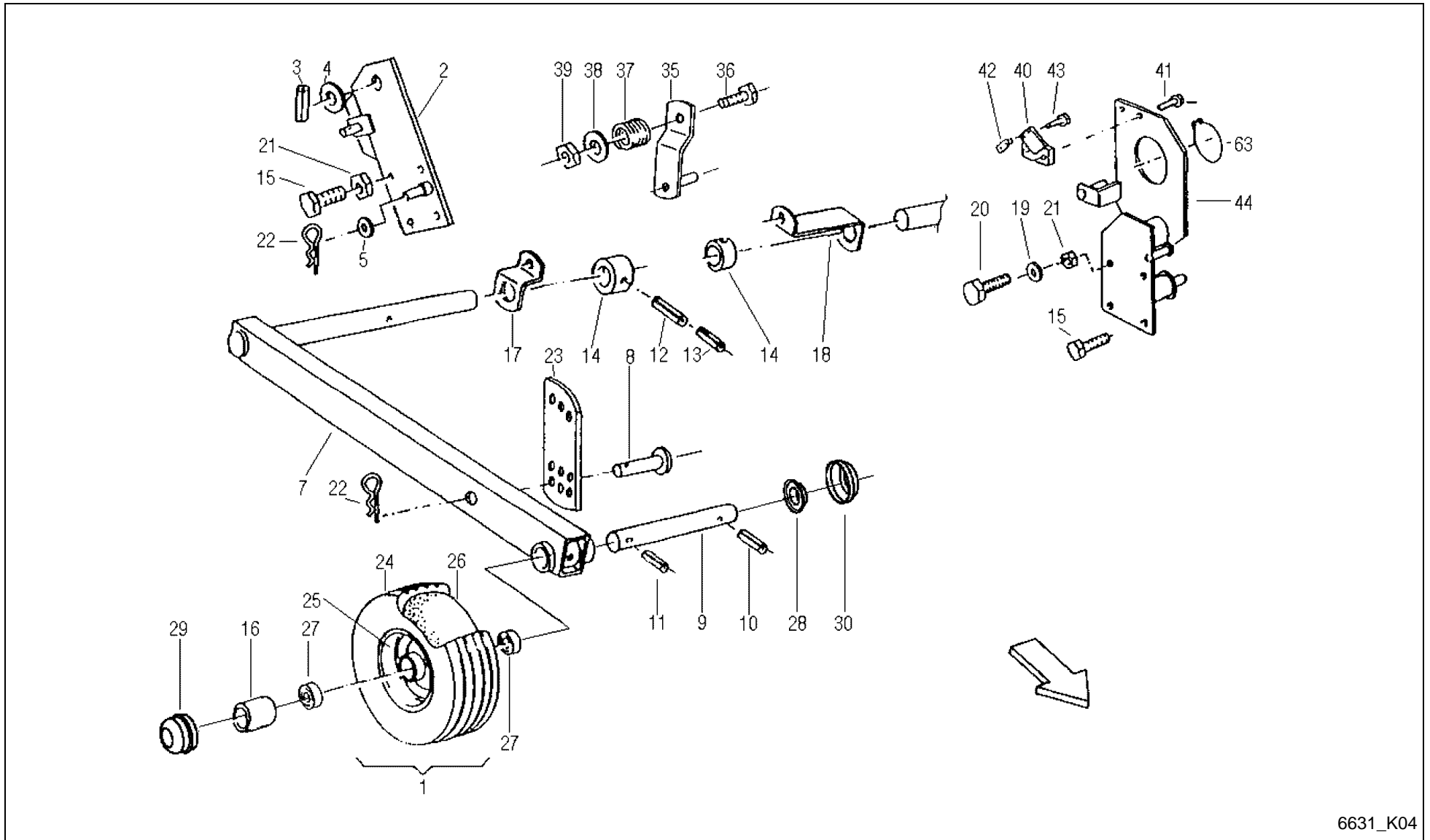

6631_K04

Feedex 360 T / PICK-UP 1.6 TACTILE WHEEL PNEUMATIC TIRE



PosNo.	Part No.	Qty.	Description	Remark
1	VF06564733	2	CPL. WHEEL 15X6.0-6 TT 6PR SILVER RIM	
2	VF16630109	1	RETAINER RIGHT	
3	VF01115460	1	COLLET CHUCK	
4	VF06214234	1	WASHER 31X45X2 GALV.	
5	VF06214226	1	WASHER	
7	VF16517499	2	AXLE LINK	
8	VF06210033	2	PIN	
9	VF16514201	2	PIN/BOLT/STUD	
10	VF01115457	2	DOWEL PIN	
11	VF01157344	1	DOWEL PIN	
12	VF01123863	1	DOWEL PIN	
13	VF01157338	2	DOWEL PIN	
14	VF06577422	2	RING	
15	VF01173914	4	SCR. M10X25D933 8.8 GALV. DIN267-27	
16	VF06576830	2	PIPE	
17	VF06577421	1	SUPPORT	
18	VF06577420	1	SUPPORT	
19	VF01127538	2	WASHER	
20	VF01112429	4	HEX. HEAD SCREW	
21	VF06209768	4	LOCK NUT	
22	VF06215666	4	SPRING CLIP	
23	VF06556744	2	ARM	
24	VF01141364	2	TIRE 15X6.00-6 6PR TT C737	
25	VF06564735	2	RIM 4.50 AX6 SILVER	
26	VF01141365	2	INNER TUBE 15X6,00X6 TR13	
27	VF01124703	4	BEARING	
28	VF06567492	1	BUSH D25+31,5 L13,5	
29	VF06567493	2	WHEEL CAP D 52 H = 36 MM	
30	VF16622598	1	ANTI WRAPPING DEVICE MEFRO 15"+16" ZN	
35	VF06558198	1	LEVER	
36	VF01111298	1	HEX. HEAD SCREW	
37	VF06215308	1	COMPRESSION SPRING	
38	VF01107165	1	WASHER M10 11X20X2 A2C DIN126	
39	VF06209768	1	LOCK NUT	
40	VF06577387	1	GRAPHITE RING	
41	VF06277504	2	HEX. HEAD SCREW	
42	VF06587560	1	SLIDE PIECE	
43	VF01112333	2	HEX. HEAD SCREW	
44	VF16630106	1	SUPPORT	
63	VF01107792	1	CIRCLIP	

Feedex 360 T / PICK-UP 1.6 BAFFLE PLATE WITH ROLE

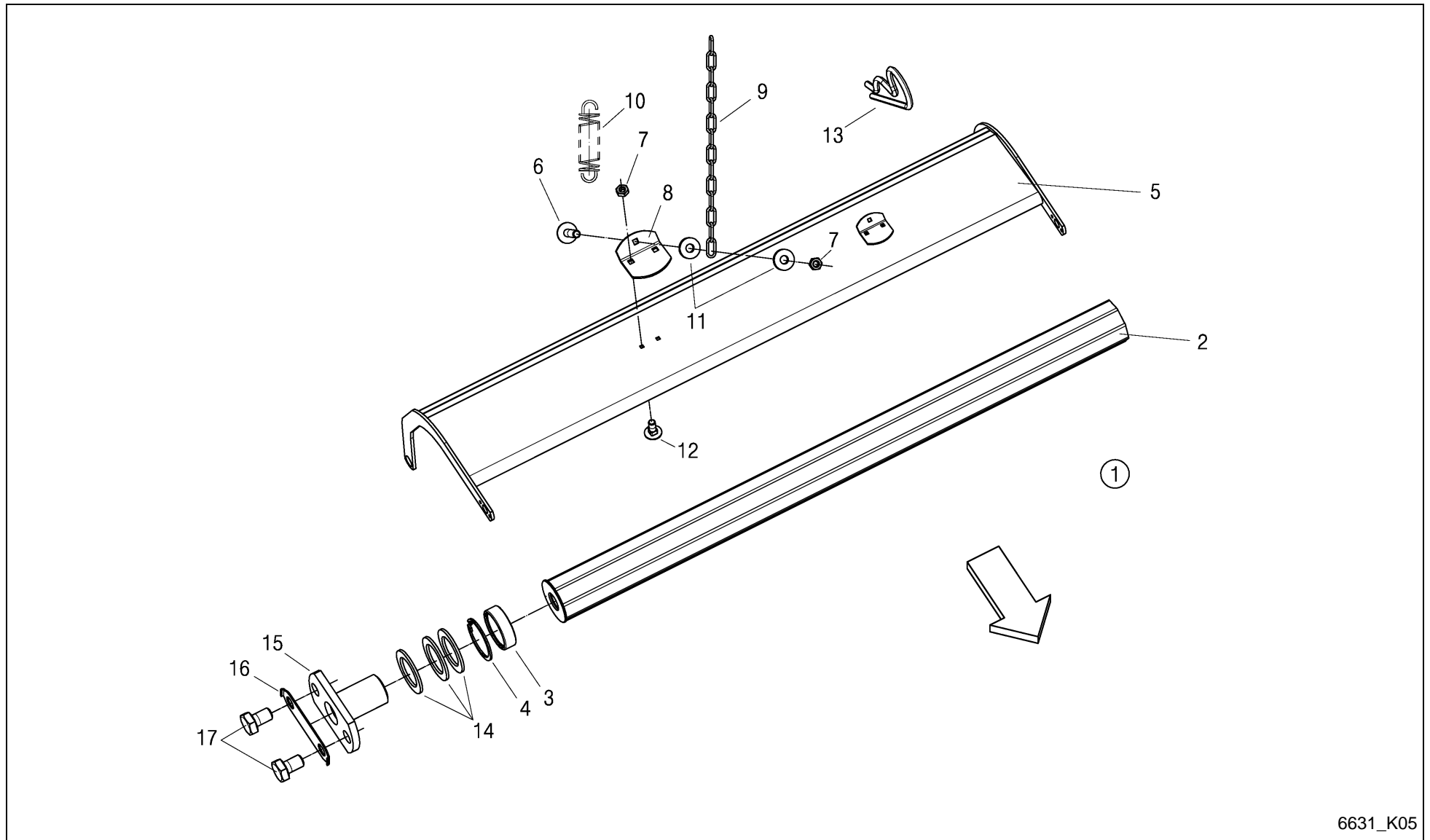

6631_K05



Feedex 360 T / PICK-UP 1.6 BAFFLE PLATE WITH ROLE

PosNo.	Part No.	Qty.	Description	Remark
1	VF16631430	1	BAFFLE PLATE WITH ROLE	
2	VF16631427	1	ROLE PREASSEMBLED	inkl. Pos.3+4
3	VF01136762	2	BEARING	
4	VF01107838	2	CIRCLIP	
5	VF16631429	1	BAFFLE PLATE	
6	VF01137628	2	SAUCER HEAD SCREW	
7	VF01104944	6	NY LOCK NUT 8A3CD985	
8	VF16513473	2	RETAINER	
9	VF01397609	2	CHAIN/TRACK	
10	VF01397931	2	DRAW SPRING	
11	VF01127538	4	WASHER	
12	VF01108524	4	SCREW	
13	VF06215666	2	SPRING CLIP	
14	VF06214313	12	WASHER 26X38X2 GALV.	
15	VF16631126	2	BOLT WELDED	
16	VF16631133	2	SAFETY PLATE	
17	VF01178250	4	HEX. HEAD SCREW	

Feedex 360 T / PICK-UP 1.8 DRUM

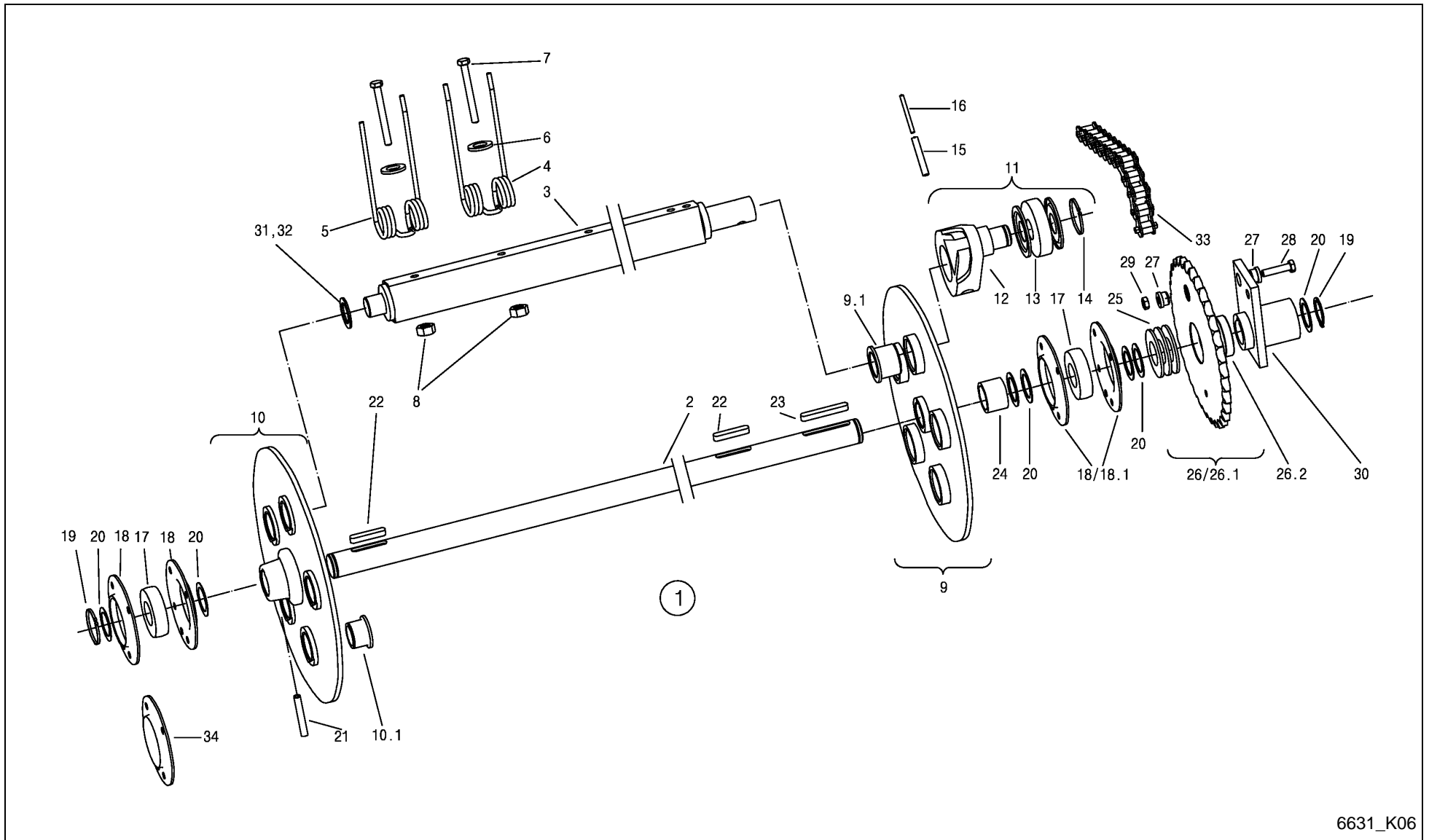

6631_K06



Feedex 360 T / PICK-UP 1.8 DRUM

PosNo.	Part No.	Qty.	Description	Remark
1	VF16630740	1	PICK-UP 1.8	
2	VF16630685	1	DRIVE SHAFT	
3	VF16630682	5	TUBE WELDED	
4	VF06296285	65	PICK-UP TINE, TWIN	+A 2004 - 70St.
5	VF16630684	5	REEL TINE	+A 2004 - 0St.
6	VF01138374	70	WASHER	
7	VF01111184	70	HEX.BOLT	
8	VF01397863	70	WHEEL NUT M8 D6926 8 GALV.	
9	VF16513298	1	ROSETTE	
9.1	VF06571309	5	BUSH	
10	VF16513299	1	ROSETTE	
10.1	VF06246795	5	BUSH	
11	VF16615203	5	CONTROL ARM	
12	VF16615205	5	CONTROL LEVER	
13	VF06215027	5	LAUFROLLE LR 203NPPU 17X47X12	
14	VF01107726	5	CIRCLIP	
15	VF01157382	5	ROLL PIN 10X65 EN ISO 8752 ZN.FL.	
16	VF01157348	5	DOWEL PIN	
17	VF16630709	2	FLANGED SLEEVE 1726206 2RS	
18	VF16630686	2	SHEET METAL CASE 2-PIECE	+A 2004 - 1St.
18.1	VF16631187	1	BEARING FLANGE 2-PIECE	+A 2004 mit 21.1 K08
19	VF01107742	2	CIRCLIP	
20	VF06214481	10	SPACER 30X42X1 DIN988	+A 2004 mit 18.1- 15St.
21	VF06208913	2	ALLEN SET SCREW, INT. HEX.	
22	VF06212426	2	FITTING KEY	
23	VF16630743	1	FITTING KEY A8X7X60	
24	VF16630766	1	SPACER RING	
25	VF06214420	3	DISC	+A 2004 mit 18.1- 15St.
26	VF16630156	1	CHAIN SPROCKET Z=34	für 6R -A 2005
26.1	VF06577432	1	CHAIN SPROCKET	für 4R +A 2006 a. für 6R
26.2	VF06277516	1	BEARING BUSH	
27	VF06571314	2	BUSH	
28	VF16630966	1	SHEAR SCREW	
29	VF01104944	1	NY LOCK NUT 8A3CD985	
30	VF16630744	1	FLANGED HUB	
31	VF06214314	5	WASHER 26X38X1 GALV.	
32	VF06214313	5	WASHER 26X38X2 GALV.	
33	VF16630768.01	1	CHAIN 12B-1VX90E	für 6R -A 2006
33	VF16630767.01	1	CHAIN 12B-1VX89L	für 4R +A 2006 für alle
34	VF16631868	1	COVER	V; +A 2012-Serie

Feedex 360 T / PICK-UP 1.8 DRUM (+A 2004)

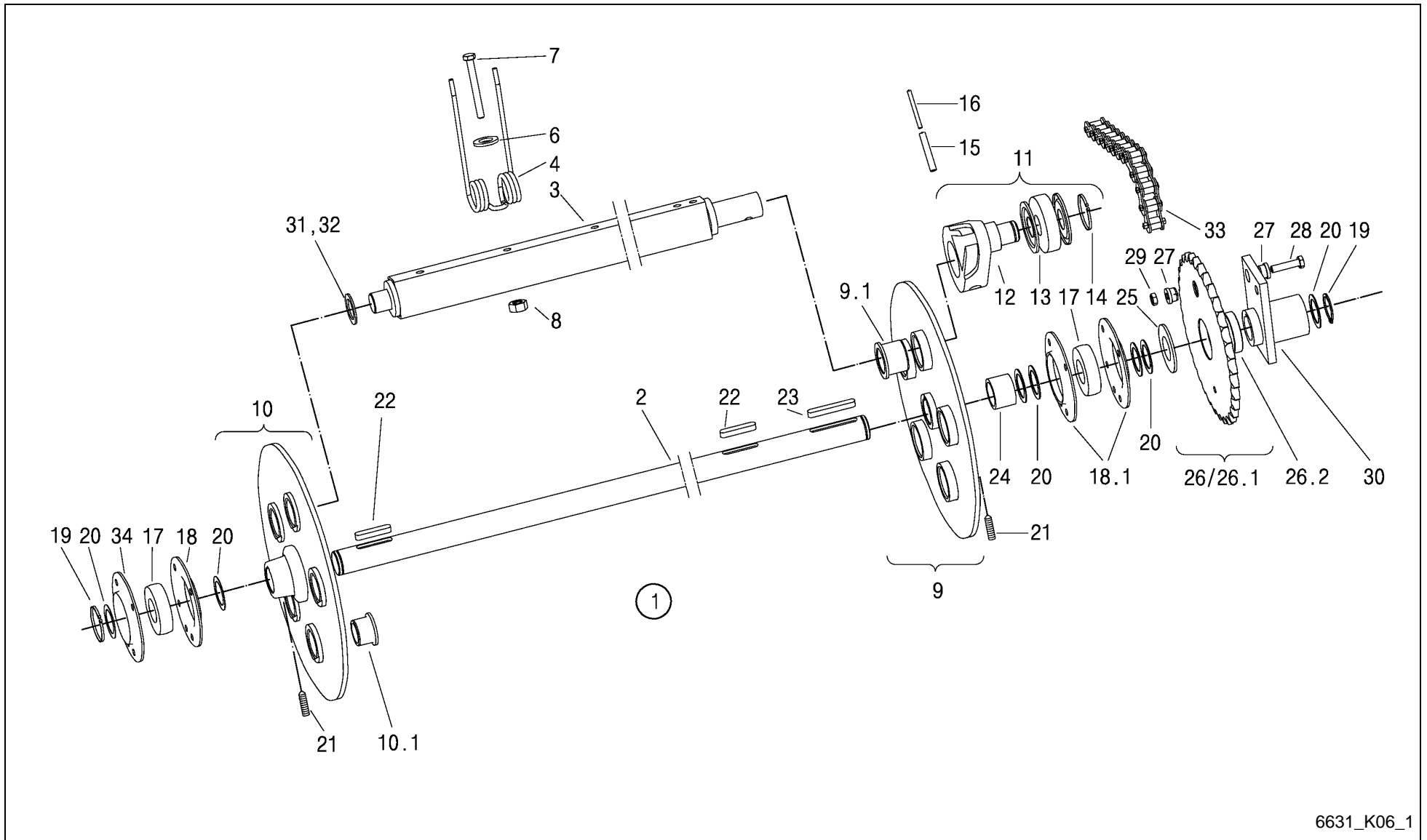

6631_K06_1



Feedex 360 T / PICK-UP 1.8 DRUM (+A 2004)

PosNo.	Part No.	Qty.	Description	Remark
1	A143030430	1	PICK-UP 1.8 ASSEMBLED	
2	VF16630685	1	DRIVE SHAFT	
3	VF16630682	5	TUBE WELDED	
4	VF06296285	70	PICK-UP TINE, TWIN	
6	VF01138374	70	WASHER	
7	VF01111184	70	HEX.BOLT	
8	VF01397863	70	WHEEL NUT M8 D6926 8 GALV.	
9	VF16513298	1	ROSETTE	
9.1	VF06571309	5	BUSH	
10	VF16513299	1	ROSETTE	
10.1	VF06246795	5	BUSH	
11	VF16615203	5	CONTROL ARM	
12	VF16618715	5	LEVER	
13	VF06215027	5	LAUFROLLE LR 203NPPU 17X47X12	
14	VF01107726	5	CIRCLIP	
15	VF01157382	5	ROLL PIN 10X65 EN ISO 8752 ZN.FL.	
16	VF01157348	5	DOWEL PIN	
17	VF16630709	2	FLANGED SLEEVE 1726206 2RS	
18	VF16630686	0.5000	SHEET METAL CASE 2-PIECE	
18.1	VF16631187	1	BEARING FLANGE 2-PIECE	2x VF16630769
19	VF01107742	2	CIRCLIP	
20	VF06214481	20	SPACER 30X42X1 DIN988	
21	VF06208913	2	ALLEN SET SCREW, INT. HEX.	
22	VF06212426	2	FITTING KEY	
23	VF16630743	1	FITTING KEY A8X7X60	
24	VF16630766	1	SPACER RING	
25	VF06214420	1	DISC	
26	VF16630156	1	CHAIN SPROCKET Z=34	-A 2005 für 6R
26.1	VF06577432	1	CHAIN SPROCKET	für 4R; +A 2006 auch für 6R
26.2	VF06277516	1	BEARING BUSH	
27	VF06571314	2	BUSH	
28	VF16630966	1	SHEAR SCREW	
29	VF01104944	1	NY LOCK NUT 8A3CD985	
30	VF16630744	1	FLANGED HUB	
31	VF06214314	5	WASHER 26X38X1 GALV.	
32	VF06214313	5	WASHER 26X38X2 GALV.	
33	VF16630768.01	1	CHAIN 12B-1VX90E	-A 2005 für 6R
33	VF16630767.01	1	CHAIN 12B-1VX89L	+A 2006
34	VF16631868	1	COVER	

Feedex 360 T / PICK-UP BAFFLE-PLATE

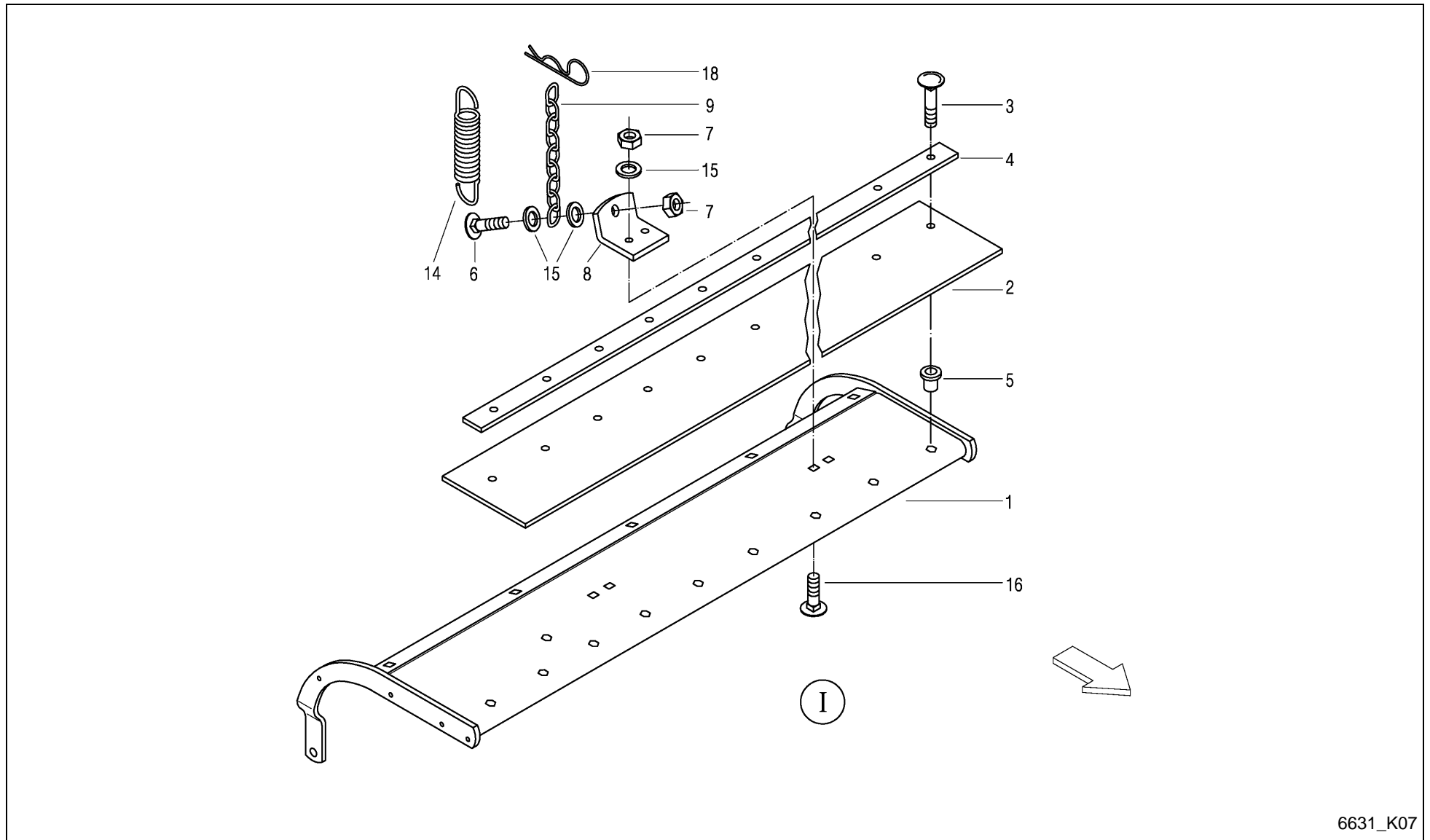

6631_K07

Feedex 360 T / PICK-UP BAFFLE-PLATE



PosNo.	Part No.	Qty.	Description	Remark
1	VF16630737	1	BAFFLE PLATE	
1	VF16630730	1	BAFFLE PLATE PU 1.8	X I
2	VF16611479	1	RUBBER BAR	X I
3	VF01142806	9	TRUSS-HEAD SCREW	X I
4	VF06578934	1	STRIP	X I
5	VF01142805	9	RIVET NUT	X I
6	VF01137628	2	SAUCER HEAD SCREW	
7	VF01104944	6	NY LOCK NUT 8A3CD985	X I
8	VF16513473	2	RETAINER	X I
9	VF01397609	2	CHAIN/TRACK	
14	VF01397931	2	DRAW SPRING	
15	VF01127538	4	WASHER	
16	VF01108524	4	SCREW	X I
18	VF06215666	2	SPRING CLIP	

Feedex 360 T / PICK-UP SCAPPER

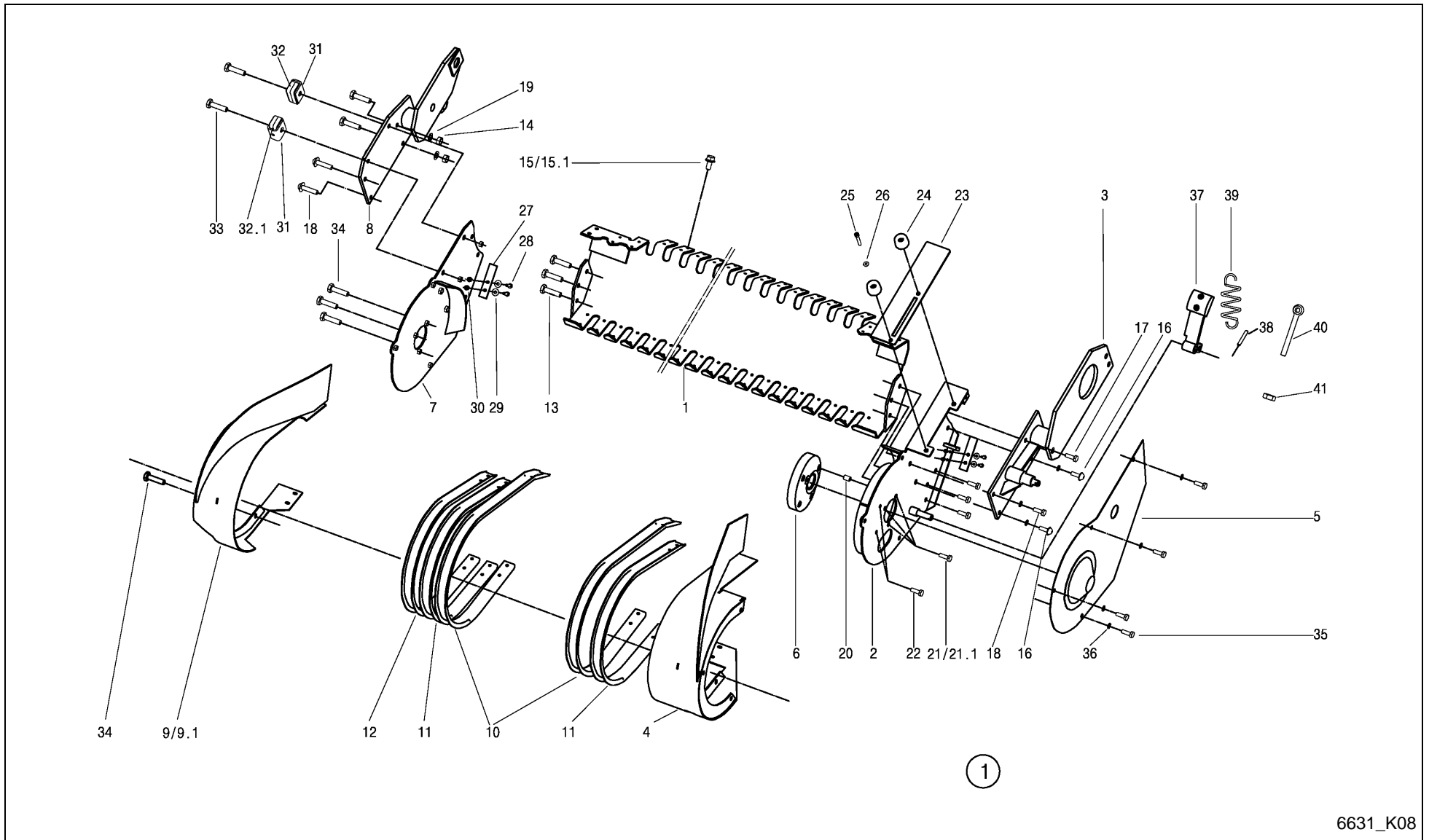

6631_K08

Feedex 360 T / PICK-UP SCAPPER



PosNo.	Part No.	Qty.	Description	Remark
1	VF16630705	1	SUPPORT	
2	VF16630695	1	SIDE MEMBER LEFT	
3	VF16630690	1	SUPPORT LEFT	
4	VF16630716	1	COVERING LEFT WELDED	
5	VF16630738	1	GUARD PLATE	
6	VF06296264	1	STEERING PLATE	
7	VF16630700	1	SIDE MEMBER RIGHT	
8	VF16630710	1	SUPPORT RIGHT WELDED	
9	VF16630736	1	COVERING	
9.1	VF16630736.01	1	COVERING PU 1,8	+A 2004
10	VF16630706	24	SHEET	
11	VF16630707	2	SHEET OUTSIDE	
12	VF16630746	1	SHEET SHORT	
13	VF01112418	6	BOLT, SCREW	
14	VF06209768	4	LOCK NUT	
15	VF06273854	114	HEX. HEAD SCREW	
15.1	VF0905191000	114	GEWINDEFURCHSCHRAUBE M 6 X 16	E Pos.15 +A 2009 Serie
16	VF01142213	22	TRUSS-HEAD SCREW	
17	VF01112429	3	HEX. HEAD SCREW	
18	VF01173914	3	SCR. M10X25D933 8.8 GALV. DIN267-27	
19	VF01127538	4	WASHER	
20	VF16614668	3	PIN, TENSION	
21	VF01111136	3	VIS	
21.1	VF16631186	3	BOLT M8X45 D933 8.8	+A 2004 mit Pos 18.1/K06
22	VF06209476	2	BOLT M8X30 D933 8.8 A3C DIN267-27 COATE	
23	VF16630721	1	CRANK PU 1,8	
24	VF01141112	2	RUBBER PAD	
25	VF16630742	2	SCREW M8X35 DIN912 8.8	
26	VF01107163	2	WASHER	
27	VF16630734	2	RUBBER SHEET	
28	VF01112264	4	HEX. HEAD SCREW	
29	VF06214189	4	WASHER 6,4X18X2 A2C	
30	VF01114357	4	LOCK NUT	
31	VF06571322	2	YOKE	
32	VF06571323	4	STOP	
32.1	VF16635132	1	LIMIT STOP	+A 2012 Serie
33	VF01112451	2	HEX. HEAD SCREW	
34	VF01173381	9	SCR.M8X20 D933 8.8 GALV.DIN267-27MKL	
35	VF01112307	4	HEX. HEAD SCREW	
36	VF16631181	4	WASHER A8	

Feedex 360 T / PICK-UP SCAPPER

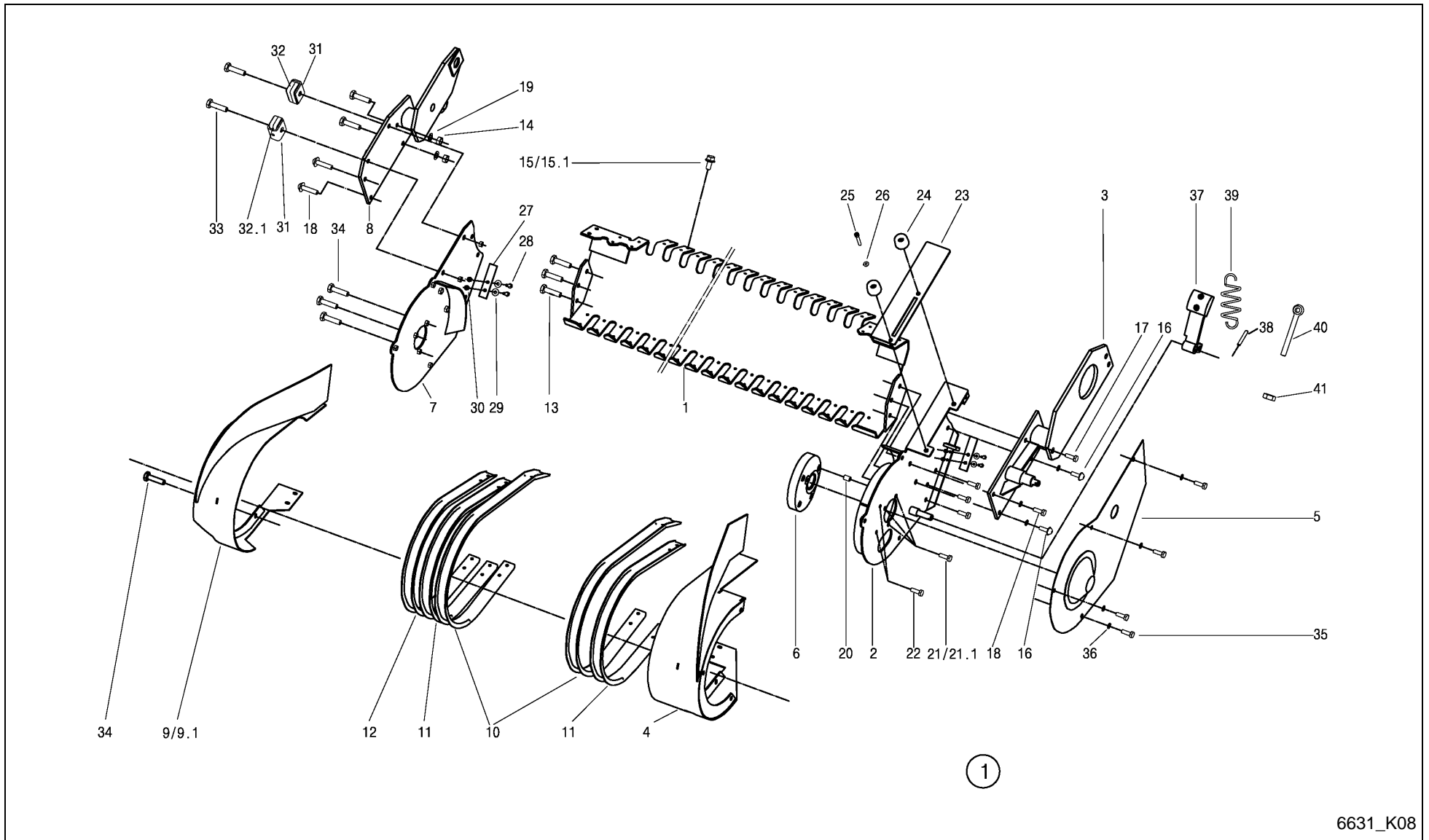

6631_K08

Feedex 360 T / PICK-UP SCAPPER



PosNo.	Part No.	Qty.	Description	Remark
37	VF16630745	1	TENSIONER	
38	VF01115441	1	DOWEL PIN	
39	VF06215561	1	TENSION SPRING	
40	VF01138951	1	EYE BOLT LBM 8X 50 DIN 444 - 4.6	
41	VF01112824	2	HEX. NUT	

Feedex 360 T / PICK-UP 1.8 TACTILE WHEEL PNEUMATIC TIRE

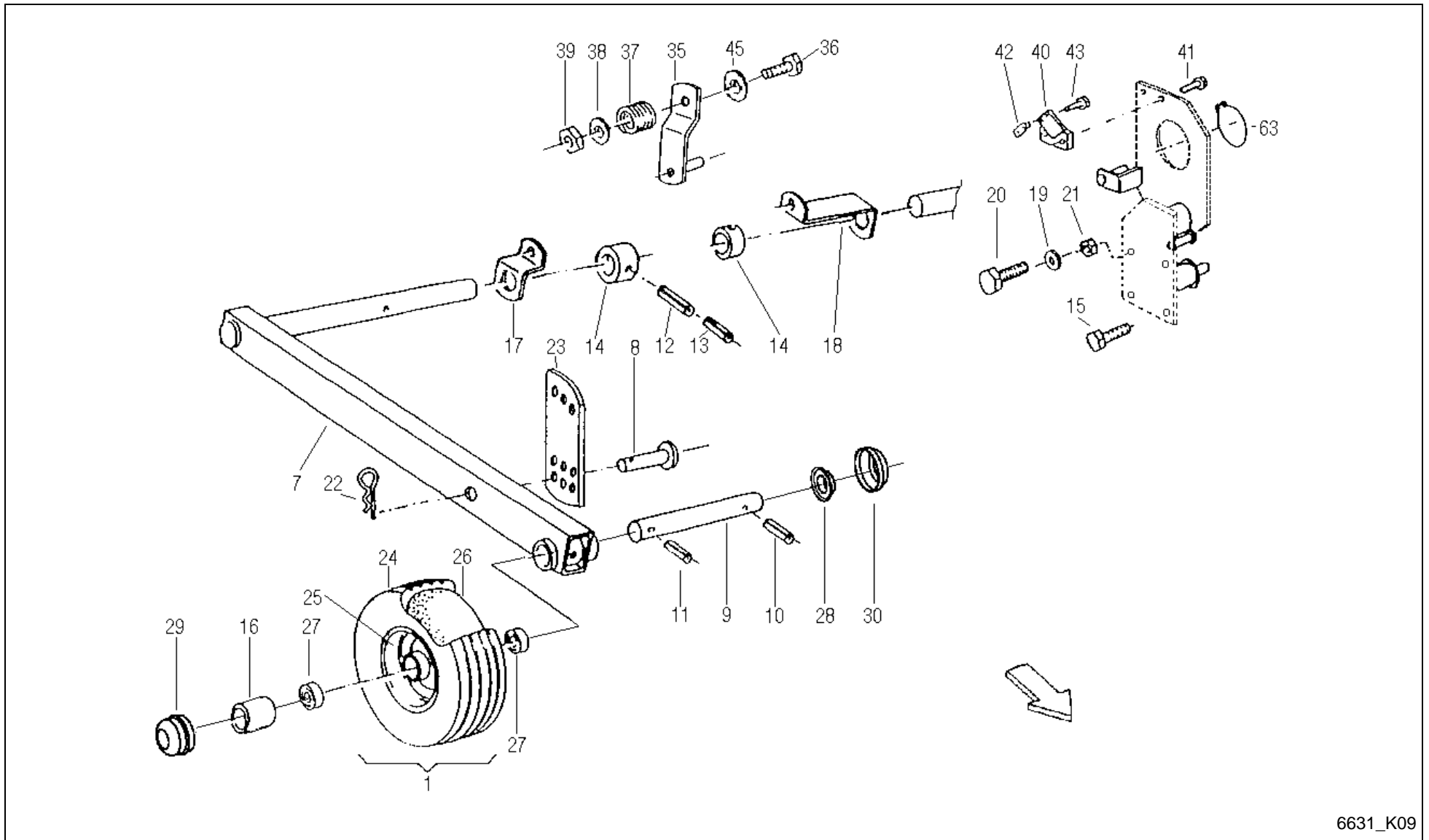

6631_K09

Feedex 360 T / PICK-UP 1.8 TACTILE WHEEL PNEUMATIC TIRE



PosNo.	Part No.	Qty.	Description	Remark
1	VF06564733	2	CPL. WHEEL 15X6.0-6 TT 6PR SILVER RIM	
7	VF16517499	2	AXLE LINK	
8	VF06210033	2	PIN	
9	VF16514201	2	PIN/BOLT/STUD	
10	VF01115457	2	DOWEL PIN	
11	VF01157344	2	DOWEL PIN	
12	VF01123863	2	DOWEL PIN	
13	VF01157338	2	DOWEL PIN	
14	VF06577422	2	RING	
15	VF01173914	4	SCR. M10X25D933 8.8 GALV. DIN267-27	
16	VF06576830	2	PIPE	
17	VF06577421	1	SUPPORT	
18	VF06577420	1	SUPPORT	
19	VF01127538	2	WASHER	
20	VF01112429	4	HEX. HEAD SCREW	
21	VF06209768	4	LOCK NUT	
22	VF06215666	4	SPRING CLIP	
23	VF06556744	2	ARM	
24	VF01141364	2	TIRE 15X6.00-6 6PR TT C737	
25	VF06564735	2	RIM 4.50 AX6 SILVER	
26	VF01141365	2	INNER TUBE 15X6,00X6 TR13	
27	VF01124703	4	BEARING	
28	VF01167577	4	ND 6198	
29	VF06580546	2	CAP	
30	VF06567492	2	BUSH D25+31,5 L13,5	
35	VF06558198	1	LEVER	
36	VF01111315	1	HEX.HEAD SCREW	
37	VF06215308	1	COMPRESSION SPRING	
38	VF01107165	1	WASHER M10 11X20X2 A2C DIN126	
39	VF06209768	1	LOCK NUT	
40	VF06577387	1	GRAPHITE RING	
41	VF06277504	2	HEX. HEAD SCREW	
42	VF06587560	1	SLIDE PIECE	
43	VF01112333	2	HEX. HEAD SCREW	
45	KG01273861	1	WASHER DIN7349 M14 A3C	
63	VF01107792	1	CIRCLIP	

Feedex 360 T / PICK-UP 1.8 BAFFLE PLATE WITH ROLE

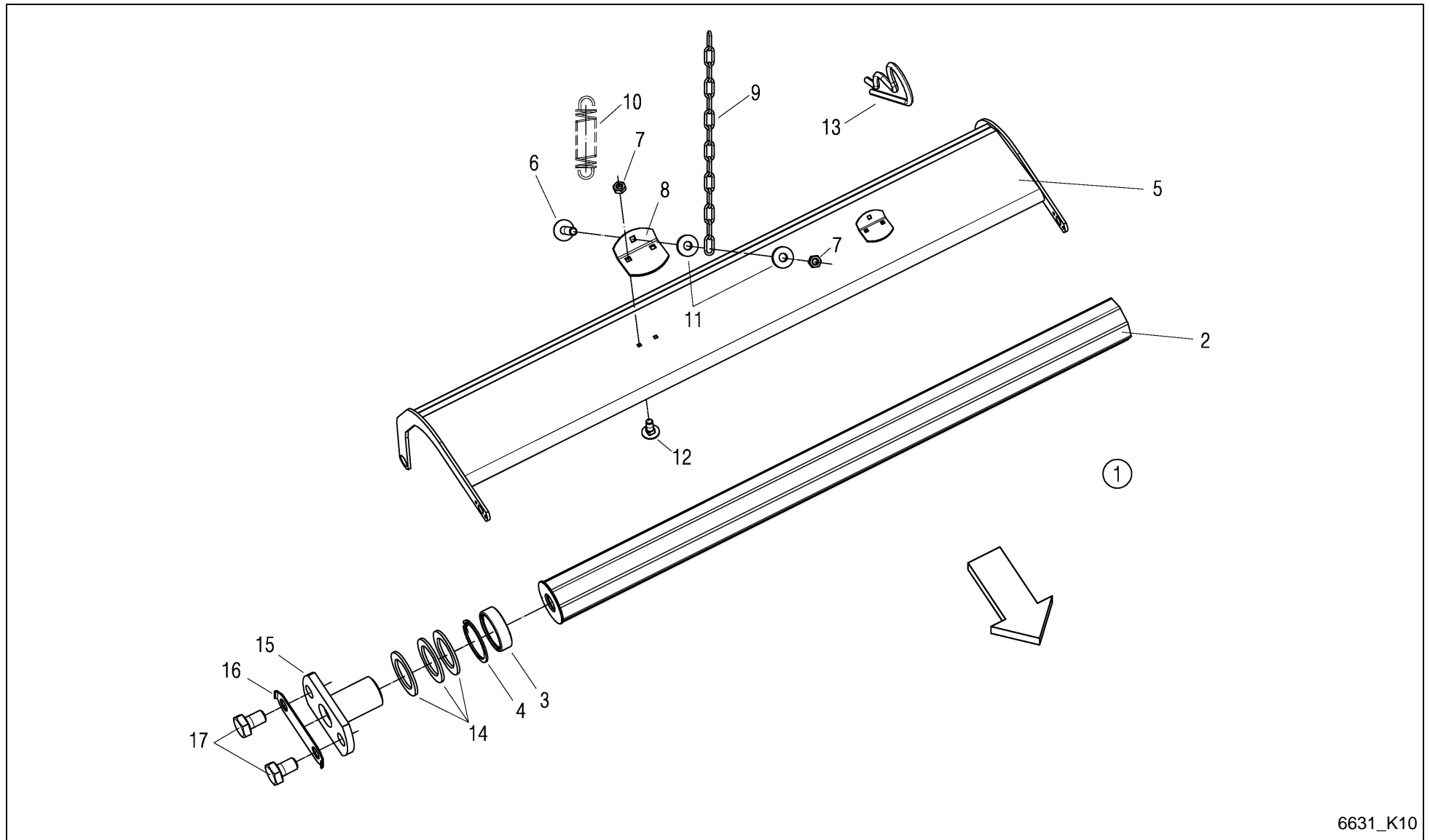

6631_K10



Feedex 360 T / PICK-UP 1.8 BAFFLE PLATE WITH ROLE

PosNo.	Part No.	Qty.	Description	Remark
1	VF16631135	1	BAFFLE PLATE WITH ROLE	
2	VF16631134	1	ROLE PREASSEMBLED	inkl. Pos.3+4
3	VF01136762	2	BEARING	
4	VF01107838	2	CIRCLIP	
5	VF16631129	1	BAFFLE PLATE WELDED	
6	VF01137628	2	SAUCER HEAD SCREW	
7	VF01104944	6	NY LOCK NUT 8A3CD985	
8	VF16513473	2	RETAINER	
9	VF01397609	2	CHAIN/TRACK	
10	VF01397931	2	DRAW SPRING	
11	VF01127538	4	WASHER	
12	VF01108524	4	SCREW	
13	VF06215666	2	SPRING CLIP	
14	VF06214313	12	WASHER 26X38X2 GALV.	
15	VF16631126	2	BOLT WELDED	
16	VF16631133	2	SAFETY PLATE	
17	VF01178250	4	HEX. HEAD SCREW	

Feedex 360 T / SCRAPER FLOOR BOARDS

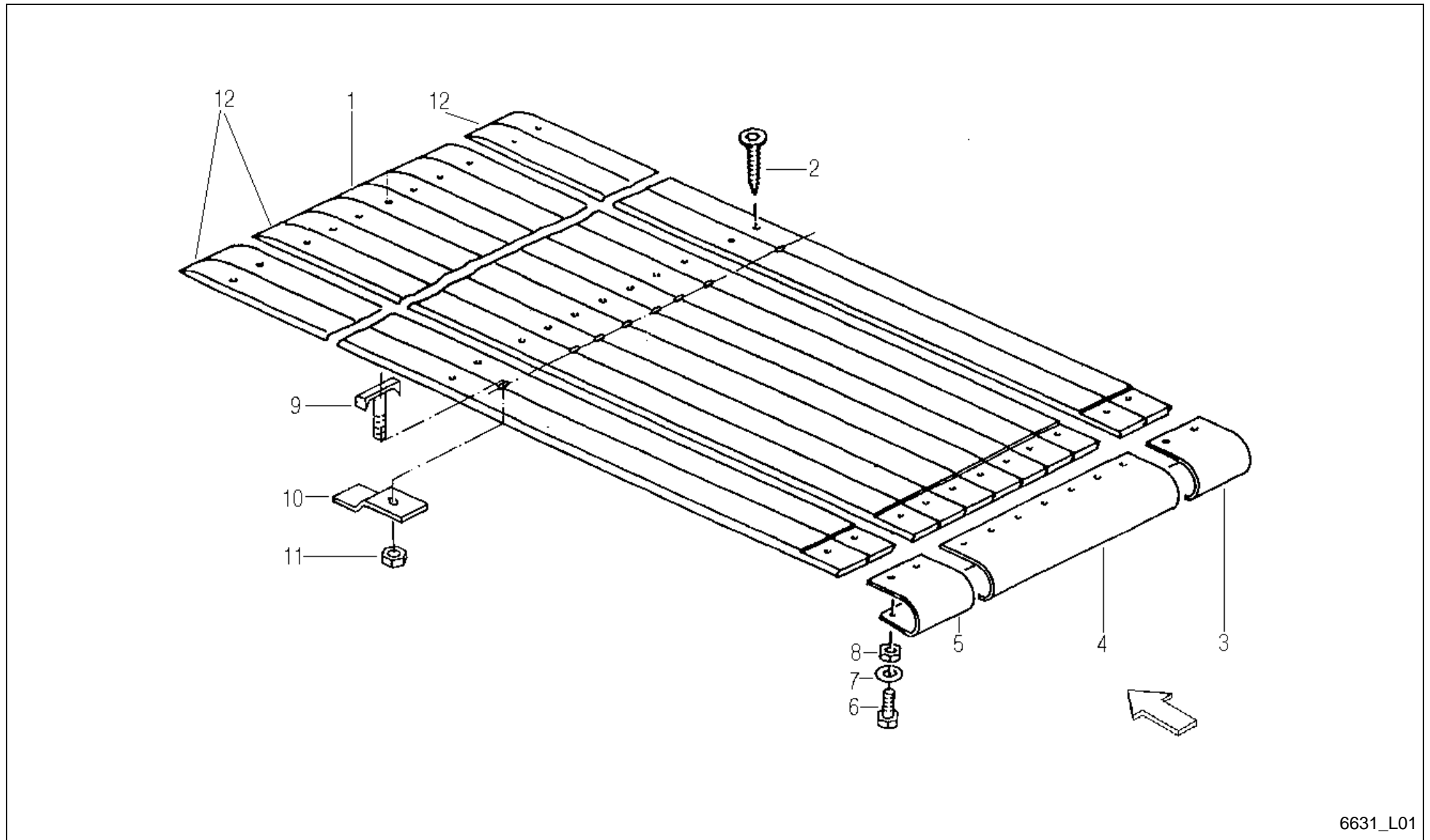

6631_L01



Feedex 360 T / SCRAPER FLOOR BOARDS

PosNo.	Part No.	Qty.	Description	Remark
1	VF06570925	8	PLANK/BOARD	
2	VF01142958	42	SELF-DRILLING SCREW 8X65 SCT 10/35 ZN	
3	VF16515750	1	COVER PLATE, RH	
4	VF16515748	1	COVER PLATE	
5	VF16515749	1	COVER PLATE, LH	
6	VF01112322	5	HEX. HEAD SCREW	
7	VF06214193	5	WASHER 8,4X21X3 GALV.	
8	VF01104944	5	NY LOCK NUT 8A3CD985	
9	VF06213700	8	CLAMP SCREW/BOLT	
10	VF16511031	8	TIGHTENING PLATE	
11	VF01112824	8	HEX. NUT	
12	VF16613374	3	PLANK/BOARD	

Feedex 360 T / SCRAPER FLOOR

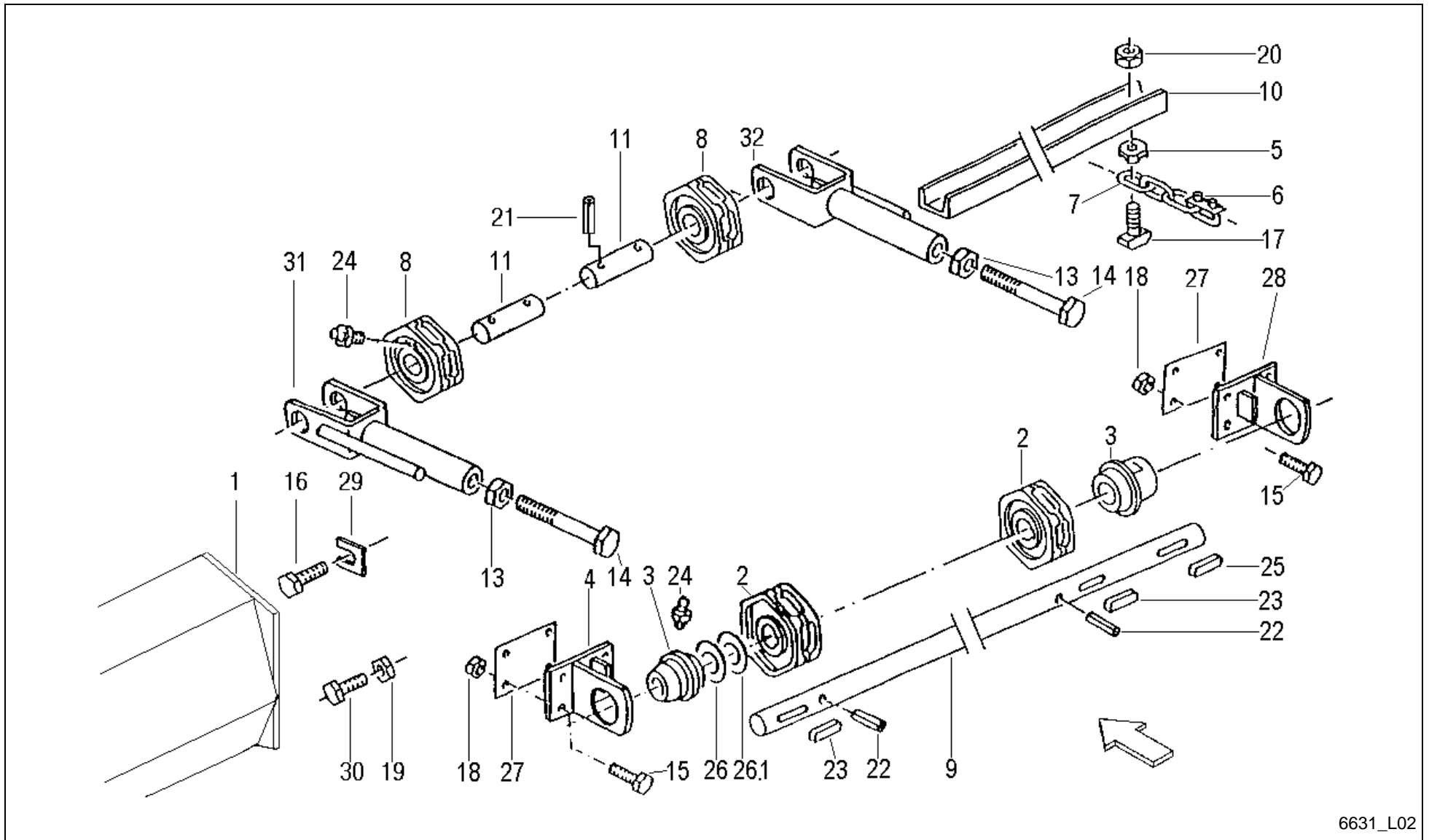

6631_L02

Feedex 360 T / SCRAPER FLOOR



PosNo.	Part No.	Qty.	Description	Remark
1	VF16613296	1	COVER PLATE	
2	VF06578349	2	CHAIN SPROCKET	
3	VF06577064	2	FLANGED SLEEVE	
4	VF06578750	1	SUPPORT PLATE	
5	VF06587602	40	DRIVE FLANGE	
6	VF06587598	2	CHAIN LOCK	
7	VF06578761	2	ROLLER CHAIN 10 X 31 315 CHAIN LINKS	
8	VF06578826	2	SPROCKET	
9	VF16515751	1	AXLE	
10	VF06558644	20	RAIL	
11	VF06577030	2	SHAFT	
13	VF01112916	2	HEX. NUT	
14	VF06209411	2	HEX.BOLT	
15	VF01112429	4	HEX. HEAD SCREW	
16	VF06209484	1	HEX.HEAD.SCREW	
17	VF06273686	40	HAMMER BOLT	
18	VF06209768	4	LOCK NUT	
19	VF06209769	3	LOCK NUT	
20	VF06209768	40	LOCK NUT	
21	VF01157337	4	DOWEL PIN	
22	VF01115478	2	DOWEL PIN	
23	VF01118100	2	FITTING KEY	
24	VF01120692	4	GREASE NIPPLE H1 AM 6X1 DIN 71412	
25	VF01118111	1	SUNK KEY	
26	VF06214332	4	WASHER	
26.1	VF06214333	1	WASHER	
27	VF06577968	6	SHIM	
28	VF06550287	1	SUPPORT PLATE	
29	VF06552196	6	SHIM	
30	VF01112529	3	HEX.HEAD SCREW	
31	VF16611400	1	TENSION FORK	
32	VF16611401	1	TENSION FORK	

Feedex 360 T / DRUM ELEVATOR GRATE 4 RAKE

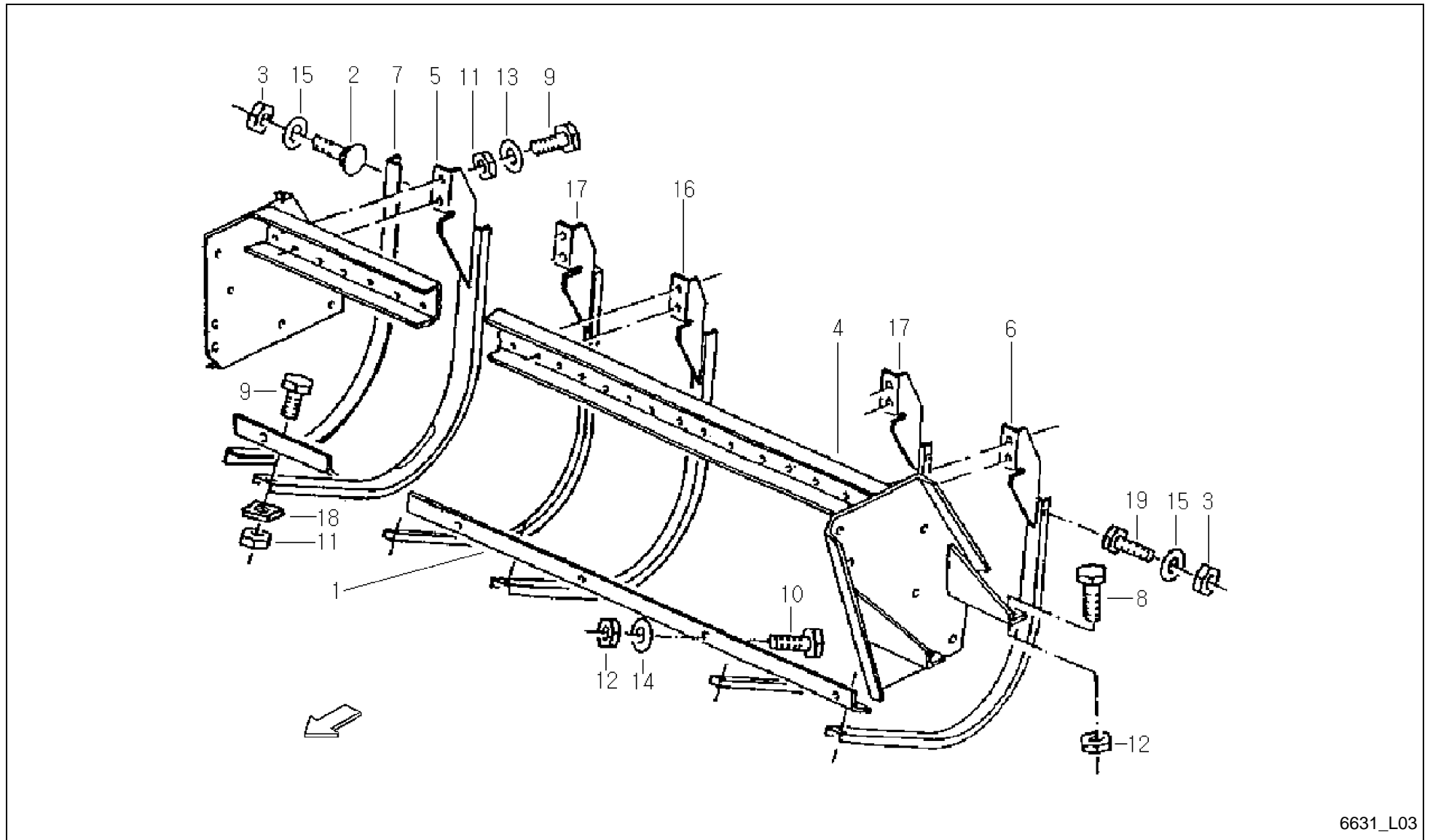

6631_L03



Feedex 360 T / DRUM ELEVATOR GRATE 4 RAKE

PosNo.	Part No.	Qty.	Description	Remark
1	VF16611247	1	GUIDA RAIL	
2	VF01142565	6	TRUSS-HEAD SCR. M8X20 109 GALV.	
3	VF01104944	7	NY LOCK NUT 8A3CD985	
4	VF16613354	1	SUPPORT	
5	VF16613460	1	GUIDE RAIL	
6	VF16613456	1	GUIDE RAIL	
7	VF06577579	1	ANGLE	
8	VF06209459	4	SCREW M12X35D933 8.8 A3C DIN267-27 COATE	
9	VF01112429	60	HEX. HEAD SCREW	
10	VF01112538	5	HEX.HEAD SCREW	
11	VF06209768	60	LOCK NUT	
12	VF06209769	5	LOCK NUT	
13	VF01127538	40	WASHER	
14	VF06214206	5	WASHER 13X30X4 RM=580-680 MPA A2C	
15	VF01107163	7	WASHER	
16	VF16613356	14	GUIDE RAIL	
17	VF16613458	4	BEND	
18	VF06552906	16	CLIP	
19	VF01112322	1	HEX. HEAD SCREW	

Feedex 360 T / DRUM ELEVATOR GRATE 6 RAKE

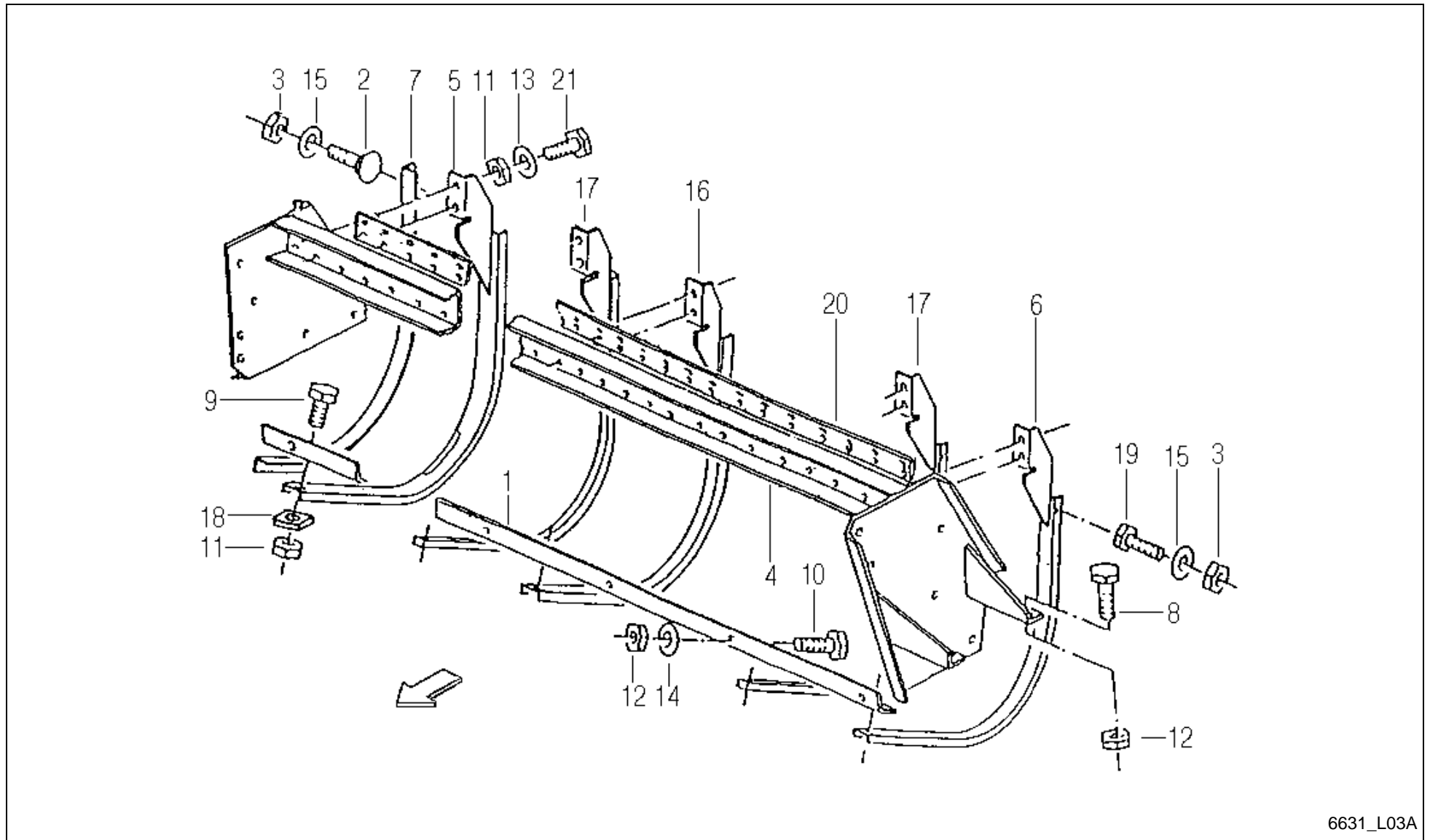

6631_L03A



Feedex 360 T / DRUM ELEVATOR GRATE 6 RAKE

PosNo.	Part No.	Qty.	Description	Remark
1	VF16630147	1	GUIDA RAIL	
2	VF01142565	6	TRUSS-HEAD SCR. M8X20 109 GALV.	
3	VF01104944	7	NY LOCK NUT 8A3CD985	
4	VF16613354	1	SUPPORT	
5	VF16613460	1	GUIDE RAIL	
6	VF16613456	1	GUIDE RAIL	
7	VF06577579	1	ANGLE	
8	VF06209459	4	SCREW M12X35D933 8.8 A3C DIN267-27 COATE	
9	VF01112429	20	HEX. HEAD SCREW	
10	VF01112538	5	HEX.HEAD SCREW	
11	VF06209768	60	LOCK NUT	
12	VF06209769	5	LOCK NUT	
13	VF01127538	40	WASHER	
14	VF06214206	5	WASHER 13X30X4 RM=580-680 MPA A2C	
15	VF01107163	7	WASHER	
16	VF16613356	15	GUIDE RAIL	
17	VF16613458	2	BEND	
18	VF06552906	16	CLIP	
19	VF01112322	1	HEX. HEAD SCREW	
20	VF16630148	1	PLATE	
21	VF01112447	40	HEX.HEAD SCREW	

Feedex 360 T / DRUM ELEVATOR GRATE 5 RAKE

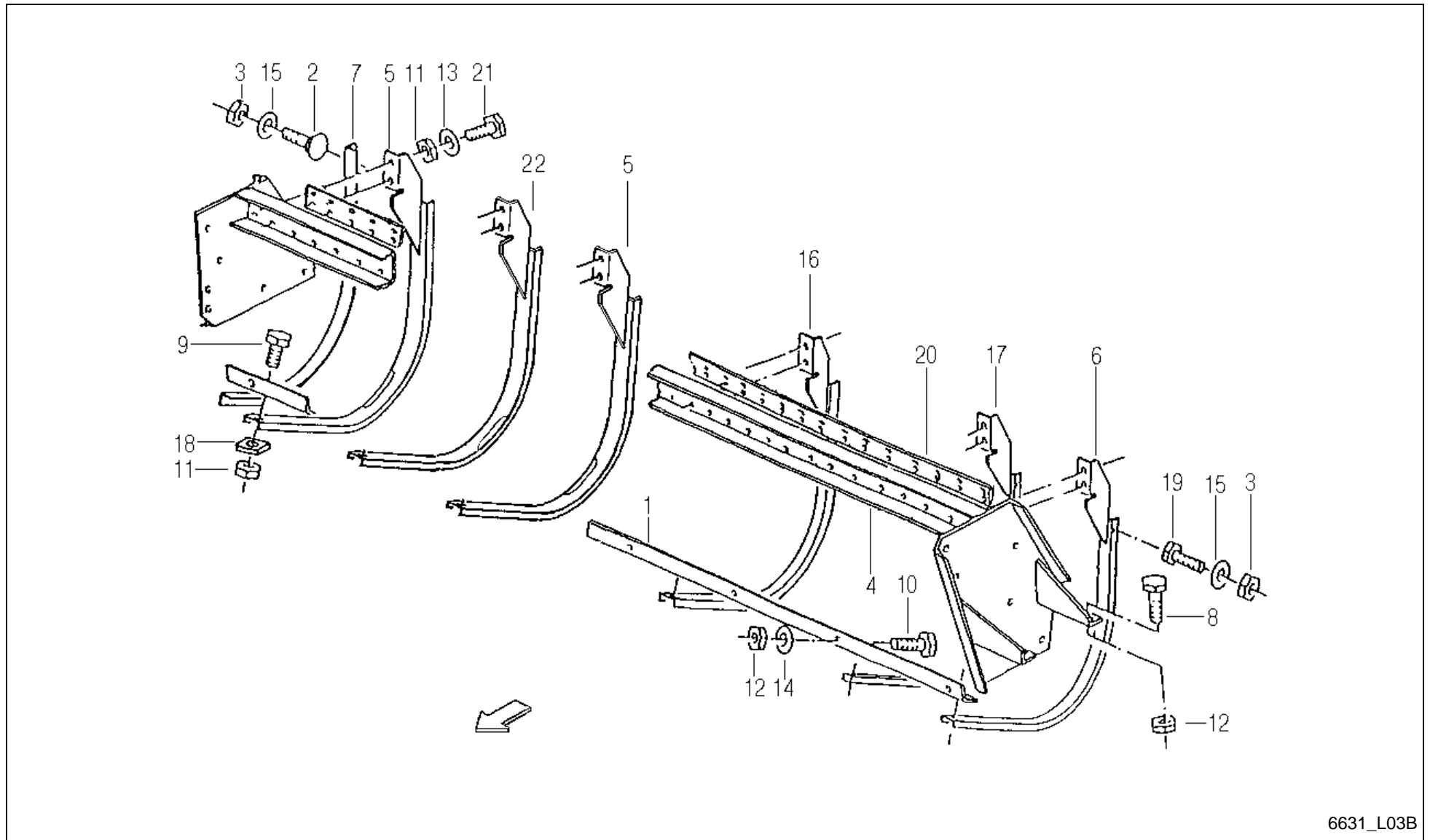

6631_L03B



Feedex 360 T / DRUM ELEVATOR GRATE 5 RAKE

PosNo.	Part No.	Qty.	Description	Remark
1	VF16630147	1	GUIDA RAIL	
2	VF01142565	6	TRUSS-HEAD SCR. M8X20 109 GALV.	
3	VF01104944	7	NY LOCK NUT 8A3CD985	
4	VF16613354	1	SUPPORT	
5	VF16613460	2	GUIDE RAIL	
6	VF16613456	1	GUIDE RAIL	
7	VF06577579	1	ANGLE	
8	VF06209459	4	SCREW M12X35D933 8.8 A3C DIN267-27 COATE	
9	VF01112429	20	HEX. HEAD SCREW	
10	VF01112538	5	HEX.HEAD SCREW	
11	VF06209768	60	LOCK NUT	
12	VF06209769	5	LOCK NUT	
13	VF01127538	40	WASHER	
14	VF06214206	5	WASHER 13X30X4 RM=580-680 MPA A2C	
15	VF01107163	7	WASHER	
16	VF16613356	14	GUIDE RAIL	
17	VF16613458	1	BEND	
18	VF06552906	19	CLIP	
19	VF01112322	1	HEX. HEAD SCREW	
20	VF16630148	1	PLATE	
21	VF01112447	40	HEX.HEAD SCREW	
22	VF16630964	1	GUIDE RAIL WELDED	

Feedex 360 T / DRUM ELEVATOR SIDE MEM. A. COV .SHEET

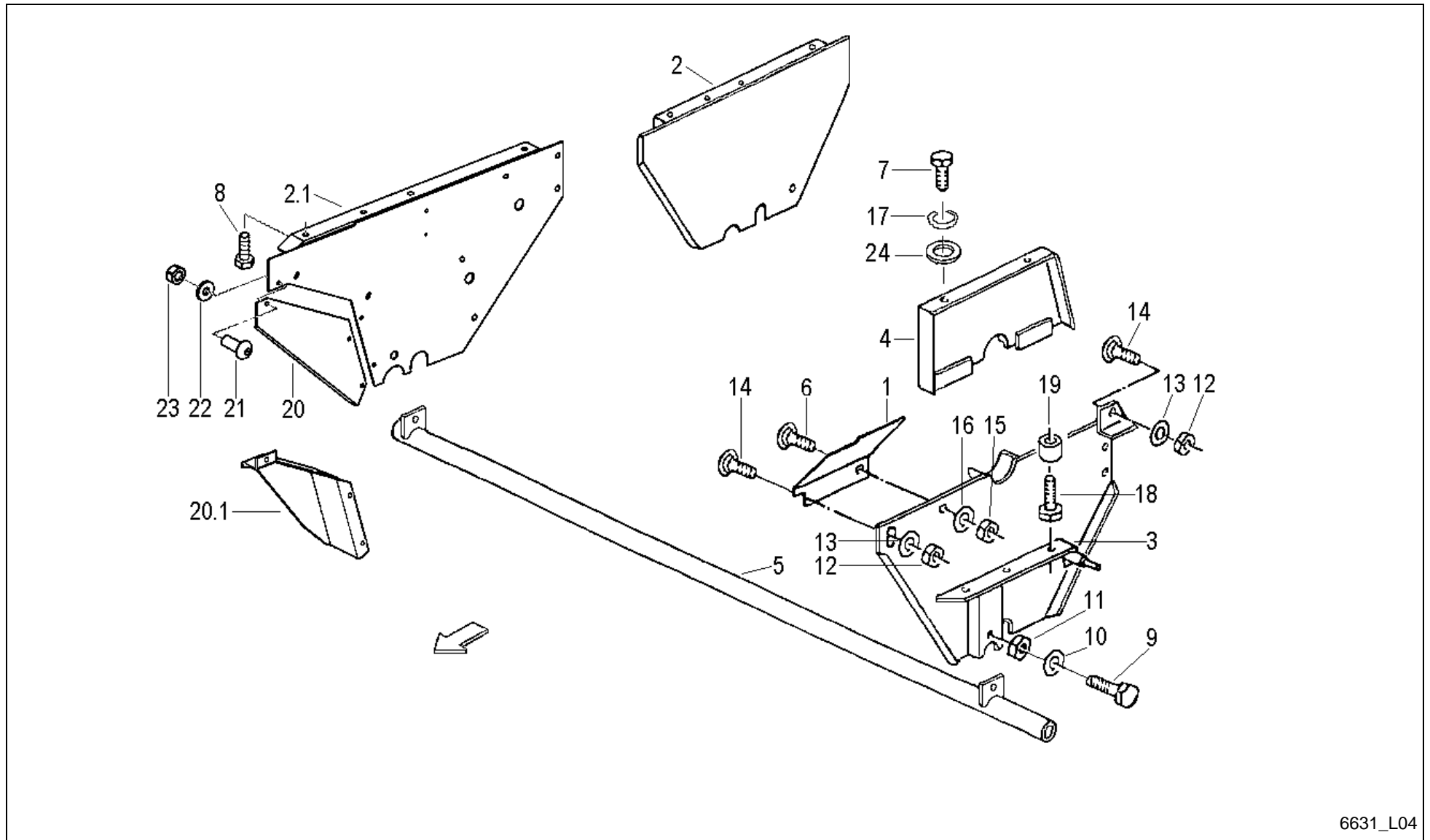

6631_L04

Feedex 360 T / DRUM ELEVATOR SIDE MEM. A. COV .SHEET



PosNo.	Part No.	Qty.	Description	Remark
1	VF06558937	1	SHEET	
2	VF06571198	1	SIDE MEMBER R	-A 2003, ersetzbar durch Pos.2.1+20
2.1	VF16631220	1	SIDE PANEL RIGHT WELDED	
3	VF06571196	1	SIDE MEMBER L	
4	VF06577389	1	COVERING SHEET	
5	VF06577391	1	CROSS TUBE	
6	VF01138989	1	TRUSS-HEAD SCREW	
7	VF01112407	2	HEX. HEAD SCREW	
8	VF06209459	4	SCREW M12X35D933 8.8 A3C DIN267-27 COATE	
9	VF01112709	2	HEX.BOLT	
10	VF01169697	2	RETAINING WASHER	
11	VF01112886	2	HEX. NUT	
12	VF06209768	2	LOCK NUT	
13	VF01107165	2	WASHER M10 11X20X2 A2C DIN126	
14	VF06207557	2	SAUCER HEAD SCREW	
15	VF01114357	1	LOCK NUT	
16	VF06214189	1	WASHER 6,4X18X2 A2C	
17	VF01102800	2	SPRING WASHER	
18	VF06209245	3	SCR. M12X50D931 10.9 GALV. DIN267-27	
19	VF06571325	3	SPACER RING	
20	A143047286	1	SIDE PLATE	für Pu 1.6
20.1	VF16631184	1	REFUSE PLATE	für Pu 1.8
21	VF01142565	3	TRUSS-HEAD SCR. M8X20 109 GALV.	
22	VF06214193	3	WASHER 8,4X21X3 GALV.	
23	VF01104944	3	NY LOCK NUT 8A3CD985	
24	VF06214198	2	WASHER	

Feedex 360 T / DRUM ELEVATOR DRUM 4- RAKE

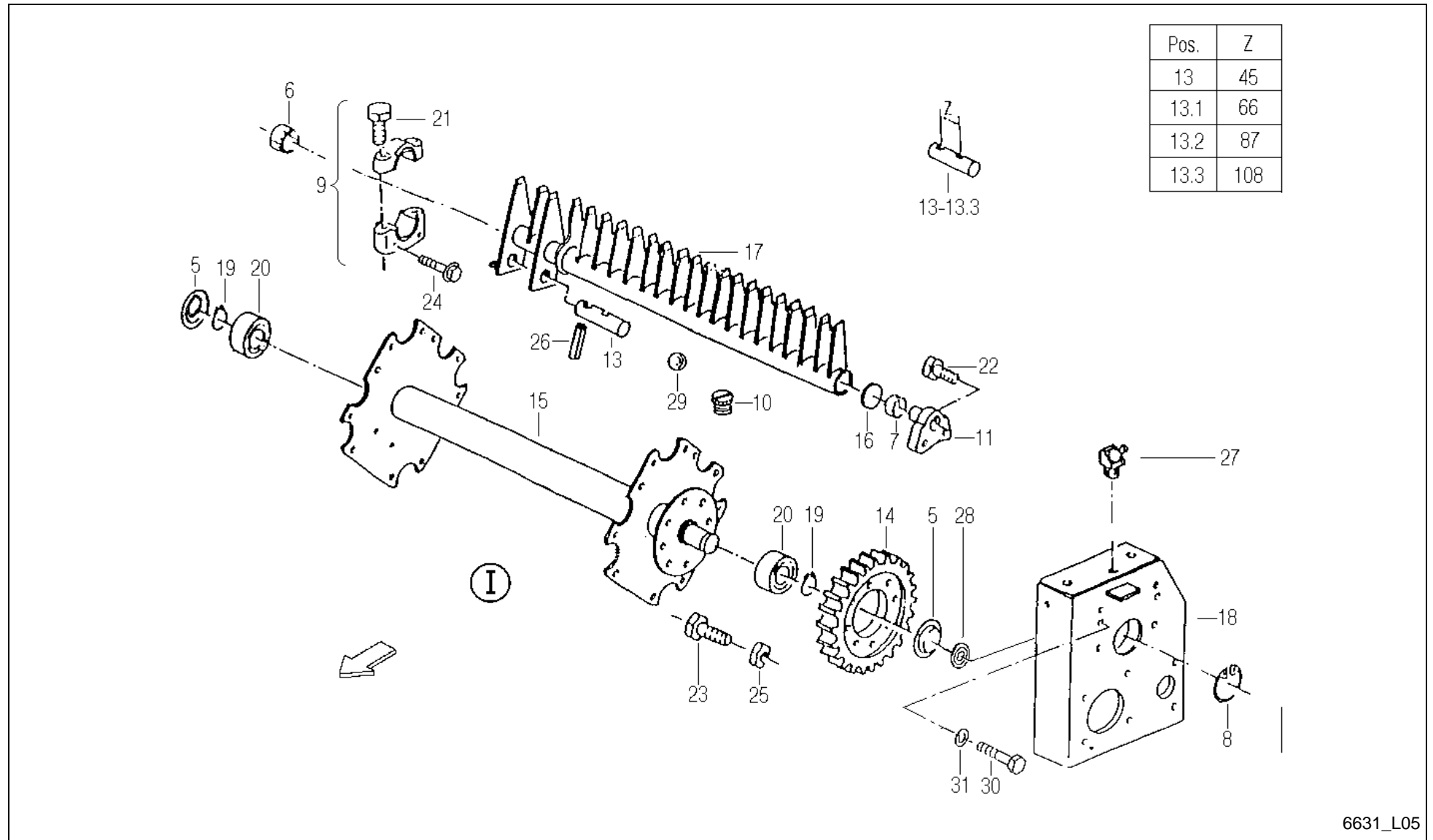

6631_L05



Feedex 360 T / DRUM ELEVATOR DRUM 4- RAKE

PosNo.	Part No.	Qty.	Description	Remark
1	A143031730	1	DRUM ELEVATOR	b L05/B+L06/B
5	VF06577317	2	CAP	
6	VF16515167	16	BEARING BRASS	
7	VF01142086	4	BUSH	
8	VF01107858	1	CIRCLIP	
9	VF16515168	4	BEARING/SUPPORT	
10	VF06216527	1	PROTECTING PLUG	
11	VF06571150	4	FLANGED PIN	
13	VF16516766	1	PIN/BOLT/STUD Z=45	
13.1	VF16516767	1	PIN/BOLT/STUD Z=66	
13.2	VF16516768	1	PIN/BOLT/STUD Z=87	
13.3	VF16516769	1	PIN/BOLT/STUD Z=108	
14	VF06577335	1	SPUR GEAR	
15	VF16516679	1	DRUM/REEL	
16	VF06578868	4	WASHER/DISC/PLATE	
17	VF16614454	4	RAKE	
18	VF16516664	1	SUPPORT PLATE	
19	VF01137321	2	RING	
20	VF01141159	2	ROLLER BEARING	
21	VF06273763	8	HEX. SCREW M12X60 I4014 8.8 A3C H2091	
22	VF06273771	8	HEX. SCREW M16X30 I4017 8.8 A3C H2091	
23	VF01112687	8	HEX. HEAD SCREW	
24	VF01142796	8	HEX.BOLT	
25	VF01127856	8	LOCK NUT	
26	VF01157381	4	DOWEL PIN	
27	VF01120696	2	GREASE NIPPLE H2 BM 6X1 DIN 71412	
28	VF16516754	1	RUBBER GROMMET	
29	VF01116946	4	BALL	
30	VF06273759	4	HEX. HEAD SCREW	
31	VF01142841	4	LOCKING WASHER	

Feedex 360 T / DRUM ELEVATOR DRUM 6 RAKE

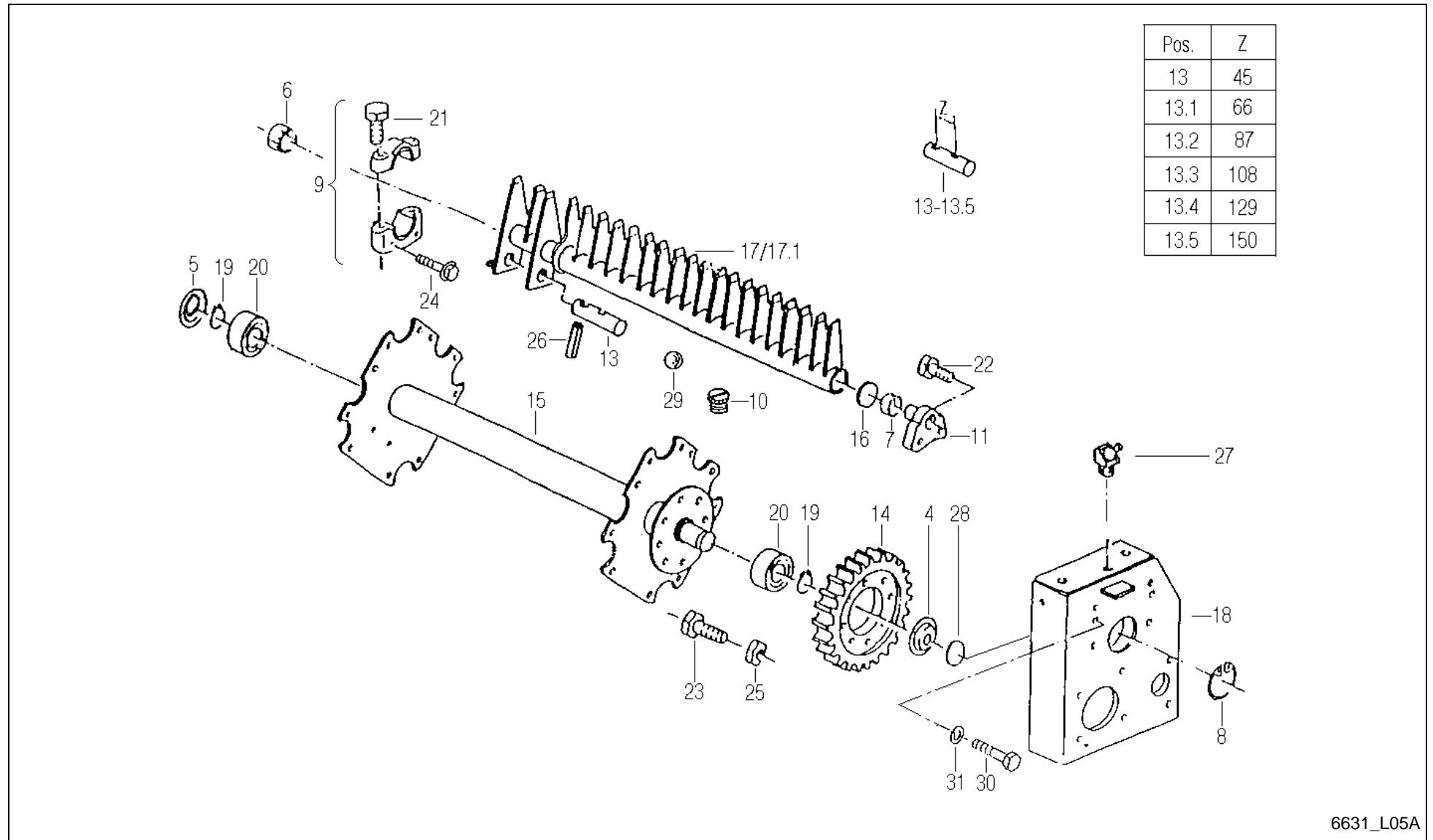



Feedex 360 T / DRUM ELEVATOR DRUM 6 RAKE

PosNo.	Part No.	Qty.	Description	Remark
4	VF16516663	1	COVER	
5	VF06577317	1	CAP	
6	VF16515167	24	BEARING BRASS	
7	VF01142086	6	BUSH	
8	VF01107858	1	CIRCLIP	
9	VF16515168	6	BEARING/SUPPORT	
10	VF06216527	1	PROTECTING PLUG	
11	VF06571150	6	FLANGED PIN	
13	VF16516653	1	PIN/BOLT/STUD	
13.1	VF16516654	1	STUEBOLZEN Z=66	
13.2	VF16516655	1	STUEBOLZEN Z=87	
13.3	VF16516656	1	STUEBOLZEN Z=108	
13.4	VF16516657	1	VALVE	
13.5	VF16516658	1	PIN/BOLT/STUD	
14	VF06577335	1	SPUR GEAR	
15	VF16513977	1	DRUM/REEL	
16	VF06578868	6	WASHER/DISC/PLATE	
17	VF16630142	3	RAKE WELDED	
17.1	VF16630143	3	RAKE WELDED	
18	VF16516664	1	SUPPORT PLATE	
19	VF01137321	2	RING	
20	VF01141159	2	ROLLER BEARING	
21	VF06273763	12	HEX. SCREW M12X60 I4014 8.8 A3C H2091	
22	VF06273771	12	HEX. SCREW M16X30 I4017 8.8 A3C H2091	
23	VF01112687	8	HEX. HEAD SCREW	
24	VF01142796	12	HEX.BOLT	
25	VF01127856	8	LOCK NUT	
26	VF01157381	6	DOWEL PIN	
27	VF01120696	2	GREASE NIPPLE H2 BM 6X1 DIN 71412	
28	VF16516754	1	RUBBER GROMMET	
29	VF01116946	6	BALL	
30	VF06273759	4	HEX. HEAD SCREW	
31	VF01142841	4	LOCKING WASHER	

Feedex 360 T / DRUM ELEVATOR DRUM 5 RAKE

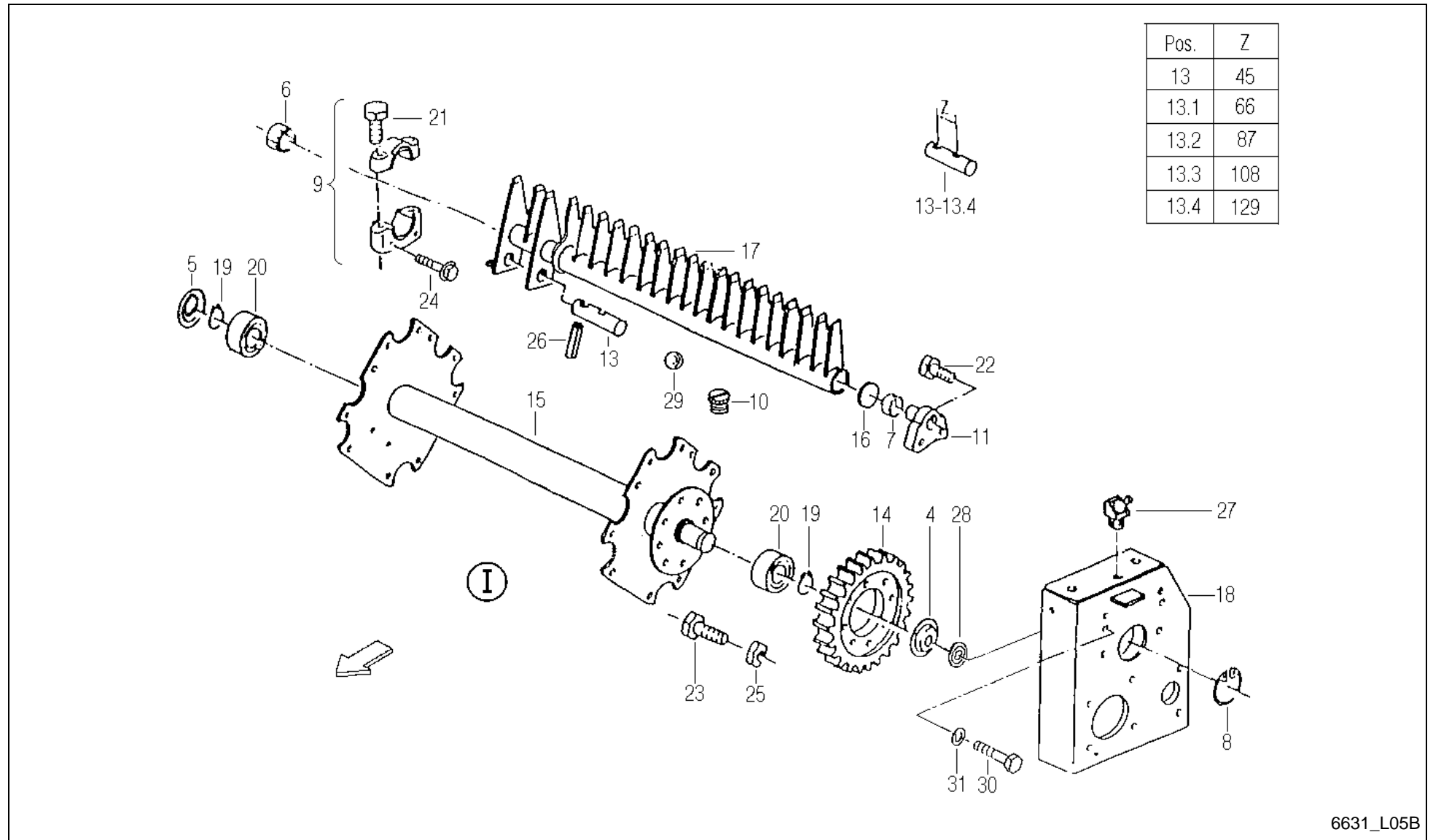



Feedex 360 T / DRUM ELEVATOR DRUM 5 RAKE

PosNo.	Part No.	Qty.	Description	Remark
1	A143031730	1	DRUM ELEVATOR	b L05/B+L06/B
4	VF16516663	1	COVER	
5	VF06577317	1	CAP	
6	VF16515167	20	BEARING BRASS	
7	VF01142086	5	BUSH	
8	VF01107858	1	CIRCLIP	
9	VF16515168	5	BEARING/SUPPORT	
10	VF06216527	1	PROTECTING PLUG	
11	VF06571150	5	FLANGED PIN	
13	VF16516653	1	PIN/BOLT/STUD	
13.1	VF16516654	1	STUEBOLZEN Z=66	
13.2	VF16516655	1	STUEBOLZEN Z=87	
13.3	VF16516656	1	STUEBOLZEN Z=108	
13.4	VF16516657	1	VALVE	
14	VF06577335	1	SPUR GEAR	
15	VF16631420	1	DRUM WELDED	
16	VF06578868	5	WASHER/DISC/PLATE	
17	VF16631920	5	RAKE WELDED	
18	VF16516664	1	SUPPORT PLATE	
19	VF01137321	2	RING	
20	VF01141159	2	ROLLER BEARING	
21	VF06273763	10	HEX. SCREW M12X60 I4014 8.8 A3C H2091	
22	VF06273771	10	HEX. SCREW M16X30 I4017 8.8 A3C H2091	
23	VF01112687	8	HEX. HEAD SCREW	
24	VF01142796	10	HEX.BOLT	
25	VF01127856	8	LOCK NUT	
26	VF01157381	5	DOWEL PIN	
27	VF01120696	2	GREASE NIPPLE H2 BM 6X1 DIN 71412	
28	VF16516754	1	RUBBER GROMMET	
29	VF01116946	5	BALL	
30	VF06273759	4	HEX. HEAD SCREW	
31	VF01142841	4	LOCKING WASHER	

Feedex 360 T / DRUM ELEVATOR CRANK WITH BEARING 4-RAKE

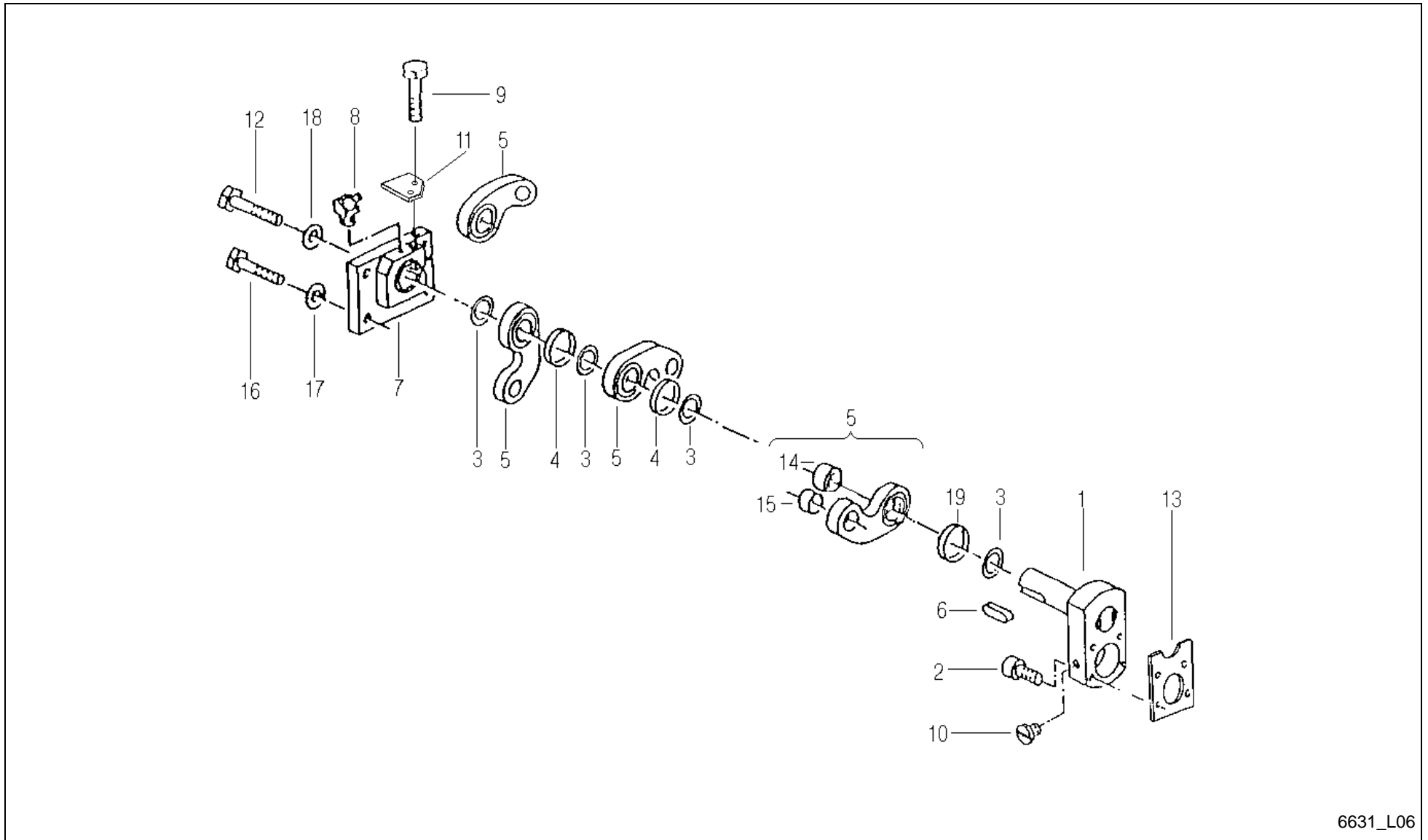

6631_L06

Feedex 360 T / DRUM ELEVATOR CRANK WITH BEARING 4-RAKE



PosNo.	Part No.	Qty.	Description	Remark
1	VF06577374	1	CRANK BEARING	
2	VF06273756	4	SOCKET HEAD SCREW	
3	VF06273873	7	NEEDLE BEARING	
4	VF06587559	5	SEAL RING	
5	VF16516750	4	AXLE LINK	
6	VF06277509	2	SUNK KEY	
7	VF16516772	1	FLANGE	
8	VF01120697	1	GREASE NIPPLE H2 BM 8X1 DIN 71412	
9	VF06273759	2	HEX. HEAD SCREW	
10	VF06216527	1	PROTECTING PLUG	
11	VF06577328	1	PLATE	
12	VF01139339	1	HEX.BOLT	
13	VF06553944	1	COVER	
14	VF06277518	4	BUSH 70W75X20-Y1-N2-C	
15	VF06277517	4	BEARING BUSH	
16	VF01143090	4	HEX.BOLT	
17	VF01142841	8	LOCKING WASHER	
18	A143047563	1	LOCKING WASHER	

Feedex 360 T / DRUM ELEVATOR CRANK WITH BEARING 6-RAKE

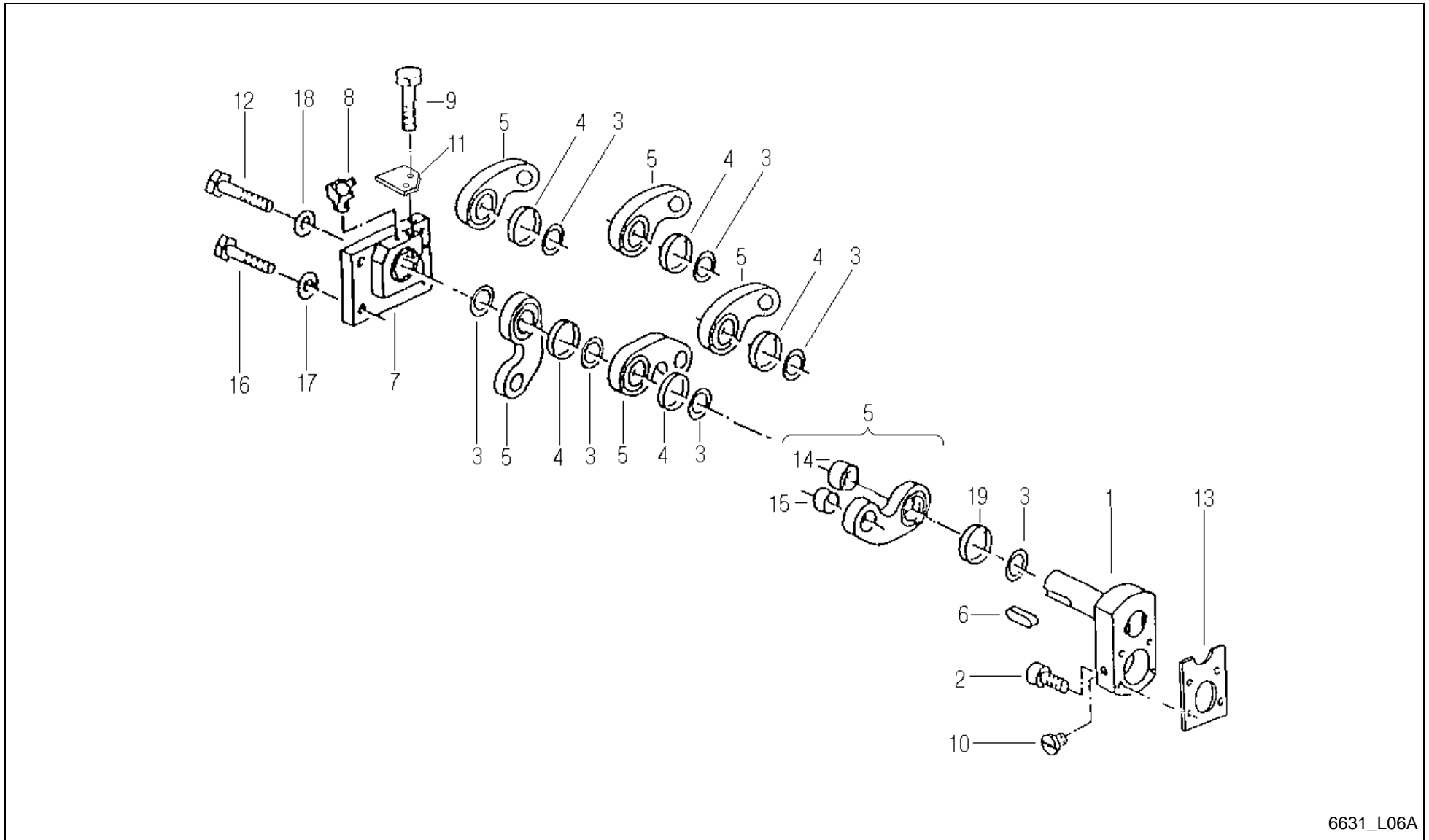

6631_L06A

Feedex 360 T / DRUM ELEVATOR CRANK WITH BEARING 6-RAKE



PosNo.	Part No.	Qty.	Description	Remark
1	VF16515089	1	CRANK BEARING	
2	VF06273756	4	SOCKET HEAD SCREW	
3	VF06273873	9	NEEDLE BEARING	
4	VF06587559	6	SEAL RING	
5	VF16516536	6	AXLE LINK	
6	VF06277509	2	SUNK KEY	
7	VF16516772	1	FLANGE	
8	VF01120697	1	GREASE NIPPLE H2 BM 8X1 DIN 71412	
9	VF06273759	2	HEX. HEAD SCREW	
10	VF06216527	1	PROTECTING PLUG	
12	VF16630549	1	HEXAGON HEAD SCREW M20X130 DIN931 10.9	
13	VF06553944	1	COVER	
14	VF16630146	6	BUSH	
15	VF06277517	6	BEARING BUSH	
16	VF16630548	4	HEXAGON HEAD SCREW M16X130 D931 10.9	
17	VF01142841	6	LOCKING WASHER	
18	A143047563	11	LOCKING WASHER	
19	VF16630145	1	SEAL RING	

Feedex 360 T / DRUM ELEVATOR CRANK WITH BEARING 5-RAKE

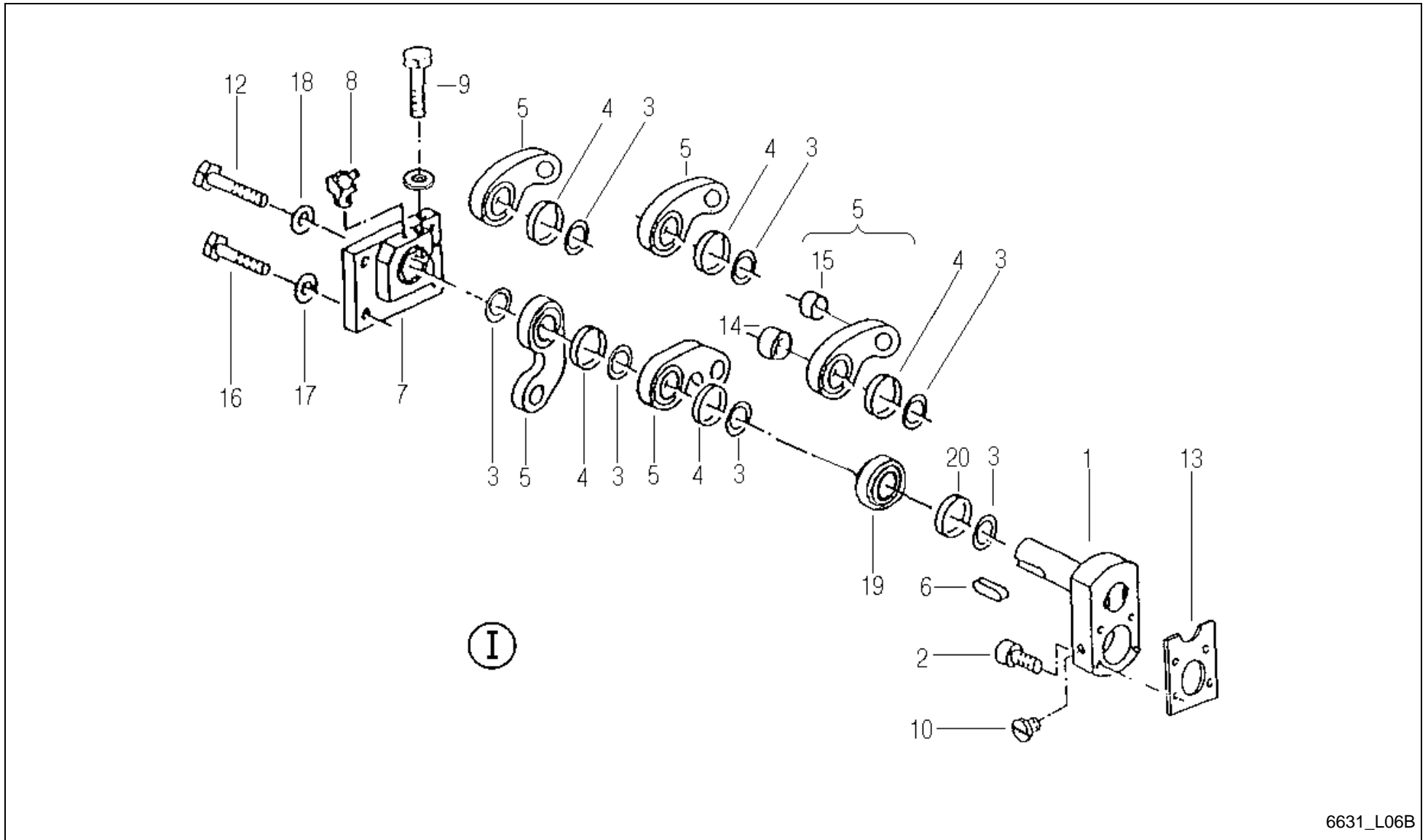

6631_L06B

Feedex 360 T / DRUM ELEVATOR CRANK WITH BEARING 5-RAKE



PosNo.	Part No.	Qty.	Description	Remark
1	A143031730	1	DRUM ELEVATOR	b L05/B+L06/B
1	VF16515089	1	CRANK BEARING	
2	VF06273756	4	SOCKET HEAD SCREW	
3	VF06273873	8	NEEDLE BEARING	
4	VF06587559	6	SEAL RING	
5	VF16631919	5	GUIDE	
6	VF06277509	2	SUNK KEY	
7	VF16516772	1	FLANGE	
8	VF01120697	1	GREASE NIPPLE H2 BM 8X1 DIN 71412	
9	VF06273759	2	HEX. HEAD SCREW	
10	VF06216527	1	PROTECTING PLUG	
12	VF01139339	1	HEX.BOLT	
13	VF06553944	1	COVER	
14	VF06277518	5	BUSH 70W75X20-Y1-N2-C	
15	VF06277517	5	BEARING BUSH	
16	VF01143090	4	HEX.BOLT	
17	VF01142841	4	LOCKING WASHER	
18	A143047563	1	LOCKING WASHER	
19	VF16631687	1	FEEDER COMB RING COMPLETE -	
20	VF16630145	1	SEAL RING	

Feedex 360 T / DRUM ELEVATOR PINION SHAFT

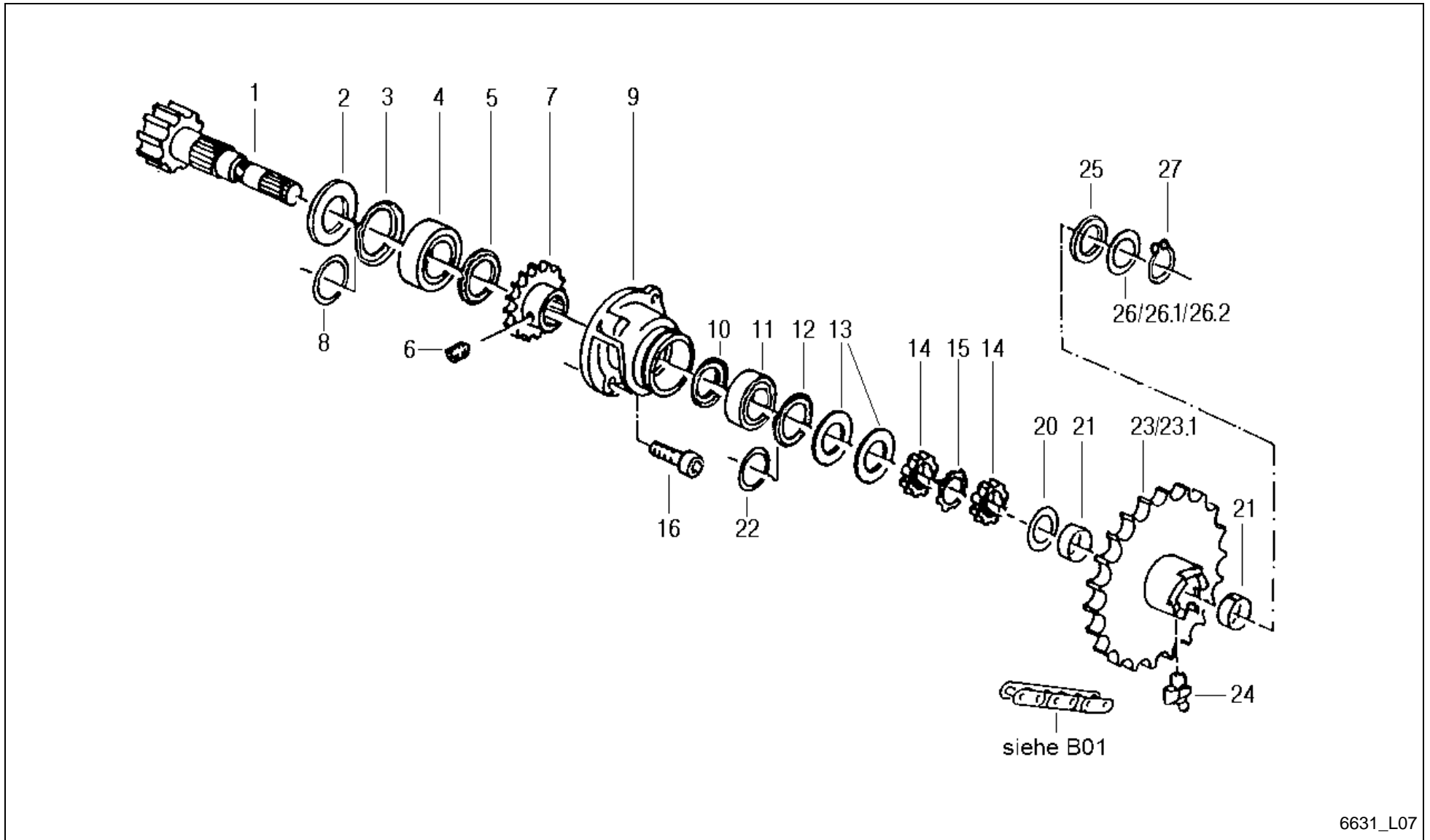



Feedex 360 T / DRUM ELEVATOR PINION SHAFT

PosNo.	Part No.	Qty.	Description	Remark
1	VF06571032	1	PINION SHAFT	
2	VF06571205	1	SEALING WASHER	
3	VF06214950	1	NILOS RING	
4	VF01109962	1	TAPER R. BEARING	
5	VF06273872	1	NILOS RING	
6	VF06208934	1	FITTING DIN 914 M 10X16 10.9=32 HRC	
7	VF06570914	1	CHAIN SPROCKET 3/4" - Z=19	
8	VF01137990	1	SPACER 60X75X1,0 D988	
9	VF06577305	1	BEARING HOUSING	
10	VF06273871	1	NILOS RING	
11	VF01109960	1	TAPER R. BEARING	
12	VF06214948	1	NILOS RING	
13	VF06570007	2	SEALING WASHER	
14	VF01120613	2	GROOVED NUT	
15	VF01120671	1	LOCKING PLATE	
16	VF01175657	4	SCR.M16X40D912 8.8 GALV.DIN267-27MKL	
20	VF06215016	1	THRUST WASHER AS 4565 45X65X1	
21	VF01139735	2	BUSH	
22	VF06214504	1	SPACER 50X62X1 D988	
23	VF06579358	1	HUB	+A 2006
23.1	VF16630151	1	HUB	-A 2005 für 6R, +A 2006 mit Pos. 23
24	VF01120700	1	GREASE FITT. 90DEGR. H3 CM 8X1 DIN 71412	
25	VF06571033	1	RING	
26	VF06214500	1	WASHER 45X55X1,0 DIN 988	
26.1	VF06214499	1	SPACER 45X55X0,5 D988	
26.2	VF01137130	1	SHIM 45X55X3 DIN988-2	
27	VF01124663	1	CIRCLIP	

Feedex 360 T / DRUM ELEVATOR RELEASE LEVER

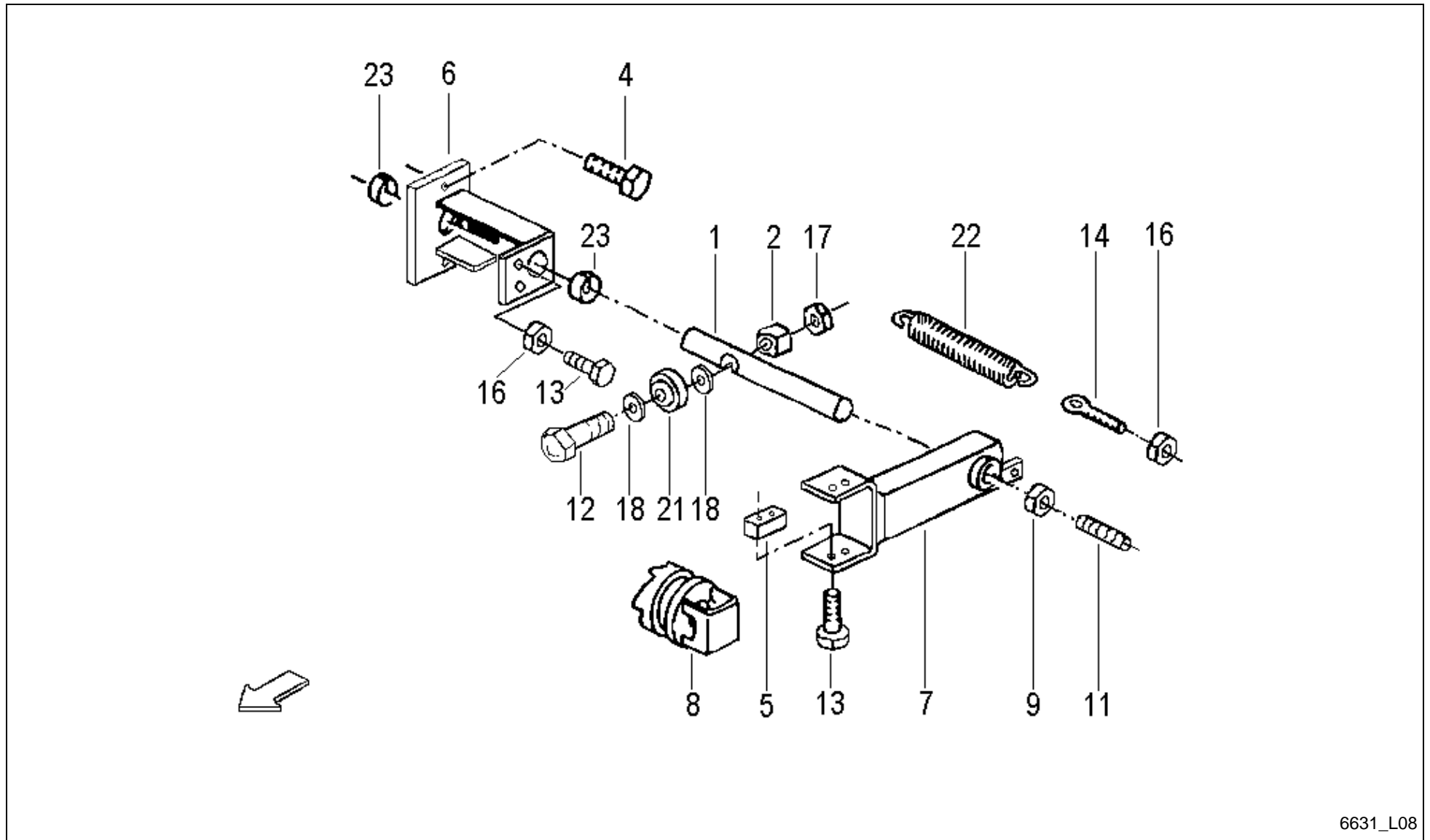

6631_L08



Feedex 360 T / DRUM ELEVATOR RELEASE LEVER

PosNo.	Part No.	Qty.	Description	Remark
1	VF06577348	1	PIN	
2	VF06577349	1	GUIDE PIECE	
4	VF06277504	2	HEX. HEAD SCREW	
5	VF06587560	1	SLIDE PIECE	
6	VF16630385	1	SUPPORT WITH BUSH	
7	VF06577385	1	DISCONN.FORK	
8	VF06556728	1	SLIDE CLATCH	
9	VF01137252	1	HEXNUT	
11	VF06208962	1	THREADED PIN	
12	KG00358261	1	HEX. BOLT M12X90 8.8	
13	VF01112333	6	HEX. HEAD SCREW	
14	VF01138951	1	EYE BOLT LBM 8X 50 DIN 444 - 4.6	
16	VF01112824	4	HEX. NUT	
17	VF06209769	1	LOCK NUT	
18	VF06214207	3	WASHER	
21	VF06215029	1	ROLLER LR 201 KRRU AH 01 12X35X15	
22	VF06215561	1	TENSION SPRING	
23	VF06277514	2	BUSH	

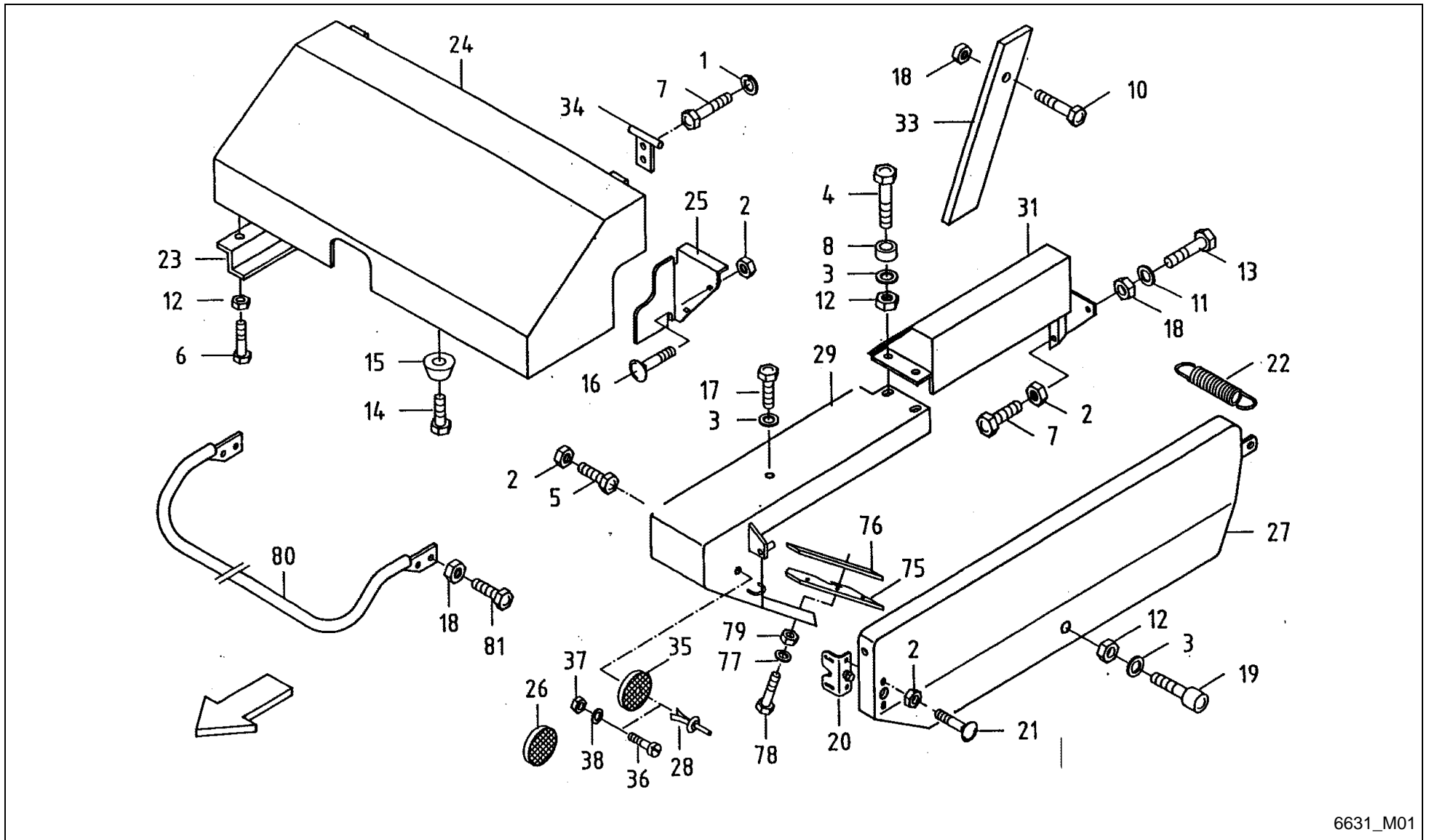

6631_M01

Feedex 360 T / PROT.HOOD



PosNo.	Part No.	Qty.	Description	Remark
1	VF01102799	4	SPRING WASHER	
2	VF01104944	10	NY LOCK NUT 8A3CD985	
3	VF06214189	7	WASHER 6,4X18X2 A2C	
4	VF01111079	2	HEX.BOLT	
5	VF01111153	1	HEX. HEAD SCREW	
5	VF01112322	1	HEX. HEAD SCREW	
6	VF01112240	3	HEX. HEAD SCREW	
7	VF01112307	6	HEX. HEAD SCREW	
8	VF16518913	2	PIPE/TUBE	
10	VF01112429	1	HEX. HEAD SCREW	
11	VF01107165	2	WASHER M10 11X20X2 A2C DIN126	
12	VF01114357	6	LOCK NUT	
13	VF01112407	1	HEX. HEAD SCREW	
14	VF01126049	2	SCREW	
15	VF01141112	2	RUBBER PAD	
16	VF01141006	2	TRUSS-HEAD SCR. M8X16 109 GALV.	
17	VF01103316	1	HEX. HEAD SCREW	
18	VF06209768	6	LOCK NUT	
19	VF01142826	1	RUBBER PAD	
20	VF16611457	1	LOCK	
21	VF01142565	2	TRUSS-HEAD SCR. M8X20 109 GALV.	
22	VF16613359	1	TENSION SPRING	
23	VF06556821	1	CROSS BAR	
24	A143031394	1	PROTECTION COVER	
25	VF06579350	1	COVER PLATE	
26	VF06214037	2	REFLEX, CIRCULAR YELLOW, ADHESIVE D60	
27	A143031894	1	PROTECTION COVER	
28	VF06214992	2	RIVET	
29	VF16611458	1	JACKET PLATE	
31	A143031994	1	COVERING SHEET	
33	VF06577514	1	SUPPORT	
34	VF06577521	2	HINGE	
35	VF06214036	2	REAR REFLECT.YELLOW	
36	VF01105593	4	CHEESE-HEAD SCREW	
37	VF06209765	2	LOCK NUT M5 8 GALV. DIN985	
38	VF06214189	2	WASHER 6,4X18X2 A2C	
75	VF16611397	1	RUBBER STRIP	
76	VF16611398	1	STRIP	
77	VF01107095	3	WASHER 6,4DIN125 GALV.	
78	VF01112264	3	HEX. HEAD SCREW	

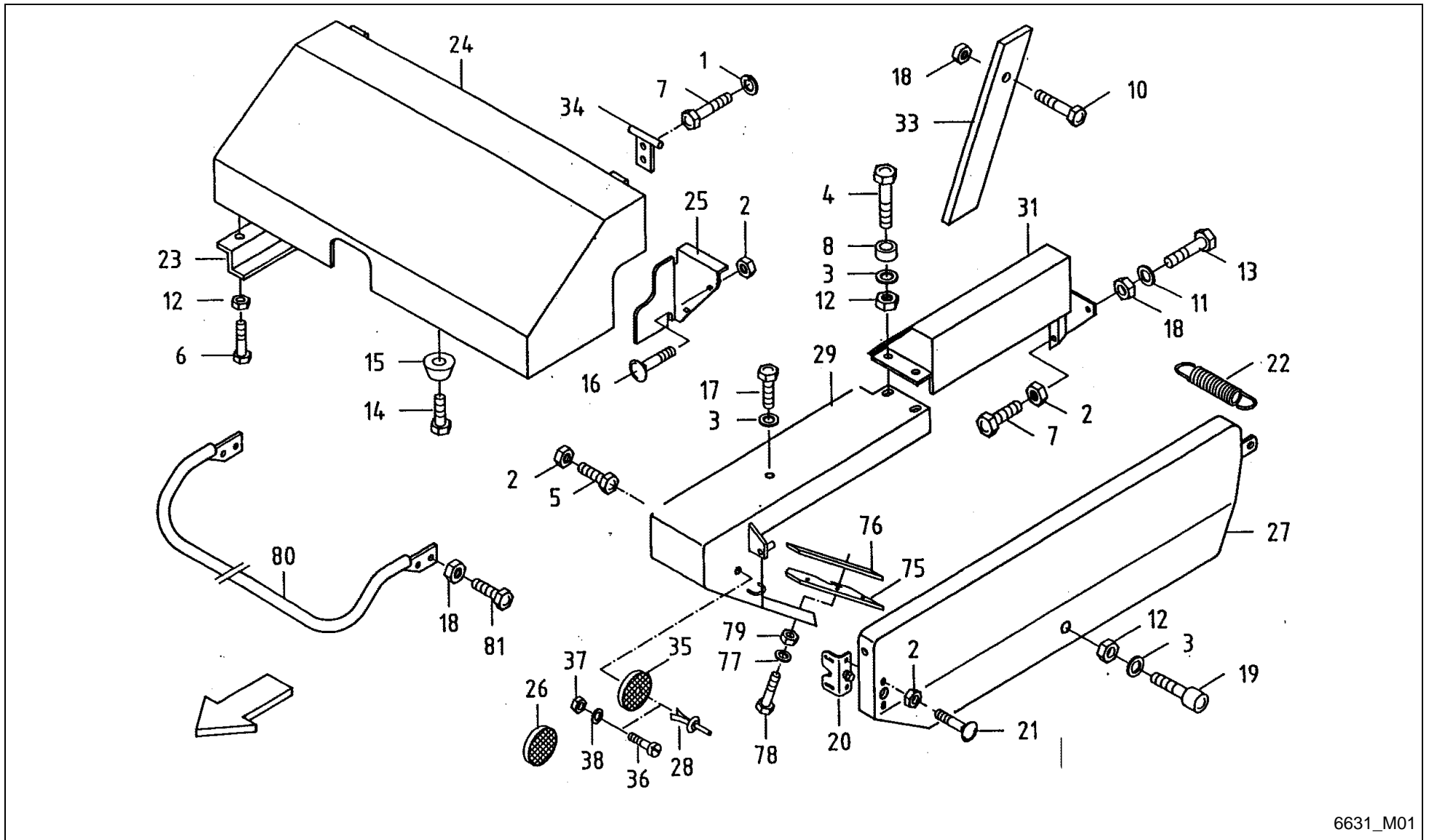

6631_M01

Feedex 360 T / PROT.HOOD



PosNo.	Part No.	Qty.	Description	Remark
79	VF01114357	3	LOCK NUT	
80	VF16611431	1	PROTECTIVE YOKE	-540
80	VF16630126	1	PROTECTIVE YOKE	+541
81	VF01112439	4	HEX. HEAD SCREW	

Feedex 360 T / MUDGUARD SMALL TANDEM AXLE

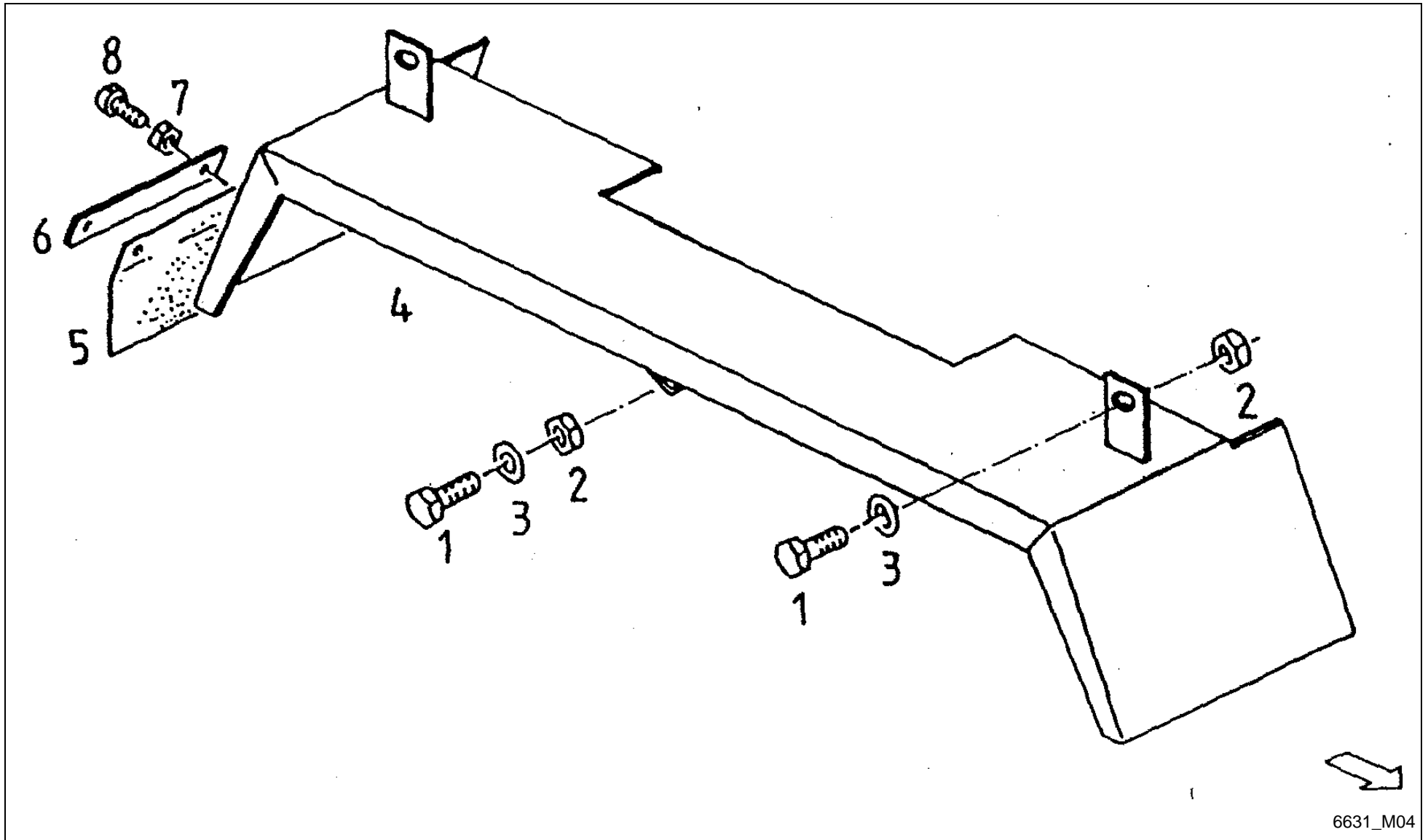

6631_M04

Feedex 360 T / MUDGUARD SMALL TANDEM AXLE



PosNo.	Part No.	Qty.	Description	Remark
1	VF01112439	8	HEX. HEAD SCREW	
2	VF06209768	8	LOCK NUT	
3	VF06214197	8	WASHER 10,5X30X3 GALV.	
4	VF16610586	2	MUDGUARD	
5	VF06577918	2	SUPPOR	
6	VF06577919	2	STRIP	
7	VF01114357	8	LOCK NUT	
8	VF01133784	8	CHEESE HEAD SCREW	

Feedex 360 T / MUDGUARD BROAD TANDEM AXLE

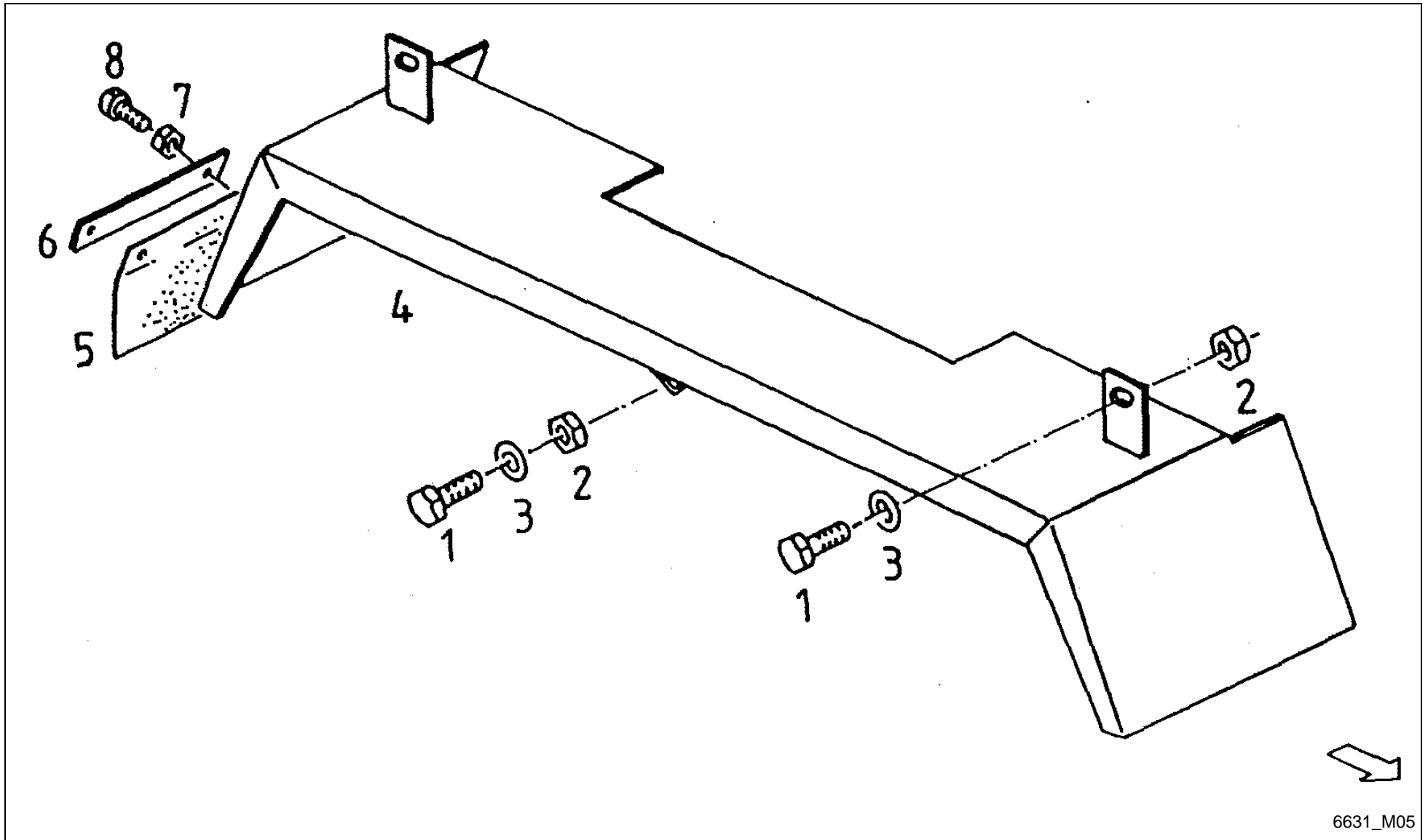

6631_M05

Feedex 360 T / MUDGUARD BROAD TANDEM AXLE



PosNo.	Part No.	Qty.	Description	Remark
1	VF01112439	8	HEX. HEAD SCREW	
2	VF06209768	8	LOCK NUT	
3	VF06214197	8	WASHER 10,5X30X3 GALV.	
4	VF16517079	2	MUDGUARD	
5	VF16516652	2	SUPPOR	
6	VF16516651	2	STRIP	
7	VF01114357	8	LOCK NUT	
8	VF01133784	8	CHEESE HEAD SCREW	

Feedex 360 T / CUTTING DEVICE

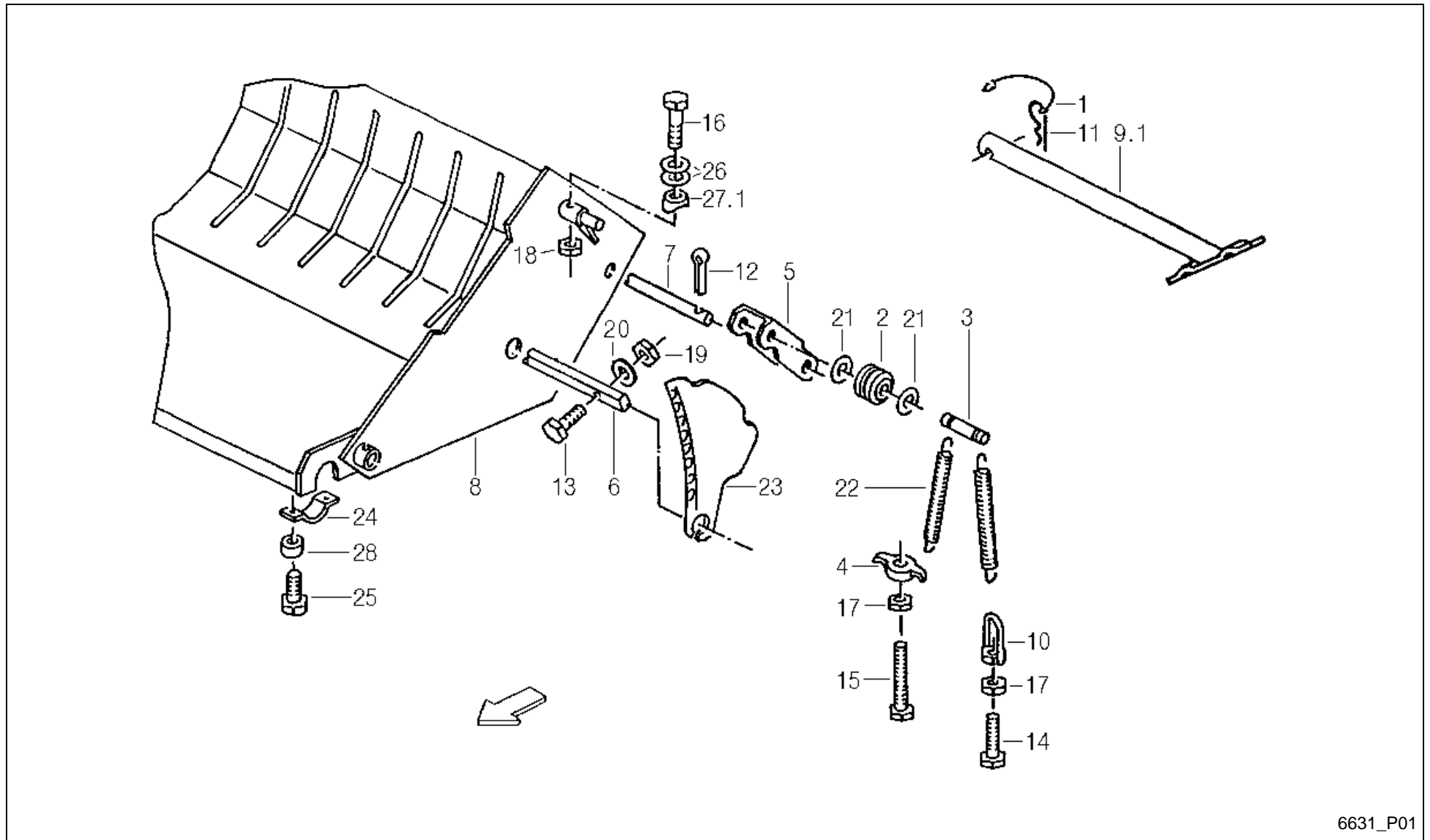

6631_P01



Feedex 360 T / CUTTING DEVICE

PosNo.	Part No.	Qty.	Description	Remark
1	VF06564448	1	CORD L= 240 COLOUR BLACK	
2	VF06577109	17	ROLLER	
3	VF06577110	17	PIN	
4	VF06577111	16	TIGHTENING PLATE	
5	VF06577442	17	YOKE	
6	VF16511336	1	AXLE	
7	VF06577583	1	AXLE	
8	VF06571172	1	CUTTING DEVICE	
9.1	VF16631279	1	RELEASE LEVER	+A 2005
10	VF06577496	2	NUT	
11	VF06264206	1	SPRING	
12	VF01106451	18	SPLIT PIN	
13	VF01112439	16	HEX. HEAD SCREW	
14	VF01112451	2	HEX. HEAD SCREW	
15	VF01112476	16	HEX. HEAD SCREW	
16	VF01111522	2	HEX. BOLT	
17	VF01102659	18	HEX. NUT	
18	VF06209769	2	LOCK NUT	
19	VF06209768	16	LOCK NUT	
20	VF01127538	16	WASHER	
21	VF06214206	34	WASHER 13X30X4 RM=580-680 MPA A2C	
22	VF06215561	34	TENSION SPRING	
23	VF06278720	17	KNIFE	
24	VF06578892	2	YOKE/RETAINER	
25	VF01177466	4	SCR.M10X30D933 8.8 GALV.DIN267-27MKL	
26	VF06214207	10	WASHER	
27.1	VF16606401	2	SHIM	
28	VF06562016	4	WASHER	

Feedex 360 T / DOUBLE-CHOPM EQUIPERN.

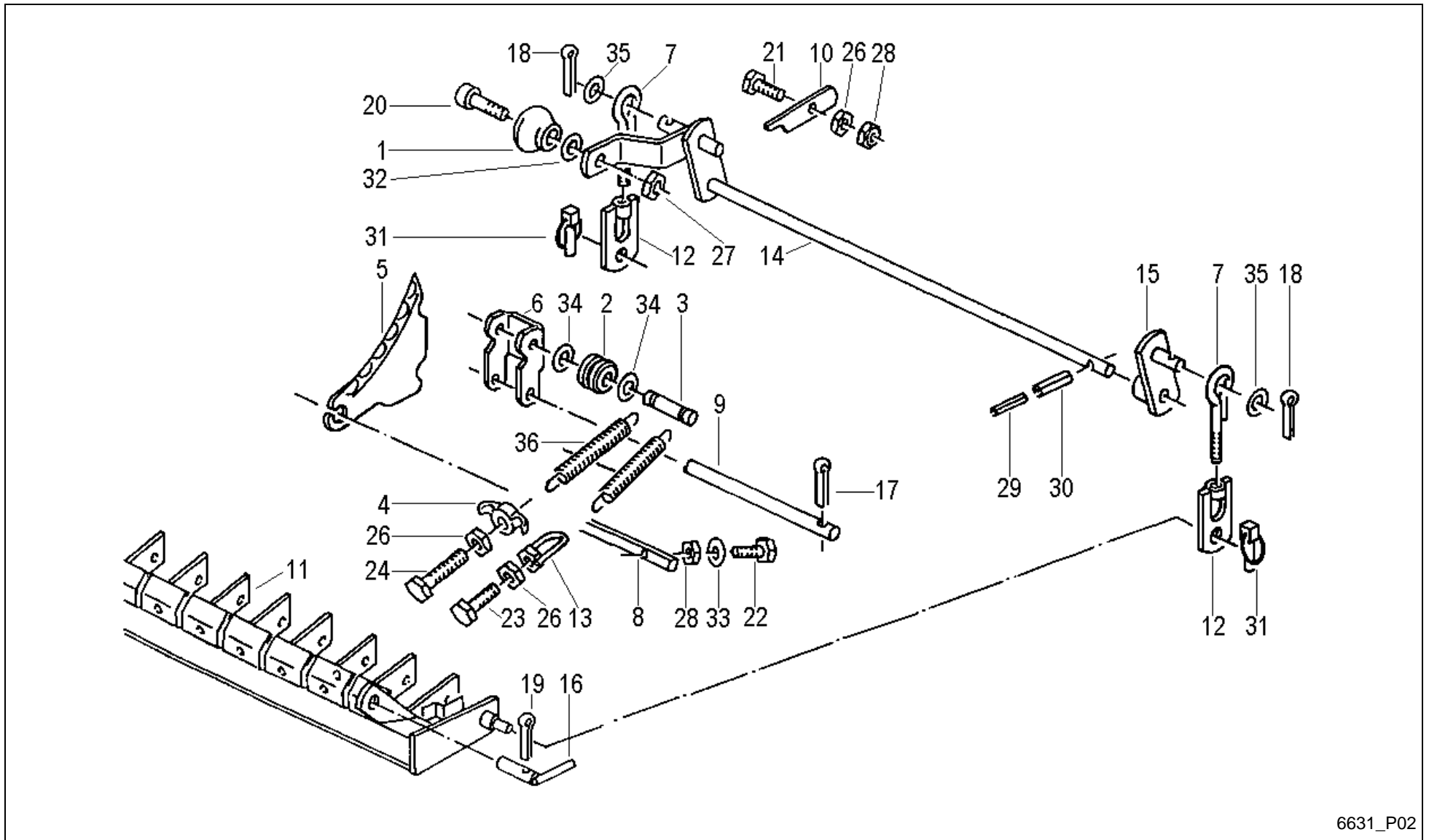

6631_P02

Feedex 360 T / DOUBLE-CHOPM EQUIPERN.



PosNo.	Part No.	Qty.	Description	Remark
1	VF06243750	1	BALL	
2	VF06577109	16	ROLLER	
3	VF06577110	16	PIN	
4	VF06577111	16	TIGHTENING PLATE	
5	VF06278720	16	KNIFE	
6	VF06577442	16	YOKE	
7	VF06577483	2	EYEBOLT	
8	VF16511337	1	KNIFE AXLE	
9	VF06577586	1	AXLE	
10	VF06577489	1	FLAT CATCH	
11	VF06571186	1	SUPPORT	
12	VF06577494	2	TRACTION EYE	
13	VF06577496	2	NUT	
14	VF06570195	1	TORSION ROD	
15	VF06570185	1	LEVER	
16	VF06577498	2	FIXING PIN	
17	VF01106451	16	SPLIT PIN	
18	VF01122072	2	SPLIT PIN	
19	VF01143009	2	SPLIT PIN	
20	VF01101405	1	SCREW	
21	VF01112429	1	HEX. HEAD SCREW	
22	VF01112439	15	HEX. HEAD SCREW	
23	VF01112451	2	HEX. HEAD SCREW	
24	VF01112476	16	HEX. HEAD SCREW	
26	VF01102659	18	HEX. NUT	
27	VF01104944	1	NY LOCK NUT 8A3CD985	
28	VF06209768	16	LOCK NUT	
29	VF01157344	1	DOWEL PIN	
30	VF01138412	1	DOWEL PIN	
31	VF01126332	2	DOWEL PIN	
32	VF01138374	1	WASHER	
33	VF01107165	15	WASHER M10 11X20X2 A2C DIN126	
34	VF06214206	32	WASHER 13X30X4 RM=580-680 MPA A2C	
35	VF06214226	2	WASHER	
36	VF06215561	32	TENSION SPRING	

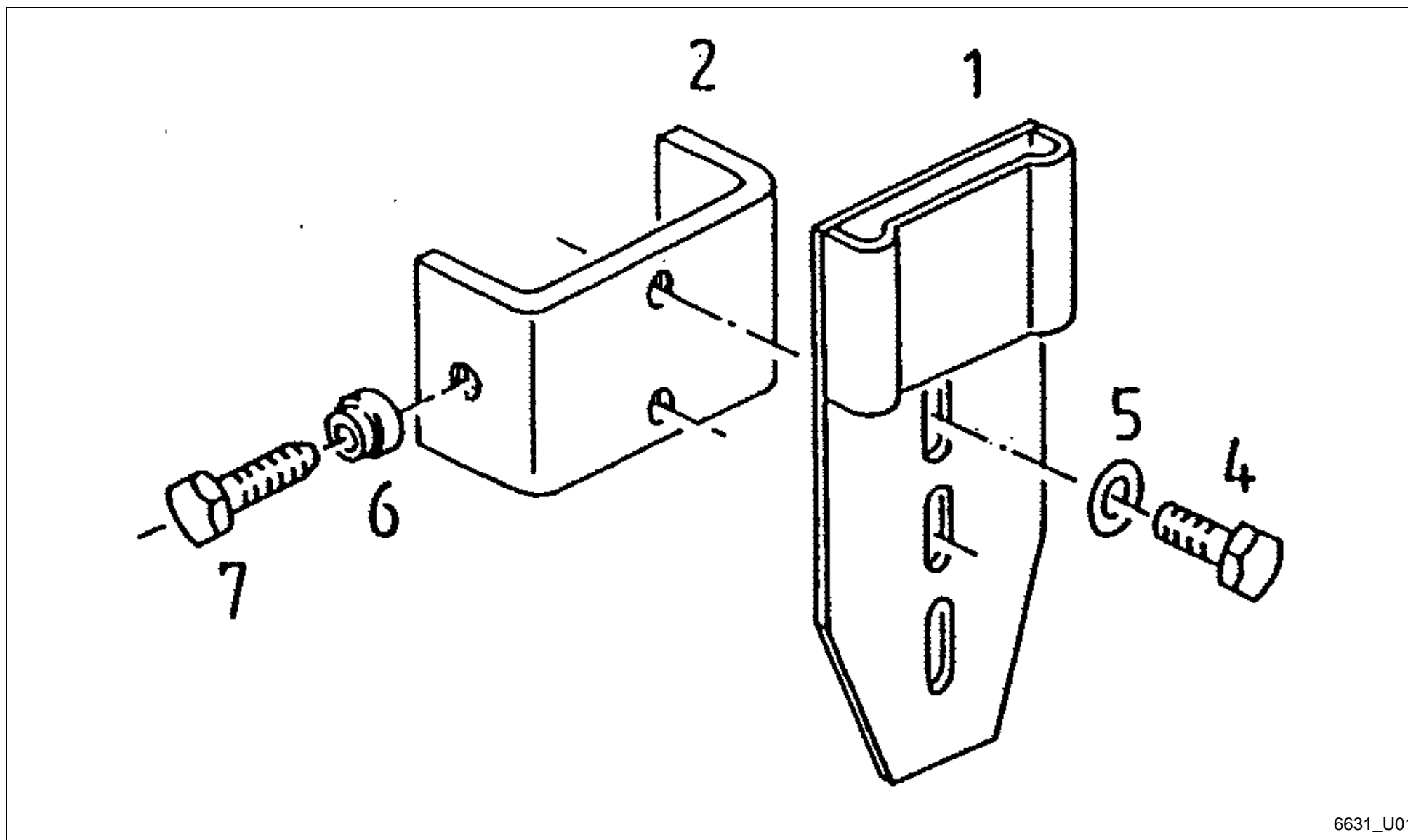

6631_U01

Feedex 360 T / INSTRUMENT BOARD FOR TÉLÉ COMMAND.



PosNo.	Part No.	Qty.	Description	Remark
1	VF06570724	1	SUPPORT	
2	VF06570740	1	YOKE	
4	VF01126186	2	HEX. HEAD SCREW	
5	VF01127538	2	WASHER	
6	VF01139650	1	THRUST PIECE	X 2
7	VF01142049	1	PRESSURE SCREW	X 2

Feedex 360 T / WARNING DECAL EU

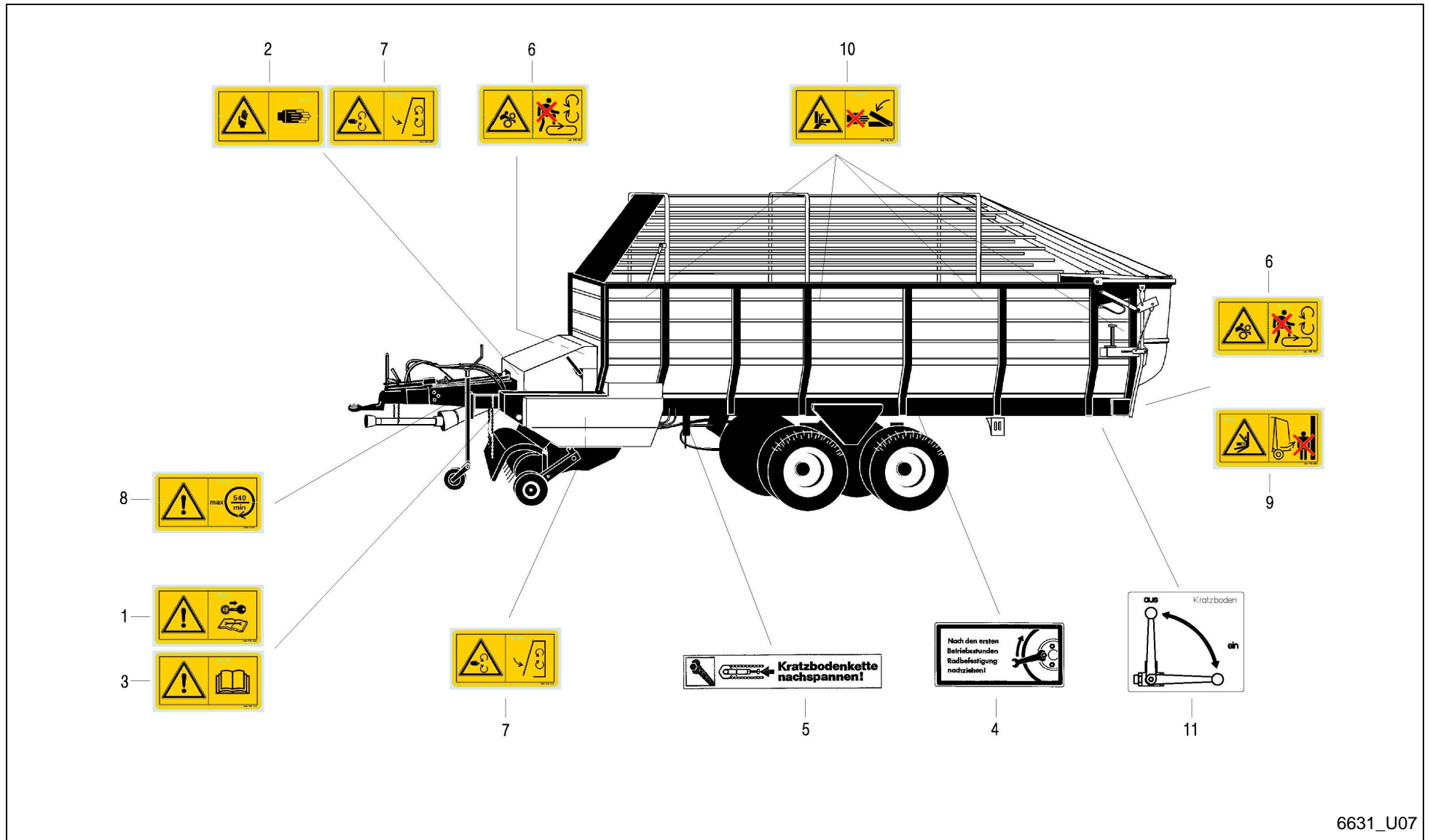

6631_U07

Feedex 360 T / WARNING DECAL EU



PosNo.	Part No.	Qty.	Description	Remark
1	VF16601350	1	WARNING DECAL SWITCH OF THE ENGINE	
2	VF16613392	1	WARNING PLATE	
3	VF16613391	1	WARNING DECAL READ OPENING MANUAL	
4	VF06216097	1	MARKING PLATE	
5	A143019674	1	STICKER CHAIN TIGHTEN	
6	VF16613390	2	WARNING PLATE	
7	VF16613728	3	WARNSCHILD	
8	VF16601375	1	WARNING DECAL MAX. 540 RPM	
9	VF16613719	8	WARNING DECAL RISK OF CRUSHING	
10	VF16613389	1	AUFKLEBER WARNSCHILD .	
11	A143019774	1	STICKER HANDLING SCRAPER FLOOR	

Feedex 360 T / DECALS

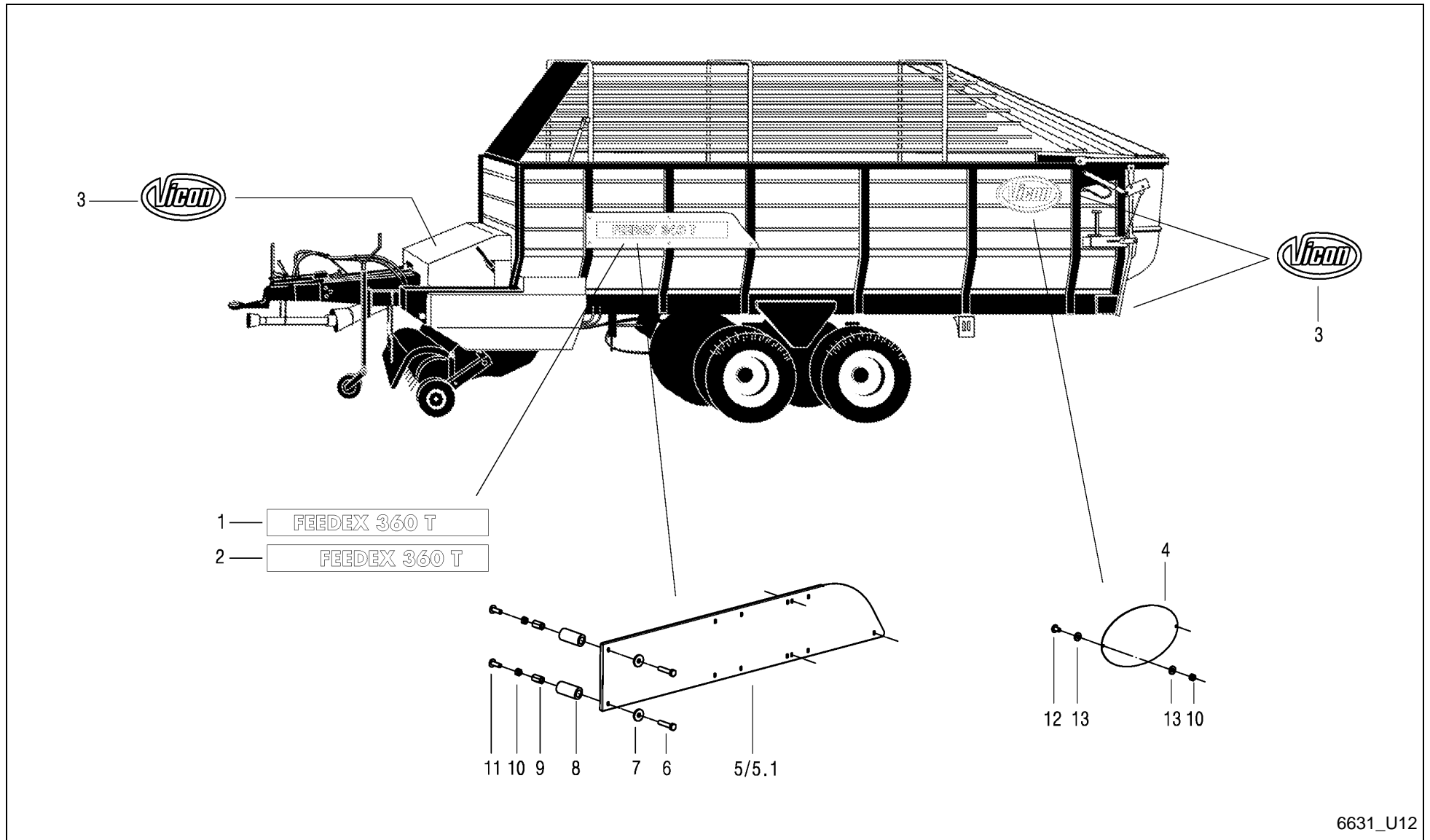

Feedex 360 T / DECALS



PosNo.	Part No.	Qty.	Description	Remark
1	A143042374	1	STICKER FEEDEX 360 T LEFT	
2	A143042474	1	STICKER FEEDEX 360 T RIGHT	
3	A143008974	4	STICKER VICON LOGO (MEDIUM-SIZED)	
4	A143009094	2	FITTING PANEL VICON_1	
5	A143017094	1	SHEET 1 LEFT	
5.1	A143017194	1	SHEET 2 RIGHT	
6	VF01112356	1	BOLT M8X40 ISO4017 8.8 A3C (D933)	
7	VF06214192	10	WASHER 8,4X25X3 GALV.	
8	A143017286	10	SPACER TUBE	
9	A143017300	10	EXTENSION NUT	
10	VF01104944	14	NY LOCK NUT 8A3CD985	
11	VF01142856	10	CUP SQR. BOLT M8X25DIN7380-2 10.9 GALV.	
12	VF01141006	4	TRUSS-HEAD SCR. M8X16 109 GALV.	
13	VF06214358	8	WASHER	

Feedex 360 T / Part No Index



Part No.	Page	Pos No	Part No.	Page	Pos No	Part No.	Page	Pos No	Part No.	Page	Pos No
A10000300	4	14	A143031894	91	27	A143458700	22	65	A143504300	21	60
A10000300	5	14	A143031994	91	31	A143459000	21	62	A143504300	22	55
A143008974	98	3	A143032194	47	47	A143466900	59	437	A143504400	21	61
A143009094	98	4	A143032194	48	47	A143466900	59	450	A143504500	21	64
A143012000	45	1	A143032294	47	48	A143467500	59	451	A143504700	21	65
A143012100	45	2	A143032294	48	48	A143472600	21	63	A143504700	22	46
A143012200	45	3	A143032394	48	49.1	A143472600	22	50	A143504800	21	66
A143012300	45	4	A143032494	48	49.2	A143472600	59	448	A143504900	21	67
A143012400	45	5	A143032594	48	50.1	A143475200	19	61	A143504900	22	51
A143012500	45	6	A143032694	48	50.2	A143475200	20	61	A143505000	21	68
A143012600	45	7	A143032794	47	51	A143485300	59	438	A143505000	22	48
A143012700	45	8	A143032794	48	51	A143485400	21	23	A143505200	21	69
A143012800	45	9	A143032894	47	52	A143485400	22	23	A143505200	22	47
A143012900	45	10	A143032894	48	52	A143501400	35	23.2	A143505500	21	71
A143013000	45	11	A143032994	47	53	A143501900	5	16	A143505500	22	60
A143013100	45	12	A143032994	48	53	A143502000	4	16	A143505800	21	77
A143014300	12	14	A143033094	47	54	A143502900	20	1	A143505800	22	63
A143014600	12	13	A143033094	48	54	A143503000	19	28	A143505900	21	81
A143014600	12	13.1	A143037800	12	15	A143503000	20	28	A143505900	22	68
A143015000	67	33.1	A143037800	12	15.1	A143503100	19	38	A143506000	21	82A
A143017094	98	5	A143039786	10	15	A143503100	20	38	A143506100	21	84
A143017194	98	5.1	A143039830	18	1	A143503200	20	43	A143506100	22	84
A143017286	98	8	A143042374	98	1	A143503300	19	53	A143506200	21	91
A143017300	98	9	A143042474	98	2	A143503300	20	53	A143506200	22	91
A143019674	97	5	A143043000	27	26	A143503400	19	59	A143506300	21	1
A143019774	97	11	A143043000	30	21	A143503400	20	59	A143506400	21	26
A143030430	72	1	A143043186	30	15	A143503600	19	72	A143506400	22	26
A143031394	91	24	A143046200	27	3	A143503600	20	72	A143506500	21	52
A143031594	49	44	A143047286	82	20	A143503700	19	92	A143506500	22	52
A143031663	11	26	A143047563	86	18	A143503700	20	92	A143506600	21	53
A143031730	83	1	A143047563	87	18	A143503800	21	96	A143506600	22	53
A143031730	85	1	A143047563	88	18	A143503800	22	96	A143506700	22	1
A143031730	88	1	A143458700	21	75	A143503800	23	96	A143506800	22	22

Feedex 360 T / Part No Index



Part No.	Page	Pos No	Part No.	Page	Pos No	Part No.	Page	Pos No	Part No.	Page	Pos No
A143506900	22	57	KG00476561	4	13	VF01102659	60	12	VF01104944	28	22
A143507000	22	58	KG00476561	5	13	VF01102659	94	17	VF01104944	37	10
A143507100	23	91	KG00480461	1	15	VF01102659	95	26	VF01104944	42	20
A143507200	23	1	KG00742063	4	52	VF01102664	29	26	VF01104944	46	4
A143507300	19	1	KG00742063	5	52	VF01102664	30	26	VF01104944	47	19
A143507400	19	43	KG01184962	24	11	VF01102701	46	18	VF01104944	48	6
A143507600	21	25	KG01184962	25	11	VF01102796	64	22	VF01104944	49	36
A143507600	22	25	KG01185862	17	5	VF01102797	43	3	VF01104944	50	16
A143507700	21	32	KG01194500	4	27	VF01102797	44	3	VF01104944	51	29
A143507700	22	32	KG01194500	5	27	VF01102797	45	15	VF01104944	52	4
A143507700	23	32	KG01248161	58	17	VF01102797	50	61	VF01104944	53	8
A143517100	59	473	KG01273861	36	1	VF01102797	64	14	VF01104944	55	11
A143517400	59	400	KG01273861	75	45	VF01102799	2	29	VF01104944	57	11
A143517500	59	414	VF01001718	54	15	VF01102799	60	8	VF01104944	63	3
A143517600	59	414A	VF01097625	57	21	VF01102799	66	28	VF01104944	66	23
A143517700	59	416	VF01100233	37	21	VF01102799	91	1	VF01104944	67	45
A143517800	59	417	VF01100590	55	19	VF01102800	2	23	VF01104944	68	13
A143517900	59	422	VF01100590	57	22	VF01102800	3	17	VF01104944	68	7
A143518000	59	472	VF01100600	24	16	VF01102800	28	16	VF01104944	70	7
A143518100	59	424	VF01100600	25	16	VF01102800	82	17	VF01104944	71	29
A143518200	59	425	VF01100982	43	30	VF01103117	42	7	VF01104944	72	29
A143518300	59	433	VF01100982	44	34	VF01103316	29	23	VF01104944	73	7
A143518400	59	435	VF01100982	45	25	VF01103316	30	23	VF01104944	76	7
A143518500	59	436	VF01101288	24	18	VF01103316	42	9	VF01104944	77	8
A143518600	59	440	VF01101288	25	18	VF01103316	47	80	VF01104944	79	3
A143518700	59	442	VF01101405	95	20	VF01103316	52	11	VF01104944	80	3
A143518800	59	446	VF01101596	7	11	VF01103316	64	16	VF01104944	81	3
A143518900	59	447	VF01101596	9	8	VF01103316	91	17	VF01104944	82	23
A143519000	59	449	VF01101600	62	17.1	VF01103341	24	21	VF01104944	91	2
A143519100	59	470	VF01102550	64	5	VF01103341	25	21	VF01104944	95	27
A143519200	59	471	VF01102659	8	19	VF01103341	31	2	VF01104944	98	10
KG00357500	15	14	VF01102659	11	30	VF01103341	41	13	VF01105524	64	7
KG00358261	90	12	VF01102659	49	27	VF01104944	12	22	VF01105526	64	21

Feedex 360 T / Part No Index



Part No.	Page	Pos No	Part No.	Page	Pos No	Part No.	Page	Pos No	Part No.	Page	Pos No
VF01105544	66	13	VF01107163	63	2	VF01108524	68	16	VF01111298	66	16
VF01105571	63	35	VF01107163	66	27	VF01108524	70	12	VF01111298	69	36
VF01105593	91	36	VF01107163	74	26	VF01108524	73	16	VF01111308	15	12
VF01106447	13	5	VF01107163	79	15	VF01108524	76	12	VF01111315	75	36
VF01106447	37	3	VF01107163	80	15	VF01108981	3	11	VF01111325	8	16
VF01106451	11	24	VF01107163	81	15	VF01108982	67	21	VF01111336	60	10
VF01106451	24	9	VF01107165	16	5	VF01109044	3	13	VF01111339	16	2
VF01106451	25	9	VF01107165	28	24	VF01109057	3	12	VF01111352	28	18
VF01106451	35	29	VF01107165	66	20	VF01109063	2	14	VF01111475	11	38
VF01106451	36	7	VF01107165	68	12	VF01109886	17	13	VF01111486	16	27
VF01106451	41	3	VF01107165	69	38	VF01109958	2	15	VF01111504	58	30
VF01106451	49	3	VF01107165	75	38	VF01109960	89	11	VF01111514	49	5
VF01106451	52	6	VF01107165	82	13	VF01109962	89	4	VF01111522	94	16
VF01106451	58	35	VF01107165	91	11	VF01110001	7	12	VF01111527	49	22
VF01106451	60	29	VF01107165	95	33	VF01110001	9	7	VF01111562	11	15
VF01106451	94	12	VF01107726	67	18	VF01110002	2	16	VF01111576	53	4
VF01106451	95	17	VF01107726	71	14	VF01110415	2	17	VF01111861	11	5
VF01106500	39	6	VF01107726	72	14	VF01110415	3	20	VF01111867	55	10
VF01106500	61	12	VF01107737	1	6	VF01110577	66	14	VF01111867	57	10
VF01107095	50	60	VF01107742	67	19	VF01111071	16	18	VF01111941	18	2
VF01107095	65	5	VF01107742	71	19	VF01111071	24	25	VF01112240	62	25
VF01107095	91	77	VF01107742	72	19	VF01111071	25	25	VF01112240	91	6
VF01107101	58	16	VF01107755	1	28	VF01111071	65	4	VF01112264	34	22
VF01107103	34	9	VF01107760	67	20	VF01111079	91	4	VF01112264	36	70
VF01107105	50	44	VF01107792	69	63	VF01111083	52	18	VF01112264	64	26
VF01107105	60	11	VF01107792	75	63	VF01111136	74	21	VF01112264	66	18
VF01107121	35	28	VF01107838	70	4	VF01111153	91	5	VF01112264	74	28
VF01107158	65	16	VF01107838	76	4	VF01111168	40	14	VF01112264	91	78
VF01107163	28	23	VF01107855	2	13	VF01111179	63	5	VF01112307	2	26
VF01107163	40	15	VF01107858	83	8	VF01111184	67	26	VF01112307	17	7
VF01107163	47	86	VF01107858	84	8	VF01111184	71	7	VF01112307	56	11
VF01107163	51	52	VF01107858	85	8	VF01111184	72	7	VF01112307	66	32
VF01107163	52	5	VF01108524	50	79	VF01111298	47	4	VF01112307	74	35

Feedex 360 T / Part No Index



Part No.	Page	Pos No	Part No.	Page	Pos No	Part No.	Page	Pos No	Part No.	Page	Pos No
VF01112307	91	7	VF01112418	57	8	VF01112447	80	21	VF01112824	77	11
VF01112322	37	9	VF01112418	66	21	VF01112447	81	21	VF01112824	90	16
VF01112322	51	51	VF01112418	74	13	VF01112451	74	33	VF01112850	11	29
VF01112322	66	31	VF01112429	2	18	VF01112451	94	14	VF01112858	8	8
VF01112322	77	6	VF01112429	14	12	VF01112451	95	23	VF01112858	13	2
VF01112322	79	19	VF01112429	29	1	VF01112476	94	15	VF01112886	1	16
VF01112322	80	19	VF01112429	30	1	VF01112476	95	24	VF01112886	6	12
VF01112322	81	19	VF01112429	47	6	VF01112529	1	33	VF01112886	8	20
VF01112322	91	5	VF01112429	48	2	VF01112529	13	8	VF01112886	11	11
VF01112333	47	45	VF01112429	48	30	VF01112529	14	16	VF01112886	19	101
VF01112333	48	29	VF01112429	69	20	VF01112529	15	10	VF01112886	20	101
VF01112333	49	41	VF01112429	74	17	VF01112529	78	30	VF01112886	21	101
VF01112333	51	31	VF01112429	75	20	VF01112538	1	38	VF01112886	22	101
VF01112333	55	7	VF01112429	78	15	VF01112538	13	7	VF01112886	82	11
VF01112333	57	7	VF01112429	79	9	VF01112538	14	14	VF01112916	78	13
VF01112333	60	7	VF01112429	80	9	VF01112538	32	2	VF01112972	61	1
VF01112333	69	43	VF01112429	81	9	VF01112538	79	10	VF01114357	16	19
VF01112333	75	43	VF01112429	91	10	VF01112538	80	10	VF01114357	24	26
VF01112333	90	13	VF01112429	95	21	VF01112538	81	10	VF01114357	25	26
VF01112341	42	19	VF01112439	16	3	VF01112683	54	4	VF01114357	26	10
VF01112341	47	81	VF01112439	28	4	VF01112683	57	9	VF01114357	27	10
VF01112341	48	4	VF01112439	29	27	VF01112687	55	9	VF01114357	29	3
VF01112341	50	25	VF01112439	30	27	VF01112687	56	12	VF01114357	30	3
VF01112341	53	6	VF01112439	31	20	VF01112687	83	23	VF01114357	33	56
VF01112350	60	13	VF01112439	32	20	VF01112687	84	23	VF01114357	34	23
VF01112356	98	6	VF01112439	91	81	VF01112687	85	23	VF01114357	35	17
VF01112407	82	7	VF01112439	92	1	VF01112709	82	9	VF01114357	36	41
VF01112407	91	13	VF01112439	93	1	VF01112803	64	23	VF01114357	42	10
VF01112418	28	17	VF01112439	94	13	VF01112824	17	8	VF01114357	47	66
VF01112418	34	7	VF01112439	95	22	VF01112824	40	18	VF01114357	48	17
VF01112418	47	46	VF01112447	29	33	VF01112824	56	14	VF01114357	52	19
VF01112418	48	11	VF01112447	30	33	VF01112824	60	14	VF01114357	64	19
VF01112418	55	8	VF01112447	54	11	VF01112824	74	41	VF01114357	64	28

Feedex 360 T / Part No Index



Part No.	Page	Pos No	Part No.	Page	Pos No	Part No.	Page	Pos No	Part No.	Page	Pos No
VF01114357	65	17	VF01116705	35	2	VF01120692	49	47	VF01122389	26	9
VF01114357	66	22	VF01116705	37	16	VF01120692	56	25	VF01122389	27	9
VF01114357	74	30	VF01116705	41	20	VF01120692	78	24	VF01122389	29	5
VF01114357	82	15	VF01116708	24	13	VF01120693	17	11	VF01122389	30	5
VF01114357	91	12	VF01116708	25	13	VF01120693	43	26	VF01122389	33	55
VF01114357	91	79	VF01116710	33	44	VF01120693	44	30	VF01122389	43	2
VF01114357	92	7	VF01116731	35	7	VF01120693	45	21	VF01122389	44	2
VF01114357	93	7	VF01116740	35	4	VF01120694	10	9	VF01122389	45	14
VF01115021	49	21	VF01116740	36	62	VF01120696	83	27	VF01123290	11	27
VF01115438	61	11	VF01116740	37	15	VF01120696	84	27	VF01123749	35	18
VF01115441	66	15	VF01116740	38	12	VF01120696	85	27	VF01123749	50	59
VF01115441	74	38	VF01116740	42	26	VF01120697	86	8	VF01123863	69	12
VF01115457	17	14	VF01116758	33	37	VF01120697	87	8	VF01123863	75	12
VF01115457	69	10	VF01116946	83	29	VF01120697	88	8	VF01123941	34	3
VF01115457	75	10	VF01116946	84	29	VF01120700	89	24	VF01123941	39	8
VF01115460	69	3	VF01116946	85	29	VF01120915	11	28	VF01124441	3	21
VF01115478	55	14	VF01118100	78	23	VF01120923	13	3	VF01124633	24	14
VF01115478	56	17	VF01118111	78	25	VF01121766	26	23	VF01124633	25	14
VF01115478	57	14	VF01118645	62	26	VF01121766	27	23	VF01124633	49	33
VF01115478	78	22	VF01118675	40	19	VF01121766	31	11	VF01124663	89	27
VF01116622	35	21	VF01118699	28	8	VF01121766	32	11	VF01124703	69	27
VF01116622	36	72	VF01118699	29	39	VF01121797	11	40	VF01124703	75	27
VF01116622	37	1	VF01118699	30	39	VF01121808	11	41	VF01125146	26	5
VF01116622	38	49	VF01118736	26	12	VF01121824	34	4	VF01125146	27	5
VF01116622	39	12	VF01118736	29	4	VF01121824	39	9	VF01125146	29	6
VF01116622	40	28	VF01118736	30	4	VF01122071	19	62	VF01125146	30	6
VF01116622	41	19	VF01118736	31	5	VF01122071	20	62	VF01125146	31	7
VF01116622	42	41	VF01118736	32	5	VF01122072	11	21	VF01125146	32	7
VF01116626	26	17	VF01119806	52	15	VF01122072	16	23	VF01125152	26	18
VF01116626	27	17	VF01120613	89	14	VF01122072	35	24	VF01125152	27	18
VF01116626	29	31	VF01120671	89	15	VF01122072	49	15	VF01125152	29	29
VF01116626	33	62	VF01120692	8	15	VF01122072	50	19	VF01125801	16	24
VF01116653	33	63	VF01120692	11	17	VF01122072	95	18	VF01126049	91	14

Feedex 360 T / Part No Index



Part No.	Page	Pos No	Part No.	Page	Pos No	Part No.	Page	Pos No	Part No.	Page	Pos No
VF01126186	96	4	VF01127856	55	13	VF01137321	84	19	VF01139339	17	18
VF01126332	41	27	VF01127856	56	15	VF01137321	85	19	VF01139339	86	12
VF01126332	95	31	VF01127856	57	13	VF01137379	1	29	VF01139339	88	12
VF01126929	3	16	VF01127856	83	25	VF01137379	2	20	VF01139468	11	23
VF01126974	26	15	VF01127856	84	25	VF01137526	55	15	VF01139468	41	28
VF01126974	27	15	VF01127856	85	25	VF01137526	56	20	VF01139468	49	10
VF01127346	35	22	VF01128192	63	42	VF01137526	57	15	VF01139650	96	6
VF01127346	36	74	VF01128266	42	27	VF01137624	12	20	VF01139722	46	21
VF01127346	37	14	VF01128272	1	35	VF01137628	50	48	VF01139735	89	21
VF01127346	38	48	VF01131116	37	5	VF01137628	68	6	VF01140002	7	10
VF01127346	39	11	VF01132262	52	13	VF01137628	70	6	VF01140002	9	6
VF01127346	40	29	VF01132294	65	14	VF01137628	73	6	VF01141006	37	8
VF01127346	41	18	VF01132621	49	30	VF01137628	76	6	VF01141006	91	16
VF01127346	42	42	VF01132625	11	33	VF01137633	28	7	VF01141006	98	12
VF01127538	47	5	VF01133784	92	8	VF01137633	29	37	VF01141047	17	10
VF01127538	48	3	VF01133784	93	8	VF01137633	30	37	VF01141112	74	24
VF01127538	68	15	VF01133798	6	7	VF01137633	33	40	VF01141112	91	15
VF01127538	69	19	VF01133922	33	38	VF01137837	16	7	VF01141159	83	20
VF01127538	70	11	VF01135950	64	6	VF01137990	89	8	VF01141159	84	20
VF01127538	73	15	VF01136666	56	10	VF01138374	67	34	VF01141159	85	20
VF01127538	74	19	VF01136686	14	3	VF01138374	71	6	VF01141235	42	4
VF01127538	75	19	VF01136686	15	3	VF01138374	72	6	VF01141295	39	3
VF01127538	76	11	VF01136686	16	16	VF01138374	95	32	VF01141296	39	2
VF01127538	79	13	VF01136687	16	9	VF01138412	95	30	VF01141364	69	24
VF01127538	80	13	VF01136762	70	3	VF01138686	67	36.1	VF01141364	75	24
VF01127538	81	13	VF01136762	76	3	VF01138951	74	40	VF01141365	69	26
VF01127538	94	20	VF01136763	67	22	VF01138951	90	14	VF01141365	75	26
VF01127538	96	5	VF01136930	39	16	VF01138989	47	65	VF01141391	38	37
VF01127856	10	19	VF01136930	61	7	VF01138989	48	15	VF01141455	50	76
VF01127856	11	8	VF01137130	89	26.2	VF01138989	82	6	VF01141838	38	36
VF01127856	17	21	VF01137252	90	9	VF01139169	14	6	VF01142006	33	35
VF01127856	18	3	VF01137321	2	11	VF01139169	15	6	VF01142023	31	24
VF01127856	54	5	VF01137321	83	19	VF01139169	16	15	VF01142023	32	24

Feedex 360 T / Part No Index



Part No.	Page	Pos No	Part No.	Page	Pos No	Part No.	Page	Pos No	Part No.	Page	Pos No
VF01142049	96	7	VF01142805	68	5	VF01157344	75	11	VF01177810	2	31
VF01142077	35	16	VF01142805	73	5	VF01157344	95	29	VF01177887	3	23
VF01142083	26	22	VF01142806	68	3	VF01157345	39	17	VF01177888	2	33
VF01142083	27	22	VF01142806	73	3	VF01157345	61	8	VF01178250	70	17
VF01142083	31	12	VF01142826	91	19	VF01157348	67	29	VF01178250	76	17
VF01142083	32	12	VF01142841	83	31	VF01157348	71	16	VF01211882	29	24
VF01142086	83	7	VF01142841	84	31	VF01157348	72	16	VF01211882	30	24
VF01142086	84	7	VF01142841	85	31	VF01157381	83	26	VF01211882	42	2
VF01142086	85	7	VF01142841	86	17	VF01157381	84	26	VF01292484	43	31
VF01142213	74	16	VF01142841	87	17	VF01157381	85	26	VF01292484	44	35
VF01142246	28	9	VF01142841	88	17	VF01157382	67	30	VF01292484	45	26
VF01142247	26	13	VF01142856	50	49	VF01157382	71	15	VF01397550	62	4
VF01142247	29	8	VF01142856	98	11	VF01157382	72	15	VF01397555	39	14
VF01142247	30	8	VF01142889	62	18	VF01163589	43	25	VF01397575	3	14
VF01142492	1	17	VF01142958	77	2	VF01163589	44	29	VF01397576	3	10
VF01142556	2	32	VF01142993.01	1	18	VF01163589	45	20	VF01397597	61	14
VF01142556	10	17	VF01143009	95	19	VF01164017	62	12	VF01397598	42	25
VF01142556	11	6	VF01143017	62	14	VF01167577	75	28	VF01397598	63	50
VF01142556	55	18	VF01143083	42	18	VF01167953	38	30	VF01397605	12	12
VF01142556	57	18	VF01143090	86	16	VF01167956	38	31	VF01397605	12	12.1
VF01142565	42	30	VF01143090	88	16	VF01169436	52	21	VF01397609	68	9
VF01142565	47	59	VF01143097	62	5	VF01169581	40	3	VF01397609	70	9
VF01142565	48	26	VF01143103	40	17	VF01169697	82	10	VF01397609	73	9
VF01142565	49	35	VF01143104	35	13	VF01172407	2	19	VF01397609	76	9
VF01142565	79	2	VF01143104	40	20	VF01173381	67	25	VF01397661	10	12
VF01142565	80	2	VF01151892	62	16	VF01173381	74	34	VF01397704	63	33
VF01142565	81	2	VF01151892	63	16	VF01173639	38	32	VF01397760	43	24
VF01142565	82	21	VF01157337	50	20	VF01173914	69	15	VF01397760	44	28
VF01142565	91	21	VF01157337	78	21	VF01173914	74	18	VF01397760	45	19
VF01142641	39	7	VF01157338	69	13	VF01173914	75	15	VF01397770	33	2
VF01142796	83	24	VF01157338	75	13	VF01175657	89	16	VF01397855	65	8
VF01142796	84	24	VF01157344	37	19	VF01177316	42	5	VF01397859	3	18
VF01142796	85	24	VF01157344	69	11	VF01177466	94	25	VF01397863	67	28

Feedex 360 T / Part No Index



Part No.	Page	Pos No	Part No.	Page	Pos No	Part No.	Page	Pos No	Part No.	Page	Pos No
VF01397863	71	8	VF06207534	46	3	VF06209768	15	13	VF06209769	14	15
VF01397863	72	8	VF06207534	47	18	VF06209768	16	10	VF06209769	15	16
VF01397870	64	3	VF06207534	48	14	VF06209768	28	5	VF06209769	16	29
VF01397871	64	4	VF06207534	50	14	VF06209768	29	9	VF06209769	24	22
VF01397896	62	19	VF06207535	46	6	VF06209768	30	9	VF06209769	25	22
VF01397896	63	8	VF06207535	47	21	VF06209768	31	16	VF06209769	49	6
VF01397920	62	20	VF06207535	52	3	VF06209768	32	16	VF06209769	53	5
VF01397920	63	20	VF06207535	68	11	VF06209768	34	8	VF06209769	78	19
VF01397931	68	14	VF06207557	82	14	VF06209768	47	16	VF06209769	79	12
VF01397931	70	10	VF06208913	67	24	VF06209768	48	13	VF06209769	80	12
VF01397931	73	14	VF06208913	71	21	VF06209768	49	38	VF06209769	81	12
VF01397931	76	10	VF06208913	72	21	VF06209768	54	13	VF06209769	90	17
VF01397933	43	27	VF06208934	89	6	VF06209768	55	12	VF06209769	94	18
VF01397933	44	31	VF06208962	90	11	VF06209768	57	12	VF06209774	10	8
VF01397933	45	22	VF06209168	10	7	VF06209768	66	24	VF06209774	17	17
VF01403239	62	21	VF06209245	82	18	VF06209768	69	21	VF06209774	56	16
VF01404321	63	46	VF06209249	46	7	VF06209768	69	39	VF06209778	11	3
VF02953340	67	23	VF06209411	78	14	VF06209768	74	14	VF06209778	31	4
VF02953368	28	11	VF06209459	79	8	VF06209768	75	21	VF06209778	32	4
VF02953368	29	38	VF06209459	80	8	VF06209768	75	39	VF06209778	41	14
VF02953368	30	38	VF06209459	81	8	VF06209768	78	18	VF06209778	46	8
VF02953369	26	16	VF06209459	82	8	VF06209768	78	20	VF06209919	58	36
VF02953369	27	16	VF06209465	50	45	VF06209768	79	11	VF06209952	11	18
VF02953369	29	30	VF06209473	56	13	VF06209768	80	11	VF06210000	58	15
VF02953408	63	34	VF06209476	66	19	VF06209768	81	11	VF06210009	11	31
VF02953409	63	32	VF06209476	74	22	VF06209768	82	12	VF06210014	13	4
VF02953410	63	41	VF06209484	78	16	VF06209768	91	18	VF06210014	37	2
VF03.110.02.140	16	21	VF06209580	38	28	VF06209768	92	2	VF06210015	25	28
VF03.110.02.140	19	60	VF06209764	52	14	VF06209768	93	2	VF06210015	60	27
VF03.110.02.140	20	60	VF06209765	64	8	VF06209768	94	19	VF06210017	24	10
VF04308511	64	9	VF06209765	65	15	VF06209768	95	28	VF06210017	25	10
VF06205968	50	50	VF06209765	91	37	VF06209769	1	34	VF06210032	49	2
VF06207186	16	20	VF06209768	14	13	VF06209769	13	9	VF06210033	69	8

Feedex 360 T / Part No Index



Part No.	Page	Pos No	Part No.	Page	Pos No	Part No.	Page	Pos No	Part No.	Page	Pos No
VF06210033	75	8	VF06214189	91	38	VF06214207	24	12	VF06214313	71	32
VF06211876	56	23	VF06214192	46	5	VF06214207	25	12	VF06214313	72	32
VF06212426	67	31	VF06214192	47	20	VF06214207	46	9	VF06214313	76	14
VF06212426	71	22	VF06214192	48	5	VF06214207	49	7	VF06214314	67	43
VF06212426	72	22	VF06214192	49	37	VF06214207	60	28	VF06214314	71	31
VF06212435	67	32	VF06214192	50	15	VF06214207	90	18	VF06214314	72	31
VF06213664	61	15	VF06214192	51	30	VF06214207	94	26	VF06214332	78	26
VF06213700	77	9	VF06214192	98	7	VF06214215	49	4	VF06214333	78	26.1
VF06213737	62	15	VF06214193	53	7	VF06214215	52	7	VF06214358	98	13
VF06213973	64	15	VF06214193	77	7	VF06214217	3	24	VF06214420	67	35
VF06213974	65	10	VF06214193	82	22	VF06214217	41	16	VF06214420	71	25
VF06213977	64	2	VF06214197	16	12	VF06214220	10	18	VF06214420	72	25
VF06213982	65	18	VF06214197	31	15	VF06214220	11	7	VF06214481	67	36
VF06214036	91	35	VF06214197	32	15	VF06214226	11	20	VF06214481	71	20
VF06214037	91	26	VF06214197	47	15	VF06214226	16	22	VF06214481	72	20
VF06214041	64	20	VF06214197	48	12	VF06214226	41	26	VF06214486	55	16
VF06214045	63	6	VF06214197	54	12	VF06214226	56	24	VF06214486	56	21
VF06214156	33	53	VF06214197	92	3	VF06214226	69	5	VF06214486	57	16
VF06214189	24	27	VF06214197	93	3	VF06214226	95	35	VF06214490	2	20
VF06214189	25	27	VF06214198	82	24	VF06214228	50	18	VF06214491	2	20
VF06214189	26	11	VF06214202	34	5	VF06214229	11	19	VF06214492	2	20
VF06214189	27	11	VF06214206	15	15	VF06214229	50	17	VF06214493	1	31
VF06214189	29	10	VF06214206	16	28	VF06214234	69	4	VF06214499	89	26.1
VF06214189	30	10	VF06214206	24	23	VF06214237	39	4	VF06214500	89	26
VF06214189	47	67	VF06214206	25	23	VF06214238	39	5	VF06214504	89	22
VF06214189	48	16	VF06214206	31	3	VF06214238	61	9	VF06214519	2	21
VF06214189	52	10	VF06214206	32	3	VF06214246	2	28	VF06214520	2	21
VF06214189	52	20	VF06214206	79	14	VF06214288	58	34	VF06214521	2	21
VF06214189	64	27	VF06214206	80	14	VF06214306	33	39	VF06214570	67	46
VF06214189	66	26	VF06214206	81	14	VF06214307	26	25	VF06214572	67	46.1
VF06214189	74	29	VF06214206	94	21	VF06214307	27	25	VF06214585	36	6
VF06214189	82	16	VF06214206	95	34	VF06214313	67	44	VF06214588	1	5
VF06214189	91	3	VF06214207	1	36	VF06214313	70	14	VF06214633	50	11

Feedex 360 T / Part No Index



Part No.	Page	Pos No	Part No.	Page	Pos No	Part No.	Page	Pos No	Part No.	Page	Pos No
VF06214938	67	37	VF06216397	36	69	VF06216757	27	21	VF06246795	67	4
VF06214948	89	12	VF06216397	38	39	VF06216757	28	2	VF06246795	71	10.1
VF06214950	89	3	VF06216397	39	13	VF06216757	29	12	VF06246795	72	10.1
VF06214992	91	28	VF06216397	41	7	VF06216757	30	12	VF06258500	35	19
VF06215016	89	20	VF06216397	63	48	VF06216757	31	18	VF06264206	50	56
VF06215027	67	38	VF06216479	37	28	VF06216757	32	18	VF06264206	54	9
VF06215027	71	13	VF06216479	42	38	VF06216762	29	35	VF06264206	94	11
VF06215027	72	13	VF06216479	52	22	VF06216762	31	8	VF06272542	3	15
VF06215029	90	21	VF06216479	62	22	VF06216762	32	8	VF06273686	78	17
VF06215308	69	37	VF06216479	63	22	VF06216763	26	24	VF06273756	86	2
VF06215308	75	37	VF06216479	64	13	VF06216763	27	24	VF06273756	87	2
VF06215315	49	18	VF06216479	65	12	VF06216763	29	32	VF06273756	88	2
VF06215425	36	3	VF06216480	37	26	VF06216763	30	32	VF06273759	6	10
VF06215513	52	8	VF06216480	65	13	VF06216763	31	17	VF06273759	8	21
VF06215561	66	29	VF06216527	43	21	VF06216771	26	1	VF06273759	10	16
VF06215561	74	39	VF06216527	44	26	VF06216771	27	1	VF06273759	11	10
VF06215561	90	22	VF06216527	45	17	VF06216772	26	2	VF06273759	19	100
VF06215561	94	22	VF06216527	83	10	VF06216772	27	2	VF06273759	20	100
VF06215561	95	36	VF06216527	84	10	VF06216772	31	10	VF06273759	21	100
VF06215565	50	62	VF06216527	85	10	VF06216772	32	10	VF06273759	22	100
VF06215666	50	63	VF06216527	86	10	VF06216773	42	6	VF06273759	83	30
VF06215666	68	18	VF06216527	87	10	VF06216815	42	1	VF06273759	84	30
VF06215666	69	22	VF06216527	88	10	VF06216815	43	23	VF06273759	85	30
VF06215666	70	13	VF06216745	31	22	VF06216815	44	27	VF06273759	86	9
VF06215666	73	18	VF06216745	32	22	VF06216815	45	18	VF06273759	87	9
VF06215666	75	22	VF06216747	31	19	VF06216836	33	51	VF06273759	88	9
VF06215666	76	13	VF06216747	32	19	VF06216854	43	17	VF06273763	83	21
VF06215671	17	22	VF06216756	28	1	VF06216854	44	20	VF06273763	84	21
VF06216097	97	4	VF06216756	29	34	VF06216854	45	16	VF06273763	85	21
VF06216396	35	20	VF06216756	30	34	VF06216908	24	15	VF06273771	83	22
VF06216396	65	7	VF06216756	31	25	VF06216908	25	15	VF06273771	84	22
VF06216397	34	21	VF06216756	32	25	VF06217046	38	46	VF06273771	85	22
VF06216397	35	15	VF06216757	26	21	VF06243750	95	1	VF06273854	74	15

Feedex 360 T / Part No Index



Part No.	Page	Pos No	Part No.	Page	Pos No	Part No.	Page	Pos No	Part No.	Page	Pos No
VF06273871	89	10	VF06296264	66	2	VF06557587	2	10	VF06567492	75	30
VF06273872	89	5	VF06296264	74	6	VF06558198	69	35	VF06567493	69	29
VF06273873	86	3	VF06296285	67	5	VF06558198	75	35	VF06570007	89	13
VF06273873	87	3	VF06296285	71	4	VF06558560	56	5	VF06570185	95	15
VF06273873	88	3	VF06296285	72	4	VF06558561	56	6	VF06570195	95	14
VF06277296	26	4	VF06301830	67	3	VF06558562	56	7	VF06570724	96	1
VF06277296	27	4	VF06550287	78	28	VF06558565	57	4	VF06570740	96	2
VF06277296	29	13	VF06550405	1	37	VF06558567	55	5	VF06570914	89	7
VF06277296	30	13	VF06551690	42	3	VF06558567	57	5	VF06570920	66	9
VF06277296	31	6	VF06551694	42	22	VF06558569	56	8	VF06570925	77	1
VF06277296	32	6	VF06552196	78	29	VF06558571	54	8	VF06571004	67	7
VF06277504	46	17	VF06552906	79	18	VF06558644	78	10	VF06571005	66	7
VF06277504	69	41	VF06552906	80	18	VF06558728	16	13	VF06571018	41	5
VF06277504	75	41	VF06552906	81	18	VF06558733	16	11	VF06571032	89	1
VF06277504	90	4	VF06553944	86	13	VF06558801	26	14	VF06571033	89	25
VF06277509	86	6	VF06553944	87	13	VF06558801	27	14	VF06571090	66	12
VF06277509	87	6	VF06553944	88	13	VF06558917	14	2	VF06571094	66	10
VF06277509	88	6	VF06554188	2	6	VF06558917	15	2	VF06571099	66	11
VF06277514	90	23	VF06554451	42	37	VF06558937	82	1	VF06571134	66	3
VF06277516	67	41	VF06554525	56	3	VF06558991	26	3	VF06571148	67	42
VF06277516	71	26.2	VF06554678	25	1.2	VF06558992	31	9	VF06571150	83	11
VF06277516	72	26.2	VF06554790	55	1	VF06558992	32	9	VF06571150	84	11
VF06277517	86	15	VF06554790	56	19	VF06559244	67	14	VF06571150	85	11
VF06277517	87	15	VF06554790	57	1	VF06562016	94	28	VF06571172	94	8
VF06277517	88	15	VF06555222	37	22	VF06564448	50	57	VF06571186	95	11
VF06277518	86	14	VF06556268	55	3.1	VF06564448	54	10	VF06571196	82	3
VF06277518	88	14	VF06556619	60	37	VF06564448	61	13	VF06571198	82	2
VF06278720	94	23	VF06556728	90	8	VF06564448	94	1	VF06571205	89	2
VF06278720	95	5	VF06556744	69	23	VF06564733	69	1	VF06571309	67	10
VF06278838	64	12	VF06556744	75	23	VF06564733	75	1	VF06571309	71	9.1
VF06282196	67	2	VF06556821	91	23	VF06564735	69	25	VF06571309	72	9.1
VF06286217	41	1.1	VF06556888	1	39	VF06564735	75	25	VF06571314	67	40
VF06295430	2	8	VF06557524	9	13	VF06567492	69	28	VF06571314	71	27

Feedex 360 T / Part No Index



Part No.	Page	Pos No	Part No.	Page	Pos No	Part No.	Page	Pos No	Part No.	Page	Pos No
VF06571314	72	27	VF06577097	46	11	VF06577397	67	6	VF06577584	41	9
VF06571321	67	11	VF06577109	94	2	VF06577405	66	5	VF06577586	95	9
VF06571322	66	4	VF06577109	95	2	VF06577406	67	8	VF06577864	36	63
VF06571322	74	31	VF06577110	94	3	VF06577407	67	9	VF06577918	92	5
VF06571323	66	6	VF06577110	95	3	VF06577420	69	18	VF06577919	92	6
VF06571323	74	32	VF06577111	94	4	VF06577420	75	18	VF06577968	78	27
VF06571325	82	19	VF06577111	95	4	VF06577421	69	17	VF06577987	37	6
VF06571330	33	61	VF06577152	50	13	VF06577421	75	17	VF06578035	16	17
VF06571331	41	11	VF06577154	50	12	VF06577422	69	14	VF06578035	24	24
VF06571341	33	36	VF06577181	50	77	VF06577422	75	14	VF06578035	25	24
VF06571341	34	2	VF06577182	50	78	VF06577423	68	10	VF06578035	26	8
VF06571355	66	30	VF06577183	50	46	VF06577426	66	8	VF06578035	27	8
VF06572448	47	79	VF06577184	51	32	VF06577432	67	17.1	VF06578035	29	20
VF06572550	54	7	VF06577192	50	75	VF06577432	71	26.1	VF06578035	30	20
VF06575213	42	24	VF06577238	46	1	VF06577432	72	26.1	VF06578035	33	57
VF06575216	42	43	VF06577240	46	2	VF06577442	94	5	VF06578349	78	2
VF06575217	42	44	VF06577242	46	12	VF06577442	95	6	VF06578608	37	17
VF06575227	2	34	VF06577305	89	9	VF06577469	41	12	VF06578609	37	18
VF06575227	55	6	VF06577317	83	5	VF06577483	95	7	VF06578611	37	4
VF06575227	57	6	VF06577317	84	5	VF06577489	95	10	VF06578645	38	27
VF06575228	54	3	VF06577317	85	5	VF06577494	95	12	VF06578646	51	33
VF06575231	1	1	VF06577328	86	11	VF06577496	94	10	VF06578650	37	23
VF06575248	2	30	VF06577335	83	14	VF06577496	95	13	VF06578651	37	24
VF06575249	2	30	VF06577335	84	14	VF06577498	95	16	VF06578750	78	4
VF06575250	2	30	VF06577335	85	14	VF06577514	91	33	VF06578761	78	7
VF06576503	36	4	VF06577348	90	1	VF06577521	91	34	VF06578826	78	8
VF06576507	37	25	VF06577349	90	2	VF06577562	46	19	VF06578830	41	10
VF06576830	69	16	VF06577374	86	1	VF06577563	46	20	VF06578868	83	16
VF06576830	75	16	VF06577385	90	7	VF06577567	35	10	VF06578868	84	16
VF06577030	78	11	VF06577387	69	40	VF06577579	79	7	VF06578868	85	16
VF06577064	78	3	VF06577387	75	40	VF06577579	80	7	VF06578892	94	24
VF06577068	64	11	VF06577389	82	4	VF06577579	81	7	VF06578934	68	4
VF06577095	46	13	VF06577391	82	5	VF06577583	94	7	VF06578934	73	4

Feedex 360 T / Part No Index



Part No.	Page	Pos No	Part No.	Page	Pos No	Part No.	Page	Pos No	Part No.	Page	Pos No
VF06578978	2	24	VF06587235	56	9	VF16511633	52	9	VF16513618	4	56
VF06578992	50	73	VF06587374	51	28	VF16511646	11	37	VF16513618	5	56
VF06578993	50	74	VF06587375	51	27	VF16512287	65	1	VF16513621	3	5
VF06579237	47	64	VF06587559	86	4	VF16512621	12	11	VF16513622	3	6
VF06579237	48	28	VF06587559	87	4	VF16512621	12	11.1	VF16513624	3	8
VF06579350	91	25	VF06587559	88	4	VF16512812	37	6	VF16513677	31	21
VF06579358	89	23	VF06587560	69	42	VF16513000	1	27	VF16513677	32	21
VF06579491	41	23	VF06587560	75	42	VF16513003	1	30	VF16513686	15	7
VF06579959	62	2	VF06587560	90	5	VF16513217	1	3	VF16513859	14	5
VF06579960	62	3	VF06587590	41	1	VF16513246	56	1	VF16513859	15	5
VF06579961	62	17	VF06587598	78	6	VF16513250	66	1	VF16513860	14	9
VF06579979	62	10	VF06587602	78	5	VF16513250	67	1	VF16513861	14	11
VF06579981	63	42.1	VF06587631	16	6	VF16513257	10	5	VF16513869	24	20
VF06579982	63	42.2	VF06587659	24	3	VF16513259	10	14	VF16513869	25	20
VF06580174	1	7	VF06587672	51	40	VF16513298	67	12	VF16513900	24	7
VF06580546	75	29	VF06587674	51	39	VF16513298	71	9	VF16513900	25	7
VF06581181	36	71	VF0905191000	66	25	VF16513298	72	9	VF16513933	62	27.1
VF06581181	41	4	VF0905191000	74	15.1	VF16513299	67	13	VF16513942	62	23
VF06581494	46	10	VF11439109110	2	9	VF16513299	71	10	VF16513948	33	34
VF06581954	4	54	VF16503935	21	82	VF16513299	72	10	VF16513977	84	15
VF06581954	5	54	VF16503935	22	68A	VF16513473	68	8	VF16514101	17	12
VF06582340	4	26	VF16503949	8	6	VF16513473	70	8	VF16514201	69	9
VF06582340	5	26	VF16503949	21	72	VF16513473	73	8	VF16514201	75	9
VF06582524	34	1	VF16503949	22	72	VF16513473	76	8	VF16514460	65	2
VF06582530	34	1	VF16504079	36	5	VF16513522	31	1	VF16514462	52	12
VF06584800	38	26	VF16511004	39	1.1	VF16513522	32	1	VF16514629	36	5
VF06585321	2	2	VF16511031	77	10	VF16513601	4	15	VF16515017	7	4
VF06586171	4	12	VF16511336	94	6	VF16513601	5	15	VF16515017	9	12
VF06586171	5	12	VF16511337	95	8	VF16513605	4	30	VF16515089	87	1
VF06586755	4	24	VF16511469	62	27	VF16513605	5	30	VF16515089	88	1
VF06586755	5	24	VF16511469	63	15	VF16513607	3	2.1	VF16515159	39	15
VF06587052	62	13	VF16511577	46	14	VF16513616	4	53	VF16515159	61	6
VF06587227	60	38	VF16511632	52	2	VF16513616	5	53	VF16515167	83	6

Feedex 360 T / Part No Index



Part No.	Page	Pos No	Part No.	Page	Pos No	Part No.	Page	Pos No	Part No.	Page	Pos No
VF16515167	84	6	VF16515927	46	23	VF16516536	87	5	VF16516717	43	28
VF16515167	85	6	VF16515928	47	3	VF16516558	40	13	VF16516717	44	32
VF16515168	83	9	VF16515928	48	55	VF16516640	1	2	VF16516717	45	23
VF16515168	84	9	VF16515938	49	1	VF16516646	8	1	VF16516750	86	5
VF16515168	85	9	VF16515959	49	40	VF16516651	93	6	VF16516754	83	28
VF16515251	55	3	VF16515976	35	25	VF16516652	93	5	VF16516754	84	28
VF16515428	33	33	VF16515977	64	17	VF16516653	84	13	VF16516754	85	28
VF16515446	63	38	VF16515987	35	26	VF16516653	85	13	VF16516766	83	13
VF16515448	63	39	VF16515988	49	42	VF16516654	84	13.1	VF16516767	83	13.1
VF16515453	62	11	VF16516319	47	11	VF16516654	85	13.1	VF16516768	83	13.2
VF16515468	62	24	VF16516320	47	13	VF16516655	84	13.2	VF16516769	83	13.3
VF16515591	42	31	VF16516330	64	1	VF16516655	85	13.2	VF16516772	86	7
VF16515593	42	33	VF16516333	64	18	VF16516656	84	13.3	VF16516772	87	7
VF16515605	53	1	VF16516335	65	6	VF16516656	85	13.3	VF16516772	88	7
VF16515613	53	3	VF16516337	65	9	VF16516657	84	13.4	VF16517079	93	4
VF16515614	53	2	VF16516363	11	13	VF16516657	85	13.4	VF16517144	61	3
VF16515716	54	1	VF16516368	11	16	VF16516658	84	13.5	VF16517146	39	1
VF16515739	65	11	VF16516374	11	22	VF16516663	84	4	VF16517151	57	2
VF16515748	77	4	VF16516380	11	14	VF16516663	85	4	VF16517160	61	2
VF16515749	77	5	VF16516382	14	7	VF16516664	83	18	VF16517165	61	4
VF16515750	77	3	VF16516398	11	36	VF16516664	84	18	VF16517171	54	2
VF16515751	78	9	VF16516399	47	17	VF16516664	85	18	VF16517193	40	22
VF16515902	46	15	VF16516404	47	1	VF16516677	43	1	VF16517193	41	24
VF16515904	46	16	VF16516426	24	4	VF16516679	83	15	VF16517194	36	61
VF16515915	47	49	VF16516426	25	4	VF16516696	43	5	VF16517194	40	23
VF16515915	48	49	VF16516440	15	9	VF16516699	43	6	VF16517197	39	10
VF16515917	47	50	VF16516441	15	11	VF16516700	43	7	VF16517197	40	24
VF16515917	48	50	VF16516442	15	17	VF16516701	43	8	VF16517215	52	16
VF16515918	47	41	VF16516442	16	26	VF16516702	43	9	VF16517215	65	3
VF16515918	48	41	VF16516500	11	25	VF16516705	43	10	VF16517499	69	7
VF16515920	47	42	VF16516507	14	1	VF16516706	43	12	VF16517499	75	7
VF16515920	48	42	VF16516507	15	1	VF16516707	43	13	VF16517792	63	31
VF16515926	46	22	VF16516512	11	34	VF16516708	43	14	VF16517917	63	40

Feedex 360 T / Part No Index



Part No.	Page	Pos No	Part No.	Page	Pos No	Part No.	Page	Pos No	Part No.	Page	Pos No
VF16517922	63	36	VF16602179	6	8	VF16610922	24	5	VF16611326	49	32
VF16517923	63	37	VF16602597	21	29	VF16610922	25	5	VF16611330	49	34
VF16518038	25	3	VF16602597	22	29	VF16610926	43	18	VF16611331	49	43
VF16518084	29	22	VF16602597	23	29	VF16610994	24	8	VF16611335	49	26
VF16518084	30	22	VF16602598	21	33	VF16610994	25	8	VF16611338	49	29
VF16518135	43	29	VF16602598	22	33	VF16611054	49	25	VF16611341	49	28
VF16518135	44	33	VF16602598	23	33	VF16611055	49	11	VF16611351	49	19
VF16518135	45	24	VF16602599	19	36	VF16611079	63	43.3	VF16611352	49	20
VF16518150	10	11	VF16602599	20	36	VF16611081	63	45	VF16611356	55	17
VF16518193	16	14	VF16602600	19	37	VF16611240	42	35	VF16611359	42	32
VF16518205	52	1	VF16602600	20	37	VF16611241	42	39	VF16611366	54	6
VF16518210	52	17	VF16602606	21	27A	VF16611242	42	36	VF16611382	35	30
VF16518245	4	1	VF16602606	22	27A	VF16611247	79	1	VF16611391	47	71
VF16518524	62	17.2	VF16602614	21	95	VF16611248	42	45	VF16611391	48	71
VF16518869	10	4	VF16602614	22	95	VF16611252	4	11	VF16611392	47	72
VF16518871	10	10	VF16602614	23	95	VF16611252	5	11	VF16611392	48	72
VF16518890	34	6	VF16602619	21	27	VF16611261	2	5	VF16611394	47	73
VF16518913	91	8	VF16602619	22	27	VF16611262	2	4	VF16611394	48	73
VF16518921	1	14	VF16604641	34	1.2	VF16611266	3	3	VF16611395	47	74
VF16518926	29	25	VF16604726	34	1.3	VF16611267	3	4	VF16611395	48	74
VF16518926	30	25	VF16604727	34	1.4	VF16611268	3	19	VF16611397	91	75
VF16518934	29	16	VF16604728	34	1.5	VF16611275	63	31.1	VF16611398	91	76
VF16518934	30	16	VF16604729	34	1.6	VF16611297	3	2	VF16611400	78	31
VF16518970	63	42	VF16604730	34	1.7	VF16611298	3	22	VF16611401	78	32
VF16519102	29	14	VF16606401	94	27.1	VF16611299	3	7	VF16611418	49	24
VF16519102	30	14	VF16606570	63	4	VF16611308	24	17	VF16611420	38	29
VF16519106	29	18	VF16610586	92	4	VF16611308	25	17	VF16611423	38	35
VF16519106	30	18	VF16610781	37	20	VF16611312	35	14	VF16611431	91	80
VF16519107	29	17	VF16610801	1	1.1	VF16611317	65	20	VF16611433	56	22
VF16519107	30	17	VF16610801	2	1	VF16611318	65	19	VF16611457	91	20
VF16519184	36	2	VF16610873	33	58	VF16611321	35	27	VF16611458	91	29
VF16601350	97	1	VF16610895	1	13	VF16611322	49	8	VF16611479	68	2
VF16601375	97	8	VF16610913	40	16	VF16611325	49	31	VF16611479	73	2

Feedex 360 T / Part No Index



Part No.	Page	Pos No	Part No.	Page	Pos No	Part No.	Page	Pos No	Part No.	Page	Pos No
VF16611480	63	7	VF16612431	8	18	VF16613356	79	16	VF16613435	33	3
VF16611487	68	1	VF16612438	21	22	VF16613356	80	16	VF16613436	33	48
VF16611490	50	10	VF16613236	62	7	VF16613356	81	16	VF16613439	33	42
VF16611492	11	1	VF16613237	62	8	VF16613359	91	22	VF16613441	33	43
VF16611497	13	1	VF16613238	62	9	VF16613360	57	3	VF16613443	33	45
VF16612402	7	15	VF16613240	33	52	VF16613364	34	24	VF16613445	33	46
VF16612405	19	98	VF16613243	63	44	VF16613374	77	12	VF16613446	33	49
VF16612405	20	98	VF16613246	37	7	VF16613377	46	24	VF16613447	33	50
VF16612405	21	98	VF16613246	40	25	VF16613380	33	54	VF16613449	34	10
VF16612405	22	98	VF16613248	13	6	VF16613387	62	6	VF16613449	40	10
VF16612405	23	98	VF16613255	24	1	VF16613389	97	10	VF16613456	79	6
VF16612406	21	31	VF16613255	25	1	VF16613390	97	6	VF16613456	80	6
VF16612406	22	31	VF16613256	25	1.1	VF16613391	97	3	VF16613456	81	6
VF16612406	23	31	VF16613261	3	1	VF16613392	97	2	VF16613458	79	17
VF16612407	7	5	VF16613267	17	1	VF16613394	62	1	VF16613458	80	17
VF16612407	9	14	VF16613273	56	2.1	VF16613396	63	1	VF16613458	81	17
VF16612408	7	9	VF16613283	63	49	VF16613400	67	15	VF16613460	79	5
VF16612408	9	4	VF16613283	65	21	VF16613405	50	1	VF16613460	80	5
VF16612412	21	73	VF16613296	78	1	VF16613406	50	2	VF16613460	81	5
VF16612412	22	74	VF16613306	36	68	VF16613408	50	3	VF16613464	50	47
VF16612413	8	2	VF16613311	35	9	VF16613409	50	4	VF16613469	51	47
VF16612423	8	12	VF16613313	35	1	VF16613410	50	5	VF16613470	51	48
VF16612424	8	9	VF16613313	40	21	VF16613411	50	6	VF16613493	51	34
VF16612425	8	10	VF16613315	35	3	VF16613412	50	7	VF16613495	38	34
VF16612426	8	11	VF16613317	35	6	VF16613413	50	8	VF16613497	38	45
VF16612427	8	7	VF16613319	35	5	VF16613417	50	52	VF16613499	50	9
VF16612428	8	13	VF16613321	35	8	VF16613418	50	51	VF16613719	97	9
VF16612429	8	14	VF16613325	36	73	VF16613421	50	54	VF16613728	97	7
VF16612429	21	17	VF16613337	24	2	VF16613422	50	53	VF16614169	1	26
VF16612429	22	17	VF16613337	25	2	VF16613427	50	55	VF16614444	9	2
VF16612430	8	17	VF16613354	79	4	VF16613432	50	58	VF16614447	7	13
VF16612430	21	24	VF16613354	80	4	VF16613433	33	41	VF16614447	9	9
VF16612430	22	24	VF16613354	81	4	VF16613434	33	47	VF16614454	83	17

Feedex 360 T / Part No Index



Part No.	Page	Pos No	Part No.	Page	Pos No	Part No.	Page	Pos No	Part No.	Page	Pos No
VF16614456	60	31	VF16614907	47	88	VF16617334	6	3	VF16630104	11	4.1
VF16614457	58	1	VF16614907	48	88	VF16617335	6	5	VF16630106	69	44
VF16614457	59	410	VF16614908	47	87	VF16618602	21	93	VF16630109	69	2
VF16614458	58	2	VF16614908	48	87	VF16618602	22	93	VF16630112	66	9.1
VF16614458	59	415	VF16614920	50	43	VF16618602	23	93	VF16630114	66	5.1
VF16614459	58	3	VF16614921	50	42	VF16618603	21	94	VF16630115	66	7.1
VF16614459	59	421	VF16614984	28	14	VF16618603	22	94	VF16630119	66	8.1
VF16614460	58	5	VF16614995	28	21	VF16618603	23	94	VF16630125	66	1.1
VF16614460	59	423	VF16615010	28	12	VF16618627	19	54	VF16630125	67	1.1
VF16614461	58	9	VF16615011	29	36	VF16618627	20	54	VF16630126	91	80
VF16614461	59	431	VF16615011	30	36	VF16618679	21	54	VF16630134	49	8.1
VF16614462	58	4	VF16615012	28	15	VF16618679	22	54	VF16630139	67	33
VF16614463	58	18	VF16615013	28	19	VF16618715	72	12	VF16630142	84	17
VF16614464	58	19	VF16615014	28	20	VF16622598	69	30	VF16630143	84	17.1
VF16614464	59	413	VF16615171	34	11	VF16624942	59	465	VF16630145	87	19
VF16614465	58	20	VF16615203	67	16	VF16625105	4	55	VF16630145	88	20
VF16614465	59	430	VF16615203	71	11	VF16625105	5	55	VF16630146	87	14
VF16614466	60	21	VF16615203	72	11	VF16625114	4	5	VF16630147	80	1
VF16614467	60	22	VF16615205	71	12	VF16625120	4	4	VF16630147	81	1
VF16614468	60	25	VF16616040	7	14	VF16630069	12	21	VF16630148	80	20
VF16614469	58	26	VF16616040	9	3	VF16630070	12	19	VF16630148	81	20
VF16614470	58	33	VF16616084	6	6	VF16630072	12	18	VF16630151	89	23.1
VF16614471	58	32	VF16617329	7	2	VF16630075	9	1	VF16630156	67	17
VF16614472	17	19	VF16617329	9	5	VF16630075	23	1	VF16630156	71	26
VF16614473	17	2	VF16617329.86	19	84	VF16630078	8	30	VF16630156	72	26
VF16614474	17	3	VF16617329.86	20	84	VF16630078	11	42	VF16630157	1	19
VF16614475	17	4	VF16617329.86	23	84	VF16630078	22	1	VF16630158	39	1.2
VF16614478	17	16	VF16617330	7	3	VF16630080	6	1	VF16630159	39	1.3
VF16614479	17	15	VF16617330.86	19	86	VF16630080	7	1	VF16630171	44	1
VF16614480	17	6	VF16617330.86	20	86	VF16630080	11	43.1	VF16630171	45	13
VF16614668	66	33	VF16617331	7	6	VF16630080	20	1	VF16630172	44	4
VF16614668	74	20	VF16617332	7	8	VF16630100	10	2	VF16630174	44	5
VF16614901	38	33	VF16617333	6	4	VF16630104	10	1	VF16630176	44	6

Feedex 360 T / Part No Index



Part No.	Page	Pos No	Part No.	Page	Pos No	Part No.	Page	Pos No	Part No.	Page	Pos No
VF16630178	44	7	VF16630506	27	6	VF16630736	74	9	VF16631126	70	15
VF16630180	44	8	VF16630507	26	7	VF16630736.01	74	9.1	VF16631126	76	15
VF16630182	44	9	VF16630507	27	7	VF16630737	73	1	VF16631129	76	5
VF16630184	44	10	VF16630548	17	20	VF16630738	74	5	VF16631133	70	16
VF16630186	44	11	VF16630548	87	16	VF16630740	71	1	VF16631133	76	16
VF16630188	44	12	VF16630549	87	12	VF16630742	74	25	VF16631134	76	2
VF16630190	44	13	VF16630646	26	19	VF16630743	71	23	VF16631135	76	1
VF16630192	44	14	VF16630646	27	19	VF16630743	72	23	VF16631181	67	47
VF16630194	44	15	VF16630647	26	20	VF16630744	71	30	VF16631181	74	36
VF16630196	44	16	VF16630647	27	20	VF16630744	72	30	VF16631182	1	24
VF16630200	44	18	VF16630655	1	4	VF16630745	74	37	VF16631184	82	20.1
VF16630216	53	10	VF16630657	35	23.1	VF16630746	74	12	VF16631186	74	21.1
VF16630217	53	12	VF16630658	35	23	VF16630757	49	13	VF16631187	71	18.1
VF16630219	51	49	VF16630682	71	3	VF16630766	71	24	VF16631187	72	18.1
VF16630219	53	13	VF16630682	72	3	VF16630766	72	24	VF16631220	82	2.1
VF16630231	28	13	VF16630684	71	5	VF16630767.01	71	33	VF16631248	65	21.1
VF16630232	10	6	VF16630685	71	2	VF16630767.01	72	33	VF16631249	64	10
VF16630234	49	8.2	VF16630685	72	2	VF16630768.01	71	33	VF16631263	1	2.1
VF16630236	49	1	VF16630686	71	18	VF16630768.01	72	33	VF16631271	25	19
VF16630237	49	42.1	VF16630686	72	18	VF16630888	33	52.1	VF16631272	25	6
VF16630254	29	15	VF16630690	74	3	VF16630889	33	52.2	VF16631273	25	29
VF16630283	55	4	VF16630695	74	2	VF16630900	33	52.3	VF16631279	94	9.1
VF16630383	5	1	VF16630700	74	7	VF16630964	81	22	VF16631291	40	27
VF16630385	90	6	VF16630705	74	1	VF16630966	67	27	VF16631340	47	1.1
VF16630393	58	26	VF16630706	74	10	VF16630966	71	28	VF16631340	48	1
VF16630394	8	18	VF16630707	74	11	VF16630966	72	28	VF16631346	47	11.1
VF16630397	8	1	VF16630709	71	17	VF16631049	38	40	VF16631346	48	9
VF16630397	11	9.1	VF16630709	72	17	VF16631049	41	6	VF16631347	47	13.1
VF16630397	21	1	VF16630710	74	8	VF16631123	35	12	VF16631347	48	10
VF16630398	57	3.1	VF16630716	74	4	VF16631123	36	64	VF16631420	85	15
VF16630398	59	1	VF16630721	74	23	VF16631123	37	12	VF16631427	70	2
VF16630487	52	23	VF16630730	73	1	VF16631123	40	11	VF16631429	70	5
VF16630506	26	6	VF16630734	74	27	VF16631123	41	21	VF16631430	70	1



Feedex 360 T / Part No Index

Part No.	Page	Pos No	Part No.	Page	Pos No
VF16631460	56	2	WA135895	5	28
VF16631478	56	3.1	WA135897	4	29
VF16631482	16	4	WA135897	5	29
VF16631486	17	16.1	WA153207	4	22
VF16631491	55	2	WA153207	5	22
VF16631491	57	2.1			
VF16631687	88	19			
VF16631815	1	25.1			
VF16631868	71	34			
VF16631868	72	34			
VF16631886	11	43.2			
VF16631886	19	1			
VF16631919	88	5			
VF16631920	85	17			
VF16635132	66	6.1			
VF16635132	74	32.1			
VF16635241	16	1			
VF16635245	64	24			
VF16635247	64	25			
VF16635249	64	29			
VF16635269	16	25			
VG35.06.70	4	23			
VG35.06.70	5	23			
VG63.12.01	4	25			
VG63.12.01	5	25			
VG85.01.02	4	51			
VNB3469202	16	8			
WA116565	5	4			
WA116566	5	5			
WA129948	5	51			
WA135075	4	21			
WA135075	5	21			
WA135895	4	28			



Feedex 360 T

1366 < Mach. ID <=

Maschinenfabrik Stolpen GmbH
Pirnaer Landstraße 24
D-01833 Stolpen
Germany
+49 35973 2240
+49 35973 22414

© Kverneland Group

All rights reserved. No parts of this book may be reproduced, stored in a database or retrieval system, or published in any form or in any way, electronically, mechanically, optically, by print, photo print, microfilm (including micro and macro fiche), or any other means, including all video and CD systems, without prior written permission from the publisher.

Print date: 2019-04-24

