

Ersatzteilliste

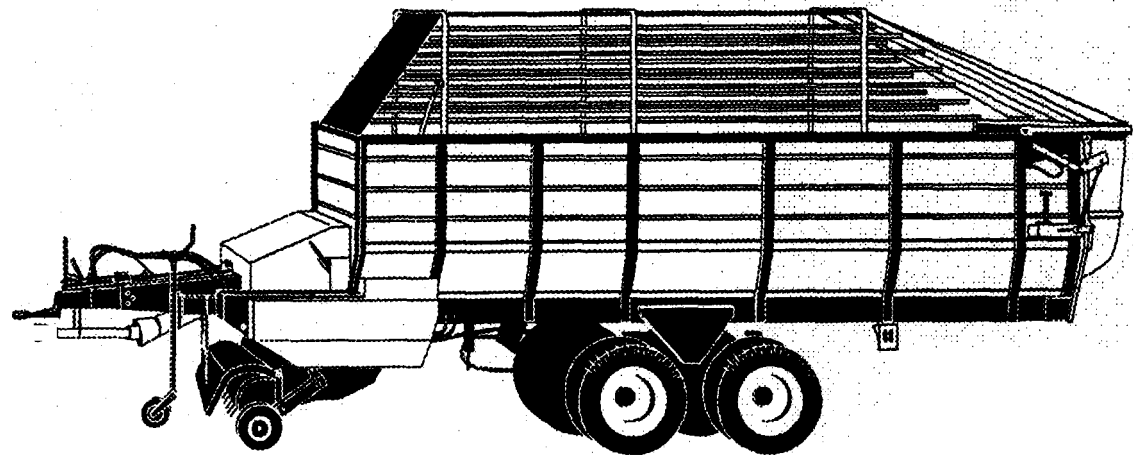

Stand 04/2003

Im Garantiefall unbedingt beachten!

Sehr geehrter Kunde,

Die Mitarbeiter der **Maschinenfabrik Stolpen GmbH** haben bei der Fertigung des Produktes mit großer Sorgfalt gearbeitet. Trotzdem, dass wissen Sie als Praktiker, sind Fehler niemals vollständig auszuschließen. Um auftretende Probleme richtig zu analysieren und für die Zukunft auszuschließen genügt es jedoch nicht in jedem Fall wenn Sie nur das defekte Bauteil reklamieren. Wir benötigen die vollständige Baueinheiten. Das trifft auch auf unsere Lieferanten zu, die spezielle Baugruppen für uns fertigen.

Bitte beachten Sie bei den folgenden Bauteilen, dass im Garantiefall stets die komplette Einheit reklamiert und gewechselt wird:

- **Getriebe**
- **Hydraulikventile**
- **Hydraulikmotor**
- **Hydraulische Steuerung**
- **Hydraulikzylinder**
- **Elektrische Steuereinheiten**
- **Stützfüße und Stützräder**
- **Druckluftzylinder**
- **ALB**

Nach Reparaturversuchen oder bei demontierten Einheiten erlischt Ihr Garantieanspruch !

Wir hoffen sehr das Sie diese Option nicht in Anspruch nehmen müssen und wünschen Ihnen mit unserem Produkt viel Erfolg und Freude bei der Arbeit !

Stolpen, 10.10.2003

Jens Kröhnert
Geschäftsführer
Maschinenfabrik Stolpen GmbH
www.mafa-stolpen.de

B01

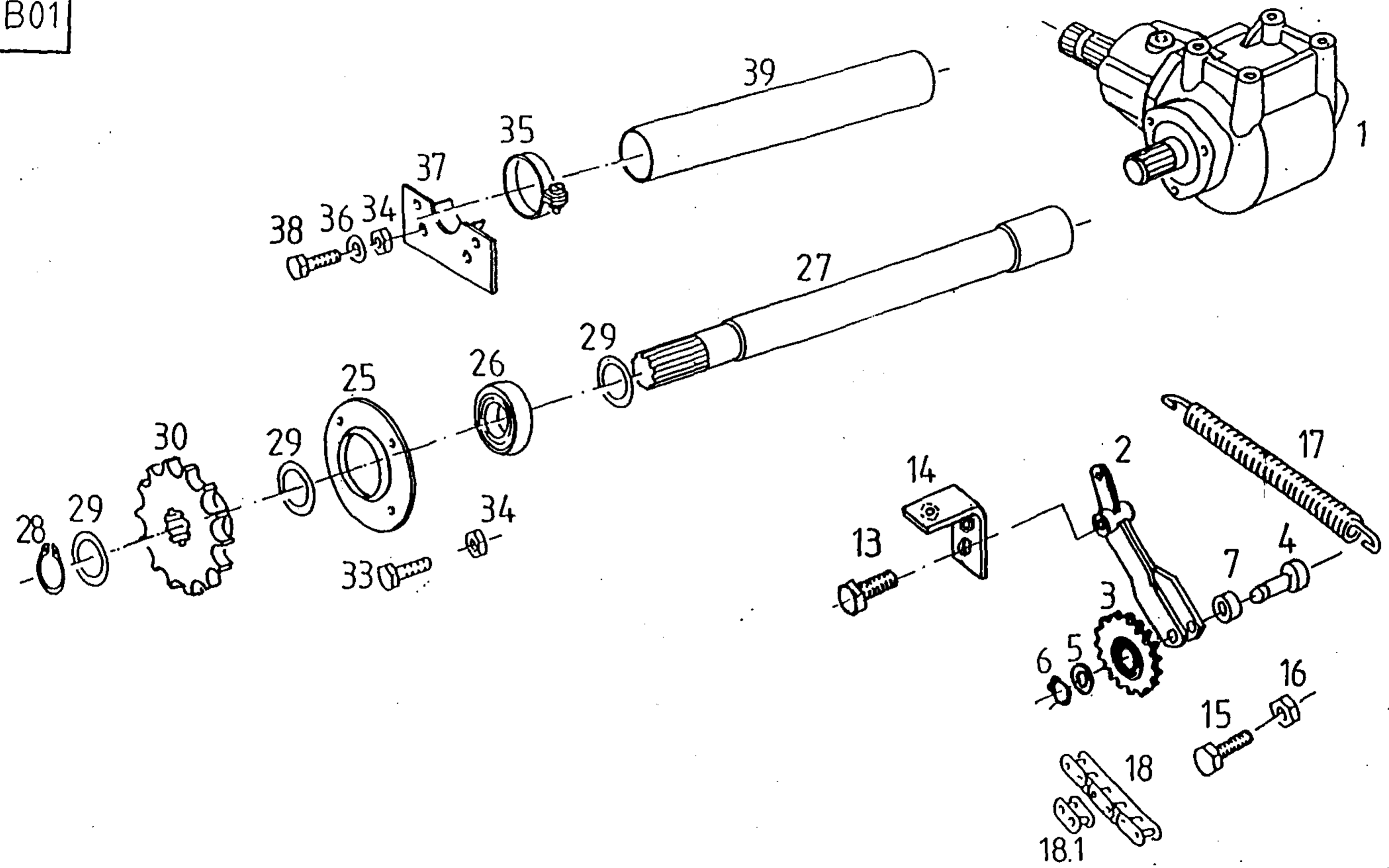

			Antrieb	drive	Pieces de command	Piezas accionamiento
Pos.	Teile-Nr.	Menge	Benennung	Description	Designation	Denominacion
Pos.	Part.Nt.	Qty.				
Pos.	Piece No.	Qte.				
Pos.	Pieza No.	Cat.				
1	1661 0801	1	Winkelgetriebe	ANGLE DRIVE	ENGRENAGE ANGLL.	ENGRANAJE ANGULAR
2	1651 6640	1	Kettenspanner gsw.	TENSIONER	TENDEUR DE CHAINE	TENSOR CADENA
3	1651 3217	1	Kettenrad Z=13	SPROCKET	ROUE A CHAINES	RUEDA CADENA
4	1663 0655	1	Bolzen	PIN/BOLT/STU	BOULON/AXE	BULON
5	0621 4588	1	Stützscheibe 25x35x2	SPACER	RONDELLE	ARANDELA
6	0110 7737	1	Sich.Ring 25 x 1,2	CIRCLIP	CIRCLIP	ANILLO DE SEGURIDAD
7	0658 0174	2	Abstandring	SPACER	RONDELLE	DISTANCIADOR
13	1661 0895	1	SHR. M2091 DIN 931	HEX.BOLT	VIS 6 PANS	TORNILLO HEXAGONAL
14	1651 8921	1	WINKEL GSW.	ANGLE PLATE	EQUERRE	ANGULO
15	0111 2697	1	SHR. M16x50D933	hex.head screw	vis tete 6-pans	tornillo hexagonal
16	0111 2886	1	MU.M16x50D933	HEX.NUT	ECROU 6-PANS	TUERCA HEXAGONAL
17	0114 2492	1	Zugfeder 5x24x376	DRAW SPRING	RESSORT TRACTION	RESORTE TRACTION
18	1663 0378	1	Kette ANSI 100Hx63S	ROLLER CHAIN	CHAINE A ROULEAUX	CADENA DE RODILLOS
18.1	0139 7747	0	Glied S-ANSI100HE-9	chain lock	attache rapide	eslabon de cierre
25	0621 5785	1	BLECHGEH.	BEARING FLANGE	BRIDE POUR COUSS.	BRIDA PARA COJ.
26	0621 5768	1	Einstellager 208	GR.BALL BEARING	ROULEU.R.A BILLES	RODAMIENTO
27	1663 0275	1	ANTRIEBSWELLE GSW.	DRIVE SHAFT	ARBRE DE COMMANDE	EJE MOTRIZ
28	0110 7755	1	Sich-Ring 40x1,75	CIRCLIP	CIRCLIP	ANILLO DE SEGURIDAD
29	0113 7379	5	Stütزش. 40x50x2,5	SHIM	RONDELLE D'APPUI	ARANDELA APOYO
30	1651 3003	1	KETTENRAD GSW.	SPROCKET	ROUE A CHAINES	RUEDA CADENA
33	0111 2529	2	Shr. M12x30 D933	hex.head screw	vis tete 6-pans	torn.cab.hexagonal
34	0620 9769	4	Mu. M12 8A3C	Lock nut	Ecrou de securite	Tuerca de seguridad
35	0112 8272	1	Schelle 50-70/12	HOSE CLIP	COLLIER SERRAGE	ABRAZADERA MANGLIER
36	0621 4207	2	Scheibe 13x24x2,5A3C	WASHER	RONDELLE	ARANDELA
37	0655 0405	1	LAGERPLATTE GESCHW.	SUPPORTPLATE	PLAQUE SUPPORT	PLACA SOPORTE
38	0111 2538	2	Shr. M 12x35 88A3C	Hex.head screw	Vis tete 6-pans	Tornillo hexa onal
39	1663 0379	1	SCHUTZROHR	PROTECTING TUBE	TUBE DE PROTECTION	TUBO DE PROTECTION

Bildtafel B01

Diagram
Diagramme
Diagrama
Bemerkungen
Notes
Notes
Notas

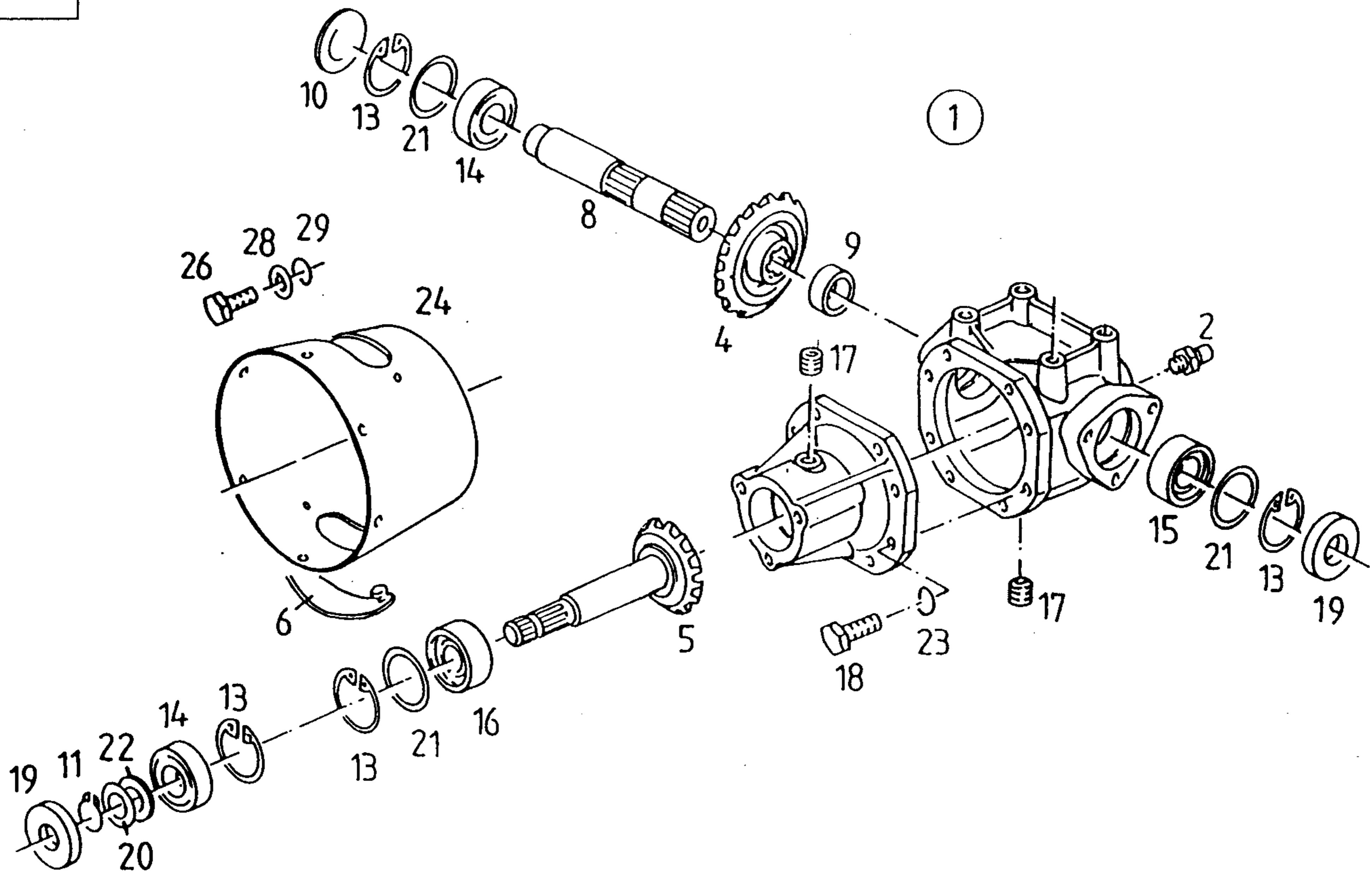

Bildtafel B02

Diagram
Diagramme
Diagrama
Bemerkungen
Notes
Notes
Notas

			Winkelgetriebe	angular gear	engranaje angular	engranaje angular	
Pos.	Teile-Nr.	Menge	Benennung	Description	Designation	Denominacion	
Pos.	Part.Nr.	Qty.					
Pos.	Piece No.	Qte.					
Pos.	Pieza No.	Cat.					
1	1661 0801	1	WINKELGETRIEBE	ANGLE DRIVE	ENGRENAGE ANGLL.	ENGRANAJE ANGULAR	
2	0658 5321	1	Entlüftungsventil	VENTING SCREW SCREW	VIS DEGAGEMENT D'AIR	TORNILLO DE PURGA	
4	1661 1262	1	Kegelrad	BEVEL GEAR	ENGREN CONIQUE	RUEDA CONICA	
5	1661 1261	1	Ritzelwelle	PINION SHAFT	ARBRE DE PIGNON	EJE PINON	
6	0655 4188	2	SCHUTZDECKEL	COVER	COUVERCLE	TAPA	
8	0629 5430	1	ABTRIEBSWELLE	OUTPUT SHAFT	ARBRE SECONDAIRE	EJE SECUNDARIO'	
9	11439 109 110	1	BUCHSE	BUSH	DOUILLE	CASQUILLO	
10	0655 7587	1	Verschlußkappe 80x8	CAP	CHAPEAU	SOMBRETERE CIERRE	
11	0113 7321	1	Sich-Ring 40x2,5	RING	BAGUE	ANILLO	
13	0110 7855	4	Sich-Ring 80x2,5	CIRCLIP	CIRCLIP	ANILLO DE SEGURIDAD	
14	0110 9063	2	Ri-Lager 6208	GROOVE BALL BEARING	ROULEM.R.A BILLES	COJ.DE BOLAS RAN.	
15	0110 9958	1	Kr.-Lager 30208 D720	TAPER R. BEARING	ROULEM. A ROULEAUX	RODAM. DE RODILLOS	
16	0111 0002	1	KR-LAG.32208	TAPER R. BEARING	RO LEM. A ROULEAUX	RODAM. DE RODILLOS	
17	0111 0415	3	V-Schr. M 16x1,5	SCREW PLUG	BOUCHON FILETE	TAPON Roscado	
18	0111 2429	8	Shr. M 10x30 88Á3C	HEX. HEAD SCREW	VIS TETE 6-PANS	TORN.CAB. HEXAGONAL	
19	0117 2407	2	WDR-BA 40x80x10	RAD.SEAL RING	JOINT RADIAL	JUNTA RADIAL	
20	0621 4490	0	PASS-SCHB. 40X50X0,1	SPACER	RONDELLE D'EPAISSEUR	ARANDELA DE ESPESOR	
20.1	0621 4 491	0	PASS-SCHB. 40x50x0,3	SPACER	RONDELLE D'EPAISSEUR	ARANDELA DE ESPESOR	
20.2	0621 4492	0	PASS-SCHB. 40x50x0,5	SPACER	RONDELLE D'EPAISSEUR	ARANDELA DE ESPESOR	
20.3	0113 7379	0	Stützschr. 40x50x2,5	SHIM	RONDELLE D'APPUI	ARANDELA APOYO	
21	0621 4521	0	PASS-SCHB.63x80x1	SPACER	RONDELLE D'EPAISSEUR	ARANDELA DE ESPESOR	
21.1	0621 4520	0	PASS-SCHB. 63x80x0,5	SPACER	RONDELLE D'EPAISSEUR	ARANDELA DE ESPESOR	
21.2	0621 4519	0	Paßscheibe 63x80x0,3	SPACER.	RONDELLE D'EPAISSEUR	ARANDELA DE ESPESOR	
23	0110 2800	8	Fedrg. A10 DIN 128	SPRING WASHER	RONDELLE ELASTIQUE	ARANDELA ELÁSTICA	
24	0657 8978	1	SCHUTZTOPF M.DECKEL	PROTECTING CUP	POT DE PROTECTION	COPA DE PROTECTION	
26	0111 2307	3	SHR. M 8x16 D933	HEX. HEAD SCREW	VIS TETE 6-PANS	TORN.CAB. HEXAGONAL	
28	0621 4246	3	SCHEIBE 9X18X2 A3C	WASHER	RONDELLE	ARANDELA	
29	0110 2799	3	Federring A8 DIN 128	SPRING WASHER	RONDELLE ELASTIQUE	ARANDELA ELÁSTICA	

B 03

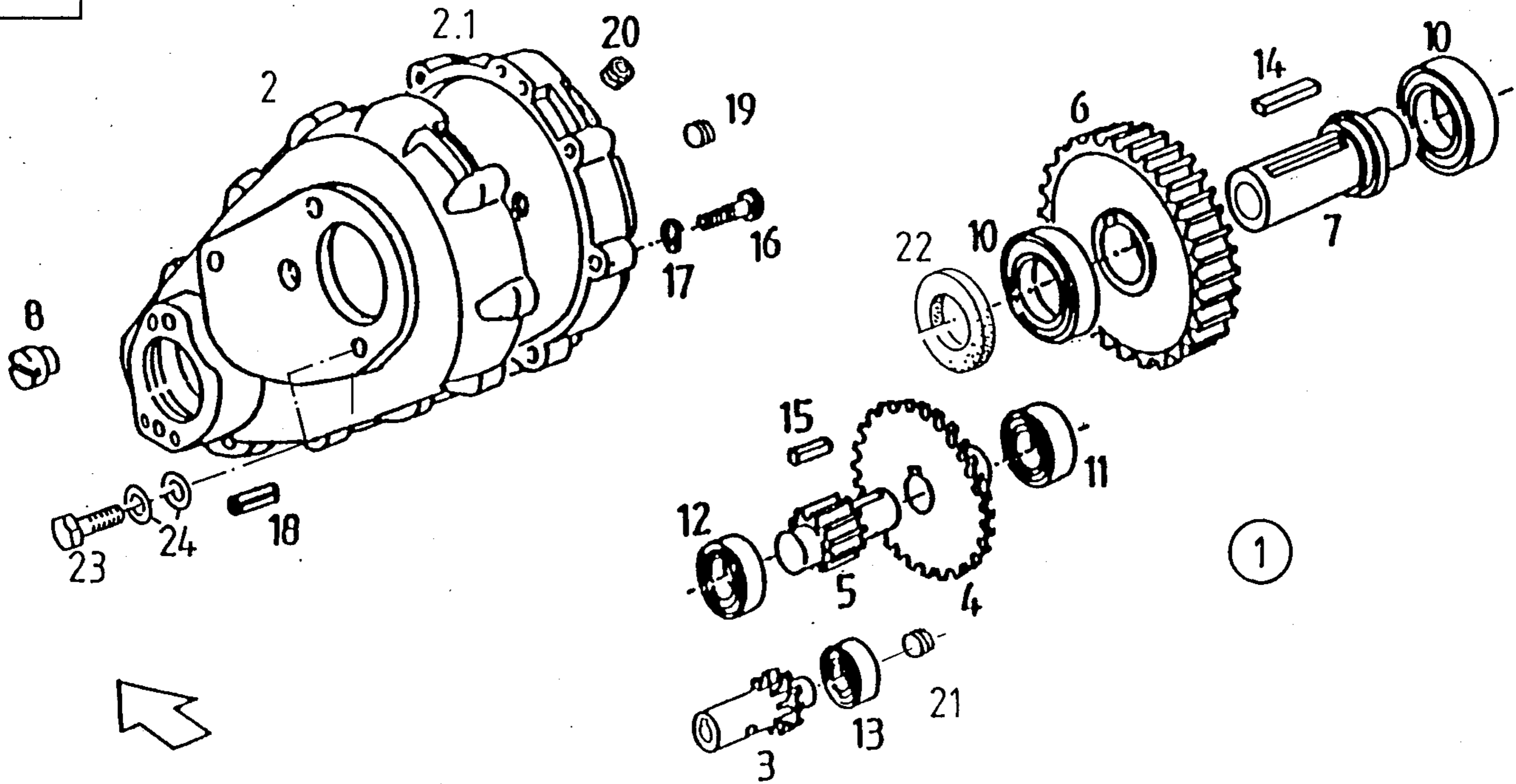

Stirnradgetriebe
für Kratzboden

sur gear
floor

engrenage droit
fond mouv

engr.con dientes rec
fondo rascad

Bildtafel B03

Diagram
Diagramme
Diagrama

Pos. Pos. Poe. Pos.	Teile-Nr. Part.Nr. Piece No. Pieza No.	Menge Qty. Qte. Cat.	Benennung	Description	Designation	Denominacion	Bemerkungen Notes Notes Notas
1	1661 3261	1	Stirnradgetriebe	SPUR-GEARING	ENGRENAGE ROUES	ENGRANAJE RECTO	
2	1661 1297	1	Gehäuse-Unterteil	Half-housing	Demi-carter	Mitad-caja	
2.1	1651 3607	1	GEHAEUSE-OBERTEIL	HALF-HOUSING	DEMI-CARTER	MITAD CAJA	
3	1661 1266	1	Ritzelwelle Z=20	PINION SHAFT	ARBRE DE PIGNON	EJE PINON	
4	1661 1267	1	Stirnrad Z=55	SPUR GEAR	ROUE DROIT	RUEDA RECTA	
5	1651 3621	1	RITZELWELLE Z=12	PINION SHAFT	ARBRE DE PIGNON	EJE PINON	
6	1651 3622	1	STIRNRAD Z=46	SPUR GEAR -	ROUE DROIT	RUEDA RECTA	
7	1661 1299	1	Hohlwelle	Quill shaft	Arbre creux	MUNON/ESPIGA	
8	1651 3624	1	Zapfen	PIN/SPIGOT	TENON/PIVOT/TOURIL	Eje hueco	
10	0139 7576	2	Ri-Lager 6012 -2RS	BALL BEARING	ROUL RAINURE BILLE	COJ.BOLAS FIJO	
11	0110 8981	1	Ri-lager 6009	GR. BALL BEARING	ROULEM. R. A BILLES	COJ. DE BOLAS RAN.	
12	0110 9057	1	RI-LAGER 6207	GR. BALL BEARING	ROULEM. R. A BILLES	COJ. DE BOLAS RAN.	
13	0110 9044	1	RI-LAGER 6205	GR. BALL BEARING	ROULEM. R. A BILLES	COJ. DE BOLAS RAN.	
14	0139 7575	1	PASSFED.B18X11X	KEY	CLAVETTE ENCASTRES	LENGÜETA AJUSTE	
15	0627 2542	1	Passfeder B 8x7x28	KEY	CLAVETTE ENCASTRES	LENGÜETA AJUSTE	
16	0112 6929	10	SHR.M10X 50D912	CHEESE-HEAD SCREW	VIS TETE CYLINDR.	TORN.CBZA.CILIND.	
17	0110 2800	10	Fedrg. A10 DIN 128	SPRING WASHER	RONDELLE ÉLASTIQUE	ARANDELA ELASTICA	
18	0139 7859	2	Spannsift 12x40 DIN	DOWEL PIN	GOUPILLE SERRAGE	PERNO FIADOR	
19	1661 1268	1	VSHR.M22x1,5 D906	SCREW PLUG	BOUCHON FILETS	TAPON ROSCADO	
20	0111 0415	1	V-Schr. M 16x1,5	SCREW PLUG	BOUCHON FILETÉ	TAPON ROSCADO	
21	0112 4441	1	V-SCHR.M12x1,5DIN906	SCREW PLUG	BOUCHON FILETÉ	TAPON ROSCADO	
22	1661 1298	1	WDRING 60X85X8 BA	SEAL RING	BAGUE ETANCHEITE	ANILLO JUNTA	
23	0117 7887	3	SHR. H2091 DIN 933	HEX.BOLT	VIS 6 PANS	TORNILLO HEXAGONAL	
24	0621 4217	6	Scheibe 17,0 A3C	WASHER	RONDELLE	ARANDELA	

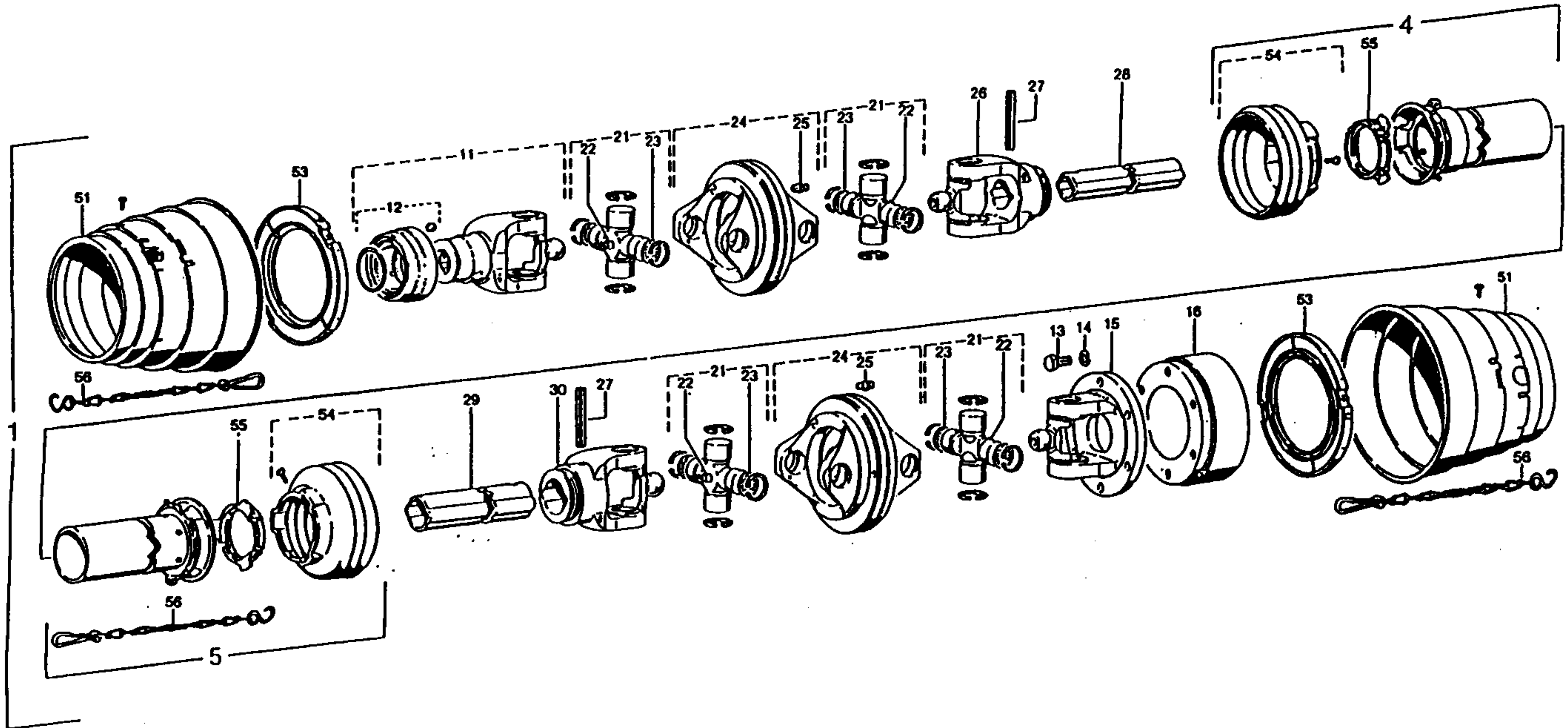

Gelenkwelle WWZ mit
Nockenschaltkupplung
2000 Nm

univ.prop.shaft with cam
clurch

arbre a cardans avec
manchon a coquil

arbol a cardan con
acoplam.manguito

Bildtafel B07

Diagram
Diagramme
Diagrama
Bemerkungen
Notes
Notes
Notas

Pos.	Teile-Nr.	Menge	Benennung	Description	Designation	Denominacion
Pos.	Part. Nr.	Qty.				
Pos.	Piece No.	Qte.				
Pos.	Pieza No.	Cat.				
1	1663 0383	1	GELENKW. WWZ 2480-1	UNIV PROP SHAFT	ARBRE A CARDANS	ARBOL A CARDAN
4	1651 8318	1	A-Schutzhälfte	PROTECTION HALF	MOITIE PROTECTION	MEDIO PROTECTION
5	1651 8319	1	I-SCHUTZHAELFTE	PROTECTION HALF	MOITIE PROTECTION	MEDIO PROTECTION
11	1660 2170	1	QS-GABEL KPL.	CLEVIS/FORK	FOURCHETTE	HORQUILLA
12	0658 6171	1	VERSCHLUSS KPL.	Fastener Lock	FERMETURE	CIERRE
13	0110 2701	6	Shr. M 12x30 DIN933	HEX HEAD SCREW	VIS A TETE 6 PANS	TORNILLO HEXAGONAL
14	0110 2801	6	Fedrg. A12 D128 A3C	Spring washer	RONDELLE ELASTIQUE	ARANDELA ELÁSTICA
15	1651 3601	1	FLANSCHGABEL	FLANGED FORK	CHAPE AVEC BRIDE	HORQUILLA C.BRIDA
16	1660 2171	1	Nockenschaltkupplung	COUPLING	MANCHON A COQUIL	ACOPLAM.MANGUITO
21	0658 2339	4	KREUZGARNITUR	JOINT CROSS	CROISILLON	CRUCETA
22	1650 4065	4	KEGEL-SCHMIERNIPPEL	GREASE NIPPLE	GRAISSEUR	ENGRASADOR
23	1650 0120	8	Ronde	Plate	RONDELLE	Disco
24	0658 6755	2	DOPPELGABEL	Double yoke	Machoire double	Articulado doble
25	0112 0693	2	Schmiernippel AM HI	GREASE IPPLE	GRAISSEUR A PRESSION	ENGRASADOR
26	0658 2340	1	RILLENGAB	FORK	CHAPE	HORQUILLA
27	0115 7385	2	SP.ST.D1481-10X80	DOWEL PIN	GOUPILLE SERRAGE	PERNO FIADOR
28	1651 3603	1	PROFILROHR	PROFILE TUBE	TUBE PROFILE	TUBO PERFILADO
29	1651 3604	1	PROFILROHRAG-L-710	PROFILE TUBE	TUBE PROFILE	TUBO PERFILADO
30	1651 3605	1	RILLENGABEL	FORK	FOURCHE	HORQUILLA
51	1651 3615	2	SCHUTZTRICHTER	GUARD	TOLE DE PROTECTION	CHAPA DE PROTECC.
53	1651 3616	2	GLEITRING	SLIDING RING	ANNEAU DE GLISSEMT	ANILLO DESLIZANTE
54	1651 3617	2	SCHUTZTRICHTERN=RP3	GUARD	TOLE DE PROTECTION	CHAPA DE PROTECC.
55	0658 1954	2	Gleitring	RING	BAGUE	ANILLO
56	1651 3618	3	HALTEKETTE	CHAIN	CHAINE	CADENA

B 09

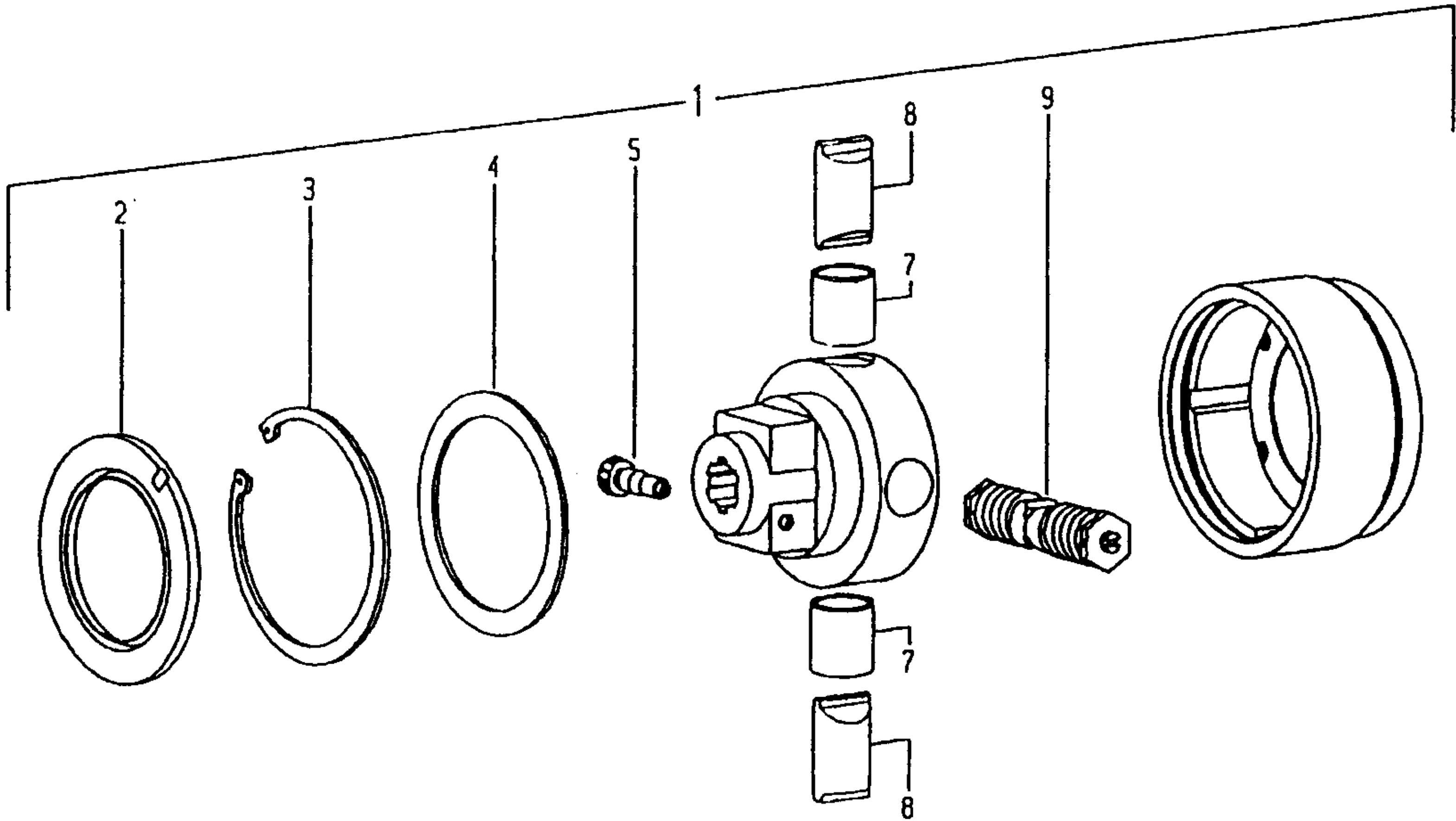

Nockenschaltkupplung cam clutch manchon a coquil acoplam. manguito

Bildtafel B09

Diagram
Diagramme
Diagrama
Bemerkungen
Notes
Notes
Notas

Pos.	Teile-Nr.	Menge	Benennung	Description	Designation	Denomination
Pos.	Part.Nr.	Qty.				
Pos.	Piece No.	Qte.				
Pos.	Pieza No.	Cat.				
1	1660 2171	1	Nockenschaltkupplung	COUPLING	Manchon a coquil	ACOPLAM.MANGUITO
2	1651 3610	1	DICHTRING 152,5x99x8	O-SEAL	ANNEAU TORIQUE	ANILLO JUNTA REDON
3	0139 7558	1	SICH-RING 150X4	CIRCLIP	CIRCLIP	CIRCLIP
4	0139 7559	1	Stü.Schb.120x150x3,5	SHIM	RONDELLA APPOYO	Arandela Apoyo
5	1660 2177	1	KLEMM-KONUS CC1 3/8-1	CONE	CONE	CONO
7	0655 4375	2	BUCHSE	BUSH	MANCHON	MANGUITO,
8	0655 4371	2	NOCKEN	CAM	CAME	LEVA
9	1651 3611	1	FEDERPAKET MONT.	spring pack assembly	block ressort cpl.	paquete muelle cpl.

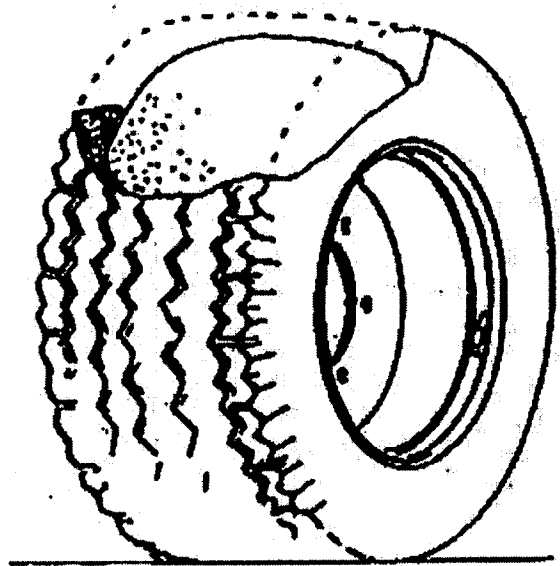
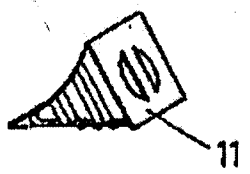
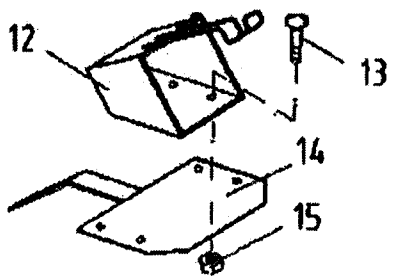

1 2 3 4

Pos.	Teile-Nr.	Menge	Benennung	Deskription	Designation	Denominacion	
Pos.	Part.Nr.	Qty.					Bildtafel C08
Pos.	Piere No.	Cat.					Diagram
Pos.	Pieta No.	Qte.					Diagramme
							Diagrama
							Bemerkungen
							Notes
							Notes
							Notas
			Reifen	tyre	pneu	neumatico	
1		4	REIFEN 500/50-17 14PR TYRE		PNEUMATIQUE	NEUMATICO ARO RUED	
2		4	Felge 16x17 ET-35				
3		4	Schlauch 19,0/45-17	HOSE	FLEXIBLE	MANGUERA	
4		4	VENTIL 43 GS 16	VALVE	SOUPAPE	VALVULA	
11	1663 0072	2	Unterlegkeil 114,1	block	cale	boque de base	
12	1663 0070	2	Halter	retainer	support a droite	soporte	
13	0113 7624	8	Shr. M 8x25 8.8 A3C	SCREW	VIS	TORNILLO	
14	1663 0069	2	Halter gsw.	retainer	support a droite	soporte	
15	0110 4944	8	Sich. Mu. M8 8A3C	LOCK NUT	ECROU DE SECURITE	TUERCA DE SEGURIDAD	
17	1661 5023	4	Reifen 555/45-17 146	tyre	pneumatique	pneumatico aro rued	für 65 km/h

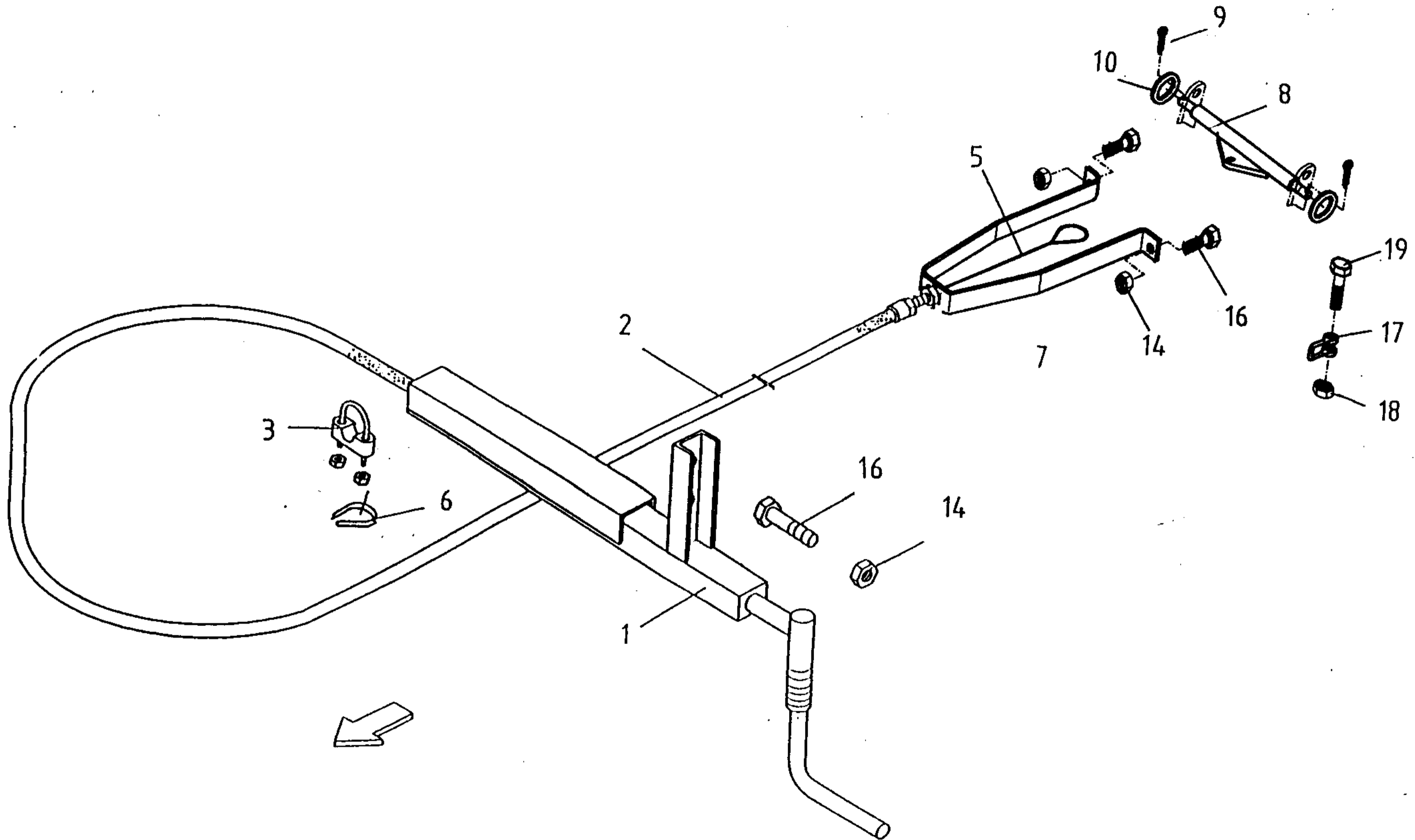

Handbremse-Tandem-
achse gefedert 4 Bremsen
12To. Druckluft

Handbrake-tand.axle
spring born 4 brakes
press air

frein a main essieu
timon.tandem 4 frein
press air

freno de mando-eje tandem
en muelles 4 frenos press
aire

Bildtafel C 10

Diagram
Diagramme
Diagrama

Bemerkung
Notes
Notes
Notas

Pos.	TeileNr.	Menge	Benennung	Description	Designation	Denomination	
Pos.	Part. Nr.	Qty.					
Pos.	Piece No.	Qte.					
Pos.	Pieza No.	Cat.					
1	1651 6507	1	Feststellbremse gsw.	Parking Brake	Frein D'Arret	FRENO ESTACIONAM.	
2	1663 0488	1	Bowdenzughülle	CABLE HOSE	GAINÉ DECABLE	VAINA DE CABLE	
3	0113 6686	2	Seilklemme S 5	CLAMPING PIECE	COLLIER	ABRAZADERA	
5	1651 8259	1	Bremsseil Länge 1600	BRAKE CABLE	CABLE DE FRENO	CABLE FRENO	
6	0113 9169	1	Kausche B 5	THIMBLE	COSSE	OJAL DE CABLE	
7	1663 0369	1	Bügel	YOKE/RETAINER	ETRIER	ESTRIBO	
8	1663 0368	1	Ausgleichswaage gsw.				
9	0110 6447	2	Splint 4x20				
10	0621 4207	2	Scheibe 13x24x2,5	WASHER	RONDELLE	ARANDELA	
14	0620 9778	4	Sich.Mu.M12	HEX. HEAD SCREW	VIS TETE 6-pans	TORN.CAB.HEXAGONAL	
16	0111 2529	4	Shr.M12x30	Hex.head screw	VIS TETE6-PANS	Tornillo hexagonal	
17	0112 1829	1	Schaeckel				
18	0620 9778	1	Sich.Mu.M12	HEX. HEAD SCREW	VIS TETE6-PANS	TORN.CAB.HEXAGONAL	
19	0111 1486	1	Shr.M12x508.8	Hex.head screw	Vis tete6-pans	Tornillo hexagonal	

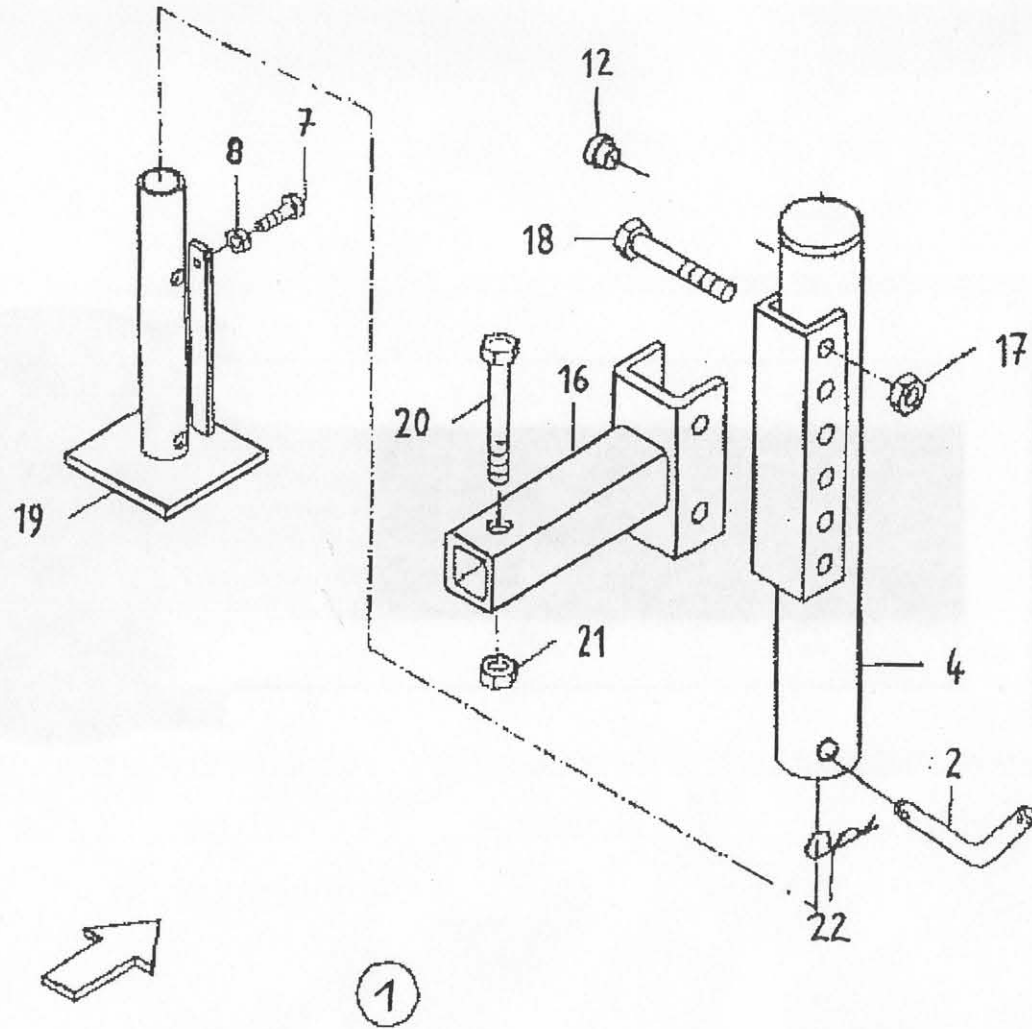

Stützfuß				support	pied de support	pata apoyo	Bildtafel C15
Pos.	Teile-Nr.	Menge	Benennung	Description	Designation	Denominacion	Diagram
Pos.	Part.Nr	Qty.					Diagramme
Pos.	Piere No	Qte.					Diagrama
Pos.	Pieza No.	Cat.					Bemerkungen
							Notes
							Notes
							Notas
1	1663 0760	1	Stützfuß	Prased parts	pieces supprimees	bulon suprimidas	
2	1661 4473	1	Bolzen	bolt	boulon	bulon	
4	1663 0853	1	Außenrohr kpl.	external tube	tube exterieur	tubo exterior	
7	0111 2307	1	Shr.M 8x16 D933	HEX.HEAD SCREW	VIS TETE 6-PANS	TORN.CAB. HEXAGONAL	
8	0111 2824	1	Mu. M 8 8A3C	HEX. NUT	ECROU 6-PANS	TUERCA HEXAGONAL	
12	1651 4101	1	STOPFEN	PLUG	BOUCHON	TAPON	
16	1661 4478	1	Gegenhalter	retainer	support	soporte	
17	0620 9774	2	Mu.M20 DIN985	LOCK NUT	ECROU DE SURETE	TU RCA DE SEGURIDAD	
18	0113 9339	2	SHR.M20X110D931	HEX.BOLT	VIS 6 PANS	TORNILLO HEXAGONAL	
19	1663 0794	1	Fuß kpl.	support	pied de support	pata apoyo	
20	0111 1941	1	SHR M 16x120 8.8 A3C	HEX.BOLT	VIS PANS	TORNILLO HEXAGONAL	
21	0112 7856	1	Si.Mu.M16 D985 8A3C	LOCK NUT	ECROU DE SECURITE	TUERCA DE SEGURIDAD	
22	0621 5671	1	FED.STECK.4 LIEFV.	PIN	BROCHEPASADOR		

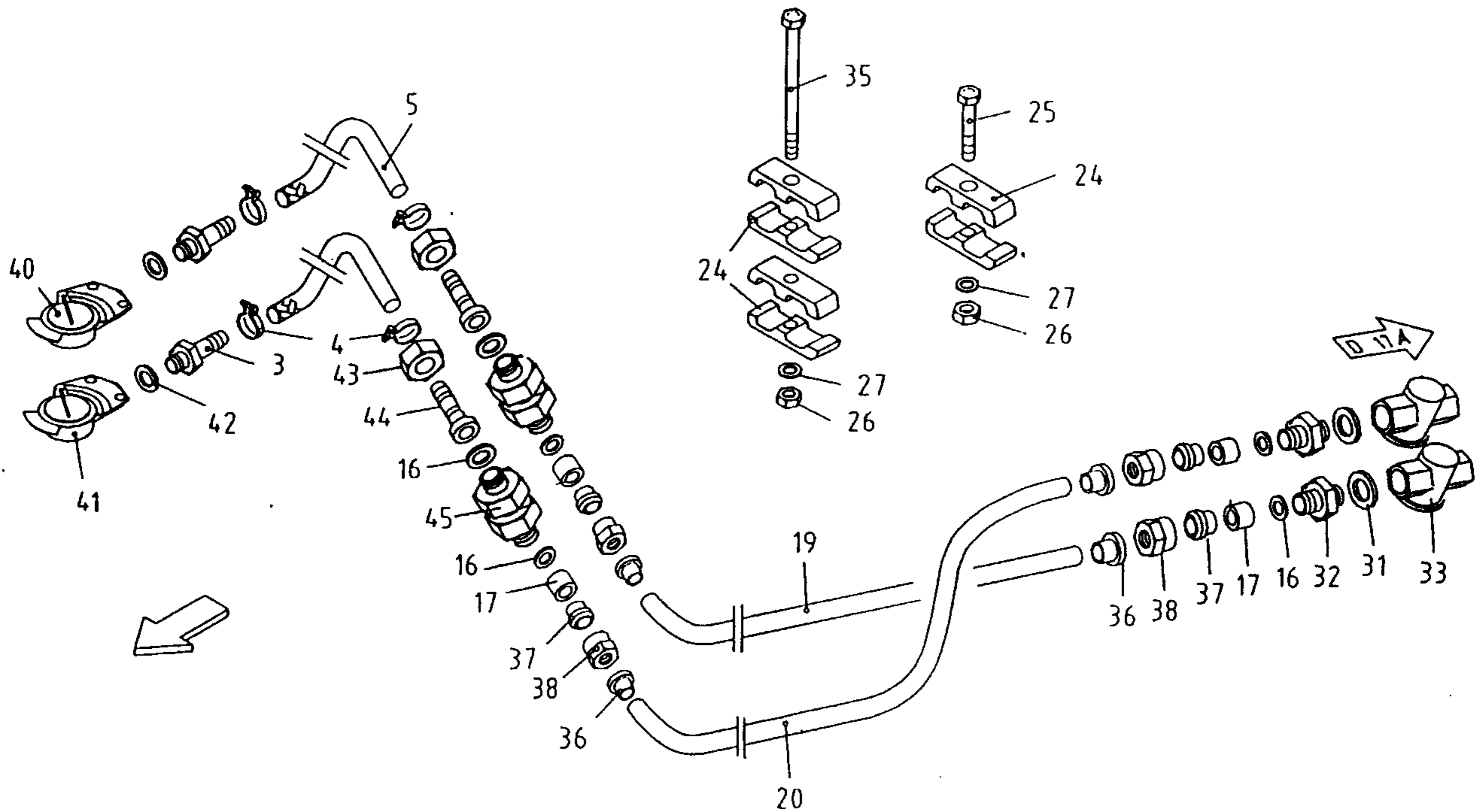

Druckluftanlage

single axle

frein press. air
essieu singlefreno airo comprim.
eje single**Bildtafel D01**Diagram
Diagramme
Diagrama

Bemerkungen

Notes

Notes

Notas

Pos.	Teile-Nr.	Menge	Benennung	Description	Designation	Denominacion
Pos.	Part.Nr.	Qty.				
Pos.	Piece No.	Qte.				
Pos.	Pieza No.	Cat.				
3	0621 6771	2	Stutzen B 32020109	Socket/Adapter	Tubulure/Raccord	Tubuladura
4	0621 6772	4	Schl-Schelle	PIPE CLIP	COLLIER	ABRAZADERA
5	0655 8991	2	Bremsachlauch	BRAKE TUBE	CANALISATION DE	TUBERIA DE FRENO
16	0627 7296	6	Dichtring A12x19x1,5	SEALING	JOINT	JUNTA
17	0112 5146	6	Druckring	thrust ring	bague de butee	anillo presion
19	1663 0506	1	Kunststoffrohr	PLASTIC TUBE	TUBE PLASTIQUE	TUBO PLASTICO
20	1663 0507	1	Kunststoffrohr	PLASTIC TUBE	TUBE PLASTIQUE	TUBO PLASTICO
24	0657 8035	6	Rohrklemme 15/15	CLAP	COLLIER	ABRAZADERA
25	0112 2389	1	Shr.M6x35 8.8A3C	HEX.HEAD SCREW	VIS TETE 6-PANS	TORN.CAB.HAXAGONAL
26	0111 4357	3	Mu.M6 8A3C	LOCK NUT	ECROU DE SECURITE	TUERCA DE SEGURIDAD
27	0621 4189	3	Scheibe 6,4x18x2	WASHER	RONDELLE	ARANDELA
31	0111 8736	2	D-Ring	GASKET	JOINT	JUNTA
32	0114 2247	2	Stutzen	SOCKET/ADAPTER	TUBLURE/RACCORD	TUBULADURA
33	0655 8801	2	Leitungsfiter	FILTER	FILTRE	FILTRO
35	0112 6974	2	Shr.M6x65 D931	HEX.HEAD SCREW	VIS TETE 6-PANS	TORNILLO HEX.
36	0295 3369	4	E-hülse E15/12	PLUG-IN SLEEVE	DOUILLE A EMBOITMT	CASQUILLO ENCHUFE
37	0111 6626	4	Schneidring	CUTTING RING	ANNEAU TRANCHANT	ANILLO CORTANTE
38	0112 5152	4	Überwurfmutter	UNION NUT	ECROU-RACCORD	TUERCA EMPLAME
40	1663 0646	1	Kuppl.Kopf Brem.gelb			
41	1663 0647	1	Kuppl.Kopf Vorr.rot			
42	0621 6757	2	Dichtsatz			
43	0114 2083	2	Überwurfsmu. D3870-BLL15			
44	0112 1766	2	Schlauchstutzen			
45	0621 6763	2	Doppelstutzen 32018209			
46	0621 4307	4	Scheibe 3x38x3 A3C			

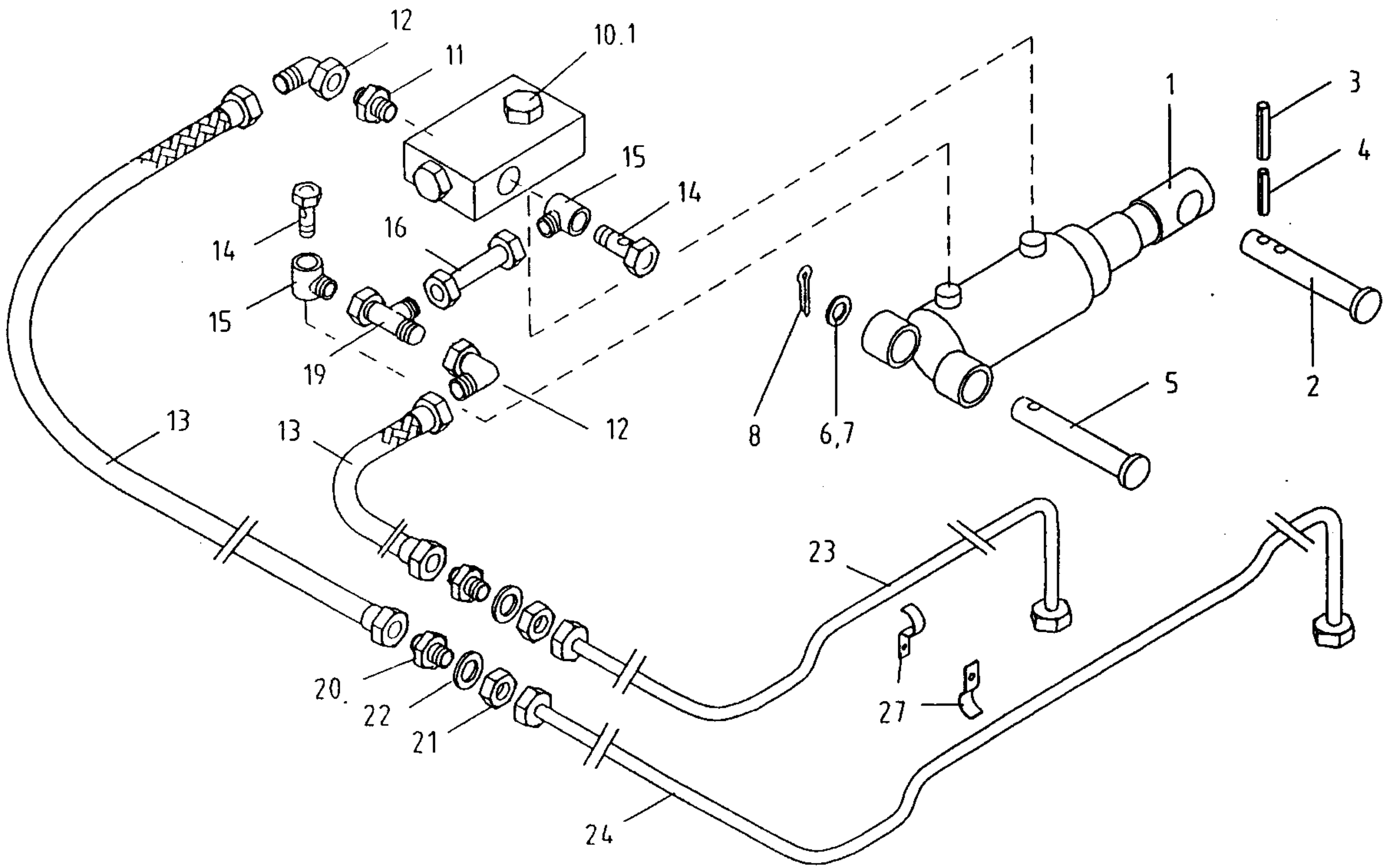

Hydraulikanlage für
hydr Knickdeichsel

for cranked drawbar

hydr.pour timon
articule

hidr.para timon
articulai

Bildtafel D 05

Diagram

Diagramme

Diagrama

Bemerkungen

Notes

Notes

Notas

Pos.	Teile-Nr.	Menge	Benennung	Description	Designation	Denominacion
Pos.	Part. Nr.	Qty.				
Pos.	Piece No.	Qte.				
Pos.	Pieza No	Cat.				
1	1663 0451	1	HYDR.ZYLINDER	HYDRAULIC CYLINDER	CYLINDRE HYDRAUL	CILINDRO HYDRAULIC
1.1	1663 0452	0	DICHTUNGSSATZ	SEALING SET	JEU DE JOINTS	LOTE JUNTAS
2	1651 5159	1	Bolzen 33x180	PIN/BOLT/STUD	BOULON/AXE	BULON
3	0113 6930	1	Sp.Stift 10x50 D1481	DOWEL PIN	GOUPILLE SERRAGE	PERNO FIADOR
4	0115 7345	1	Sp.Stift 6x50 D1481	DOWEL PIN	GOUPILLE SERRAGE	PERNO FIADOR
5	0139 7555	1	Bolzen B33H11xI90	PIN/BOLT/STUD	BOULON/AXE	BULON
6	0621 4238	1	Schb. 34,0 DIN1441	'KASHER/DISC/PLATE	RONDELLE/DISQUE	DISCO/ARANDELA
7	0621 4237	1	Schb. 33,5 X 50 X 2	'KASHER	RONDELLE	ARANDELA
8	0110 6500	1	Splint 8 x 50	SPLIT PIN	GOUPILLE FENDUE	PASADOR DE ALETAS
10	1651 5212	1	Zylinderanbauplatte	PLATE	PLAQUE	PLACA
10.1	1661 7328	1	Hohlschr. R1/4"x45	hollow bolt	vis creux	tornillo hueco
11	0114 1838	1	Nippel XGE 8-LR	SCREW-IN NIPPLE	TUBULURE A VIS	TUBULAD.ENROSCADA
12	0117 2986	2	Winkelstück X evW	ELBOW	RACCORD COUDE	TUBULADOR ANGULAR
13	0657 2762	2	HYDR.SCHLAUCH	HYDR.HOSE	CAN.HYDRAULIQUE	TUBO FLAX.HIDRAU.
14	0114 1296	2	Hohlschraube HS R	HOLLOW BOLT	VIS CREUSE	TORNILLO HUECO
15	0114 1295	2	Gehäuse XSWVE 8- LR	UNION	RACCORD	RACOR
16	1661 0812	1	HYDR.LEITUNG MONT.	HYDR.PIPE	CANALISATION HYDR.	TUBERIA HIDRAU.
19	0114 1654	1	Stutzen XEVL 8-L	T-UNION	RACCORD-T	RACOR-T
20	0112 3941	2	Schottstutzen	TWO-WAY CONNECTOR	AJUTAGE	RACOR MAMPARO
21	0112 1824	2	Mutter M14x1,5	HEX.NUT	ECROU 6 PANS	TUERCA HEXAGONAL
22	0621 4202	2	Schb.14x24x1,6 A3C	WASHER	RONDELLE	ARANDELA
23	1663 0724	1	HYDR.LEITUNG VORM.	HYDR.PIPE	CANALISATION HYDR.	TUBERIA HIDRAU.
24	1663 0726	1	HYDR.LEITUNG MONT.	HYDR.PIPE	CANALISATION HYDR.	TUBERIA HIDRAU.
27	0625 8498	4	Rohrschelle 8/8	PIPE CLIP	COLLIER	ABRAZADERA
28	1650 0954	1	Blende 1,5 mm	COVER. PLATE	ECRAN/PARASOLEIL	DIAFRAGMA

D 06

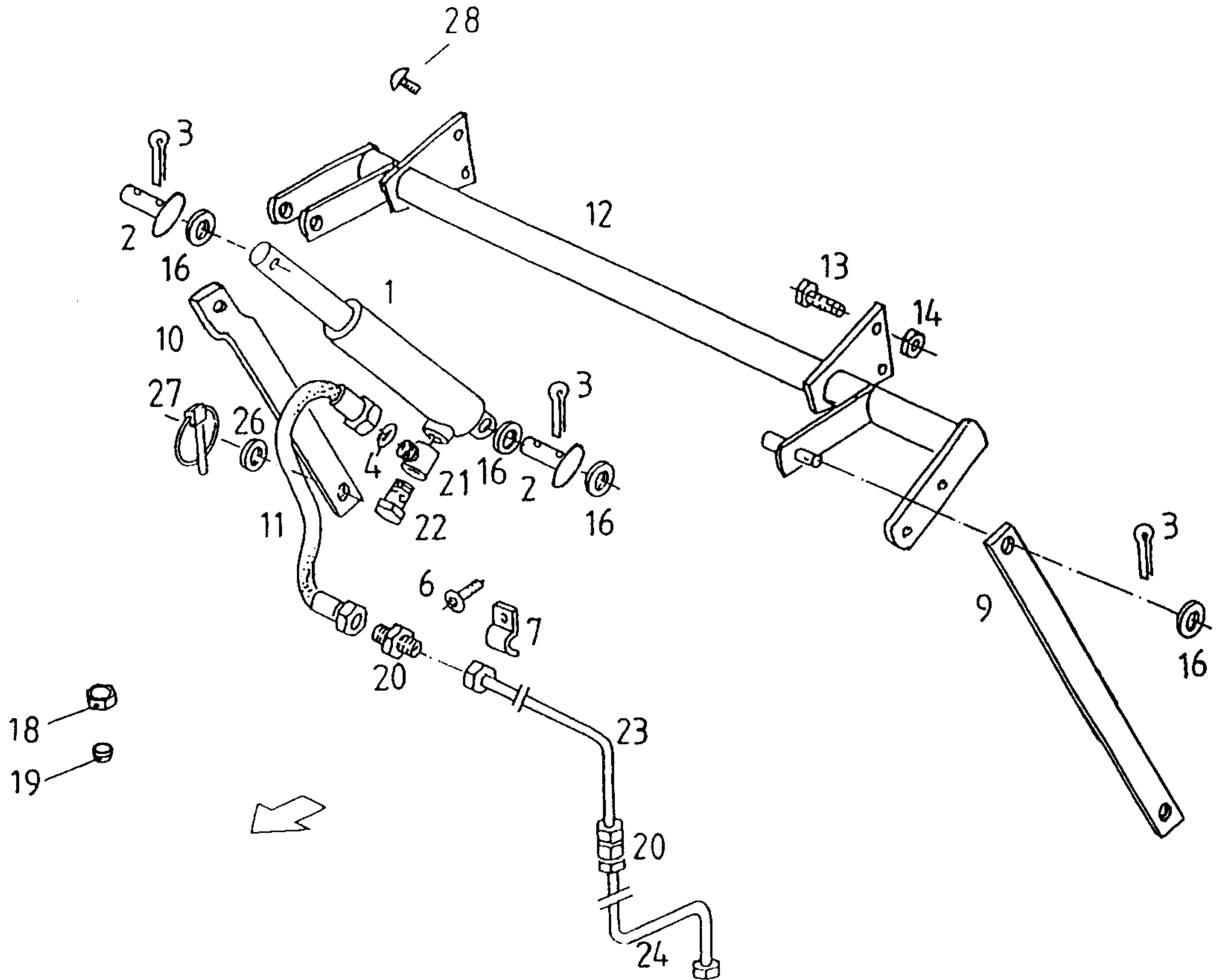

Pos.	Teile-Nr.	Menge	Benennung	Description	Designation	Denominacion	Bildtafel D22 Diagram Diagramme Diagrama Bemerkungen Notes Notes Notas
Pos.	Part. Nr.	Qty.					
Pos.	Piece No.	Qte.					
Pos.	Pieza No.	Cat.					
1	0658 7590	1	HYDROZYLINDER 30/200	HYDROZYLINDER	VERIN HYDR.	CILINDRO HIDR.	
1.1	0628 6217	0	DICHTUNGSSATZ	SEALING SET	JEU DE JOINTS	JUEGO DE JUNTAS	
2	0620 9942	1	BLZ.D1433-16H11X 85X	PIN	AXE	PERNO	
3	0110 6451	5	Splint 4 x 25 A3C	SPLIT PIN	GOUPILLE FENDUE	PASADOR DE ALETAS	
4	0658 1181	1	Blende 1mm	SCREEN	ECRAN	PANTALLA	
5	0657 1018	1	LAGERBOCK GESCHW.	BRACKET	CHEVALET SUPPORT	CABALLETE SOPORTE	
6	0139 7598	3	Sondershr. 5,5x17,5	SELF-TAPPING SCREW	VIS	TORNILLO CHAPA	
7	0621 6397	3	Befestigungsschelle	FIXING CLIP	COLLIER	ABRAZADERA	
9	0657 7584	2	ZUGSTANGE	PULL ROD	TRINGLE DECOMMANDE	TIRANTE	
10	0657 8830	1	BEILAGE	SHIM	CALE	SUPLEMENTO	
11	0657 1331	1	HYDR.SCHLAUCH	HYDR.HOSE	CAN.HYDRAULIQUE	TUBO FLEX.HIDR.	
12	0657 7469	1	DREHROHR GESCHW.	TUBE	TUBE ROTATIF	TUBO	
13	0110 3341	4	Shr. M 12x35 D933	HEX.HEAD SCREW	VIS TETE 6-PANS	TORNILLO HEXAGONAL	
14	0620 9778	4	Sich.Mu. M12 10A3C	LOCK NUT	ECROU DE SECURITE	TUERCA DE SEGURIDAD	
16	0621 4217	5	Scheibe 17,0 A3C	WASHER	RONDELLE	ARANDELA	
18	0112 7346	0	UEBERWURFMUTTER	UNION NUT	ECROU-RACCORD	TUERCA EMPALME	
19	0111 6622	0	Schneidring	CUTTING RING	ANNEAU TRANCHANT	ANILLO CORTANTE	
20	0111 6705	2	Gerader Stutzen	CONNECTING SLEEVE	RACCORD	RACOR	
21	0621 6939	1	Schwenkverschraubung	UNION	RACCORD	RACOR	
22	0117 1004	1	Hohlschraube	HOLLOW BOLT	VIS CREUSE	TORNILLO HUECO	
23	0657 9491	1	HYDR.LEITUNG VORM.	HYDR.PIPE	CANALISATION HYDR.	TUBERIA HIDRAU.	
24	1651 7193	1	HYDR.LEITUNG VORM.	HYDR.PIPE	CANALISATION HYDR.	TUBERIA HIDRAU.	
26	0621 4226	2	Schb. 21,0 D125 A3C	WASHER	RONDELLE	ARANDELA	
27	0112 6332	2	KLST.6 D11023 ST502	DOWEL PIN	BROCHE	PERNO DE FIJACION	
28	0113 9468	1	Bolzen D1444 B16H11	Pin/Bolt	Boulon /axe	Bulon	B D21

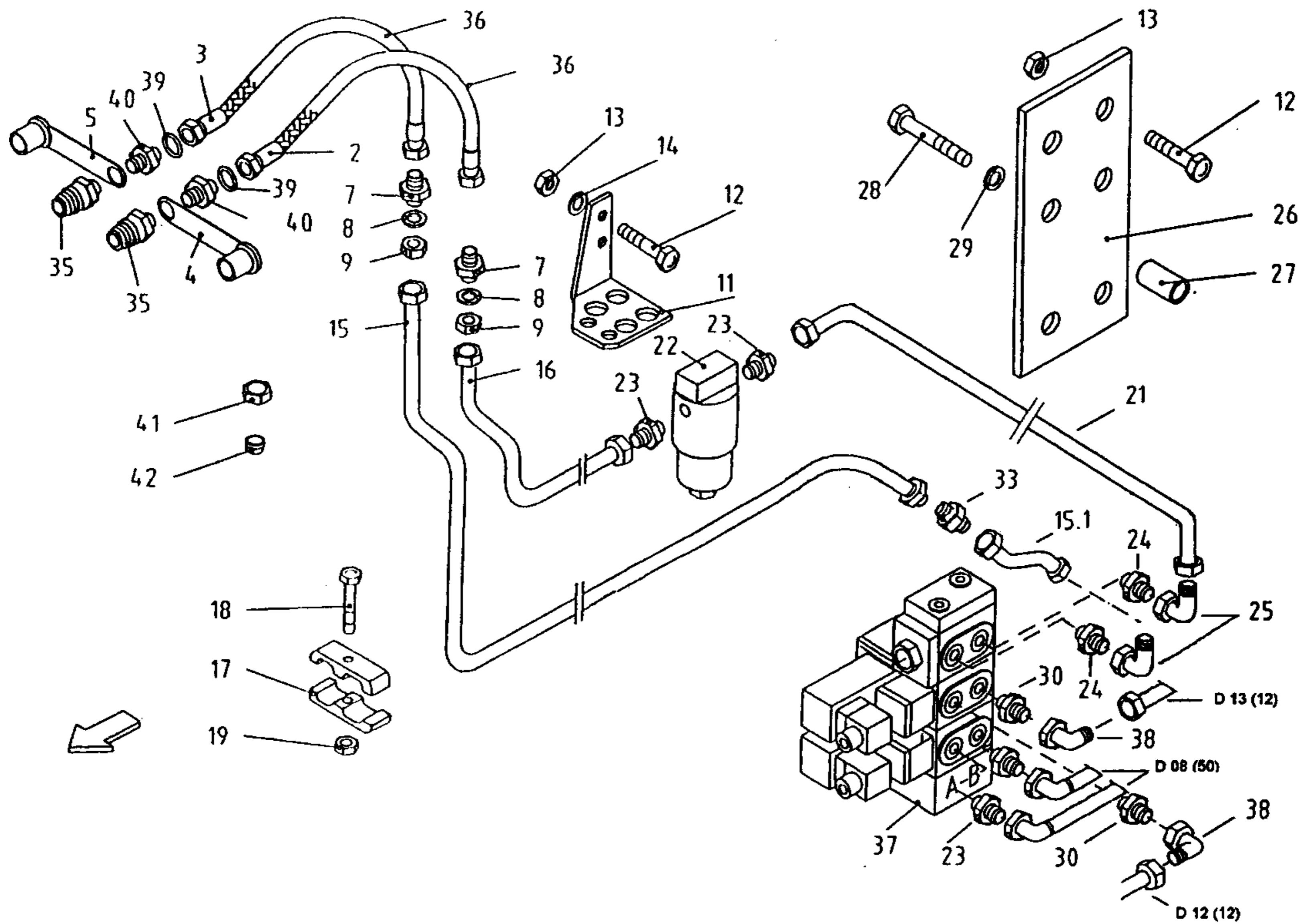

Hydr. Anlage für Kratzboden

Hydr. Scraper floor

Hydr. P. Fond mour

Hidr. P. Fondo rasea

Bildtafel D07

Diagram

Diagramme

Diagrama

Bemerkungen

Notes

Notes

Notas

Pos.	Teile-Nr.	Menge	Benennung	Description	Designation	Denomination
Pos.	Part Nr.	Qty.				
Pos.	Piece No.	Qte.				
Pos.	Pieza No.	Cat.				
2	1651 5428	1	Schrumpfschlauch rot	SHRINK HOSE	FLEX A FRETTER	MANGUERRA CONTRACC
3	1651 3948	1	Schrumpfschl. gelb	SHRINK HOSE	FLEX A FRETTER	MANGUERRA CONTRACC
4	0114 2006	1	Staubkappe rot	DUST CAP	CAPUCH ANTI-POUSS	SOMBREER.CONTR.POLV
5	0657 1341	1	Staubkappe schwarz	DUST GUARD BUSH	MANCH.GUARD POUSS.	MANGUITO GUARDPOLVO
7	0113 3922	2	Stutzen AL15	SOCKET/ADAPTER	TUBULURE/RACCORD	TUBULADURA
8	0621 4307	4	SCHB.23,0x38,0x3,0	WASHER	RONDELLE	DISCO/ARANDELA
9	0113 7633	2	Mutter M 22x1.5	nut	ecrou	tuerca
11	1651 8890	1	Winkelplatte	PLATE	PLAQUE	PLACA
12	0111 2418	4	Shr. M 10x25 88A3C	HEX. HEAD SCREW	VIS TETE 6-PANS	TORN.CAB. HEXAGONAL
13	0620 9768	4	Sich.-Mutter MIO A3C	LOCK NUT	ECROU DE SECURITE	TUERCA DE SEGURIDAD
14	0621 4357	4	Schb.11,0 DIN 126	WASHER	RONDELLE	ARANDELA
15	1663 0607	1	Hydr.Leitung vorm.	GUARD	PROTECTION	PROTECTION
15.1	1663 0638	1	Hydr.Leitung vorm.	GUARD	PROTECTION	PROTECTION
16	1663 0608	1	Hydr.Leitung vorm.	GUARD	PROTECTION	PROTECTION
17	0657 8035	4	Rohrklemme 15/15	CLAMP	COLLIER	ABRAZADERA
18	1663 0497	2	Shr. M 6x35 88A3C	hex.head screw	vis tete 6-pans	torn.cab.hexagonal
19	0111 4357	2	Mu. M6 8A3C	LOCK NUT	ECROU DE SECURITE	TUERCA DE SEGURIDAD
21	1663 0609	1	HYDR.LEITUNG VORM.	hydr. pipe	canalis. hydr.	tuberia hidr.
22	1651 5209	1	Hochdruckfilter	H.P.AIR CLEANER	FILTRE HAUTE PRESS	FILTRO AIRE A/PRES
22.1	1651 4112	0	GLAS-FILTERELEMENT	ELEMENT	CART.FILTRANTE	ELEMENTO FILTRO
23	0111 6685	4	Nippel XGE 15- LM	ERMETO NIPPLE	RACCORD ERMETO	RACOR ERMETO
24	0295 3373	2	Nippel	SCREW-IN NIPPLE	TUBULURE A VIS	TUBULAD.ENROSCADA
25	1661 3433	2	Winkelversch.XEW15-L			
26	1663 0656	1	Grundplatte	BASE PLATE	PLAQUE D'ASSISE	PLACA BASE
27	1663 0461	4	Rohr	PIPE/TUBE	TUBE/TUYAU	TUBO
28	0111 1158	4	Shr.M 8x50 DIN931	BOLT	vis	TORNILLO
29	0110 2799	4	Federring A8 DIN 128	SPRING WASHER	RONDELLE ELASTIQUE	ARANDELA ELASTICA
30	0295 3413	2	Nippel XGE	SCREW-IN NIPPLE	TUBULURE A VIS	TUBULAD.ENROSCADA
33	0111 6710	1	Verbind.Stutzen X6-15			
35	0657 1330	2	Kupplungsstecker	SAFETY PIN	BROCHE	PASADOR
36	1661 0873	2	Hydraulikschlauch	HYDR.HOSE	CAN.HYDRAULIQUE	TUBO FLAX.HIDRAU.
37	1663 0484	1	STUEERBLOCK I/1B	CONTROL BLOCK	BLOC DE COMMANDE	BLOQUE DE MANDO
38	0117 2986	2	Winkelstück X evW	ELBOW	RACCORD COUDE	TUBULADOR ANGULAR
39	0621 4809	2	Rdr. 18,0x2,5	SEAL RING	JOINT	JUNTA
40	1661 0791	2	EINSCHRAUBSTUTZEN	SCREW-IN NIPPLE	TUBULURE A VIS	TUBULAD.ENROSCADA
41	0111 6653	0	UEBMU.H3105-CL15-ST	union nut	ecrou-raccord	tuerca empalme
42	0111 6626	0	SCHNRG.L15 D3861 ST	CUTTING PING	ANNEAU TRANCHANT	ANILLO CORTANTE

D 08

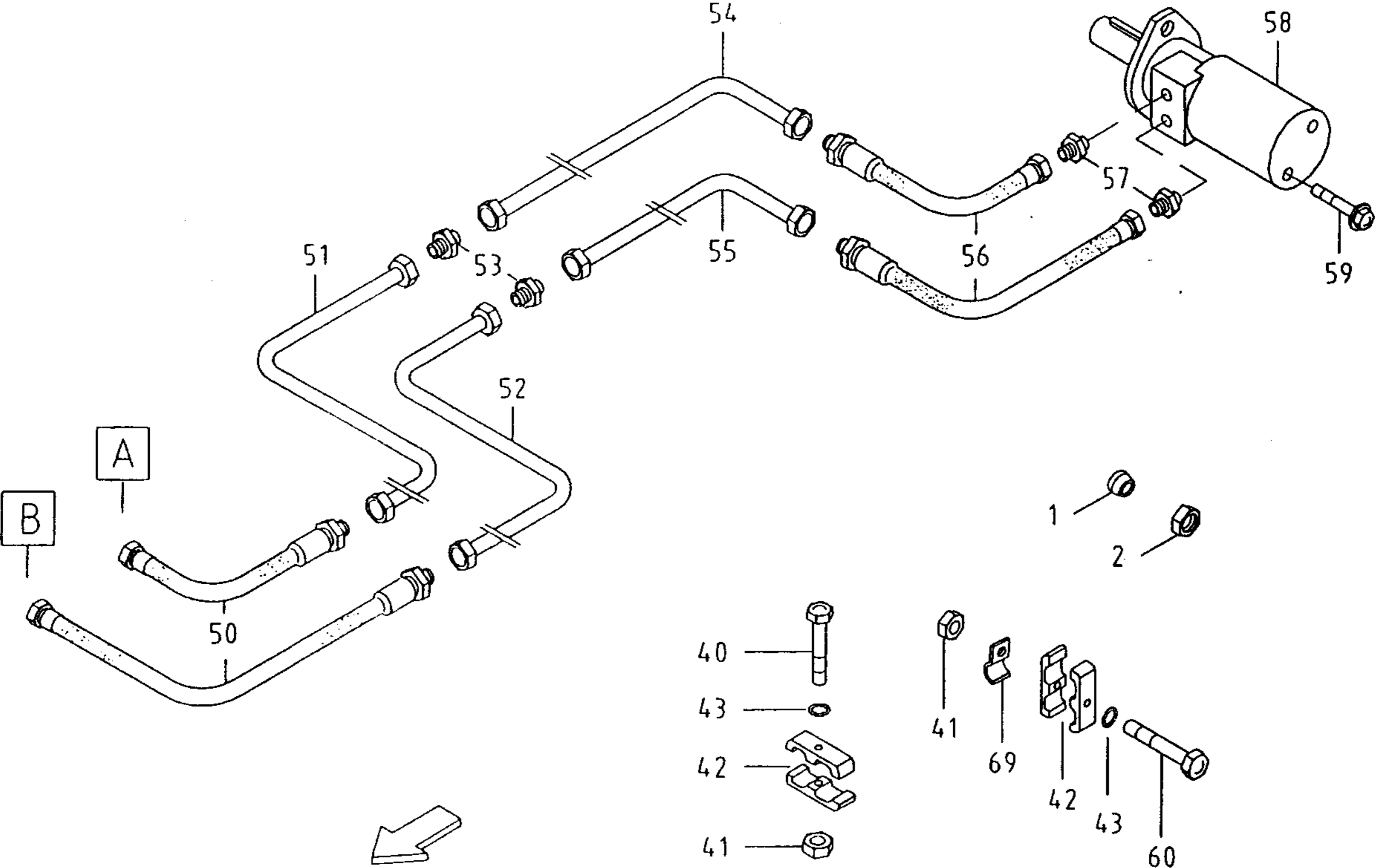

Pos.	Teile-Nr.	Menge	Benennung	Description	Designation	Denominacion
Pos.	Part.Nr.	Qty.				
Pos.	Piece No.	Qte.				
Pos.	Pieza No.	Cat.				
			Hydr. Für Kratzboden Motor	hydr.scraprer floor motor	Hydr.p.fond. mouv. moteur	Hidr.p.fondo rasca. motor
1	0111 6626	0	SCHNRG.L15 D3861 ST	CUTTING RING	ANNEAU TRANCHANT	ANILLO CORTANTE
2	0111 6653	0	UEBMU.H3105-CL15-ST	union nut	ecrou-raccord	tuerca empalme
40	1663 0497	8	Shr.M 6x35 88A3C	hex.head screw	vis tete 6-pans	torn.cab.hexagonal
41	0111 4357	13	Mu. M6 8A3C	LOCK NUT	ECROU DE SECURITE	TUERCA DE SEGURIDAD
42	0657 8035	26	Rohrklemme 15/15	CLAMP	COLLIER	ABRAZADERA
43	0110 7095	13	Scheibe D125 A3C	WASHER	RONDELLE	ARANDELA
50	1661 3310	2	Hydr. Schlauch	hydr. hose	flexible tube hydr.	flexible tubo hidr.
51	1663 0624	1	Hydi. L ^e itung vorm.	hydr.pipe	canalisation hydr.	tuberia hidrau.
52	1663 0625		Hydr. Leitung vorm.	hydr.pipe	canalisation hydr.	tuberia hidrau.
53	0111 6710	2	Verb. StutzenXG15-L	Connecting sleeve	RACCORD	RACOR
54	1663 0626	1	Hydr. Leitung vorm.	hydr.pipe	canalisation hydr.	tuberia hidrau.
55	1663 0627	1	Hydr. Leitung vorm.	hydr.pipe	canalisation h dr .	tuberia hidrau.
56	1661 3309	2	Hydr. Schlauch	hydr. hose	flexible tubo dr.	flexible tubo hidr.
57	0621 6836	2	NIPPEL XGE 15- LR ED	SREW-IN UNI ON	RACCORD A VISSE	UNION ROSCA EXTER.
58	1661 1052	1	HYDR.MOTOR MF160	HYDRAULIC MOTOR	MOTEUR HYDRAULIQUE	MOTOR HIDRAULICO
59	0621 4156	2	RIPP-SCHRAUBE	SCREW	VIS	TORNILLO
60	0111 1079	5	SHR.M6x50 8.8A3C	HEX. HEAD SCREW	VIS TETE 6-PANS	TORN. CAB. HEXAGONAL
69	0621 6397	5	Befestigungsschelle	Fixing clip	collier	abrazadera

Bildtafel D 08

Diagram

Diagramme

Diagrama

Bemerkungen

Notes

Notes

Notas

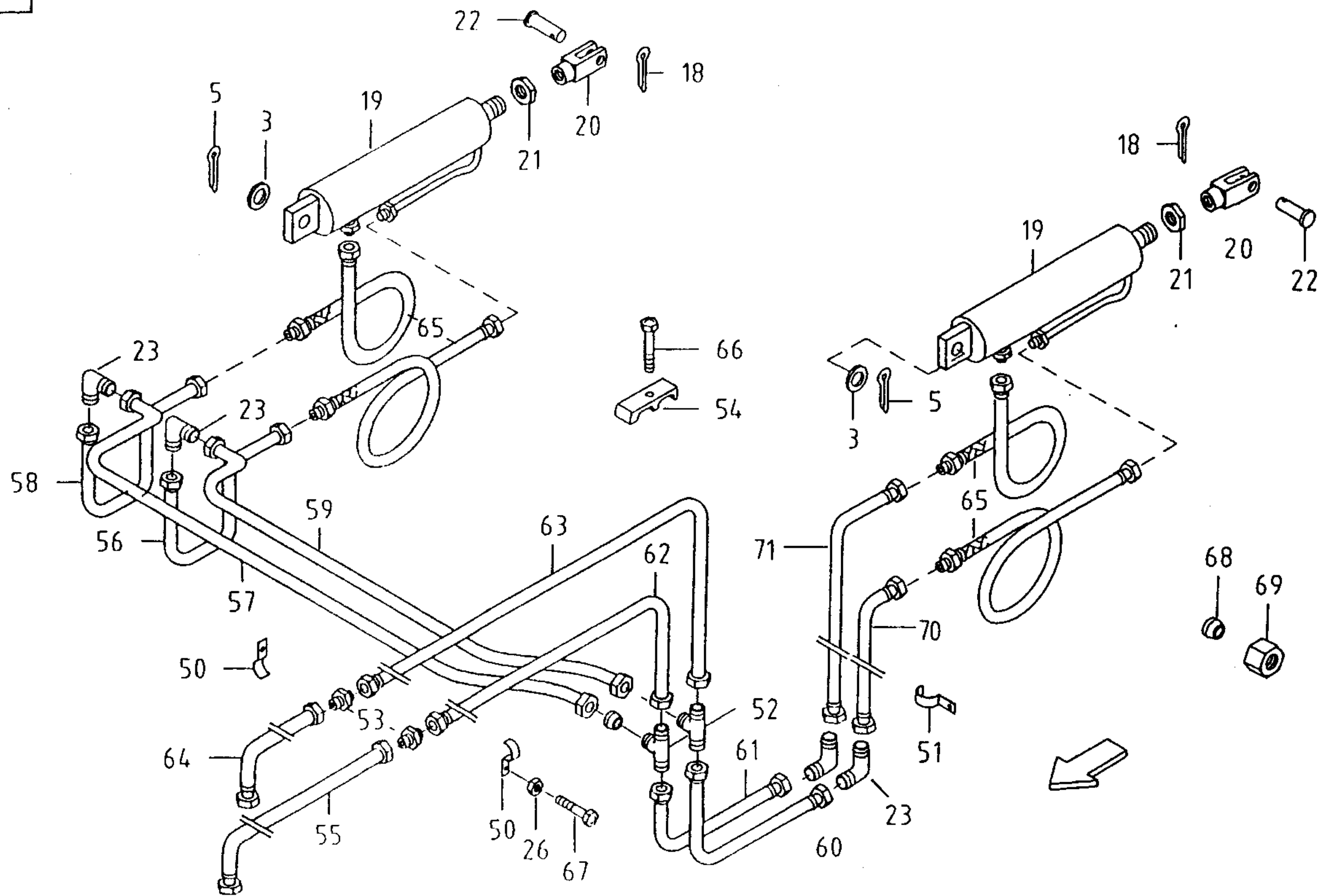

Bildtafel D09

Diagram

Diagramme

Diagrama

Bemerkungen

Notes

Notes

Notas

Hydr. Anlage für Rückwand hydraulic for rear gate hydraulique pour porte arriere hidraulico_para puerta atras

Pos.	Teile-Nr.	Menge	Benennung	Description	Designation	Denominacion
Pos.	Part.Nr.	Qty.				
Pos.	Piece No.	Qte.				
Pos.	PiezaNo.	Cat.				
5	0113 2647	2	Splint 6,3x40	SPLIT PIN	GOUPILLE FENDUE	PASADOR ALETAS
3	0112 8377	2	SCHB.26,0 DIN 126	WASHER/DISC/PLATE	RONDELLE/DISQUE	DISCO/ARANDELA
18	0112 2072	2	Splint 5x32 D94 A3C	SPLIT PIN	GOUPILLE FENDUE	PASADOR ALETAS
19	1663 0455	2	HYDR.ZYL.DW.	Hydraulic cylinder	CYLINDRE HYDRAUL	CILINDRO HYDRAULIC
19.1	1663 0456	0	DICHTUNGSSATZ	SEALING SET	JEU DE JOINTS	LOTE JUNTAS
20	1661 2329	2	GABELK.G20x40	CLEVIS	CHAPE	CABEZA HORQUILLA
21	0113 8933	2	Mu.BM20x1,5	HEXNUT	ECROU 6-PANS	TUERCA-HEXAGONAL
22	0621 0040	2	BLZ.D1434-20H11	PIN	AXE	PERO
23	0111 6731	4	Verb.Wi.Stutz.D3905	SOCKET/ADAP	TUBULURE/RACCORD	TUBULADURA
26	0111 4357	9	Mu. 116 8A3C	LOCK NUT	ECROU DE SECURITE	Tuerca de seguridad
50	0621 6397	6	Befestigungsschelle	FIXING CLIP	COLLIER	ABRAZADERA
51	0621 6396	12	Kabelschelle 8x15x9	HOSE CLIP	COLLIER DE SERRAGE	ABRAZADERA
52	0111 6740	2	T-Stutzen XT 8-L	nozzle	manchon	manguito
53	0111 6705	2	Verb.Stutzen XG 8-L	Connecting sleeve	RACCORD	RACOR
54	1663 0453	3	Rohrschelle doppelt	PIPE CLIP	COLLIER	ABRAZADERA
55	1663 0516	1	Hydr.Leitung vorm.	hydr.pipe	canalisation hydr.	tuberia hidrau.
56	1663 0651	1	Hydr.Leitung vorm.	hydr.pipe	canalisation hydr.	tuberia hidrau.
57	1663 0526	1	Hydr.Leitung vorm.	hydr.pipe	canalisation hydr.	tuberia hidrau.
58	1663 0644	1	Hydr.Leitung vorm.	hydr.pipe	canalisation hydr.	tuberia hidrau.
59	1663 0528	1	Hydr.Leitung vorm.	hydr.pipe	canalisation hydr.	tuberia hidrau.
60	1663 0677	1	Hydr.Leitung vorm.	hydr.pipe	canalisation hydr.	tuberia hidrau.
61	1663 0673	1	Hydr.Leitung vorm.	hydr.pipe	canalisation hydr.	tuberia hidrau.
62	1663 0521	1	Hydr.Leitung vorm.	hydr.pipe	canalisation hydr.	tuberia hidrau.
63	1663 0523	1	Hydr.Leitung vorm.	hydr.pipe	canalisation hydr.	tuberia hidrau.
64	1663 0518	2	Hydr.Leitung vorm.	hydr.pipe	canalisation hydr.	tuberia hidrau.
65	1661 3311	4	Hydr.Schlauch 600	hydr.ose	tuyau hydr.	Tubo flax.hidr.
66	1663 0463	3	Zyl. Shr.M6x25 8.8	Hex.haed screw	VIS TETE 6-PANS	TORN.CAB.Hexagonal
67	0114 2806	6	Fird.Shr.M6x25	TRUSS-HEAD SCREW	VIS TETE BOMBEE	TORN.CAB.SEMIRED.
68	0111 6622	0	Schrg.L,8 ST	CUTTING RING	ANNEAU TRANCHANT	ANILLO CORTANTE
69	0112 7346	0	Übw.Mu.H3105-CL	UNION NUT	ECROU-RACCORD	TUERCA EMPALME
70	1663 0679	1	Hydr.Leitung vo'm.	hydr.pipe	canalisation hydr.	tuberia hidrau.
71	1663 0675	1	Hydr.Leitung vorm.	hydr.pipe	canalisation hydr.	tuberia hidrau.

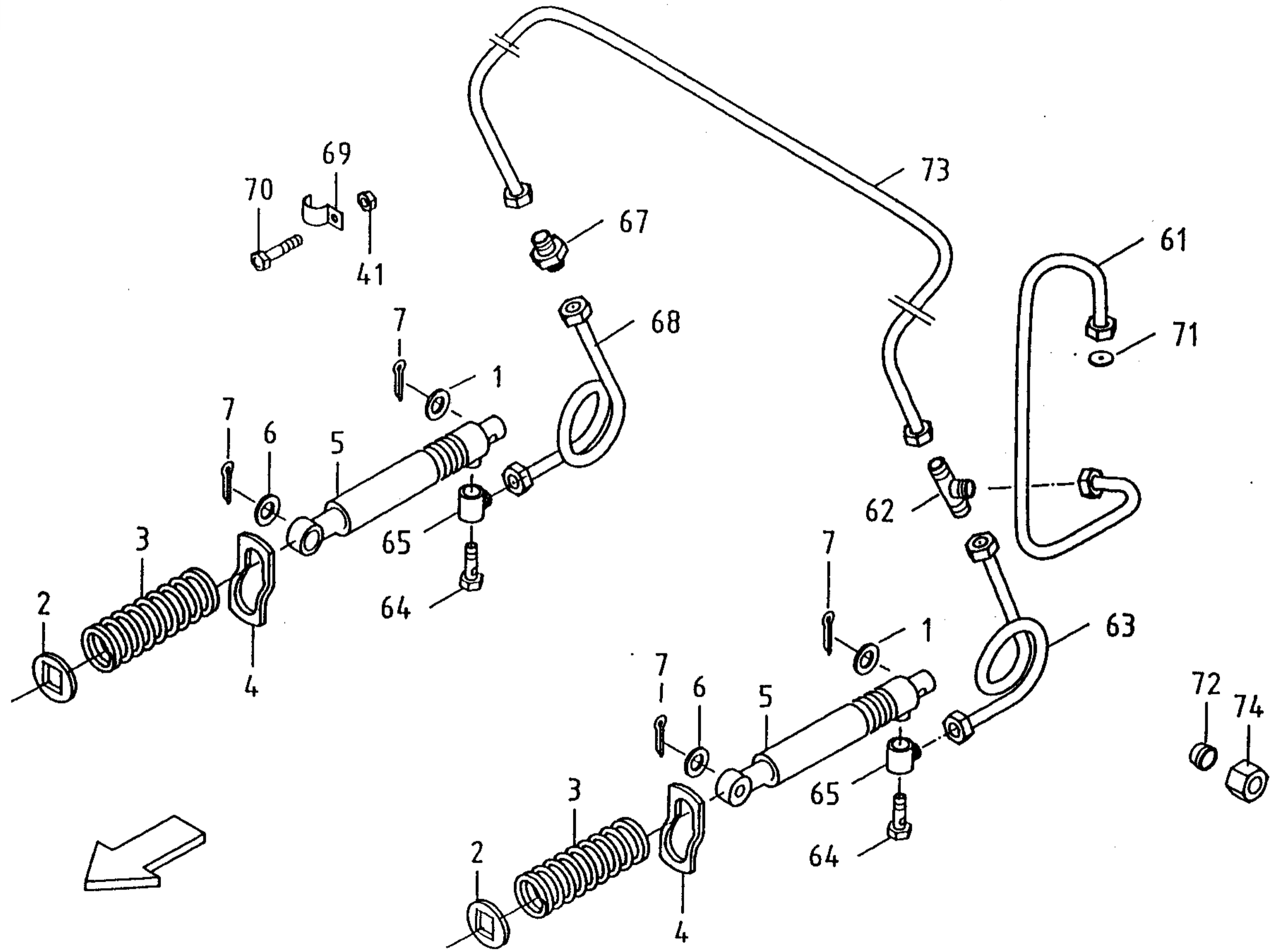

Bildtafel D10

Diagram

Diagramme

Diagrama

Bemerkungen

Notes

Notes

Notes

Hydr. Anlage für Pick-Up hydraulic for pick-up hydraulique pour pick-up hidraulico por pick.up

Pos.	Part.Nr.	Qty.	Benennung	Description	Designation	Denominacion
Pos.	Piece No.	Qte.				
Pos.	Pieza No.	Cat.				
1	0621 4449	2	SCHB.15,0 DIN7349	WASHER/DISC/PLATE	RONDELLE/DISQUE	DISCO/ARANDELA
2	1651 9184	2	Scheibe	WASHER/DISC/PLATE	RONDELLE/DISQUE	DISCO/ARANDELA
3	0621 5425	2	Druckfeder	COMPRESSION SPRING	RESSORT DE Pression	MUELLE DE PRESION
4	0657 6503	2	Schiebelasche	CLIP	ECLISSE	ECLISA
5	1651 4629	2	Zylinder (Plunger)	HYDR. RAM	CYLINDRE	CILINDRO
5.1	1650 4079	0	Dichtsatz (Bueter)	SEALING SET	JEU DE JOINTS	LOTE JUNTAS
6	1660 4743	2	Stützscheib.16-22-1,5	Washer	Rondelle	Arandela
7	0110 6451	4	Splint 4x25 A3C	SPLIT PIN	GOUPILLE FENDUE	PASADOR DE ALETAS
41	0111 4357	6	Mu. M6 8A3C	LOCK NUT	ECROU DE SECURITE	TUERCA DE SEGURIDAD
61	1663 0633	1	HYDR.LEITUNG VORM.	HYDR.PIPE	CANALISATION HYDR.	TUBERIA HIDRAU.
62	0111 6740	1	T-Stutzen	nozzle	manchon	manguito
63	0657 7864	1	HYDR.LEITUNG VORM.	HYDR.PIPE	CANALISATION HYDR.	TUBERIA HIDRAU.
64	0117 1004	2	Hohlschraube	HOLLOW BOLT	VIS CREUSE	TORNILLO HUECO
65	0621 6939	2	Schwenkverschraubung	UNION	RACCORD	RACOR
68	1661 3306	1	Hydr. Leitung vorm	hydr.hose	canalis.hydr.	tuberia hidr.
69	0621 6397	6	Befestigungsschelle	F XING CLIP	COLLIER	ABRAZADERA
70	0111 2264	6	Shr. M 6x.20 DIN 933	HEX. HEAD SCREW	VIS TETE 6-PANS	TORN.CAB. HEXAGONAL
71	0658 1181	1	Blende 1mm	SCREEN	ECRAN	PANTALLA
72	0111 6622	0	Schneidring	CUTTING RING	ANNEAU TRANCHANT	ANILLO CORTANTE
73	1661 3325	1	Hydr. Leitung vorm.	hydr.hose	canalis.hydr.	tuberia hidr.
74	0112 7346	0	Überwurfmutter	UNION NUT	ECROU-RACCORD	TUERCA EMPALME

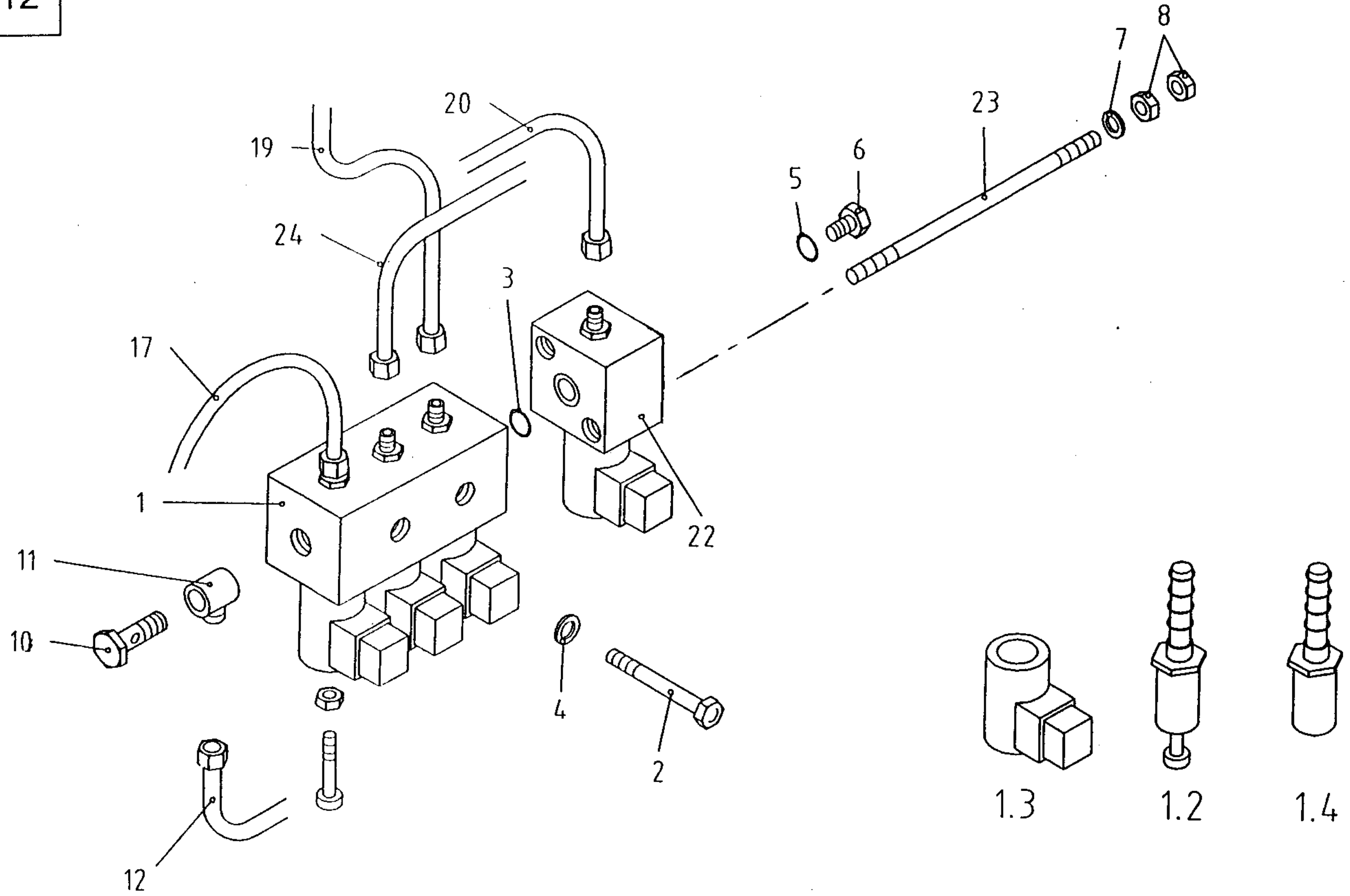

Bildtafel D12Diagram
Diagramme
Diagrama
BemerkungenNotes
Notes
Notas

Pos.	Teile-Nr.	Menge	Benennung	Description	Designation	Denomination
			Hydr. Steuerung	hydr.steering	commande hydr	mando hidr.
Pos.	Part.Nr.	Qty.				
Pos.	Piece No.	Qte.				
Pos.	Pieza No.	Cat.				
1	1651 6558	1	Ventilblock 3-fach	VALVE BLOCK	BLOC DE SOUPAPE	BLOC DE VALVULA
1.2	1651 5024	0	Ventilpatrone mit	VALVE	SOUPAPE	VALVULA
1.3	1651 5023	0	Spule 12V ZU1249/47	COIL	BOBINE	BOBINA
1.4	1651 5022	0	Ventilpatrone	VALVE	SOUPAPE/ROBINET	VALVULA
2	0111 1168	2	SHR.M 8X60 D931	HEX. HEAD SCREW	VIS TETE 6-PANS	TORN. CAB.HEXAGONAL
3	0116 9581	3	RDR. 14,0x2,0	O-RING	BAGUE-0	ANILLO-0
4	0110 7163	2	Schb. 9x17x1,6 A3C	WASHER	RONDELLE	ARANDELA
5	0111 8675	1	D-Ring	SEAL RING	JOINT	JUNTA
6	0114 3104	1	Verschlußschraube	SCREW PLUG	BOUCHON FILETE	TAPON ROSCADO
7	0114 3103	2	Scheibe 8,0 DIN 1441	WASHER/DISC/PLATE	RONDELLE/DISQUE	DISCO/ARANDELA
8	0111 2824	4	Mu. M 8 8A3C	HEX. NUT	ECROU 6-PANS	TUERCA HEXAGONAL
10	0117 1004	1	Hohlschraube X HS	HOLLOW BOLT	VIS CREUSE	TORNILLO HUECO
11	0621 6939	1	Schwenkverschraubung	UNION	RACCORD	RACOR
12	1663 0613	1	Hydr.Leitung vorm.	HYDR.PIPE	CANALISATION HYDR.	TUBERIA HIDRAU.
16.1	0656 8560	1	HYDRAULIKSCHLAUCH	HYDR. HOSE	CAN. HYDRAULIQUE	TUBO FLEX. HIDR.
17	1663 0633	1	HYDR.LEITUNG VORM.	HYDR.PIPE	CANALISATION HYDR.	TUBERIA HIDRAU.
19	1663 0632	1	HYDR.LEITUNG VORM.	HYDR.PIPE	CANALISATION HYDR.	TUBERIA HIDRAU.
20	1663 0724	1	HYDR.LEITUNG VORM.	HYDR.PIPE	CANALISATION HYDR.	TUBERIA HIDRAU.
22	1651 1249	1	Ventilblock 1-fach	VALVE BLOCK	BLOC DE SOUPAPE	BLOC DE VALVULA
23	1663 0486	2	GEW.BLZ.BM8X170	THREADED PIN	BOULON FILETE	BULON ROSCADO
24	1663 0516	1	HYDR.LEITUNG VORM.	HYDR.PIPE	CANALISATION HYDR.	TUBERIA HIDRAU.

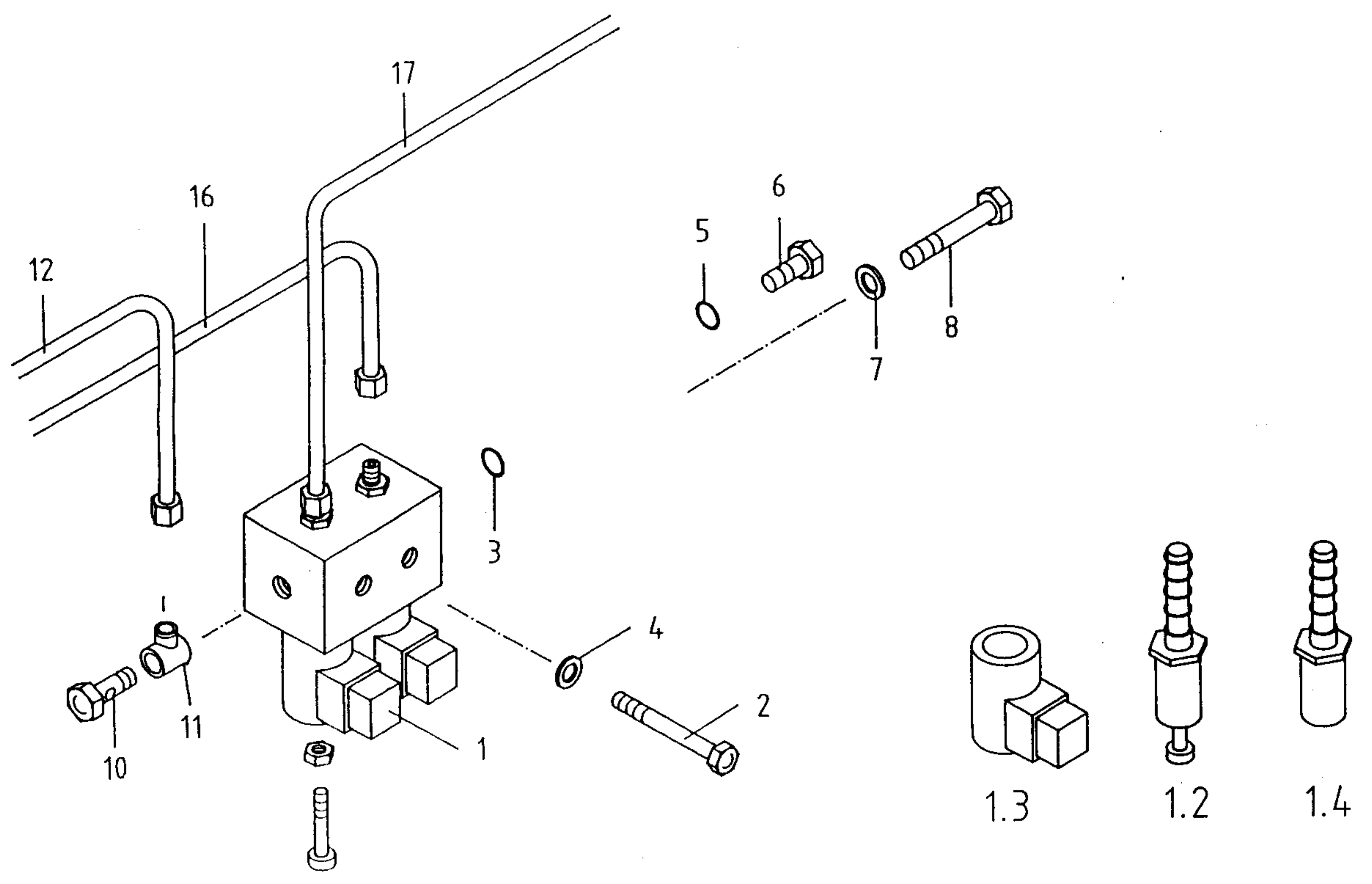

Hydr. Anlage Grundumfang

hydr. steering

commande hydr.

mando hidr.

Bildtafel D13

Diagram

Diagramme

Diagrama

Bemerkungen

Notes

Notes

Notas

Pos.	Teile-Nr.	Menge	Benennung	Description	Designation	Denominacion
Pos.	Part.Nr.	Qty.				
Pos.	Piece No.	Qte.				
Pos.	Pieza No.	Cat.				
1	1651 4411	1	Ventilblock 2-fach	VALVE BLOCK	BLOC DE SOUPAPE	BLOC DE VALVULA
1.2	1651 5024	0	Ventilpatrone mit	VALVE	SOUPAPE	VALVULA
1.3	1651 5023	0	Spule 12V ZU1249/47	COIL	BOBINE	BOBINA
1.4	1651 5022	0	VENT.EINSCHR.PATRONE	VALVE	SOUPAPE/ROBINET	VALVULA
2	0111 1168	2	SHR.M 8X50 D931	HEX. HEAD SCREW	VIS TETE 6-PANS	TORN. CAB. HEX.
3	0116 9581	1	RDR. 14,0x2,0	O-RING	BAGUE-0	ANILLO-0
4	0110 7163	2	Scab. 9x17x1,6 A3C	WASHER	RONDELLE	ARANDELA
5	0111 8675	1	D-Ping	SEAL RING	JOINT	JUNTA
6	0114 3104	1	Verschußschraube	SCREW PLUG	BOUCHON FILETE	TAPON ROSCADO
7	0114 3103	2	Scheibe 8,0 DIN 1441	WASHER/DISC/PLATE	RONDELLE/DISQUE	DISCO/ARANDELA
8	0112 2397	2	SHR.M 8X55 D931	HEX.BOLT	VIS 6 PANS	TORNILLO HEXAGONAL
10	0117 1004	1	Hohlschraube X HS	HOLLOW BOLT	VIS CREUSE	TORNILLO HUECO
11	0621 6939	1	Schwenkverschraubung	UNION	RACCORD	RACOR
12	1663 0612	1	HYDR.LEITUNG MONT.	HYDR.PIPE	CANALISATION HYDR.	TUBERIA HIDRAU.
13	0111 6622	0	Schrg.L8 DIN 3861-ST	CUTTING RING	ANNEAU TRANCHANT	ANILLO CORTANTE
14	0112 7346	0	Übw.Mu.H310S-CL 8-St	UNION NUT	ECROU-RACCORD	TUERCA EMPALME
16	1663 0726	1	HYDR.LEITUNG MONT.	HYDR.PIPE	CANALISATION HYDR.	TUBERIA HIDRAU.
17	1663 0518	1	HYDR. LE ITUNG MONT.	HYDR.PIPE	CANALISATION H DR.	TUBERIA HIDRAU.
18	1651 1249	1	Ventilblock 1-fach	VALVE BLOCK	BLOC DE SOUPAPE	BLOCDE VALVULA

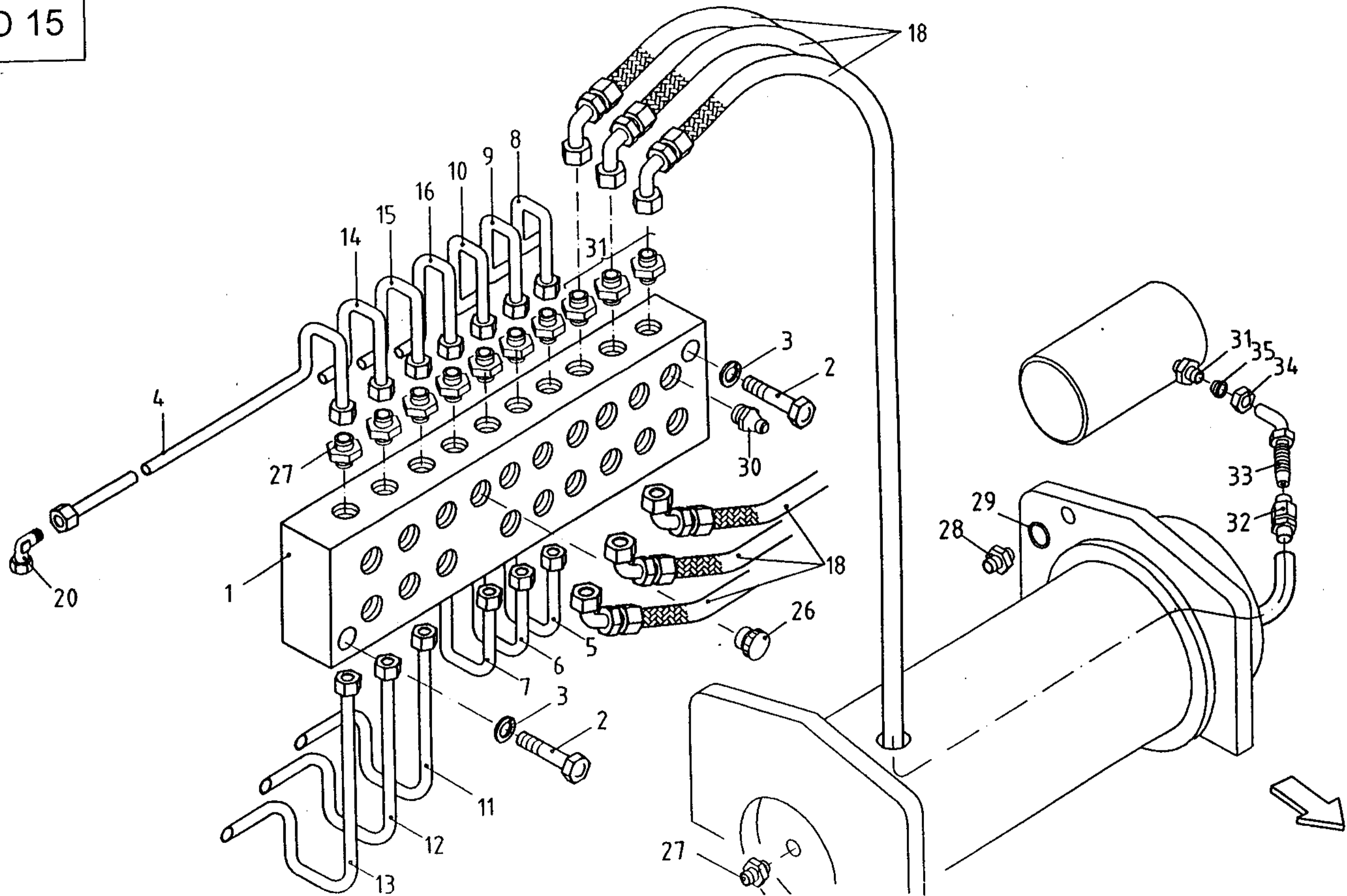

Zentralschmierung
Trommel 6 Rechen

lube system
drum with 6 rakes

graissage central.
tamb.avec 6 rateaux

lubricacion central
tramb.p.6 rastrillos

Bildtafel D15

Diagram

Diagramme

Diagrama

Pos.	Teile-Nr.	Menge	Benennung	Description	Designation	Denominacion	Bemerkungen
Pos.	Part.Nr.	Qty.					Notes
Pos.	Piece No.	Qte.					Notes
Pos.	Pieza No.	Cat.					Notas
1	1663 0171	1	Schmierleiste	strip	listeau/moulure	liston	
2	0112 2389	2	Shr M6x35 88 A3C	hex head screw	vis tete 6-pans	torn cab. hexagonl	
3	0110 2797	2	Fedrg. A 6 DIN 128	SPRING WASHER	RONDELLE ÉLASTIQUE	ARANDELA ELÁSTICA	
4	1663 0172	1	Schmierleitu.1 mont.	lube tube	tuyau graissage	tubo lubricacion	
5	1663 0174	1	Schmierleitu.2 mont.	lube tube	tuyau graissage	tubo lubricacion	
6	1663 0176	1	Schmierleitu.3 mont.	lube tube	tuyau graissage	tubo lubricacion	
7	1663 0178	1	Schmierleitu.4 mont.	lube tube	tuyau graissage	tubo lubricacion	
8	1663 0180	1	Schmierleitu.5 mont.	lube tube	tuyau graissage	tubo lubricacion	
9	1663 0182	1	Schmierleitu.6 mont.	lube tube	tuyau graissage	tubo lubricacion	
10	1663 0184	1	Schmierleitu.7 mont.	lube tube	tuyau graissage	tubo lubricacion	
11	1663 0186	1	Schmierleitu.8 mont.	lube tube	tuyau graissage	tubo lubricacion	
12	1663 0188	1	Schmierleitu.9 mont.	lube tube	tuyau graissage	tubo lubricacion	
13	1663 0190	1	Schmierleitu.10mont.	lube tube	tuyau graissage	tubo lubricacion	
14	1663 0192	1	Schmierleitu.11mont.	lube tube	tuyau graissage	tubo lubricacion	
15	1663 0194	1	Schmierleitu.12mont.	lube tube	tuyau graissage	tubo lubricacion	
16	1663 0196	1	Schmierleitu.13mont.	lube tube	tuyau graissage	tubo lubricacion	
18	1663 0200	6	Schmierschlauch 2 mont	lube tube	Flexible graissage	Manguera lubrcation	
20	0621 6854	1	W-Stutzen 2 mont.	ANGULAR UNION	RACCORD ANGULAIRE	RACOR ANGUIAR	
26	0621 6527	0	KAPSTO M 8x1	PROTECTING PLUG	BOUCHON DÉ	TAPON DÉ PROTECTION	
27	0621 6815	19	Nippel	NIPPLE	RACCORD	RACOR	
28	0139 7760	6	Nippel	SOCKET/ADAPTER	TUBULURE/RACCORD	TUBULADURA	
29	0116 3589	6	RDR. 6,0X2,0	O-RING	BAGUÉ 0	ANILLO	
30	0112 0693	19	Schmiernippel AM HI	GREASE NIPPLE	GRAISSEUR A PRESSION	ENGRASADOR	
31	0139 7933	12	Nippel	SOCKET/ADAPTER	TUBULURE/RACCORD	TUBULADURA	
32	1651 6717	6	Schraubhülse	SCREW SLEEVE	DOUILLE A VIS	CASQUILLO ROSCADO	
33	1651 8135	6	Rohrstutzen gebogen	PIPÉ SOCKET	TUBULURE	TUBULADURA	
34	0110 0982	6	Überwurfmutter	UNION NUT	ÉCROU DÉ RACCORD	TUERCA UNION	
35	0129 2484	6	Schneidring	SEALING	JOINT	JUNTA	

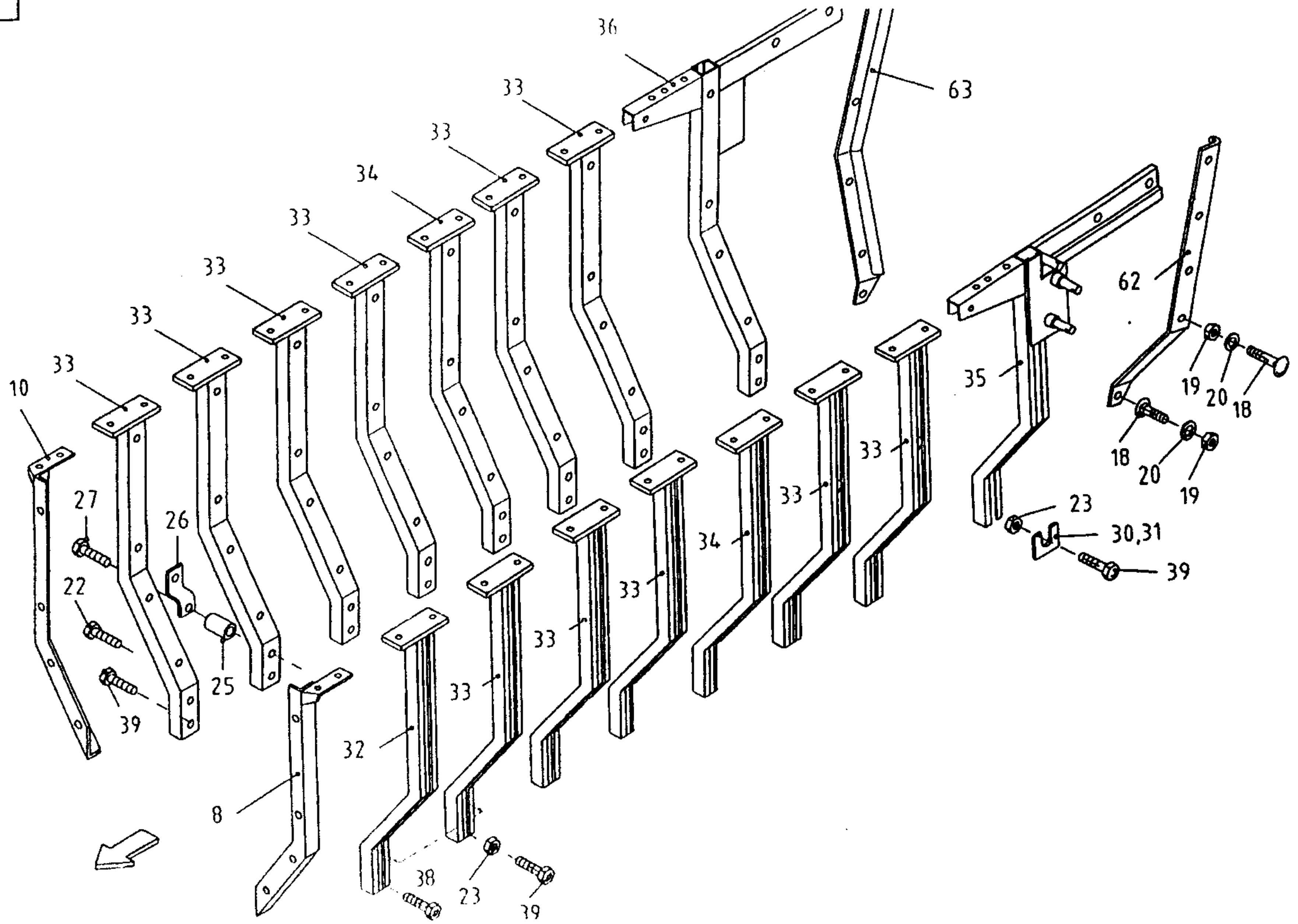

Bildtafel E01

Diagram

Diagramme

Diagrama

Bemerkungen

Notes

Notes

Notas

Grüngut Aufbau Stützen

Green fodder super-
structure supportsSuperst.p.furr. ver.
supports

Supers.p.ver soportes

Pos.	Teile-Nr.	Menge	Benennung	Description	Designation	Denominacion
Pos.	Part.Nr.	Qty.				
Pos.	Piece No.	Qte.				
Pos.	Pieza No.	Cat.				
8	1663 0330	1	Eckprofil li. gsw.	CORNER STIFFENER	PROFIL ANGULULAIRE	PERFIL ESQUINA
10	1663 0331	1	Eckprofil re. gsw.	CORNER PROFILE	PROFIL	PERFILADO
18	0620 7534	14	Shr.M8x20 8.8A3C	SAUCER HEAD SCREW	VIS A TETE BOMBEE	TORN. CAB. BOMBEADA
19	0110 4944	14	Sich.Mu.M8 8A3C	LOCK NUT	ECROU DE SECURITE	TUERCA DE SEGURIDAD
20	0621 4192	14	Scheibe 8,4x25x3 A3C	WASHER	RONDELLE	ARANDELA
22	0117 7453	1	SHR.H2091 DIN 931	HEX.BOLT	VIS 6 PANS	TORNILLO HEXAGONAL
23	0620 9769	30	Mu.M 12 8A3C	Lack nut	Ecrou de securite	Tuerca de seguridad
24	0621 4207	9	Scheibe 13x24x2,5A3C	WASHER	RONDELLE	ARANDELA
25	0658 1494	7	Abstandrohr	SPACER TUBE	ENTRETOISE	TUBO DISTANCIADOR
25.1	1661 3370	1	Abstandrohr	SPACER TUBE	ENTRETOISE	TUBO DISTANCIADOR
26	1651 1577	8	Lasche	CONNECTING PLATE	ECLISSE	ECLISA
27	0111 1540	7	Schr.M 12x85 D931	hex.bolt	vis tete 6-pans	tornillo hexagonal
30	0657 7563	2	UNTERLEGPLATTE	SHIM	CALE	SUPLEMENTO
31	0657 7562	2	UNTERLEGPLATTE	SHIM	CALE	SUPLEMENTO
32	1663 0432	1	Seitenwandstütze	v.1.SUPPORT	SUPPORT	SOPORT
33	1663 0303	11	Seitenwandstütze	SUPPORT	SUPPORT	SOPORT
34	1663 0434	2	Seitenwandstütze kz.	SUPPORT	SUPPORT	SOPORT
35	1663 0307	1	Seitenwandstütze h.1.	SUPPORT	SUPPORT	SOPORT
36	1663 0308	1	Seitenwandstütze	h.r.SUPPORT	SUPPORT	SOPORT
38	0627 7504	1	Shr.H2091 DIN 933	HEX. HEAD SCREW	VIS TETE 6-PANS	TORNILLO
39	0111 2538	20	Shr.M12x35 DIN 933	hex.head screw	VIS TETE 6-PANS	torn.cab.hexagonal
39.1	0111 2554	3	Shr.M12x45 DIN 933	hex.head screw	VIS TETE 6-PANS	torn.cab.hexagonal
62	1661 2386	1	Randleiste li.	CROSS BAR	BARRETTE	LISTON
63	1661 2387	1	Randleiste re.	CROSS BAR.	BARRETTE	LISTON

E 02

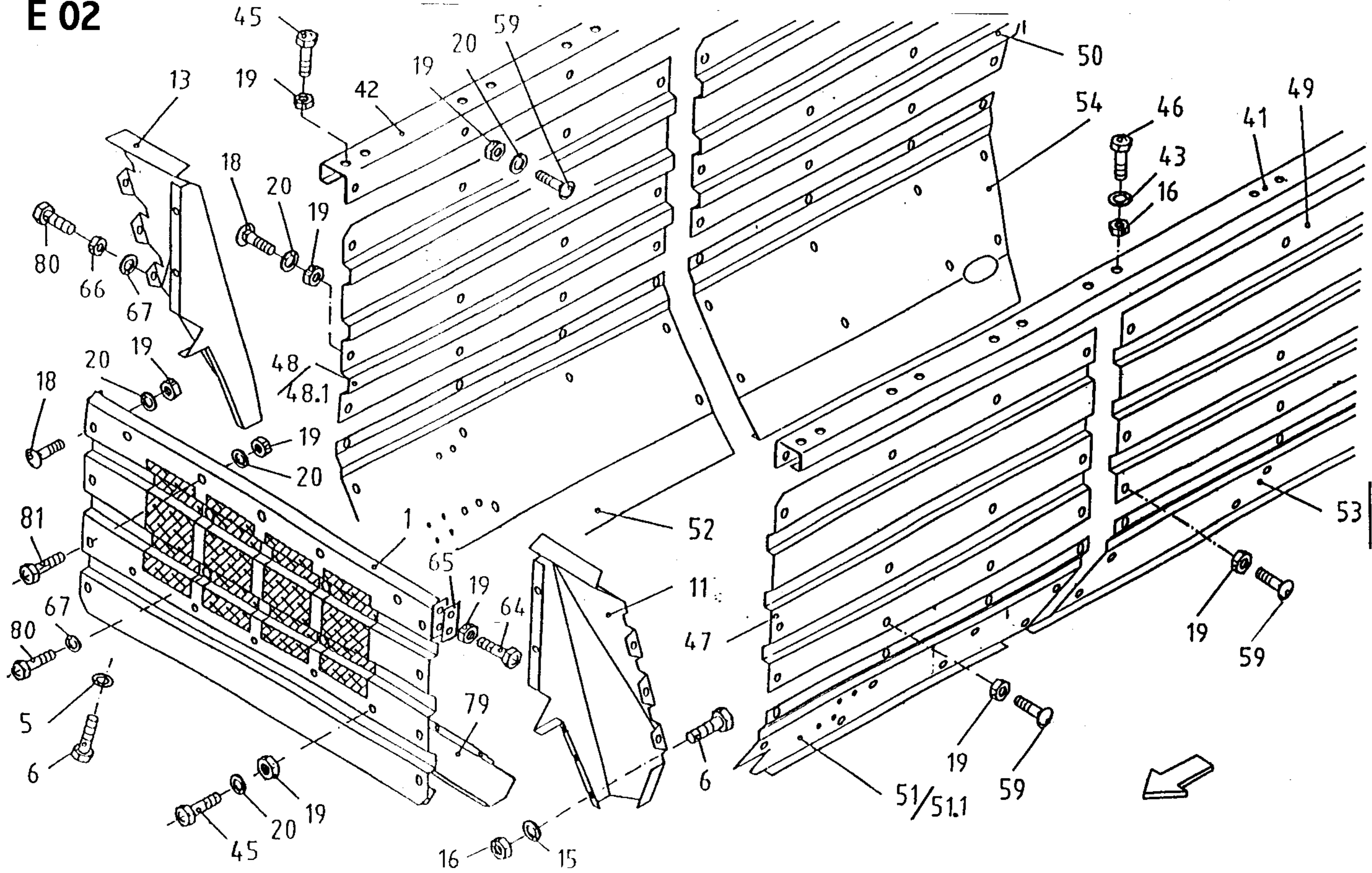

Bildtafel E02

Diagram

Diagrama

Diagramme

Bemerkungen

Notes

Notes

Notas

Pos.	Teile-Nr.	Menge	Benennung	Description	Designation	Denominacion
Pos.	Part.Nr.	Qty.				
Pos.	Piece No.	Qte.				
Pos.	Pieza No.	Cat.				
1	1651 6400	1	Frontwand gsw.	FRONT WALL	PAROI AVANT	TABIQUE FRONTAL
5	0112 7538	7	Shb. 10,5 DIN 7349	WASHER	RONDELLE	ARANDELA
6	0111 2429	11	Shr. M 10x30 88A3C	HEX. HEAD SCREW	VIS TETE 6-PANS	TORN.CAB. HEXAGONAL
11	1663 0342	1	Eckblech li. gsw.	CORNER SHEET	EQUERRE	ANGULO
13	1651 6311	1	Eckblech re. gsw.	CORNER SHEET	EQUERRE	ANGULO
15	0621 4197	8	Schb.10,5x30x3 A3C	WASHER	RONDELLE	ARANDELA
16	0620 9768	38	Sich.Mutter M10 A3C	LOCK NUT	ECROU DE SECURITE	TUERCA DE SEGURIDAD
18	0620 7534	18	Shr.M8x 20 8.8 A3C	SAUCER HEAD SCREW	VIS A TETE BOMBEE	TORN. CAB. BOMBEADA
19	0110 4944	176	Sich. Mu. M8 8A3C	LOCK NUT	ECROU DE SECURITE	TUERCA DE SEGURIDAD
20	0621 4192	92	Scheibe 8,4x25x3 A3C	WASHER	RONDELLE	ARANDELA
21	0620 7535	17	Shr.M 8x 16 8.8 A3C	OVAL HEADED BOLT	VIS TETE DEMI RONDE	TORNILLO CAB.BOMB
41	1663 0322	1	Scheuerleiste li.gsw.	CROSS BAR	BARRETTE	LISTON
42	1663 0325	1	Scheuerleiste re.gsw.	CROSS BAR	BARRETTE	LISTON
43	0110 7105	4	Scheibe 10,5x21x	washer	rondelle	arandela
45	0111 2333	12	Shr.M 8x25 88A3C	HEX. HEAD SCREW	VIS TETE 6-PANS	TORN.CAB. HEXAGONAL
46	0111 2429	34	Shr.M 10x25 88A3C	HEX. HEAD SCREW	VIS TETE 6-PANS	TORN.CAB. HEXAGONAL
47	1663 0310	1	Gr.Seitenwand vo.li.	SIDE WALL	PAROI LATERALE	PARED LATERAL
47.1	1663 0312	1	Gr.Seitenwand vo.li.	side wall	paroi laterale	PARED lateral
48	1663 0311	1	Gr.Seitenwand vo.re.	SIDE WALL	PAROI LATERALE	PARED LATERAL
48.1	1663 0313	1	Gr.Seitenwand vo.re.	side wall	paroi laterale	pared lateral
49	1663 0314	1	Gr.SEITENWAND LI.HI.	SIDE WALL	PAROI LATERALE	PARED LATERAL
50	1663 0315	1	Gr.SEITENWAND RE.HI.	SIDE WALL	PAROI LATERALE	PARED LATERAL
51	1663 0316	1	Kl.Seitenwand VO.LI.	SIDE WALL	PAROI LATERALE	PARED LATERAL
51.1	1663 0318	1	Kl.Seitenwand vo.li.	side wall	paroi lateral	pared lateral
52	1663 0317	1	KL.SEITENWAND VO.RE.	SIDE WALL	PAROI LATERALE	PARED LATERAL
52.1	1663 0319	1	Kl.Seitenwand vo.re.	side wall	paroi lateral	pared lateral
53	1663 0320	1	KL.SEITENWAND LI.HI.	SIDE WALL	PAROI LATERALE	PARED LATERAL
54	1663 0321	1	KL.SEITENWAND RE.HI.	SIDE WALL	PAROI LATERALE	PARED LATERAL
59	0114 2565	122	FIRD.Shr. M 8x20	TRUSS. HEAD SCREW	VIS TETE BOMBEE	TORN.CAB.SEMIRED.
64	0111 1153	4	Shr.M8x45 8.8 A3C	HEX. HEAD SCREW	VIS TETE 6-PANS	TORN.CAB. HEXAGONAL
65	1663 0305	4	Beilage			
66	0111 4357	6	Mu. M6 8A3C	LOCK NUT	ECROU DE SECURITE	TUERCA DE SEGURIDAD
67	0621 4189	22	Scheibe 6,4x18x2	WASHER 6,4X18X2	RONDELLE 6,4X18X2	ARANDELA 6,4X18X2
79	0657 2448	1	ABWEISBLECH	DEFL.SHEET	TOLE	CHAPA
80	0111 2264	6	Shr. M 6x20 DIN 933	HEX. HEAD SCREW	VIS TETE 6-PANS	TORN.CAB. HEXAGONAL
81	0111 2341	3	Shr. M 8x30 8.8 A3C	HEX. HEAD SCREW	VIS TETE 6-PANS	TORN.CAB. HEXAGONAL

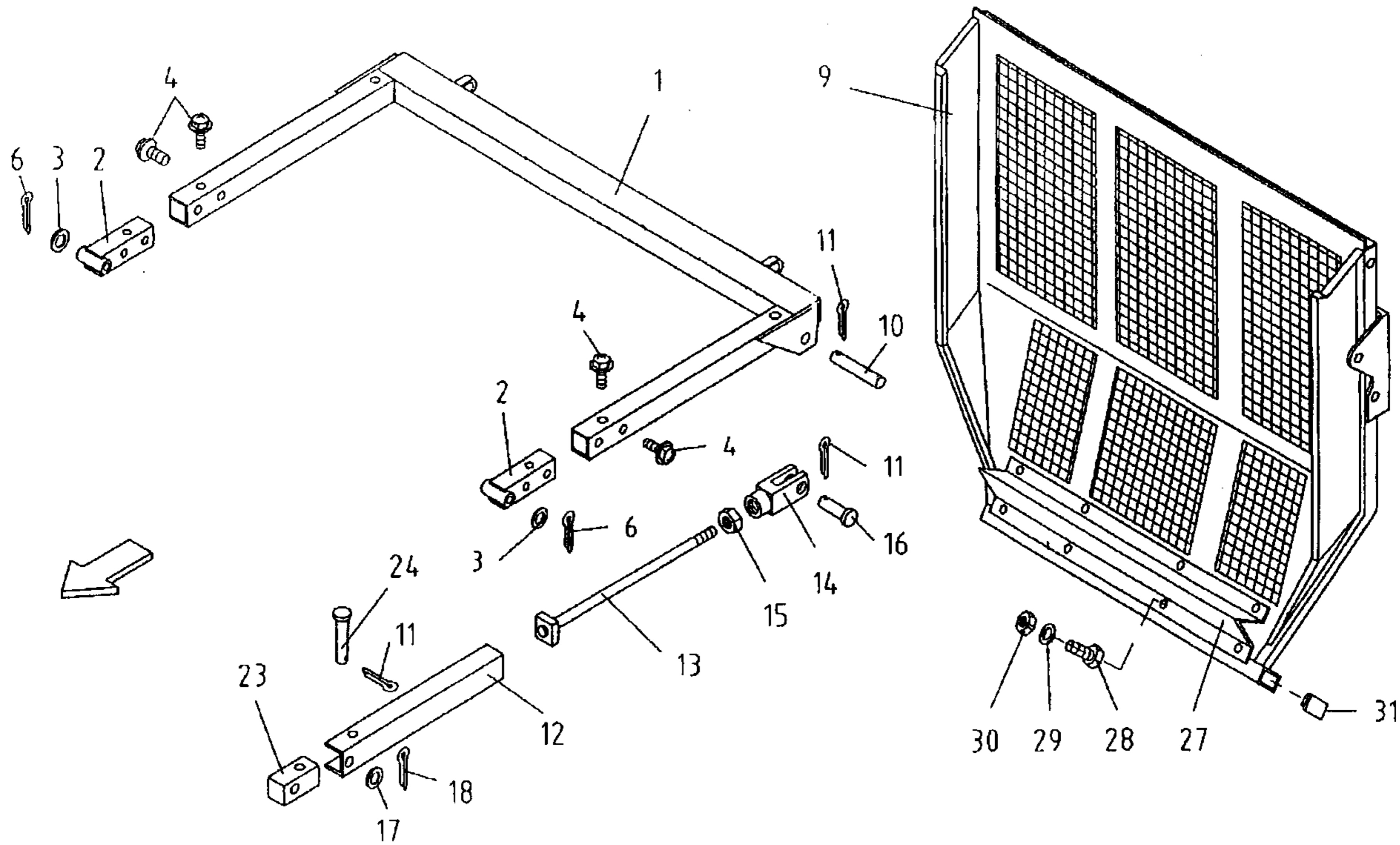

Rückwand

rear wall

paroi arriere

chapa pared detras

Bildtafel E03

Diagram

Diagramme

Diagrama

Bemerkungen

Notes

Notes

Notas

Pos.	Teile-Nr.	Menge	Benennung	Description	Designation	Denominacion
Pos.	Part.Nr.	Qty.				
Pos.	Piece No.	Qte.				
Pos.	Pieza No.	Cat.				
1	1663 0501	1	TRAGRAHMEN GSW.	SUPPORT FRAME	CADRE PORTEUR	BASTIDOR PORTANTE
2	1661 2594	2	LAGERSTUECK	SUPPORT	SEGMENT PALIER	PZA.SOPORTE
3	0112 8377	4	SCHB.26,0 DIN 126	WASHER/DISC/PLATE	RONDELLE/DISQUE	DISCO/ARANDELA
4	0114 2323	6	RIPP-SCHRAUBE	HEX.BOLT	VIS 6 PANS	TORNILLO HEXAGONAL
6	0113 2647	4	Splint 6,3x40	SPLIT PIN	GOUPILLE FENDUE	PASADOR DE ALETAS
9	1661 2500.01	1	RÜCKWAND GSW.	REAR WALL	PAROI ARRIERE	PARED TRASERA
10	1663 0498	2	Bolzen	PIN	AXE	PERNO
11	0110 6451	4	Splint 4 x 25 A3C	SPLIT PIN	GOUPILLE FENDUE	PASADOR DE ALETAS
12	1661 2343	2	TELESKOPSCHIENE	TELESCOPIC RAIL	RAIL TELESCOPIQUE	CARRIL TELESCOPICO
13	1661 2347	2	ZUGSTANGE	PULLROD	TIRANT	BARRA TRACCION
14	0139 7600	2	Gabelk.G16x32 D71752	CLEVIS	CHAPE	CABEZA HORQUILLA
15	0113 8938	2	MU.BM16	HEX. NUT	ECROU 6 PANS	TUERCA HEXAGONAL
16	0621 0028	2	BLZ.D1434-16H11	PIN	AXE	PERNO
17	0621 4226	2	Schb.21,0 D125 A3C	WASHER	RONDELLE	ARANDELA
18	0112 2072	2	Splint 5x32 D94 A3C	SPLIT PIN	GOUPILLE FENDUE	PASADOR ALETAS
23	1661 2351	2	Lagerkörper	BEARING HOUSING	CORPS DE PALIER	CUERPO COJINETE
24	0621 0030	2	BL.D434-16H11x55x47	PIN	AXE	PERNO
27	1661 2526	1	ABSTREIFBLECH	Scraper	RACLEUR	CHAPA RASPADOR
28	0111 2322	8	Shr. M8x20 8.8 A3C	HEX. HEAD SCREW	VIS TETE 6-PANS	TORN.CAB. HEXAGONAL
29	0621 4195	8	Schb.9,0x17,0x2,5	WASHER	RONDELLE	ARANDELA
30	0110 4944	8	Sich.Mu. M8 8A3C	LOCK NUT	ECROU DE SECURITE	TUERCA DE SEGURIDAD
31	0114 2360	2	VIERKANTSTOPFEN	SQUARE PLUG	BOUCHON 4 PANS	TAPON CUADRADILLO

E 06

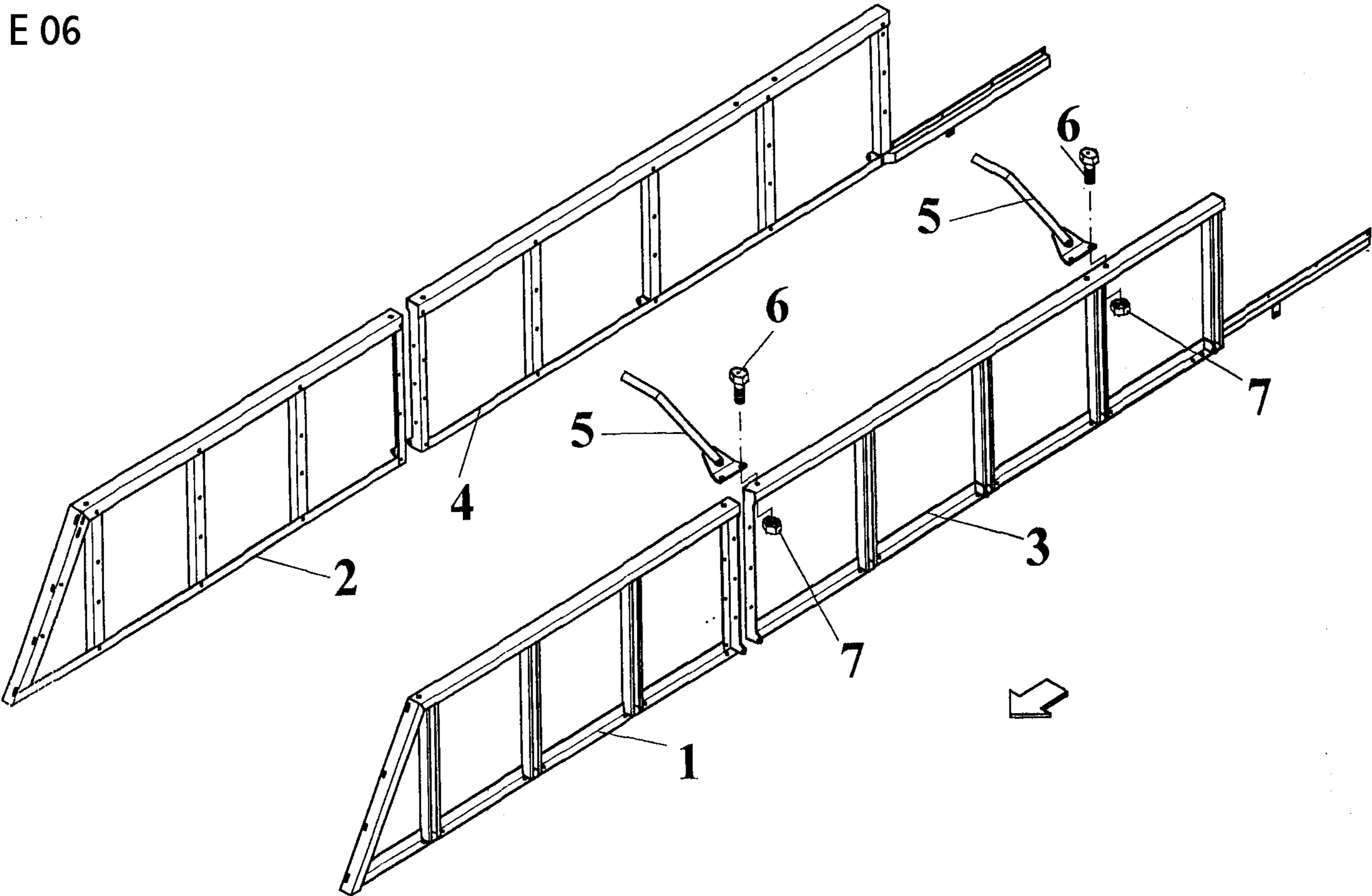

Aufbau starr rigid mounting motage rigide montaje rigido

Bildtafel E06

Diagram
Diagramme
Diagrama
Bemerkungen

Notes
Notes
Notas

Pos.	Teile-Nr.	Menge	Benennung	Description	Designation	Denominacion
Pos.	Part.Nr.	Qty.				
Pos.	Piece No.	Cat.				
Pos.	Pieza No.	Qte.				
1	1663 0560	1	Rahmen vo.li.gsw.	FRAME	CHASSIS	CHASIS
2	1663 0570	1	Rahmen vo.re.gsw.	FRAME	CHASSIS	CHASIS
3	1663 0580	1	Rahmen hi.li.gsw.	FRAME	CHASSIS	CHASIS
4	1663 0585	1	Rahmen hi.re.gsw.	FRAME	CHASSIS	CHASIS
5	1663 0365	2	Dachbügel gsw.	BOW/YOKE	CADRE/ETRIER	ESTRIBO
6	0110 2429	8	Shr.M10x30 88A3C	LOCK NUT	ECROU DE SECURITE	TUERCA DE SEGURIDAD
7	0620 9768	8	Sich.-Mu.M10 A3C	HEX. HEAD SCREW	VI TETE 6-PANS	TORN.CAB.HEXAGONAL

E 07

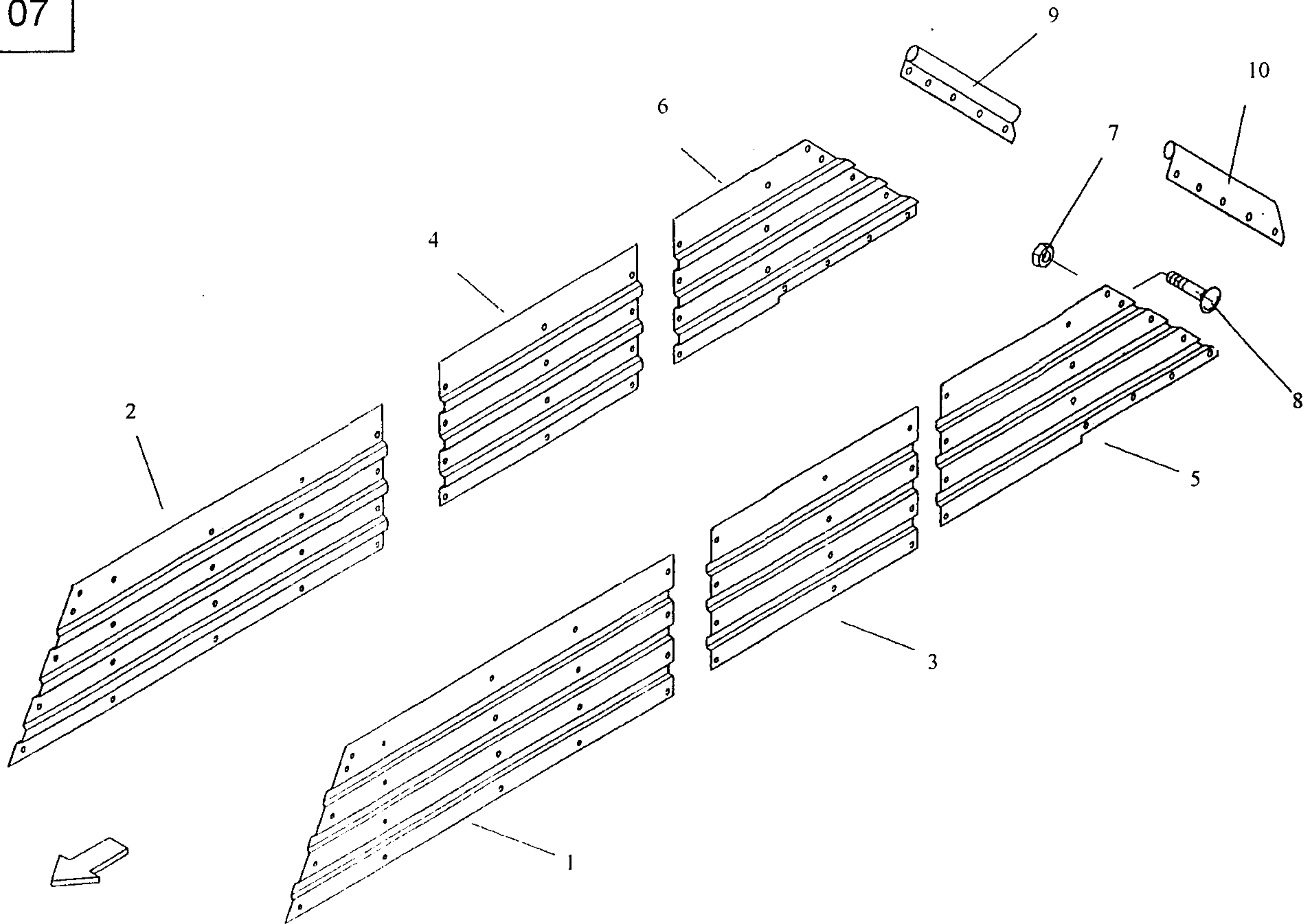

Aufbau Starr
Seitenwände

rigid mounting
side wall

montage rigide
parot laterale

montaje rigido
pared lateral

Bildtafel E07

Diagram

Diagramme

Diagrama

Bemerkungen

Notes

Notes

Notas

Pos.	Teile-Nr.	Menge	Benennung	Description	Designation	Denomination	
Pos.	Part.Nr.	Qty.					
Pos.	Piece No.	Qte.					
Pos.	Pieza No.	Cat.					
1	1663 0354	1	Seitenwand vo.li.	side wall	paroi laterale	pared lateral	
2	1663 0355	1	Seitenwand vo.re.	side wall	paroi laterale	pared lateral	
3	1663 0356	1	Seitenwand mi.li.	side wall	paroi laterale	pared lateral	
4	1663 0357	1	Seitenwand mire.	side wall	paroi laterale	pared lateral'	
5	1663 0358	1	Seitenwand hi.li.	side wall	paroi laterale	pared lateral	
6	1663 0359	1	Seitenwand hire.	side wall	paroi laterale	pared lateral	
7	0110 4944	94	Sich.Mu.M8 8A3C	LOCK NUT	ECROU DE SECURITE	TUERCA DE SEGURIDAD	
8	0114 2565	94	Flrd.Shr.M 8x20	TRUSS-HEAD SCREW	VIS TETE BOMBEE	TORN.CAB.SEMIRED.	
9	1651 5703	1	RANDLEISTE OBEN LI.	CROSS BAR	BARRETTE	LISTON	
10	1651 5704	1	RANDLEISTE OBEN RE.	CROSS BAR	BARRETTE	LISTON	

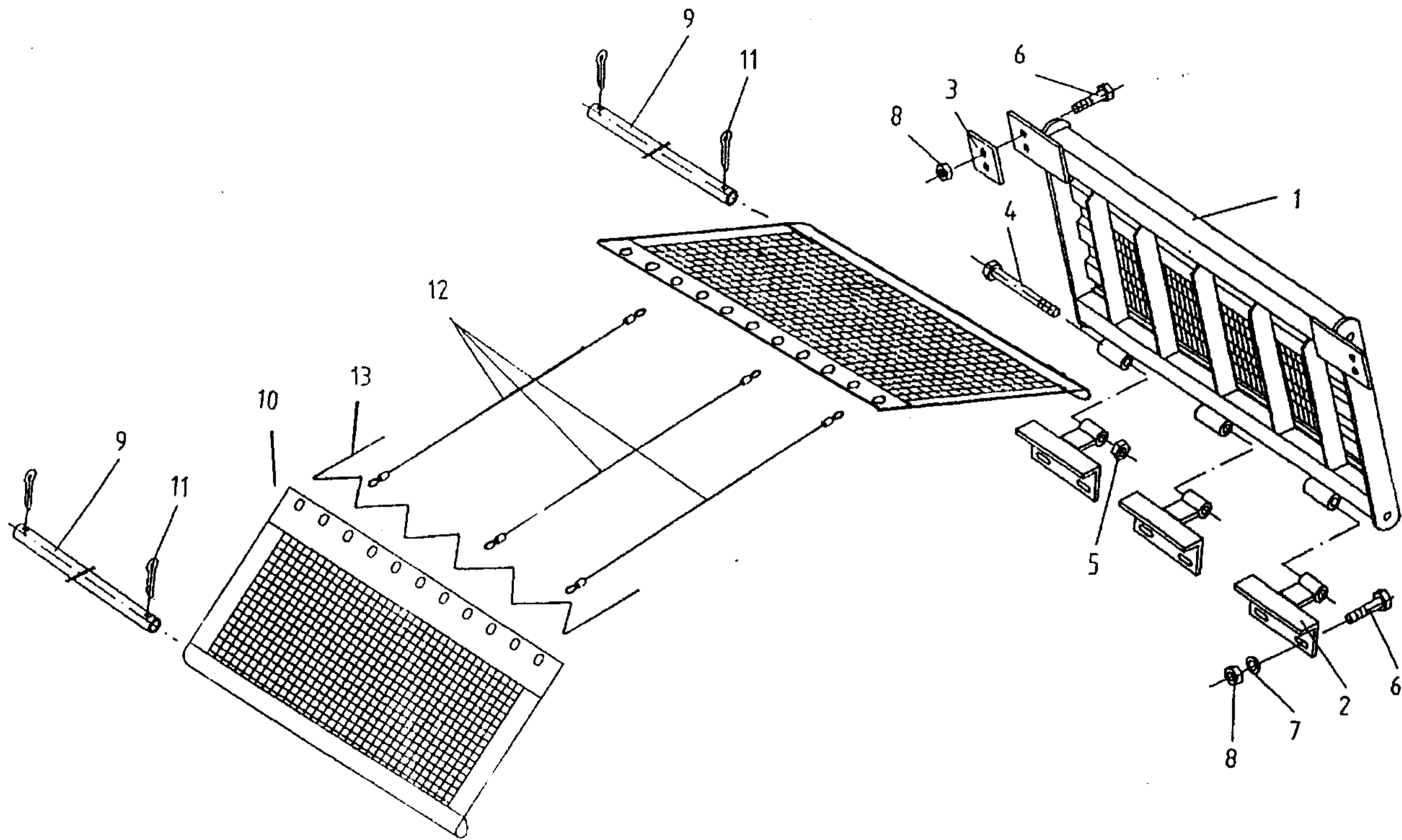

Bildtafel E08Diagram
DiagrammeDiagrama
Bemerkungen
Notes
Notes
Notas

			Aufbau starr Tuch und Seile	rigid mounting canvas and cables	montage rigide toile et cables	montaje rigido tela y cables	
Pos.	Teile-Nr.	Menge	Benennung	Description	Designation	Denomination	
Pos.	Part.Nr.	Qty.					
Pos.	Piece No.	Qte.					
Pos.	Pieza No.	Cat.					
1	1663 0371	1	FRONTWAND OBEN GSW.	AIR CLEANER	FILTRE D'AIR COMPR	FILTRO AIRE COMPR.	
2	1651 5614	3	SCHARNIERWINKEL GSW.	HINGE ANGLE	EQUERRE	ANGULO	
3	1651 5613	2	LOCHPLATTE	PUCHED PLATE	PLAQUE PERFOREE	PLACA DERFORADA	
4	0111 1576	3	Shr. M 12x120 D931	hex. head screw	vis tete 6-pans	torn. cab hexagonal	
5	0620 9769	3	Mu. M u12 8A3C	Lock nut	Ecrou de securite	Tuerca de seguridad	
6	0111 2341	10	Shr.M 8x30 8.8 A3C	HEX. HEAD SCREW	VIS TETE 6-PANS	TORN.CAB. HEXAGONAL	
7	0621 4193	6	Schb.8,4x21x3 A3C	WASHER	RONDELLE	ARANDELA	
8	0110 4944	10	Sich.Mu. M8 8A3C	LOCK NUT	ECROU DE SECURITE	TUERCA DE SEGURIDAD	
9	1663 0374	2	HALTEROHR	FIXING TUBE	TUBE DE FIXATION	TUBO DE FIJACION	
10	1651 3065	2	NETZ HINTEN	NET	RESEAU/FILET	RED	
11	0110 6500	2	Splint 8 x 50	SPLIT PIN	GOUPILLE FENDUE	PASADOR DE ALETAS	
12	1663 0388	14	Seil 2800	CABLE/ROPE	CORDE/CABLE	CABLE	
13	1661 1363	1	Spannseil	TENSION CABLE	CABLE DE SERRAGE	CABLE TENSOR	

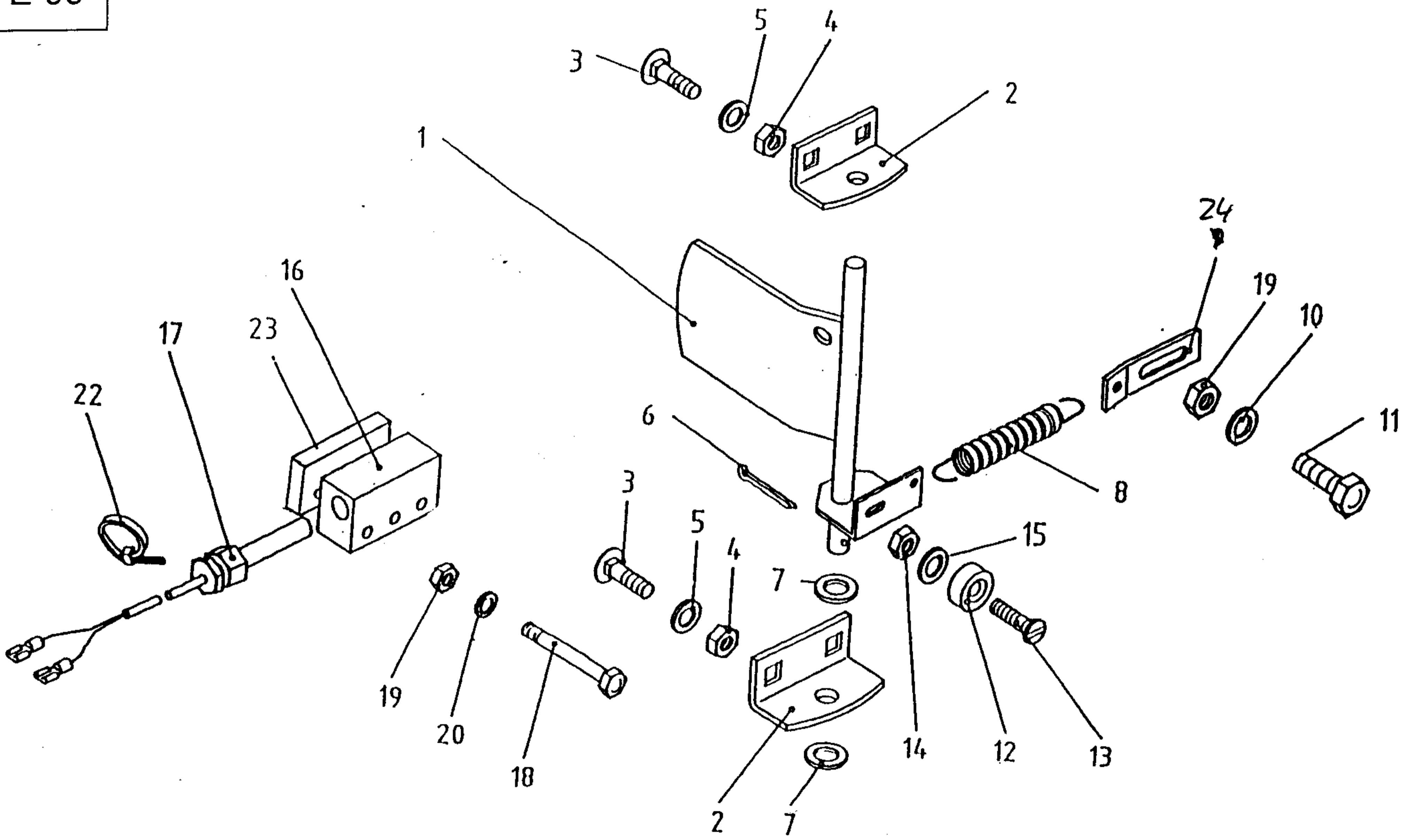

Bildtafel E09Diagram
Diagramme
Diagrama

Bemerkungen

Notes

Notes

Notas

			Füllstandsanzeiger	level indicator	indicateur de niveau	indicador de nivel	
Pos.	Teile- Nr.	Menge	Benennung	Description	Designation	Denomination	
Pos.	Part. Nr.	Qty.					Notes
Pos.	Piece No.	Qte.					Notes
Pos.	Pieza No.	Cat.					Notas
1	1651 8205	1	KLAPPE GSW.	FLAP/COVER	CLAPET/TRAPPE	TRAMPILLA	
2	1651 1632	2	HALTER	RETAINER	SUPPORT/PORTEQUTIL	SOPORTE	
3	0113 8993	4	SHR.M8X16 D603	TRUSS-HEAD SCREW	VIS TETE BOMBEE	TORN.CAB.SEMIRED.	
4	0110 4944	4	Sich. Mu.M8 8Á3C	LOCK NUT	ECROU DE SECURITE	TUERCA DE SEGURIDAD	
5	0110 7163	4	Schb. 9x17x1,6 A3C	WASHER	RONDELLE	ARANDELA	
6	0110 6451	1	Splint 4 x 25 A3C	SPLIT FIN	GOUPILLE FENDUE	PASADOR DE ALETAS	
7	0621 4215	2	18x30x1,5	WASHER	RONDELLE	ARANDELA	
8	0621 5513	1	Z.FED.2,0/16,0/116,0	TENSION SPRING	RESSORT DE RAPPEL	MUELLE DE TRACCION	
10	0621 4353	1	SCHB. 6,4X18,0X2,0	WASHER/DISC/PLATE	RONDELLE/DISQUE	DISCO/ARANDELA	
11	0110 3316	1	Shr. M6*16 8.8 A3C	HEX. HEAD SCREW	VIS TETE 6-PANS	TORN.CAB. HEXAGONAL	
12	1651 4462	1	Magnet	MAGNET/SOLENOID	AIMANT/ELECTROAIM.	MAGNETO/ELECTROIMA	
13	0113 2262	1	Shr. M4`20 48Á3C	C`SUNK SCREW	VIS TETE NOYEE	TORN.CABZA.EMBUTID	
14	0620 9764	1	Mu.M4 8Á3C	HEX.NUT	ECROU 6 PANS	TUERCA HEXAGONAL	
15	0111 9806	1	SCHB. 4,3 DIN9021	WASHER/DISC/PLATE .	RONDELLE/DISQUE	DISCO/ARANDELA	
16	1651 7215	1	SCHALTERGEHAEUS9	SWITCH HOUSING	CORPS INTERRUPT	CAJA CONMUTADOR	
17	1651 7799	1	Magnetschalter	MAGNETIC SWITCH	COMMUT DE MAGNETO	CONMUT.ELECTR.MAGN	
18	0111 1083	2	Shr.M6X60 D931	HEX. HEAD SCREW	VIS TETE 6-PANS	TORN. CAB. HEXAGONAL	
19	0111 4357	3	Mu.M6 8Á3C	LOCK NUT	ECROU DE SECURITE	TUERCA DE SEGURIDAD	
20	0621 4189	2	Scheibe 6,4x18x2	WASHER 6,4X18X2	RONDELLE 6,4X18X2	ARANDELA 6,4X18X2	
22	0621 6479	6	Kabelbinder 3,6x140	CABLE BTNDER	COLLIER DE CABLE	COLLAR DE CABLE	
23	1663 0487	1	Distanzplatte				
24	1661 1244	1	LASCHE	CONNECTING PLATE	ECLISSE	ECLISA	
25	0139 7920	2	Steckhülse 2,8x1,5RT	PLUG-III SLEEVE	ALVEOLE	CASQUILLO ENCHUFE	

F 01

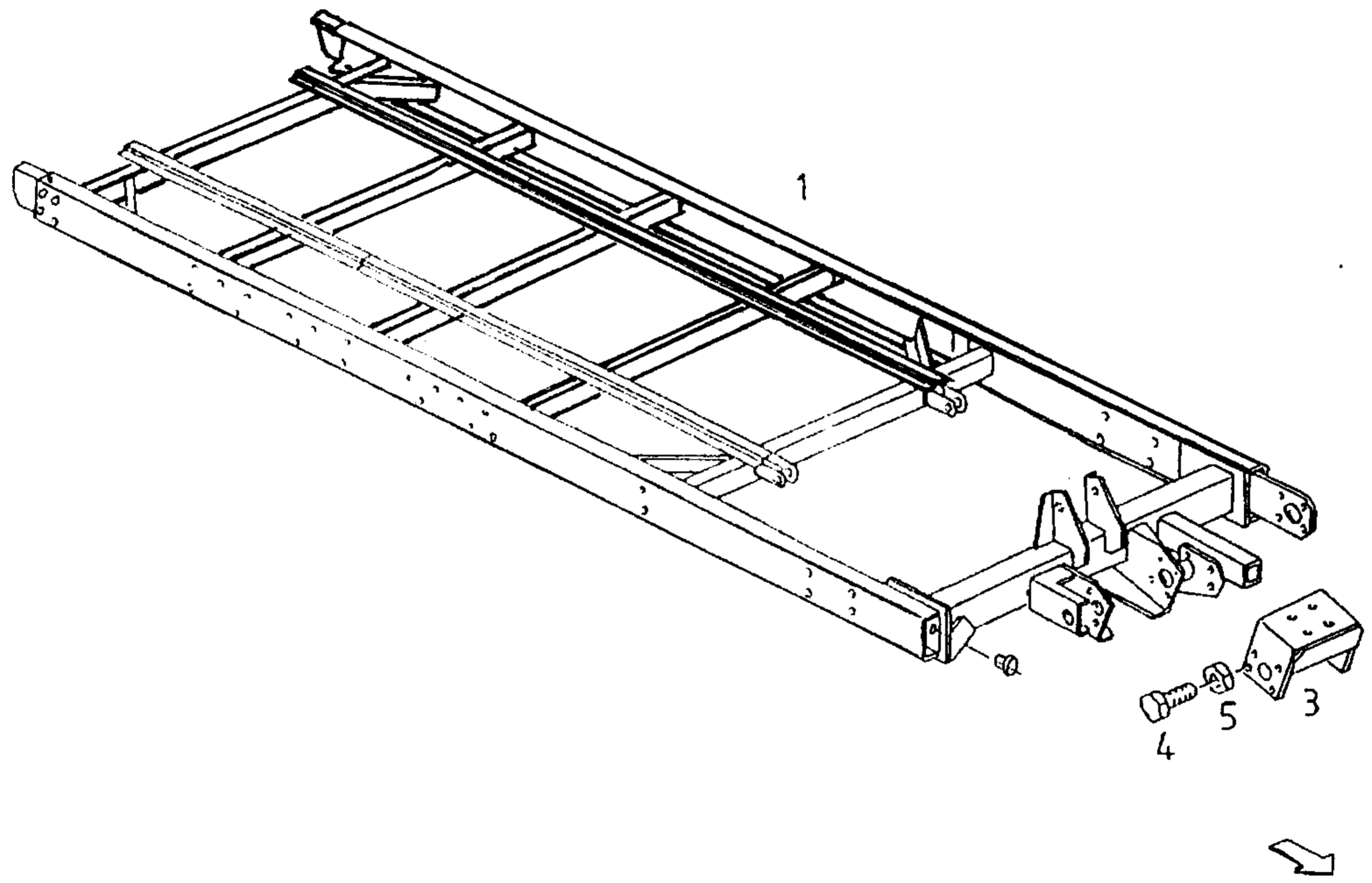

Rahmen

frame

chassis

chasis

Bildtafel F 01

Diagram

Diagramme

Diagrama

Bemerkungen

Notes

Notes

Notas

Pos.	Teile-Nr.	Menge	Benennung	Description	Designation	Denomination
Pos.	Part.Nr.	Qty.				
Pos.	Piece No.	Qte.				
Pos.	Pieza No.	Cat.				
1	1663 0240	1	Fahrgestellrahmen	CHASSIS FRAME	CADRE DE CHASSIS	BASTIDOR CHASIS
3	0657 5228	1	Getriebekonsole	BRACKET	CONSOLE D'ENGREN	CONSOLA
4	0111 2687	4	Shr.M16x40 D933	hex. head screw	VIS TETE 6-PANS	TORN.CAB.HEXAGONAL
5	0112 7856	4	SichMu.M16 D985 8A3C	LOCK NUT	ECROU DE SECURITE	TUERCA DE SEGURIDAD
6	1663 0248	2	Führungsschiene	GUIDE RAIL	RAIL-GUIDE	CARRIL GUIA

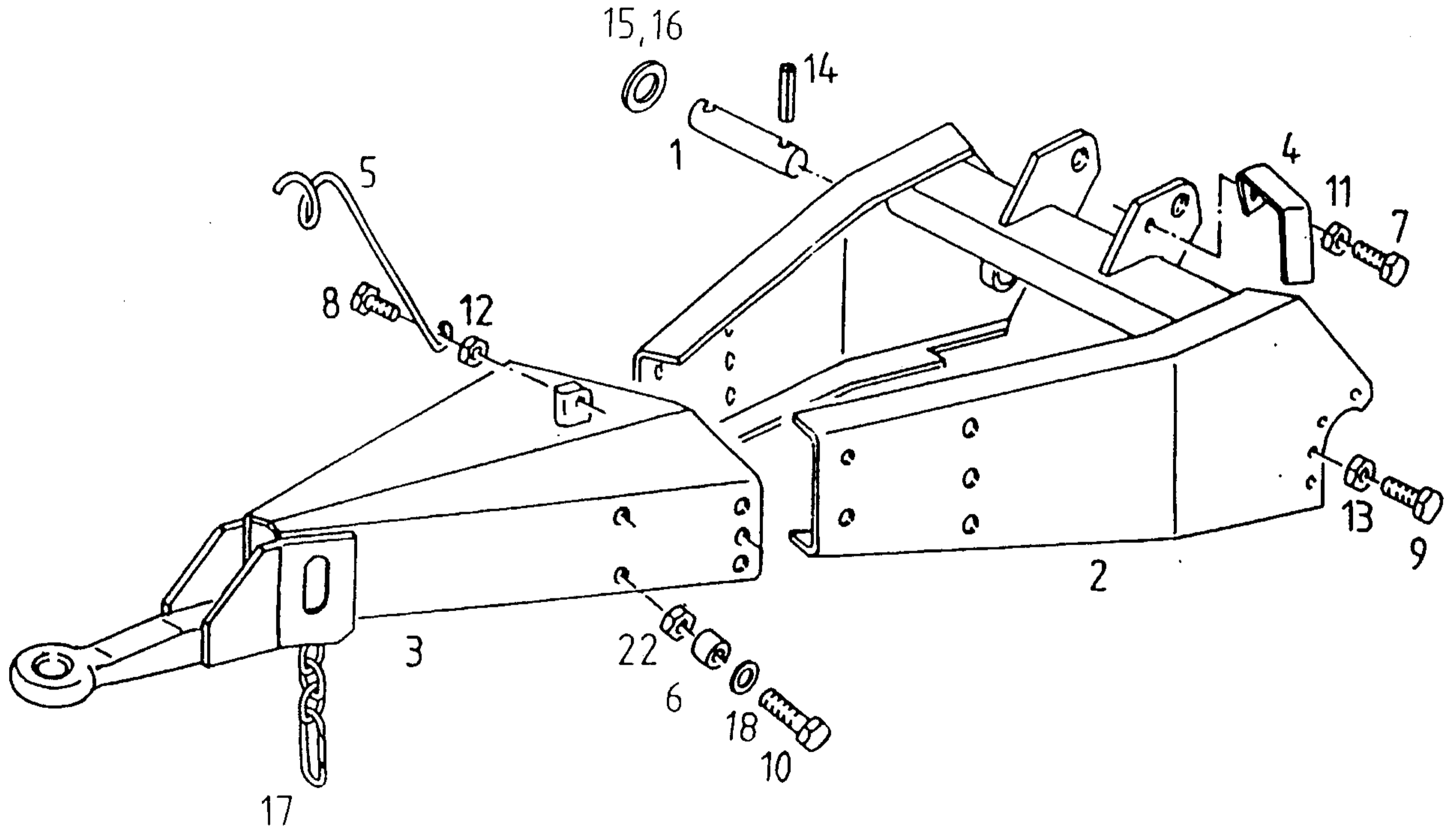

Bildtafel F04

			Zugdeichsel Z 240	traction bar	barre de traction	barra de traccion	Diagram Diagramme Diagrama
Pos.	Teile-Nr.	Menge	Benennung	Description	Designation	Denomination	Bemerkungen
Pos.	Part.Nr.	Qty.					Notes
Pos.	Piece No.	Qte.					Notes
Pos.	Pieza No.	Cat.					Notas
1	0655 4790	1	Bolzen	PIN	AXE	PERNO	
2	1651 3238	1	Deichsel gsw.	DRAWBAR	TIMON	TIMON	
3	1651 5251	1	ZUGVORRICHTUNG	TRACTION BAR	BARRE DE TRAC TION	BARRA DE TRACTION	
4	1663 0283	1	SCHLAUCHHALTER	CLAMPING PIECE	COLLIER	ABRAZADERA	
5	0655 8567	1	STUETZE	SUPPORT	SUPPORT	SOPORTE	
6	0657 5227	8	Abstandring	SPACER RING	BAGUE ECARTEMENT	ARO DISTANCIARIO	
7	0111 2333	1	Shr. M 8x25 88A3C	HEX. HEAD SCREW	VIS TETE 6-PANS	TORN.CAB. HEXAGONAL	
8	0]11 2418	1	Shr. 11 10x25 88A3C	HEX. HEAD SCREW	VIS TETE6-PANS	TORN.CAB. HEXAGONAL	
9	0111 2687	4	SHR.M16x10 D933	HEX. HEAD SCREW	VIS TETE 6-PANS	TORN.CAB. HEXAGONAL	
10	0111 1867	8	SHR.M16x60 D931 10.9	HEX.BOLT	VIS 6 PANS	TORNILLO HEXAGONAL	
11	0110 4944	1	Sich. Mu. M8 8A3C	LOCK NUT	ECROU DE SECURITE	TUERCA DE SEGURIDAD	
12	0620 9768	1	Sich.-Mutter M10 A3C	LOCK NUT	ECROU DE SECURITE	TUERCA DE SEGURIDAD	
13	0112 7856	4	Si.Mu.M16 D9B5 8A3C	LOCK NUT	ECROU DE SECURITE	TUERCA DE SEGURIDAD	
14	0111 5478	2	Spannstift 8x50 A3C	DOWEL PIN	GOUPILLE SERRAGE	PERNO FIADOR	
15	0113 7526	1	Stützschr. 35x45x2,5	WASHER	RONDELLE	ARANDELA	
16	0621 4486	1	Pass-Schr. 35x45x1,0	SPACER	RONDELLE D'EPAISSEUR	ARANDELA DE ESPESOR	
17	1661 1356	1	Kette	CHAIN/TPACK	CHAINE/CHENILLE	CADENA	
18	0114 2556	16	Spannscheibe	SPACING RING	RONDELLE SERRAGE	ARANDELA FIJACION	
22	0110 0590	8	Mutter M16 10 A3C	LOCK NUT	ECROU DE SECURITE	TUERCA DE SEGURIDAD	

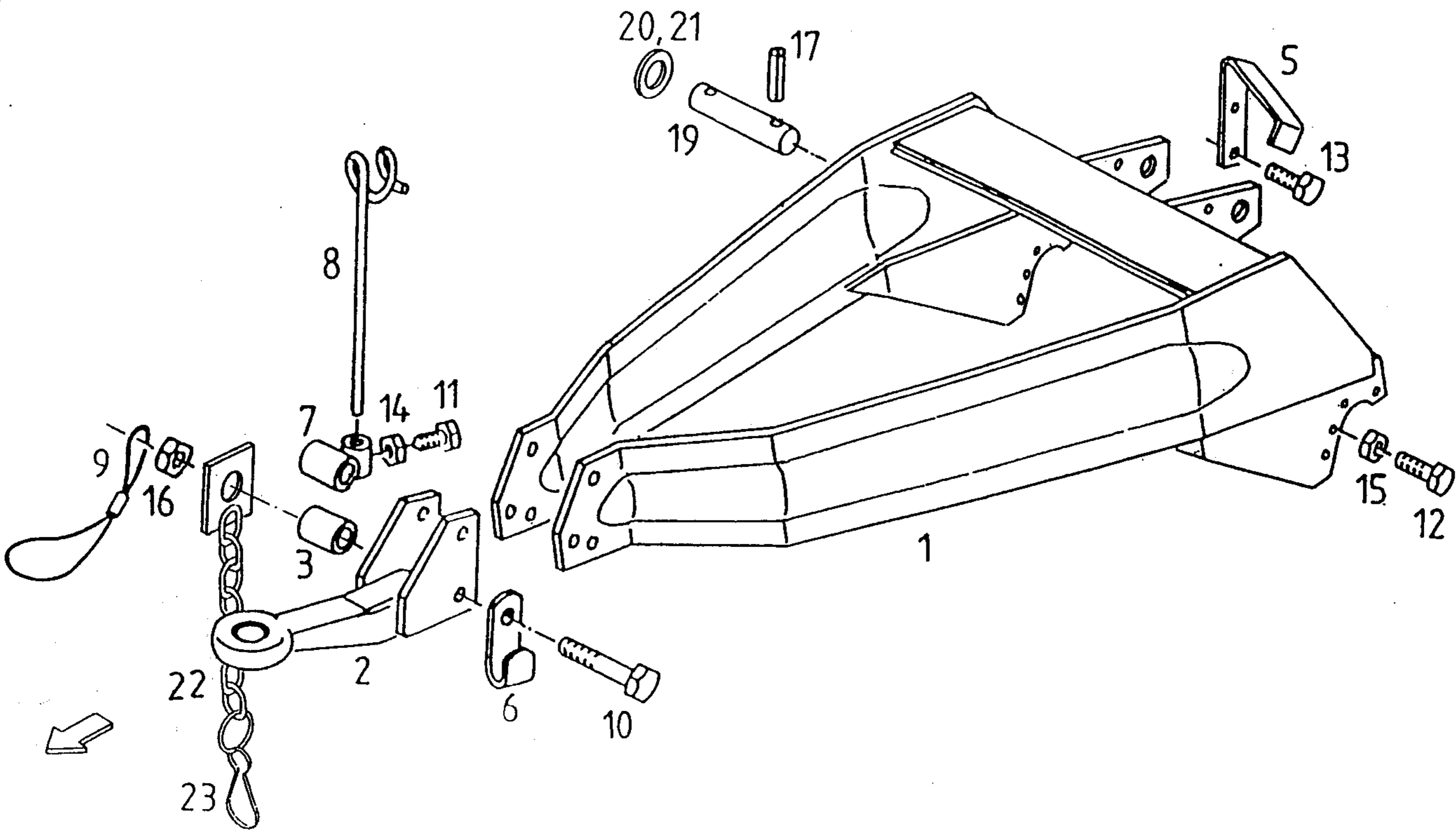

Zugdeichsel Z450 traction bar barre de traction barra de traction
 nur ausserhalb D !!

Bildtafel F05

Diagram
 Diagramme
 Diagrama
 Bemerkungen
 Notes
 Notes
 Notas

Pos.	Teile-Nr.	Menge	Benennung	Description	Designation	Denomination
Pos.	Part.Nr.	Qty.				
Pos.	Piece No.	Qte.				
Pos.	Pieza No.	Cat.				
1	1651 3246	1	DEICHSEL GSW.	DRAWBAR	TIMON	TIMON
2	1651 3477	1	ZUGOESE GSW.	DRAWBAR EYE	OUILLET TRACTION	ARGOLLA TRACTION
3	0655 4525	1	ROHR L=59,5	TUBE	TUBE	TUBO
5	0655 8565	1	SCHLAUCHHALTER	CLAMPING PIECE	COLLIER	ABRAZADERA
6	0655 8561	1	WINKFT.	ANGLE	EQUERRE	ANGULO
7	0655 8562	1	ROHR GESCHW.	TUBE	TUBE	TUBO
8	0655 8569	1	STUETZE	SUPPORT	SUPPORT	SOPORTE
9	0658 7235	1	FANGSCHLAUFE	SAFETY CABLE	CABLE DE SECURITE	CABLE DE SEGURIDAD
10	0113 6666	2	SHR.M20X150D931	HEX. HEAD SCREW	VIS TETE 6-PANS	TORN.CAB. HEXAGONAL
11	0111 2307	1	SHR. M H:í16 D933	HEX. HEAD SCREW	VIS TETE 6-PANS	TORN.CAB. HEXAGONAL
12	0111 2687	4	SHR.M16X 40D933	HEX. HEAD SCREW	VIS TETE 6-PANS	TORN.CAB. HEXAGONAL
13	0620 9473	2	Shr. M 8x.16 DIN 933	HEX.HEAD SCREW	VIS TETE 6-PANS	TORN.CAB.HEXAGONAL
14	0111 2824	1	Mu. M 8 8A3C HEX.	NUT	ECROU 6-PANS	TUERCA HEXAGONAL
15	0112 7856	4	Si.Mu.M16 D985 8A3C	LOCK. NUT	ECROU DE SECURITE	TUERCA DE SEGURIDAD
16	0620 9774	2	Mu.M20 DIN985	LOCK NUT	ECROU DE SURETE	TUERCA DE SEGURIDAD
17	0111 5478	2	Spannstift 8x50 A3C	DOWEL PIN	GOUPILLE SERRAGE	PERNO FIADOR
19	0655 4790	1	Bolzen	PIN	AXE	PERNO
20	0113 7526	1	Stützschr. 35x45x2,5	WASHER	RONDELLE	ARANDELA
21	0621 4486	1	Pass Schb. 35x45x1,0	SPACER	RONDELLE D'EPAISSEUR	ARANDELA DE ESPESOR
22	1661 1433	1	LASCHE G ^s W.	connecting plate	eclisse	eclisa
23	0621 1876	1	K-HAKEN C60	SNAP HOOK	MOUSQUETON	MOSQUETON
24	0621 4226	4	Schb. 21,0 D125 A3C	WASHER	RONDELLE	ARANDELA
25	0112 0692	1	Schmiernippel AM6x1	GREASE NIPPLE	GRAISSEUR A PRESSION	ENGR. A PRESION

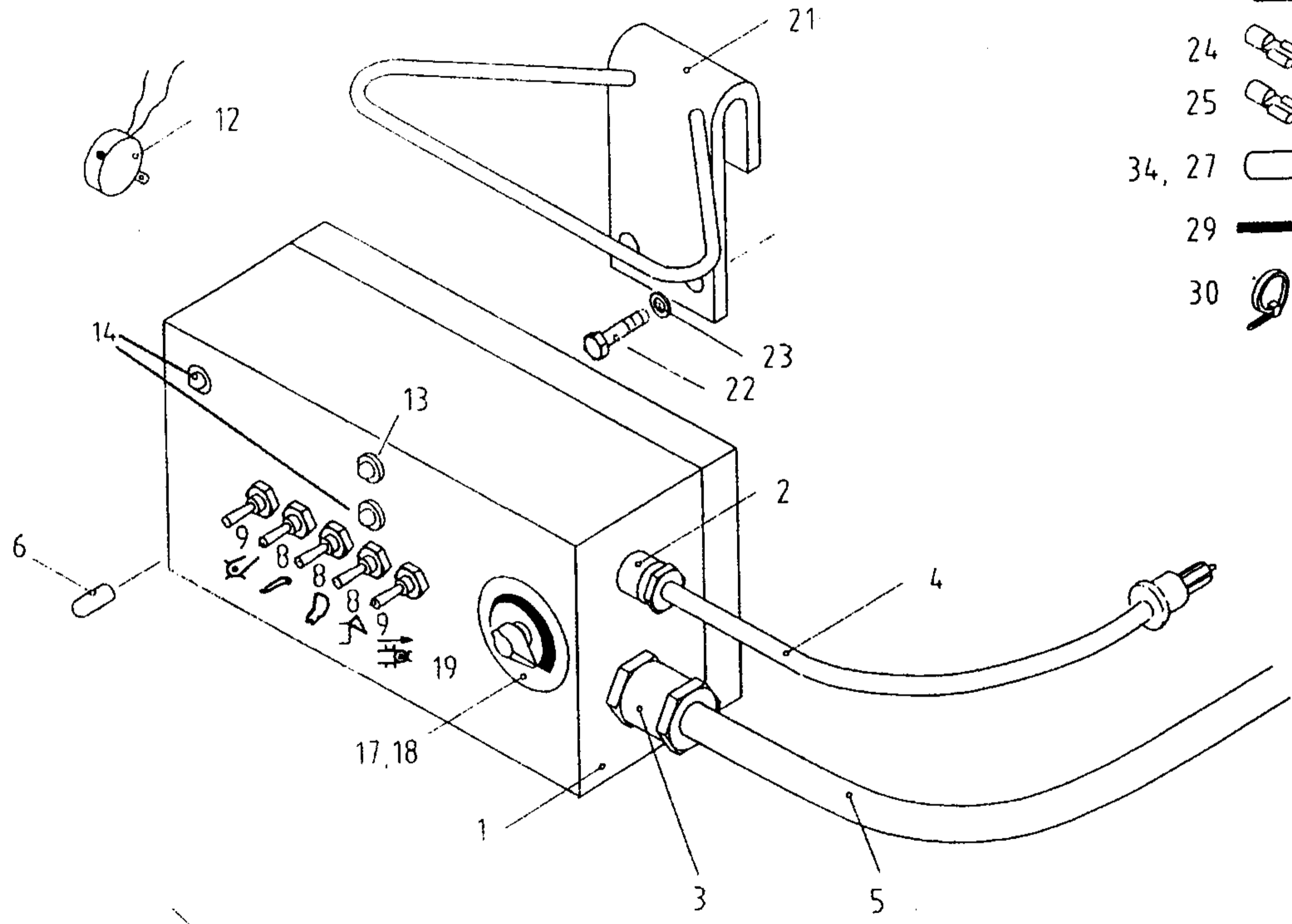

- 10
- 11
- 24
- 25
- 34, 27
- 29
- 30

Elektr. Steuereinheit
Pilotbox **1663 0480**

electr. Remote contr.
pilotbox

tele comman.elekt.
pilotbox

tele mando electr.
pilotbox

Bildtafel H01

Diagram

Diagramme

Diagrama

Bemerkungen

Notes

Notes

Notas

Pos.	Teile-Nr.	Menge	Benennung	Description	Designation	Denomination
Pos.	Part.Nr.	Qty.				
Pos.	Piece No.	Qte.				
Pos.	Pieza No.	Cat.				
1	1663 0890	1	Gehäuse mit Deckel	HOUSING/CASE	CARTER/BOITER	CAJA/BLOQUE/CUERPO
2	1663 0891	1	KAB.VERSCHR. PG 9	THEADED UNION	RACCORD VISSE	UNION ROSC P/TUBO
3	1651 5436	1	KAB.VERSCHR.SHZ16	THEADED UNION	RACCORD VISSE	UNION ROSC P/TUBO
4	1663 0892	1	Steckerltg. vollst.	Cable with plug	câble avec enfich	cable con enchufe
5	1663 0893	1	Verbindungskabel			
6	1651 5453	7	Kappe	CAP	CAPUCHON/CARLOTTE	SOMBRER./CABUCHON
8	1651 3931	3	Kippschalter	TOGGLE SWITCH	INTERRUPT A BASC	CONMUTAD.BASCULANT
9	1651 3932	2	Kippschalter	TOGGLE SWITCH	INTERRUPT A BASC	CONMUTAD.BASCULANT
10	0658 7052	1	Sicherungshalter	SUPPORT	SUPPORT	SOPORTE
11	0114 3017	1	Sicherungseinsatz	FUSE	FUSIBLE	FUSIBLE
12	0657 9959	1	Hupe	HORN	KLAXON	BOCINA
13	1663 0894	1	Lampe rot kpl.	LAMP	LAMPE	LAM P ARA
14	1663 0895	2	Lampe grün kpl.	LAMP	LAMPE	LAMPARA
17	1651 5449	1	Potentiometer	POTENTIONMETER	POTENTIOMETRE	POTENCIOMETRO
18	1663 0896	1	Drehknopf	ROTARY KNOB	BUTON TOURNANT	BOTON GIRATORIO
18.1	1663 0897	1	Kappe für Drehknopf			
19	1663 0898	1	Frontfolie			
21	1651 5468	1	Aufsteckbügel gsw.	yoke/retainer	etrier d fiche	estribo enchufe
22	0111 2240	2	Shr.M6x12 8.8 A3C	HEX.HEAD SCREW	VIS TETE 6 PANS	TORN. CAB. HEXAGONAL
23	0111 8645	2	D-RING	SEAL RING	JOINT	JUNTA
24	0621 3729	12	Flachsteckhülse 730	SLEEVE	DOUILLE	MANGUITO
25	1663 0899	3	Flachsteckhülse	SLEEVE	DOUILLE	MAN GUITO
27	1651 3942	1	Schrumpfschlauch	shrink hose	flex A fretter	manguerra contract.
29	1651 3943	1	Litze			
30	1663 0901	2	Kabelbinder 2,4x92	CABLE BINDER	COLLIER DE CABLE	COLLAR DE CABLE

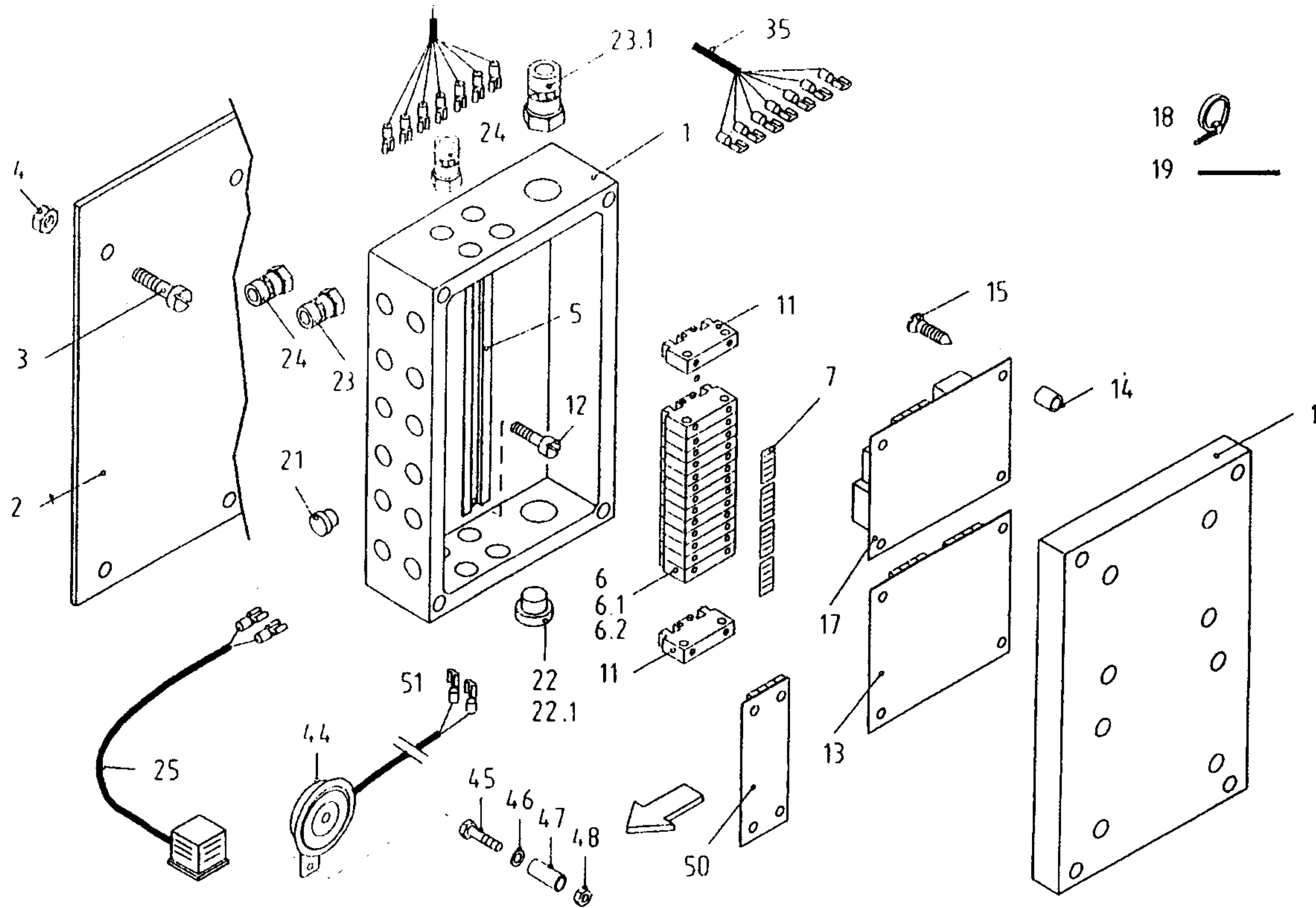

Schaltkasten

switch case for
remote controlboiter de manoeuv.
pour telecommandeCaja de distribution
para telemando**Bildtafel H02**

Diagram

Diagramme

Diagrama

Bemerkungen

Notes

Notes

Notas

Pos.	Teile- Nr.	Menge	Benennung	Description	Designation	Denomination
Pos.	Part. Nr.	Qty.				
Pos.	Piece No.	Qte.				
Pos.	Pieza No.	Cat.				
1	1651 8239	1	Verteilergehäuse	HOUSING	CARTER	CAJA DISTRIBUIDOR
2	1663 0335	1	Abdeckblech gsw.			
3	0110 5515	4	Zyl.Shr.AM4x16 f"4	CHEESE HEAD SCREW	VIS TETE CYLINDRIQUE	TORNILLO CILINDRICO
4	0620 9764	4	Mu.M4 8A3C	HEX.NUT	ECROU 6 PANS	TUERCA HEXAGONAL
5	1663 0902	1	WAGO Tragschiene	SUPPORT RAIL	SUPPORT	CARRIL SOPORTE
6	1663 0903	8	Anreihklemme 2-fach	TERMINAL	BORNE EN SERIE	BORNES EN SERIE
6.1	1663 0904	10	Anreihklemme 4-fach	TERMINAL	BORNE EN SERIE	BORNES EN SERIE
6.2	1663 0905	1	Abschlußplatte			
7	1663 0906	1	Etikett			
11	1663 0907	2	Endwinkel WAGO			
12	1651 8288	2	Zyl.Shr.AM3x20 D84	CHEESE HEAD SCREW	VIS TETE CYLINDRIQUE	TORN. CBZA. CILIND.
13	1651 5194	1	Elektron. Steckkarte	ELECTRONIC INSERT	CARTE DE CIRCUITS	CARTA ENCHUFABLE
14	1651 8290	8	Abstandhalter	SUPPORT	SUPPORT	SOPORTE
15	1651 8289	8	Bl.Shr.D7982-3,5x9,5	SELF-TAPPING SCREW	VIS	TORNILO CHAPA
17	1663 0908	1	Schaltplatine	SWITCH BASE	PLAQUE DISTRIBUTEUR	PLACA CONMUTADOR
18	0621 6479	13	Kabelbinder 3,6x140	CABLE BINDER	COLLIER DE CABLE	COLLAR DE CABLE
19	1663 0909	1	Litze 1,0 sw			
21	0139 7704	8	Blindstopfen PG7	BLANK PLUG	FAUX BOUCHON	TAPON CIEGO
22	0295 3408	1	Blindstopfen PG13,5	BLANK PLUG	FAUX BOUCHON	TAPON CIEGO
22.1	1663 0910	1	Blindstopfen PG9	BLANK PLUG	FAUX BOUCHON	TAPON CIEGO
23	1663 0911	1	Kabelverschr.Messing	STRICHT UNION PG 11	RACCORD DROIT	RACOR RECTO
23.1	1651 5436	1	Katelverschr.SHZ16	STRICHT UNION	RACCORD DROIT	RACOR RECTO
24	1663 0912	10	Kabelverschr.Messing	STRICHT UNION PG 7	RACCORD DROIT	RACOR RECTO
25	1663 0913	1	Ventilkabel 1	STRICHT	RACCORD	RACOR
25.1	1663 0914	1	Ventilkabel 2	STRICHT	RACCORD	RACOR
25.2	1663 0915	1	Ventilkabel 3	STRICHT	RACCORD	RACOR
25.3	1663 0916	1	Ventilkabel 4	STRICHT	RACCORD	RACOR
25.4	1663 0917	1	Ventilkabel 5	STRICHT	RACCORD	RACOR
25.5	1663 0918	1	Ventilkabel 6	STRICHT	RACCORD	RACOR
25.6	1663 0919	1	Ventilkabel 7	STRICHT	RACCORD	RACOR
25.7	1663 0920	1	Ventilkabel 8	STRICHT	RACCORD	RACOR
25.8	1663 0921	1	Ventilkabel	STRICHT	RACCORD	RACOR
35	1663 0922	1	Steckerleitg.5x1	CABLE	CABLE	CABLE
44	0621 4045	1	Signalhorn	HORN	AVERTISSEUR	BOCINA
45	0111 1179	1	Shr.M8x70 8.8A3C	HEX.BOLD	VIS 6 PANS	TORNILLO HEXAGONAL
46	0110 7163	1	Shb.9x17x1,6 A3C	WASHER	RONDELLE	ARANDELA
47	1660 6570	1	Halterohr	FIXING TUBE	TUBE DE FIXATION	TUBO DE FIGACION
50	1663 0923	1	Zeitplatine			
51	1663 0924	1	Kabel Hupe	CABLE HORN	CABLE AVERISSEUR	CABLE BOCINA

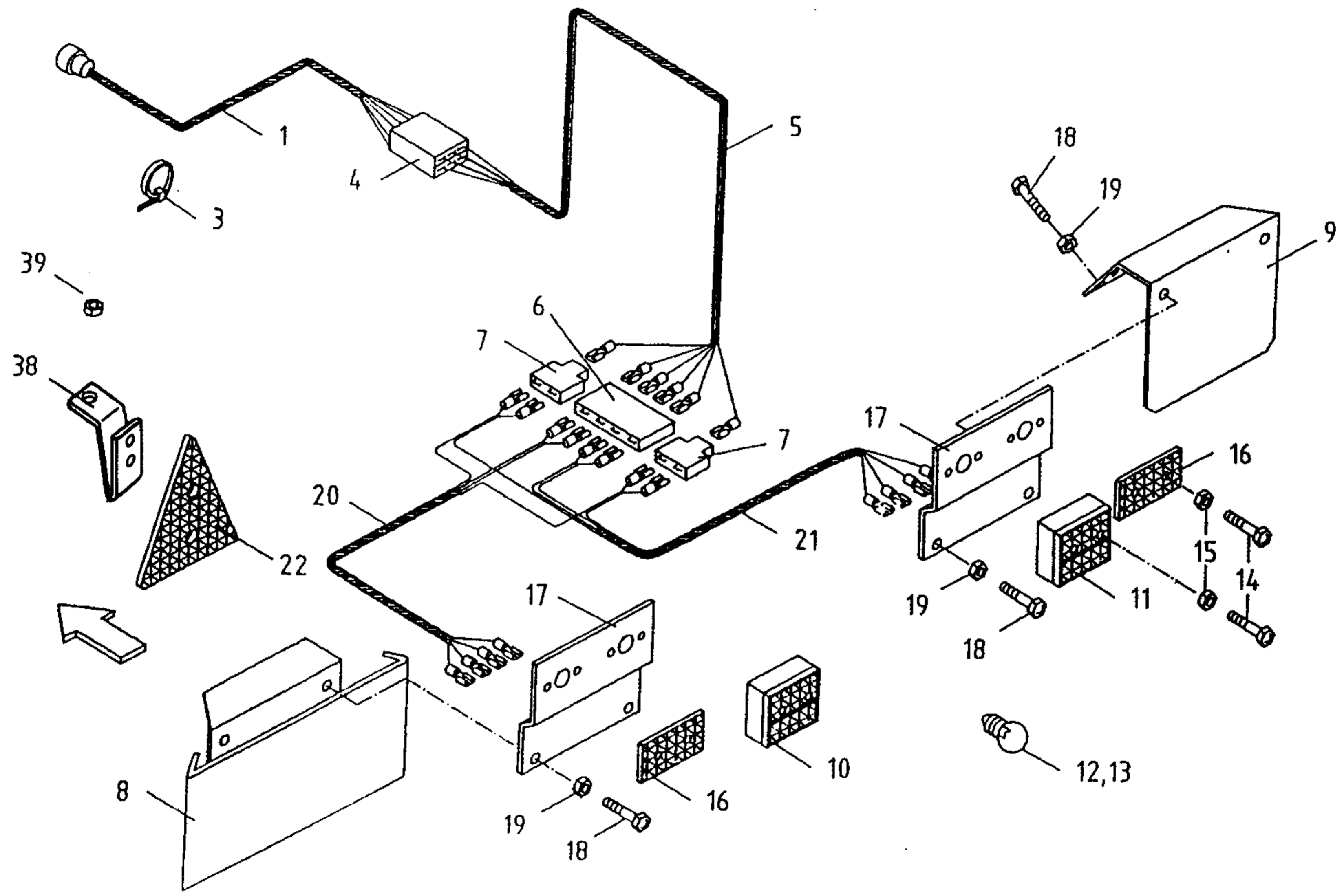

Elektrische Anlage
Beleuchtung

electr. equipment
lighting

equipem. electrique
eclairage

equipo electrico
alumbrado

Bildtafel H 07

Diagram
Diagramme
Diagrama
Bemerkung
Notes
Notes
Notas

Pos.	Teile- Nr.	Menge	Benennung	Description	Designation	Denominacion
Pos.	Part. Nr.	Qty.				
Pos.	Piece No.	Qte.				
Pos.	PiezaNo.	Cat.				
1	0657 5332	1	Elek.Leitung 11700	ELECTRIC LINES	LIGNE ELECTRIQUE	CONDUCTO ELECTRICO
3	0621 6479	15	Kabelbinder 3,6x140	CABLE BINDER	COLLIER DE CABLE	COLLAR DE CABLE
4	0621 3977	1	Steckverb. 6 polig	CABLE BINDER	COLLIER DE CABLE	COLLAR DE CABLE
5	1651 5793	1	Kabel 5200	WIRE/CABLE	CABLE	CABLE
6	0621 3975	1	Steckverh. 4 polig	CABLE BINDER	COLLIER DE CABLE	COLLAR DE CABLE
7	0621 3974	2	Leitungsverteiler			
8	1661 2580	1	Rücklichthalter	LIGHT RETAINER	SUPP FEU AR	PORTA-LAMP.TRASERA
9	1661 2578	1	Rücklichthalter re.	LIGHT RETAINER	SUPP FEU AR	PORTA-LAMP.TRASERA
10	0139 7871	1	Leuchte SBBK./li.	TAIL LIGHT	FEU ARRIERE	LUZ PILOTO/DE COLA
11	0139 7870	1	Leuchte SBBK/re.	TAIL LIGHT	FEU ARRIERE	LUZ PILOTO/DE COLA
12	0113 5950	2	Glühlampe	BULB	LAMPE	BOMBILLA
13	0110 2550	2	Glühlampe 12V/ 21W	BULB	LAMPE	BOMBILLA
14	0110 5524	8	Zyl.-Shr.AM5x12	Cheese Head Screw	VIS TETE CYLINDRI.	TORNILLO CILINDRICO
15	0620 9765	8	Mutter M5 8Á3C	LOCK NUT	ECROU DE SECURITE	TUERCA DE SEGURIDAD
16	0430 8511	2	Rücklichtstrahler	REAL REFLECTOR	CATAPHOTE	OJO DE CATO/REFLEC.
17	1651 5977	2	Rücklichthalter	LIGHT RETAINER	SUPP FEU AR	PORTA-LAMP.TRASERA
18	0110 3316	10	Shr.M6x16 8.8Á3C	HEX.HEAD SCREW	VIS TETE 6-PANS	TORN.CAB. HEXAGONAL
19	0111 4357	10	Mu.M6 8Á3C	LOCK NUT	ECROU DE SECURITE	TUERCA DE SEGURIDAD
20	1651 5789	1	Elek.Leitung 2300	ELECTRIC LINES	LIGNE ELECTRIQUE	CONDUCTO ELECTRICO
21	1651 5791	1	Elek.Leitung 800	ELECTRIC LINES	LIGNE ELECTRIQUE	CONDUCTO ELECTRICO
22	0621 4042	2	Dreieckrückstrahler	REAR-REFLECTOR	CATAPHOTE	OJO-DE-GATO
38	1663 0544	1	Halter			
39	1663 0545	1	Mutter			

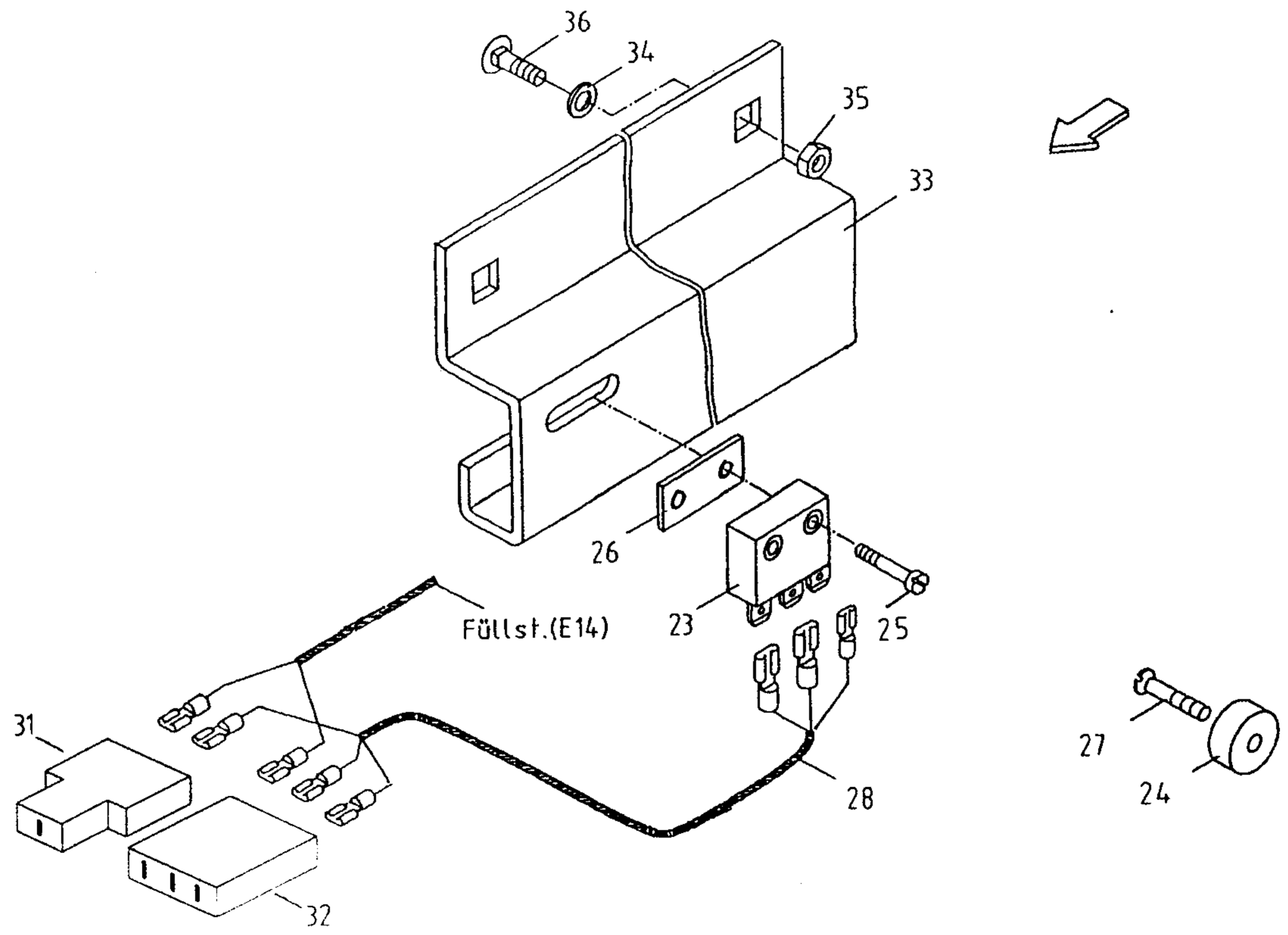

Elektrische Anlage
Rückwand

electr. equipment
rear wall

equipem. electrique
paroi arriere

equipo electrico
pared atras

Bildtafel H 09

Diagram

Diagramme

Diagrama

Bemerkung

Notes

Notes

Notas

Pos.	Teile-Nr.	Menge	Benennung	Description	Designation	Denomination
Pos.	Part. Nr.	Qty.				
Pos.	Piece No.	Qte.				
Pos.	Pieza No.	Cat.				
23	1663 0483	1	Magnetschalter	IGNITION SWITCH	COMMUT DE MAGNETO	CONMUT.ELECTR.MAGN
24	1651 2288	1	Betätigungsmagnet	MAGNET/SOLENOID	AIMANT/ELECTROMAIM.	MAGNETO /ELECTROIMA
25	0110 5515	2	Zyl.Shr.AM 4x16 D84	CHEES HEAD SCREW	VIS TETE CYLINRIQUE	TORNILLO CILINDRICO
26	1661 2389	1	Gewindestück	THREADED PIECE	PIECE FILETEE	PZA.ROSCADA
27	1661 1362	1	Shr.M5x20 D963	SCREW	VIS	TORNILLO
28	1663 0628	1	Elektr. Leitung 2300	ELECTRIC LINES	LIGNE ELECTRIQUE	CONDUCTO ELECTRICO
31	0621 3974	1	Leitungsverteiler			
32	0621 3975	1	Steckverbinder 3-polig	CABLE BINDER	COLLIER DE CABLE	COLLAR DE CABLE
33	1661 2352	1	Konsolblech	BRACKET PLATE	TOLE DE COSOLE	CHAPA CONSOLA
34	0621 4192	2	Scheibe 8,4x25x3 A3C	WASHER	RONDELLE	ARANDELLA
35	0110 4944	2	Sich.Mu.M8 8A3C	LOCK NUT	ECROU DE SECURITE	TUERCA DE SEGURIDAD
36	0620 7535	2	Shr.M8x16 8.8 A3C	OVAL HEADED BOLT	VIS TETE DEMI RONDE	TORNILLO CAB.BOMB

K 01

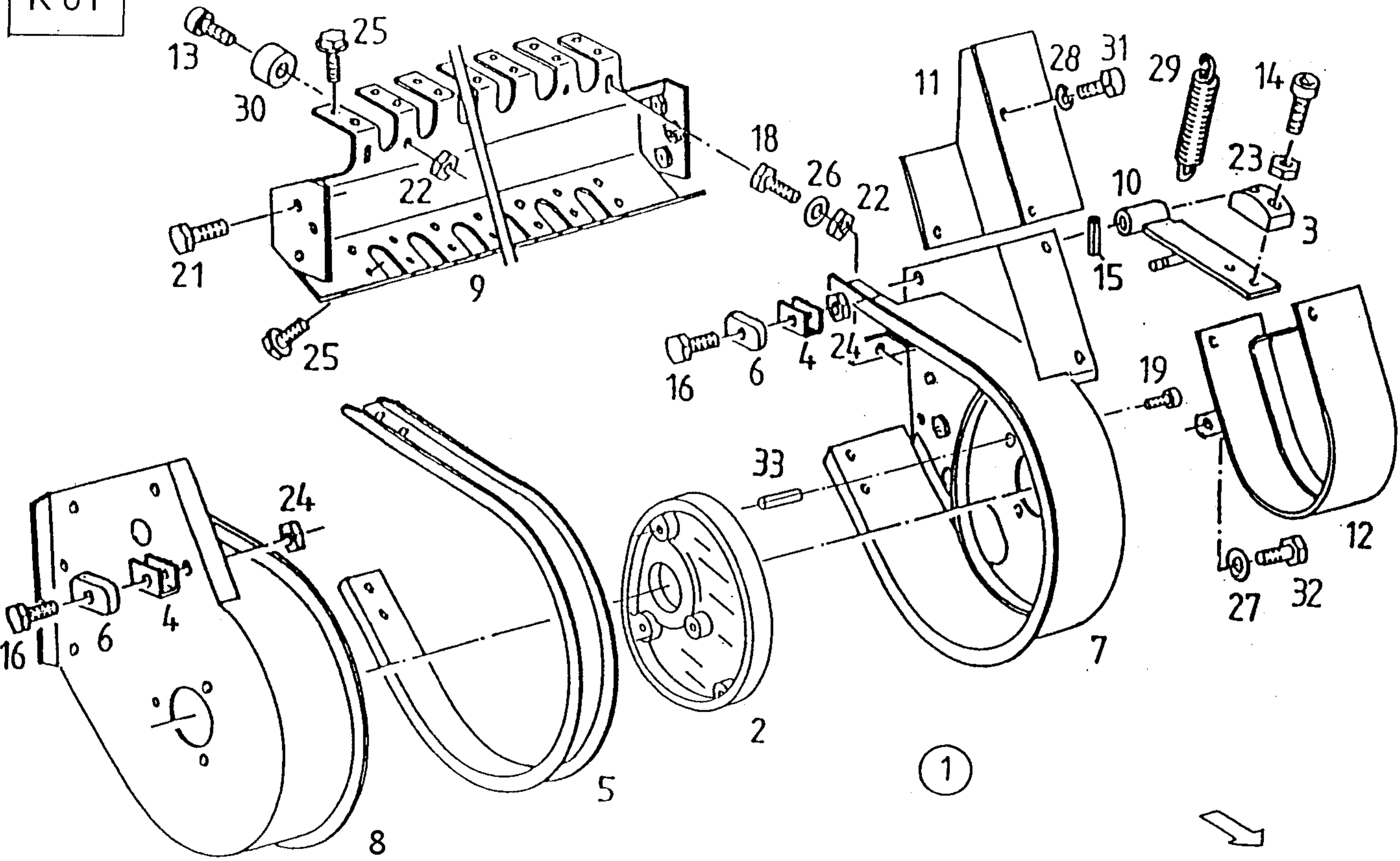

Pos.	Teile- Nr.	Menge	Benennung	Description	Designation	Denomination
Pos.	Part.Nr.	Qty.				
Pos.	Piece No.	Qte.				
Pos.	Pieza No.	Cat.				
			Pick-Up	pick-up	pick-up	pick-up
			Abstreifer	scraper	racleur	raspador
1	1663 0125	1	Pick-Up mont.5 Hasp.	Pick-up	pick-up	pick-up
2	0629 6264	1	Steuerkurve innen	STEERING PLATE	GUIDE	GUIA
3	0657 1134	1	KETTENSPANNKLOTZ PA6	TENSION-BLOCK	BLOC TENDEUR	BLOQUE TENSOR
4	0657 1322	3	Bügel	YOKE	ETRIER	ESTRIBO
5	1663 0114	25	Streifblech	sheet	tole	chapa
6	0657 1323	6	Anschlag	STOP	BUTEE	TOPE
7	1663 0115	1	Seitenteil li.gsw.	side member left	piece laterale gau.	pieza lateral izqui
8	1663 0119	1	Seitenteil re.gsw.	side member right	piece laterale dro.	pieza lateral dere.
9	1663 0112	1	Streifblechträger	support	support	soporte
10	0655 9221	1	KETTENSPANNER VORM.	TENSIONER	TENDEUR DE CRAINE	TENSOR CADENA
11	0657 1099	1	Schutzblech	GUARD PLATE	TOLE DE GARDE	CHAPA PROTECTORA
12	0657 1090	1	Kettenschutz geschw.	CHAIN/TRACK GUARD	GARDE-CHAINE	PROTECC.CADENA
13	0110 5544	2	ZYL.SCHRAUBE AM 6x20	CYLINDRICAL SCREW	VIS CYLINDRIQUE	TORNILLO CILINDRICA
14	0111 0577	2	Shr. M 8x25 D912 8.8	SCREW	VIS	TORNILLO
15	0111 5441	1	Spannstift 5x32 DIN	DOWEL PIN	GOUPILLE SERRAGE	PERNO FIADOR
16	0111 1288	3	Shr.M10x40 D931	HEX. HEAD SCREW	VIS TETE 6-PANS	TORN. HEX.
18	0111 2254	2	Shr.M 6x20 DIN 933	HEX. HEAD SCREW	VIS TETE 6-PANS	TORN.CAB. HEXAGONAL
19	0620 9476	2	Shr.H2091 D933 M8x30	HEX.HEAD SCREW	VIS TETE 6-PANS	TORN.CAB.HEXAGONAL
21	0111 2418	6	Shr. M 10x25 88A3C	HEX. HEAD SCREW	VIS TETE 6-PANS	TORN.CAB. HEXAGONAL
22	0111 4357	4	Mu. M6 8A3C	LOCK NUT	ECROU DE SECURITE	TUERCA DE SEGURIDAD
23	0110 4944	2	Sich. Mu. M8 8A3C	LOCK NUT	ECROU DE SECURITE	TUERCA DE SEGURIDAD
24	0620 9768	9	Sich. Mu. M10 A3C	LOCK NUT	ECROU DE SECURITE	TUERCA DE SEGURIDAD
25	0627 3854	106	Ripp-Schraube	HEX. HEAD SCREW	VIS TETE 6-PANS	TORNILLO HEX.
26	0621 4189	4	Scheibe 6,4x18x2	WASHER	RONDELLE	ARANDELA
27	0110 7163	1	Scheibe 9x7x1,6 A3.C	WASHER	RONDELLE	ARANDELA
28	0110 2799	3	Federring A8 DIN 123	SPRING WASHER	RONDELLE ELASTIQUE	ARANDELA ELASTICA
29	0621 5561	1	Zugfeder	TENSION SPRING	RESSORT DE RAPPEL	RESORTE DE TENSION
30	0657 1355	2	Gummipuffer	RUBBER BLOCK	BLOC AMORTISSEUR	BLOQUE DE GOMA
31	0111 2322	3	Shr. M 8x20 8.8 A3C	HEX. HEAD SCREW	VIS TETE 6-PANS	TORN.CAB. HEXAGONAL
32	0111 2307	1	Shr. M 8x16 88A3C	HEX. HEAD SCREW	VIS TETE 6-PANS	TORN.CAB. HEXAGONAL
33	1661 4668	1	Spannstift 10x11	dowel pin	goupille serrage	perno fiador

Bildtafel K01

Diagram
Diagramme
Diagrama
Bemerkungen
Notes
Notes
Notas

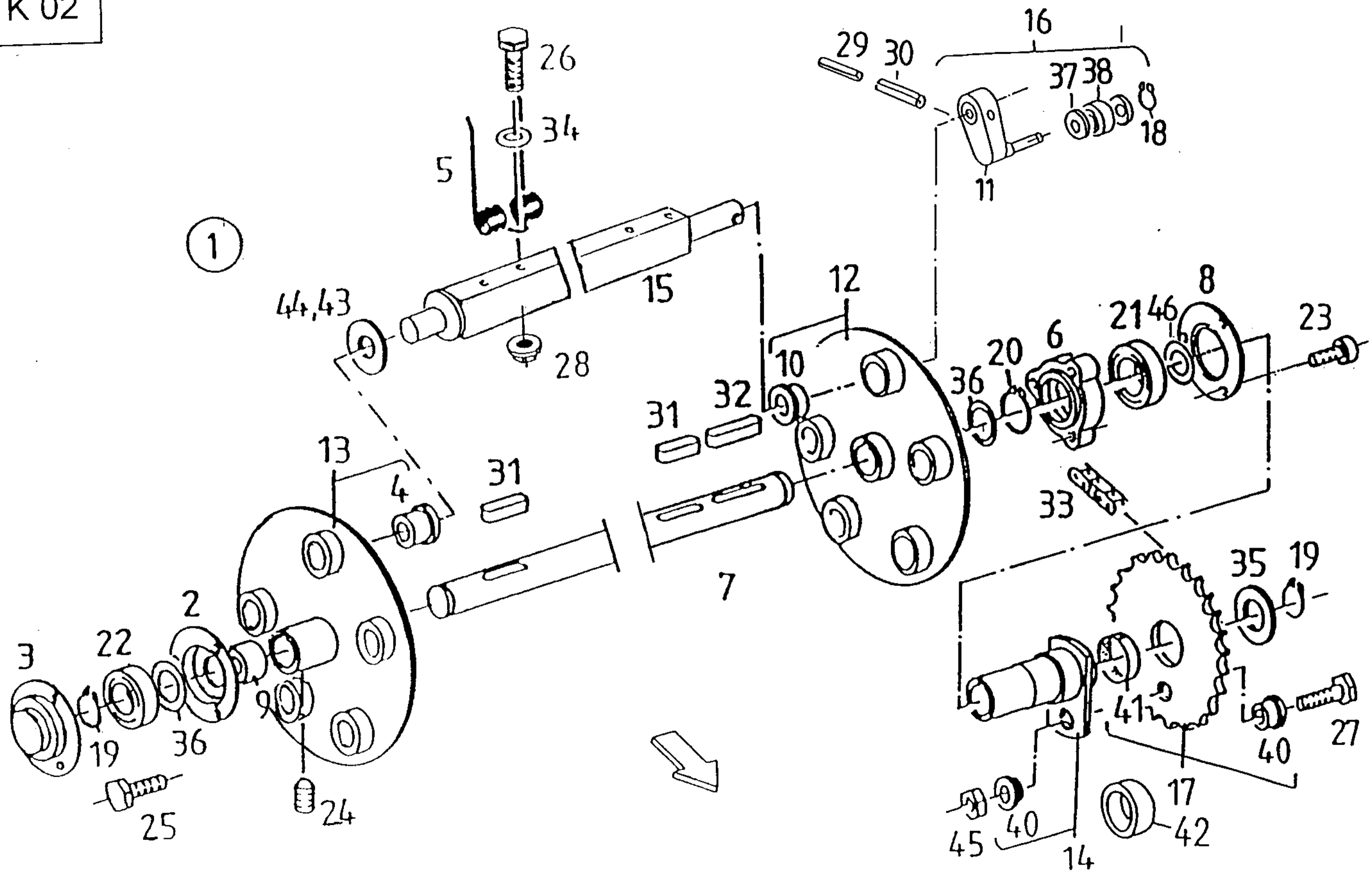

Pos.	Teile-Nr.	Menge	Pick - Up	pick-up	pick-up	pick-up	Bildtafel K02
Pos.	Part.Nr.	Qty.	Trommel	rum	tambour	tambor	Diagram
Pos.	Piece No.	Qte.	Benennung	Description	Designation	Denomination	Diagramme
Pos.	Pieza No.	Cat.					Bemerkungen
1	1663 0125	1	Pick-Up mont.5 Hasp.	Pick-up	Pick-up	pick-up	
2	0628 2196	1	Lagerschale innen	TERMINAL RING	RONDELLE	ARANDELA	
3	0630 1830	1	Lagerschale AUSSEN	TERMINAL RING	RONDELLE	ARANDELA	
4	0624 6795	5	Buchse T25x32x23	BUSH	MANCHON	MANGUITO	
5	0629 6285	65	Haspelfeder	REEL TINE	DENT	DEDO	
6	0657 7397	1	Flansch	FLANGE	BRIDE	BRIDA	
7	0657 1004	1	Antriebswelle grund.	DRIVE SHAFT	ARBRE DE COMMANDE	EJE MOTRIZ	
8	0657 7406	1	ABDECKSCHEIBE	COVER	COUVERCLE	TAPA,	
9	0657 7407	1	Distanzring	SPACER RING	BAGUE ENTRETOISE	ANILLO DISTANCIADOR	
10	0657 1309	5	Buchse	BUSH	MANCHON	MANGUITO	
11	0657 1321	5	Laufbolzen	PIN	AXE	PERNO	
12	1651 3298	1	Rosette li.m.Buchsen	ROSETTE	ROSACE	ROSETA	
13	1651 3299	1	Rosette re.m.Buchsen	ROSETTE	ROSACE	ROSETA	
14	0655 9244	1	Flanschnabe m.Buchse	FLANGED HUB	MOYEU A BRIDE	CUBO BRIDA	
15	1661 3400	5	Haspelchr gsw.	tube	tube	tubo	
16	1661 5203	5	Steuerarm vorm.	control arm	bras de commande	brazo de mando	
17	1663 0155	1	Kettenrad mont. 34 Z	chain sprocket	pignon a chaine	non ae cadena	
18	0110 7726	5	Sich.Ring 17x1	CIRCLIP	CIRCLIP	ANILLO DE SEGURIDAD	
19	0110 7742	2	Sich.Ring 30x1,5	CIRCLIP	CIRCLIP	ANILLO DE SEGURIDAD	
20	0110 7760	1	Sich.Ring 45x1,75	CIRCLIP	CIRCLIP	ANILLO DE SEGURIDAD	
21	0110 8982	1	RI-LAGER 6009 -2RS	GR.BALL BEARING	ROULEM.R.A BILLES	COJ.DE BOLAS RAN.	
22	0110 6763	1	Rillenkugellager	GR. BALL BEARING	ROULEM.R.A BILLES	COJ.DE BOLAS RAN.	
23	0110 3340	3	SHR.H2091 D912 M8x50	hex. head screw	vis tete 6-pans	torn. cab. hexagonal	
24	0110 8913	2	Gew-St. M10x12 D914	THREADED PIN	COUJON FILE E	ESPIGA ROSCADA	
25	0110 3381	3	Shr. M8x20 D933 3.8	HEX. HEAD SCREW	VIS TETE 6-PANS	TORN.CAB.HEXAGONAL	
26	0110 1184	65	SHR.M8x75 D931 88A3C	HEZ.BOLT	VIS 6 PANS	TORNILLO HEXAGONAL	
27	0110 2356	1	Shr. M 8x40 88A3C	BOLT	VIS	TORNILLO	
28	0110 7863	65	MU.M8 D6926 8A3C	HEX. NUT	ECROU 6 PANS	TUERCA HEXAGONAL	
29	0110 7348	5	Spannstift 6x165 DIN	DOWEL PIN	GOUPILLE SERRAGE	PERNO FIADOR	
30	0110 7382	5	Spannstift 10x65	DOWEL PIN	GOUPILLE SERRAGE	PERNO FIADOR.	
31	0110 2126	2	Passfeder A 8x7x45	FITTING KEY	CLAVETTE D'AJUSTAGE	CHAVETA DE AJUSTE	
32	0110 2435	1	Passfeder A 8x7x80	FITTING KEY	CLAVETTE D'AJUSTAGE	CHAVETA DE AJUSTE	
33	0110 0139	1	Kette 19,05-1x87E	chain	chaine	cadena	
34	0110 8374	65	Scheibe 8,4 A3C	WASHER	RONDELLE	ARANDELA	
35	0621 4490	1	Schb.31,0x55,0x4,0	DISC	DISQUE	disco	
36	0113 8686	0	Pass-Schb. 30x42x0,5	spacer	RONDELLE D'EPaisseur	ARANDELA DE ESPESOR	
37	0621 4938	10	NILOSRING 6303 ZAV	NILOS-RING	BAGUE-HILOS	ANILLO-HILOS	
38	0621 5027	5	Laufrolle 1	ROLLER	GALET	RODILLO	
40	0657 1314	2	Scherbuchse	BUSH	MANCHON	MANGUITO	
41	0627 7516	1	BUCHSE	BEARING BUSH	MANCHON	MANGUITO	
42	0657 1148	1	ROHRSTUECK	PIPE/TUBE	BOUT DE TUYAU	PZA.TUBO	
43	0621 4314	4	SCHB.26,0x1,0	WASHER	RONDELLE	ARANDELA '	
44	0621 4313	4	Scheibe 26x38x2	WASHER	RONDELLE	ARANDELA	
45	0110 4944	5	Sich. Mu.M8 8A3C	LOCK NUT	ECROU DE SECURITE	TUERCA DE SEGURIDAD	

Bildtafel K02
Diagram
Diagramme
Bemerkungen
Notes
Notes
Notas

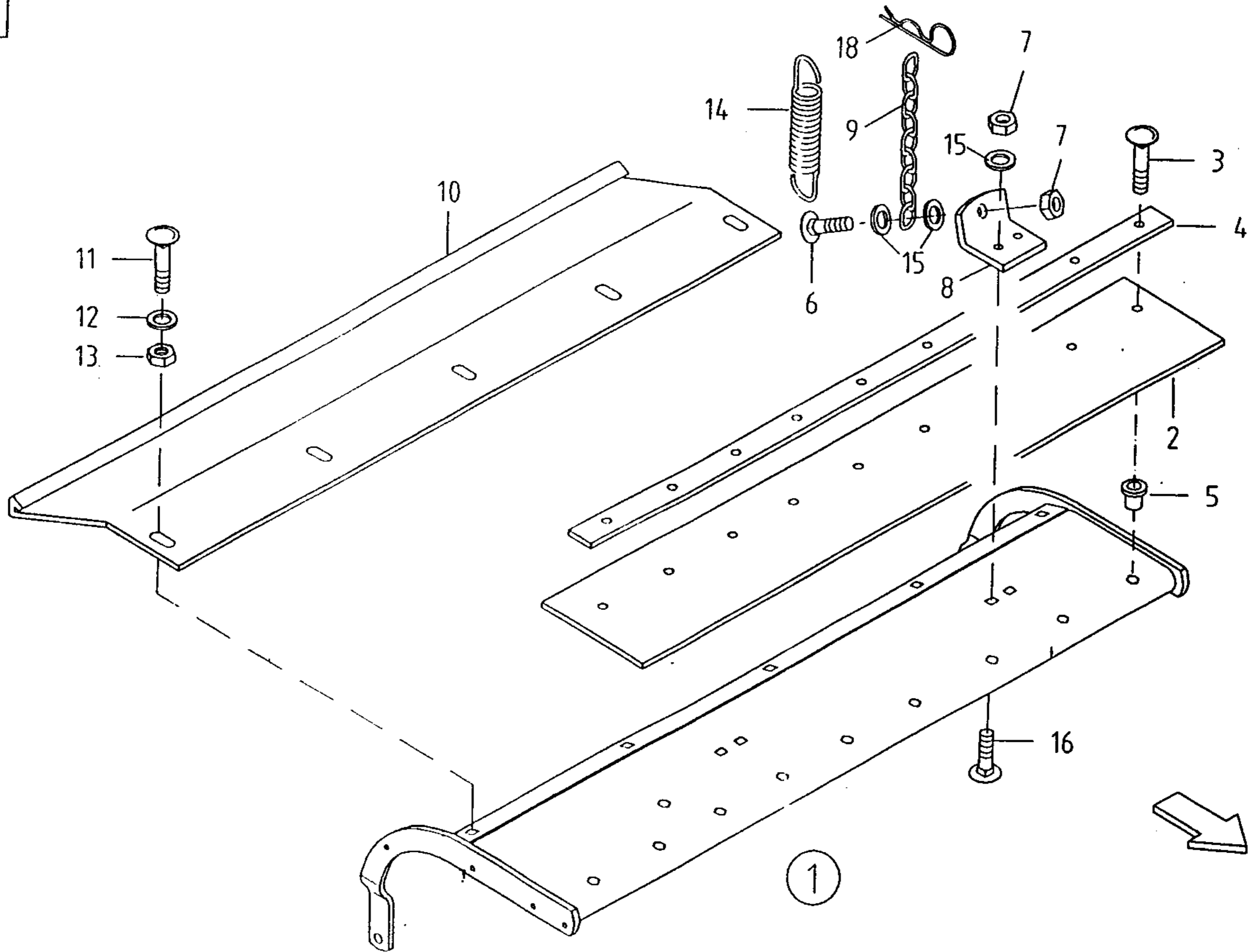

Pos.	Teile- Nr.	Menge	Benennung	Description	Designation	Denomination
Pos.	Part. Nr.	Qty.				
Pos.	Piece No.	Qte.				
Pos.	Pieza No.	Cat.				
			Pick-Up Prallblech	pick-up baffle-plate	pick-up tole-chicane	pick-up chapa de choque
1	1661 1487	1	Prallblech mont.	Baffle-plate	tole-chicane	chapa de choque
2	1661 1479	1	GUMMILEISTE	rubber bar	barrette caoutch.	lion de goma
3	0114 2806	9	FLRD.SHR.M6x25	TRUSS-HEAD SCREW	VIS TETE BOMBEE	TORN.CAB.SEMIRED.
4	0657 8934	1	LEISTE	STRIP	LISTEAU/MOULURE	LISTON
5	0114 2805	9	Blindnietmutter M6	RIVET NUT	ECROU BORGNE A RIV	TUERCA FIJ.REMACHE
6	0113 7628	2	Shr. M 8x30 DIN 603	SAUCER HEAD SCREW	VIS A TETE BOMBEE	TORN. CAB. BOMBEADA
7	0110 4944	4	Sich. Mu. M8 8A3C	LOCK NUT	ECROU DE SECURITE	TUERCA DE SEGURIDAD
8	1651 3473	2	HALTER	RETAINER	SUPPORT/PORTEQUTIL	SOPORTE
9	0139 7609	2	Kette 6x42 D763-16GL	CHAIN/TRACK	CHAINE/CHENILLE	CADENA
10	0657 7423	1	VERLÄNGERUNG	EXTENSION	RALLONGE	EXTENSION
11	0620 7535	5	Shr.M 8x 16 8.8 A3C	OVAL HEADED BOLT	VIS TETE DEMI RONDE	TORNILLO CAB.BOMB
12	0110 7165	5	Scheibe 11,0 A3C	WASHER	RONDELLE	ARANDELA
13	0110 4944	4	Sich. Mu. M8 8A3C	LOCK NUT	ECROU DE SECURITE	TUERCA DE SEGURIDAD
14	0139 7931	2	Z.Feder 3,5x18,5x173	DRAW SPRING	RESSORT TRACTION	RESORTE TRACTION
15	0112 7538	4	Shb. 10,5 DIN 7349	WASHER	RONDELLE	ARANDELA
16	0110 8524	4	SHR. M8x20 D603	SCREW	vis	TORNILLO
18	0621 5666	2	Federstecker 3 A3C	SPRING CLIP	AGRAFE	PASADOR

Bildtafel K03

Diagram
Diagramme
Diagrama
Bemerkungen
Notes
Notes
Notas

K 04

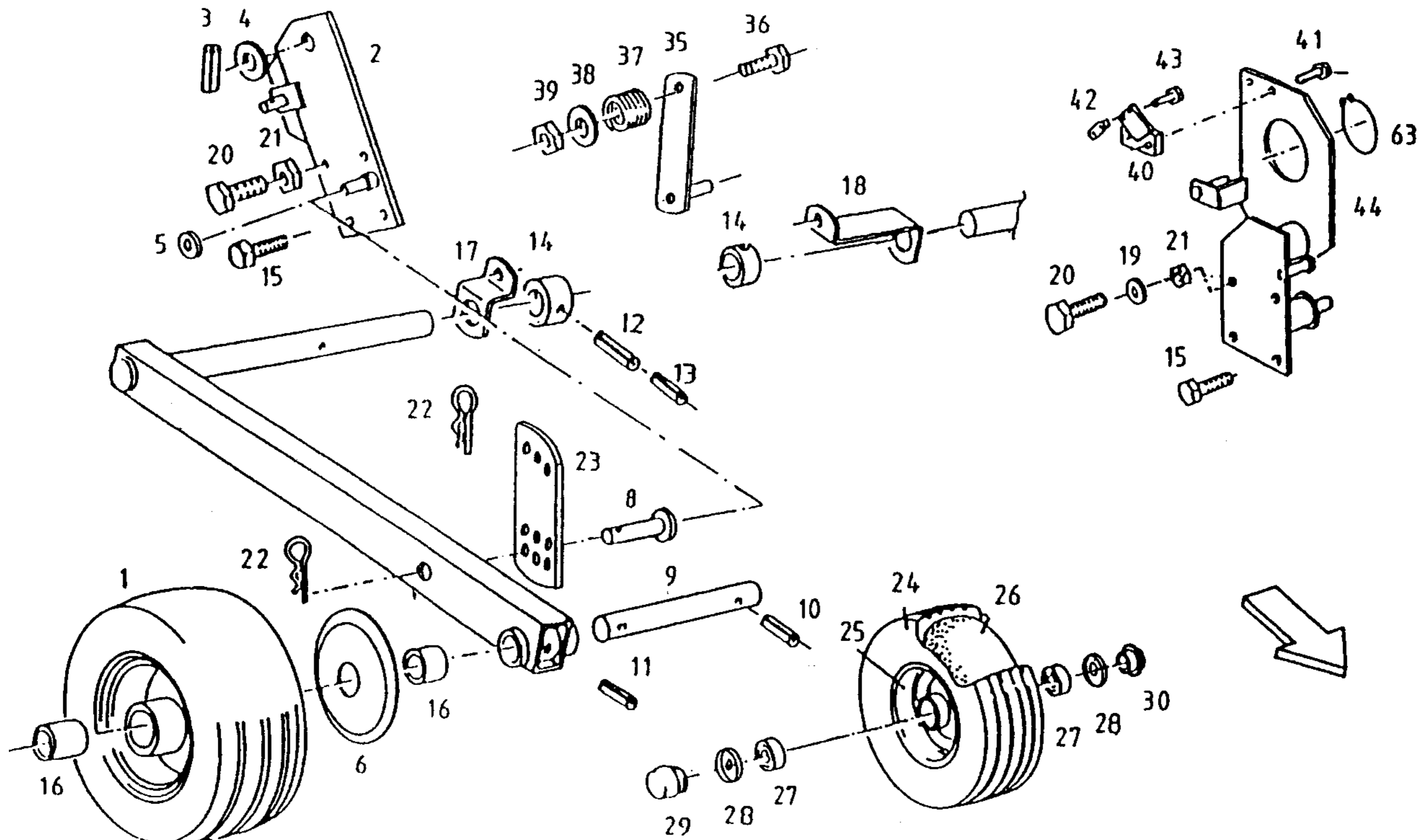

Pick up Tastrad
Luftrad

pu-contact roller
pneumatic tired

pu-roulette
sur pneus

pu-rodillo
neumatico

Bildtafel K04

Diagram
Diagramme
Diagrama
Bemerkungen
Notes
Notas

Pos.	Teile-Nr.	Menge	Benennung	Description	Designation	Denomination
Pos.	Part.Nr.	Qty.				
Pos.	Piece No.	Qte.				
Pos.	Pieza No.	Cat.				
1	0656 4733	2	Rad 15x6,00-6 silber	WHEEL	ROUE	RUEDAOERE
2	1663 0109	1	Pu-Halter re. gsw.	retainer	support	soporte
3	0111 5460	1	Spannstift 6x45 DIN	COLLET CHUCK	DOUILLE	PASADOR
4	0621 4234	1	Scheibe 31x45x2,0	WASHER	RONDELLE	ARANDELA
5	0621 4226	1	Schb. 21,0 D125 A3C	WASHER	RONDELLE	ARANDELA
6	0656 4747	2	Abdeckscheibe silber	COVERING DISC	COUVERCLE	TAPA
7	1651 7499	2	Lenker gsw.	AXLE LINK	BRAS DE SUSPENSION	ELEMENTO GUIA
8	0621 0033	2	Blz.16x62x57 D1434	PIN	AXE	PERNO
9	1651 4201	2	Bolzen	PIN/BOLT/STUD	BOULON/AXE	BULON
10	0111 5457	2	Spannstift 6x36 DIN	DOWEL PIN	GOUPILLE	PASADOR
11	0115 7344	2	Spannstift 6x40 DIN	DOWEL PIN	GOUPILLE SERRAGE	PERNO FIADOR
12	0112 3863	2	Spannstift 8x60 DIN	Dowel Pin	goupille serrage	perno fiador
13	0115 7338	2	Spannstift 5x60 PIN	DOWEL PIN	GOUPILLE SERRAGE	PERNO FIADOR
14	0657 7422	2	Ring	RING	BAGUE	ANILLO
15	0117 3914	4	Shr. M 10x25 8.8A3C	HEX.BOLT	VIS 6 PANS	TORNILLO HEXAGONAL
16	0657 6830	2	Rohr	PIPE	TUBE	TUBO
17	0657 7421	1	Tastradhalter re.	SUPPORT	SUPPORT	SOPORTE
18	0657 7420	1	Tastradhalter	SUPPORT	SUPPORT	SOPORTE
19	0112 7538	2	Shb. 10,5 DIN 7349	WASHER	RONDELLE	ARANDELA
20	0111 2429	4	Shr. M 10x30 88A3C	HEX. HEAD SCREW	VIS TETE 6-PANS	TORN CAB HEXAGONAL
21	0620 9768	4	Sich. Mu. M10 A3C	LOCK NUT	ECROU DE SECURITE	TUERCA DE SEGURIDAD
22	0621 5666	4	Federstecker 3 A3C	SPRING CLIP	AGRAFE	PASADOR
23	0655 6744	2	LENKER	ARM	BRAS	BRAZO
24	0114 1364	2	Reifen 15x6,00-6 6PR	TYRE	ENVELOPPE	NEUMATICO
25	0656 4735	2	Felge 4.50 Ax6 silb.	RIM	JANTE	LLANTA
26	0114 1365	2	SCHLAUCH 15X6,00X6	TUBE	CHAMBRE A AIR	CAMARA DE AIRE
27	0112 4703	4	Ri-La er 6205 - RS	BEARING	COUSSINET	COJINETE
28	0116 7577	4	NILOSRING 6205ZAV	SEAL RING	ANNEAU	ANILLO NILOS
29	0658 0546	2	Schutzkappe D 52	CAP	CHAPEAU	CAPERUZA
30	0656 7492	2	Dichtungsstück	GASKET	JOINT	JUNTA
35	1663 0536	1	HEBEL GESCHW.	LEVER	LEVIER	PALANCA
36	0111 1298	1	Shr.M10x45D931 88A3C	HEX. HEAD SCREW	VIS TETE 6-PANS	TORN. CAB. HEXAGONAL
37	0621 5308	1	D.FED. 2,0/ 16,0/	COMPRESSION SPRING	RESSORT DE COMPR	RESORTE PRESION
38	0110 7165	1	Schb. 11 A3C D126	WASHER	RONDELLE	ARANDELA
39	0620 9768	1	Sich. Mu. M1 0 A3C	LOCK NUT	ECROU DE SECURITE	TUERCA DE SEGURIDAD
40	0657 7387	1	Ausrücker geschweißt	GRAPHITE RING	BAGUE GRAPHITEE	ANILLO DE GRAFITO
41	0627 7504	2	Shr.M12x30 DIN 933	HEX. HEAD SCREW	VIS TETE 6-PANS	TORNILLO HEX.
42	0658 7560	1	GLEITSTÜCK	SLIDE PIECE	PIECE COULISSANTE	PIEZA CORREDIZA
43	0111 2333	2	Shr. M 8x25 88A3C	HEX. HEAD SCREW	VIS TETE 6-PANS	TORN.CAB. HEXAGONAL
44	1663 0106	1	Halter li. gsw.	retainer left	support a gauche	soporte izquierda
63	0110 7792	1	Sich.Ring 105x4	CIRCLIP	CILIP	ANILLO SEGURIDAD

K 06

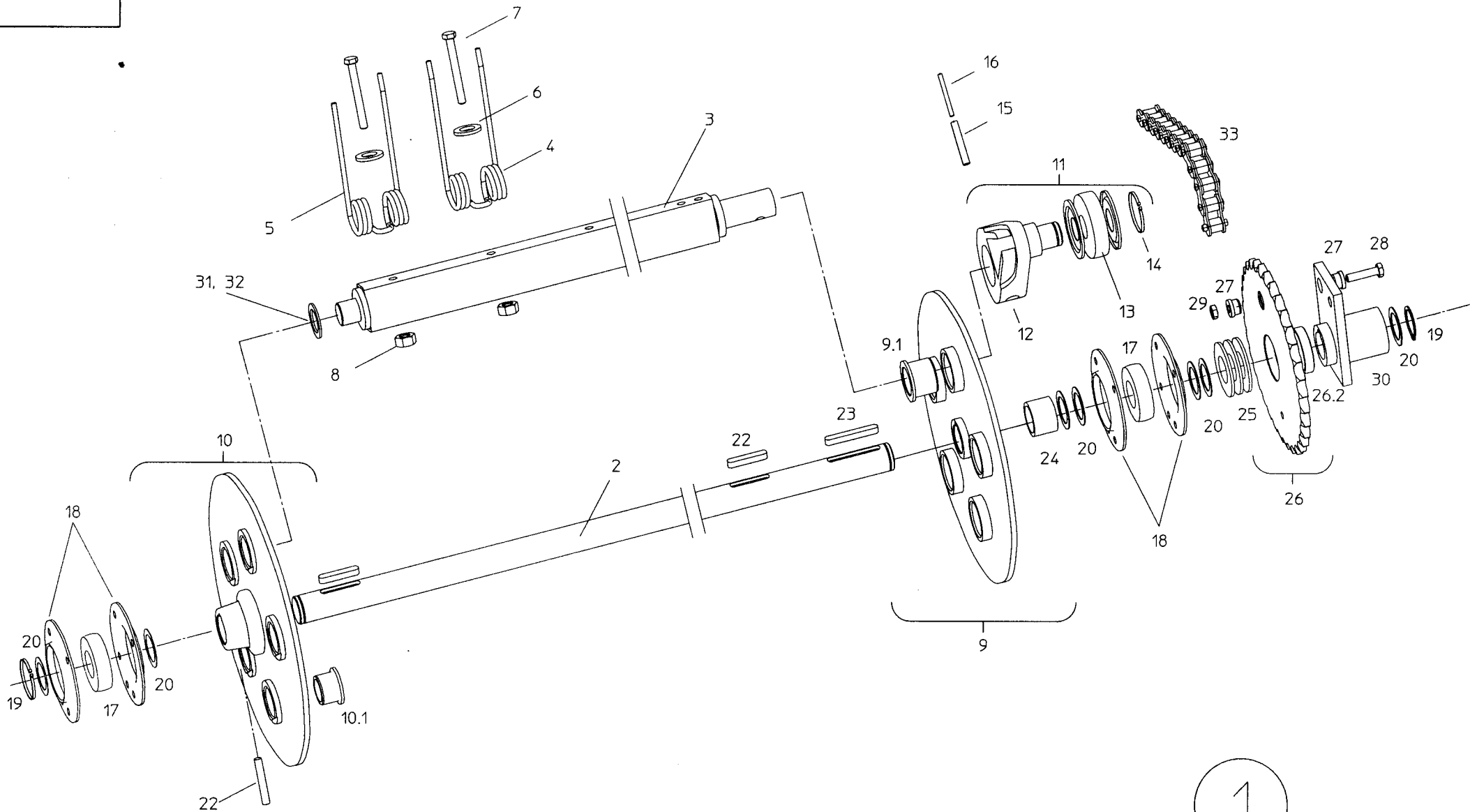

1

Bildtafel K06

			Pick -Up 1.8 Trommel	pick-up 1.8 rum	Pick-up 1.8 tambour	Pick-up 1.8 tambor	Diagram
							Di agramme
Pos.	Teile-Nr.	Menge	Benennung	Description	Designation	Denominacion	Diagrama
Pos.	Part.Nr.	Qty.					Bemerkungen
Pos.	Piece No.	Qte.					Notes
Pos.	Pieza No.	Cat.					Notes
							Notas
1	1663 0740	1	Pick-Up 1.8 mont.	Pick-up 1.8	Pick-up 1.8	Pick-up 1.8	
2	1663 0685	1	Antriebswelle	DRIVE SHAFT	ARBRE DE COMMANDE	EJE MOTRIZ	
3	1663 0682	5	Haspelrohr gsw.	tube	tube	tubo	
4	0629 6285	65	Haspelfeder	REEL TINE	DENT	DEDO	
5	1663 0684	5	Haspelfeder	REEL TINE	DENT	DEDO	
6	0113 8374	70	Scheibe 8,4 A3C	Washer	Rondelle	Arandela	
7	0111 1184	70	Shr.M8x75 D931 88A3C	HEX.BOLT	VIS 6 PANS	TORNILLO HEXAGONAL	
8	0139 7863	70	Mu.M8 D6926 8A3C	HEX.NUT	ECROU 6 PANS	TUERCA HEXAGONAL	
9	1651 3298	1	Rosette li.m.Buchsen	ROSETTE	ROSACE	ROSETA	
9.1	0657 1309	5	Buchse	BUSH	MANCHON	MANGUITO	
10	1651 3299	1	Rosette re.m.Buchsen	ROSETTE	ROSACE	ROSETA	
10.1	0624 6795	5	Buchse	BUSH	MANCHON	MANGUITO	
11	1661 5203	5	Steuerarm vormont.	control arm	bras de commande	brazo de mando	
12	1661 5205	5	Steuerhebel				
13	0621 5027	5	Laufrolle				
14	0110 7726	5	Sich.Ring 17x1	CIRCLIP	CIRCLIP	ANILLO DE SEGURIDAD	
15	0115 7382	5	Spannstift 10x65	DOWEL PIN	GOUPILLE SERRAGE	PERNO FIADOR	
16	0115 7348	5	Spannstift 6x65	DOWEL PIN	GOUPILLE SERRAGE	PERNO FIADOR	
17	1663 0709	2	Y-Lager	GR.BALL BEARING	ROULEM.R.A BILLES	COJ.DE BOLAS RAN.	
18	1663 0686	2	Blechgehäuse 2-teilig				
19	0110 7742	2	Sich.Ring 30x1,5	CIRCLIP	CIRCLIP	ANILLO DE SEGURIDAD	
20	0621 4481	10	Paßscheibe 30x42xl	spacer	RONDELLE D'EPAISSEUR	ARANDELA DE ESPESOR	
21	0620 8913	2	Gewindestift				
22	0621 2416	2	Paßfeder A8x7x45	FITTING KEY	CLAVETTE D'AJUSTAGE	CHAVETA DE AJUSTE	
23	1663 0743	1	Paßfeder A8x7x60	FITTING KEY	CLAVETTE D'AJUSTAGE	CHAVETA DE AJUSTE	
24	1663 0766	1	Distanzring	SPACER RING	BAGUE ENTRETOISE	ANILLO DISTANCIADOR	
25	0621 4420	3	Scheibe 31x56x4	DISC	DISQUE	disco	
26	1663 0155	1	Kettenrad mont.Z34	chain sprocket	pignon a chaine	non ae cadena	6R
26.1	0657 7432	1	Kettenrad mont.Z32	chain sprocket	pignon a chaine	non ae cadena	4R
26.2	0627 7516	1	Buchse	BUSH	MANCHON	MANGUITO	
27	0657 1314	2	Scherbuchse	BUSH	MANCHON	MANGUITO	
28	0111 1136	1	Shr.M8x35 A3C	HEX.BOLT	VIS 6 PANS	TORNILLO HEXAGONAL	
29	0110 4944	1	Sich.Mu.M8 A3C	LOCK NUT	ECROU DE SECURITE	TUERCA DE SEGURIDAD	
30	1661 0744	1	Flanschnabe m.Buchse	FLANGED HUB	MOYEU A BRIDE	CUBO BRIDA	
31	0621 4314	5	Scheibe 26x38xl	DISC	DISQUE	disco	
32	0621 4313	5	Scheibe 26x38x2	DISC	DISQUE	disco	
33	1663 0768	1	Kette 19,05 1x90E	chain	chaîne	cadena	6R
33.1	1663 0767	1	Kette 19,05 1x89L	chain	chaîne	cadena	4R
40	0657 1314	2	Scherbuchse	BUSH	MANCHON	MANGUITO	
41	0627 7516	1	BUCHSE	BEARING BUSH	MANCHON	MANGUITO	
42	0657 1148	1	ROHRSTUECK	PIPE/TUBE	BOUT DE TUYAU	PZA.TUBO	
43	0621 4314	5	SCHB.26,Ox38,Ox1,0	WASHER	RONDELLE	ARANDELA	
44	0621 4313	5	Scheibe 26x38x2	WASHER	RONDELLE	ARANDELA	
45	0110 4944	5	Sich. Mu.M8 8A3C	LOCK NUT	ECROU DE SECURITE	TUERCA DE SEGURIDAD	

K 07

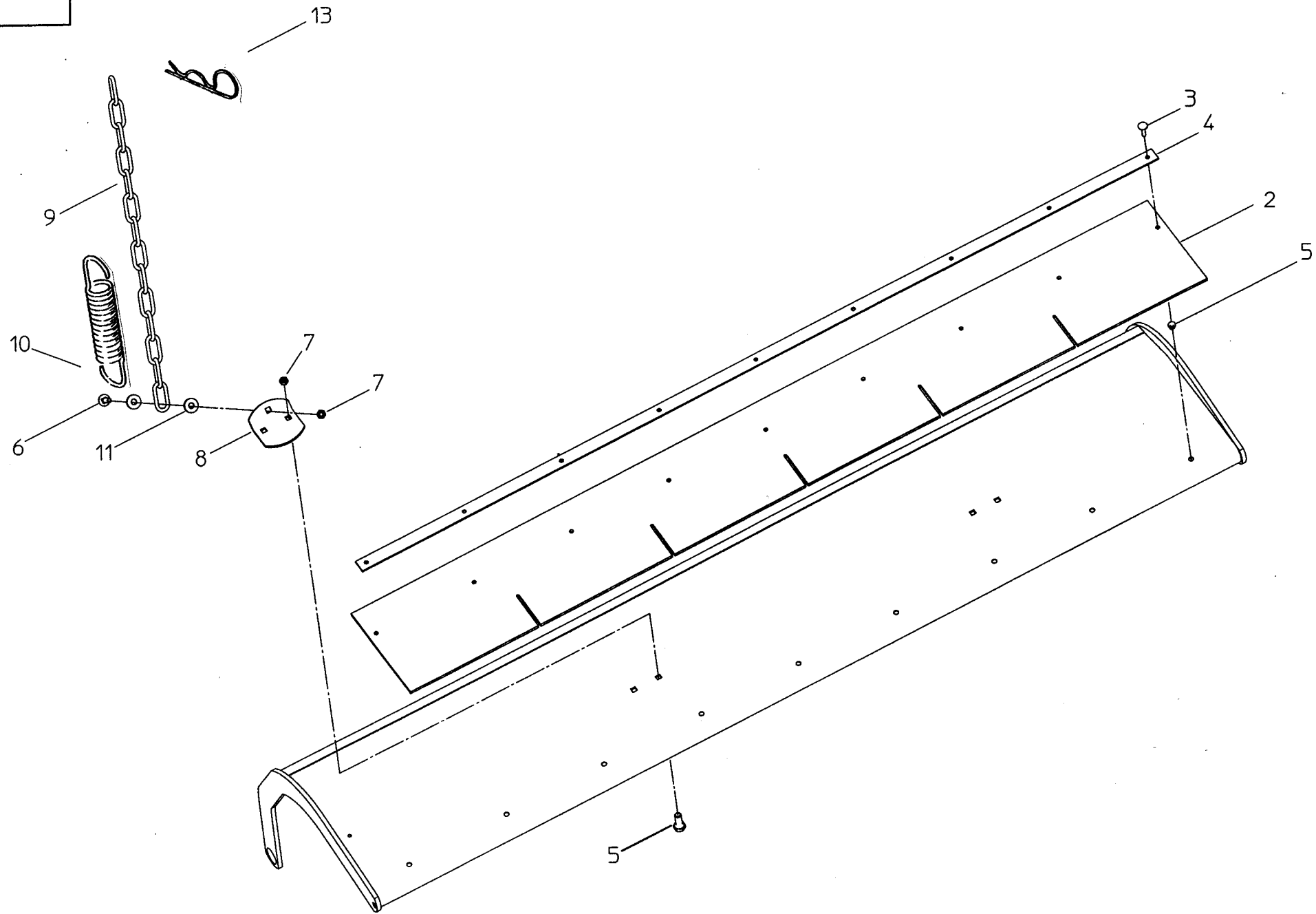

Bildtafel K07

Diagram

Diagramme

Diagrama

Bemerkungen

Notes

Notes

Notas

			Pick-Up 1.8 Prallblech	Pick-up 1.8 baffle-plate	Pick-up 1.8 tole-chicane	Pick-up 1.8 chapa de choque	
Pos.	Teile-Nr.	Menge	Benennung	Description	Designation	Denominacion	
Pos.	Part.Nr.	Qty.					
Pos.	Piece No.	Qte.					
Pos.	Pieza No.	Cat.					
1	1663 0730	1	Prallblech geschweißt	Baffle-plate	tole-chicane	chapa de choque	
2	1661 1479	1	GUMMILEISTE	rubber bar	barrette caoutch.	lion de goma	
3	0114 2806	9	FLRD.SHR.M6x25	TRUSS-HEAD SCREW	VIS TETE BOMBEE	TORN.CAB.SEMIRED.	
4	0657 8934	1	LEISTE	STRIP	LISTEAU/MOULURE	LISTON	
5	0114 2805	9	Blindnietmutter M6	RIVET NUT	ECROU BORGNE A RIV	TUERCA FIJ.REMACHE	
6	0113 7628	2	Shr. M 8x30 DIN 603	SAUCER HEAD SCREW	VIS A TETE BOMBEE	TORN. CAB. BOMBEADA	
7	0110 4944	6	Sich. Mu. M8 8A3C	LOCK NUT	ECROU DE SECURITE	TUERCA DE SEGURIDAD	
8	1651 3473	2	HALTER	RETAINER	SUPPORT/PORTEQUTIL	SOPORTE	
9	0139 7609	2	Kette 6x42 D763-16GL	CHAIN/TRACK	CHAINE/CHENILLE	CADENA	
10	0139 7931	2	Z.Feder 3,5x18,5x173	DRAW SPRING	RESSORT TRACTION	RESORTE TRACTION	
11	0112 7538	4	Shb. 10,5 DIN 7349	WASHER	RONDELLE	ARANDELA	
12	0110 8524	4	SHR. M8x20 D603	SCREW	vis	TORNILLO	
13	0621 5666	2	Federstecker 3 A3C	SPRING CLIP	AGRAFE	PASADOR	

K 08

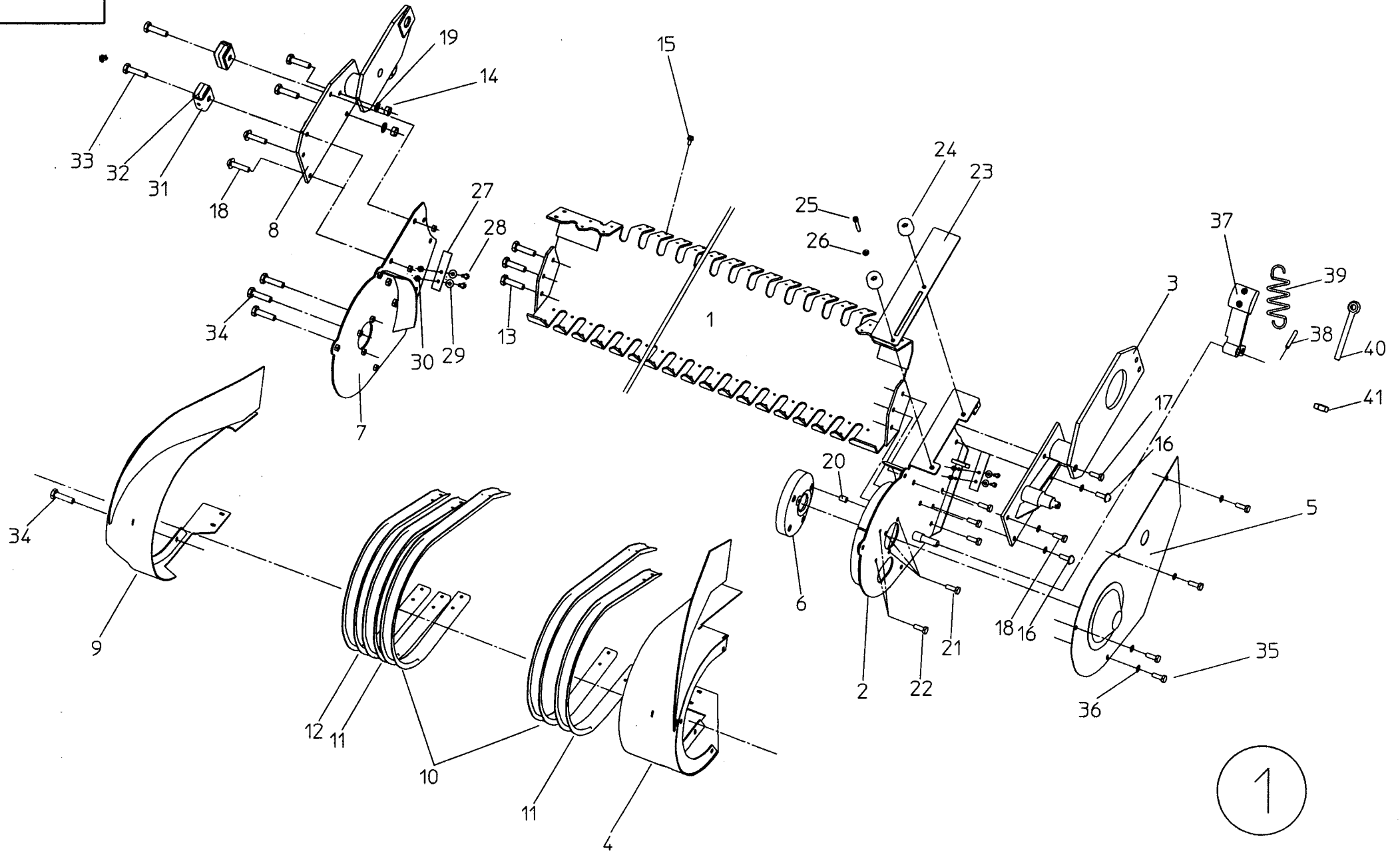

Bildtafel K08

Diagram

Diagramme

Diagrama

Bemerkungen

Notes

Notes

Notas

			Pick-UP 1.8 Abstreifer	Pick-up 1.8 scapper	Pick-up 1.8 racleur	Pick-up 1.8 raspador	
Pos.	Teile-Nr.	Menge	Benennung	Description	Designation	Denominacion	
Pos.	Part.Nr.	Qty.					
Pos.	Piece No.	Qte.					
Pos.	Pieza No.	Cat.					
1	1663 0705	1	Streifblechträger	support	support	soporte	
2	1663 0695	1	Seitenteil li.gsw.	side member left	piecelaterale gau.	pieza lateral izqui	
3	1663 0690	1	PU Halter li.gsw.	retainer left	supporta gauche	soporte izquierda	
4	1663 0716	1	Abdeckung li.gsw.				
5	1663 0738	1	Schutzblech gsw.				
6	0629 6264	1	Steuerkurve innen	steering plate	guide	guia	
7	1663 0700	1	Seitenteil re.gsw.	side member right	piecelaterale dro.	pieza lateral dere.	
8	1663 0710	1	PU Halter re.gsw.	Retainer	support	soporte	
9	1663 0736	1	Abdeckung re.gsw.				
10	1663 0706	24	Streifblech	sheet	tole	chapa	
11	1663 0707	2	Streifblech außen	sheet	tole	chapa	
12	1663 0746	1	Streifblech kurz	sheet	tole	chapa	
13	0111 2418	6	Shr.M10x25 8.8A3C	hex.head screw	vis tete6-pans	torn.cap.hexagonal	
14	0620 9768	4	Sich.Mu.M10 A3C	lock nut	ecrou de securite	tuerca de seguridad	
15	0627 3854	114	Ripp-Schraube M6x10	hex.head screw	vis tete 6-pans	tornillo hex.	
16	0114 2213	2	Flachrundshr.M10x30	truss-head Brew	vis tete bombee	torn.cab.semired.	
17	0111 2429	3	Shr.M10x30 D933	hex.head screw	vis tete 6-pans	torn.cap.hexagonal	
18	0117 3914	3	Shr.M10x25 microv.	hex.bolt	vis 6-pans	tornillo hexagonal	
19	0112 7538	4	Shb.10,5 D7349	washer	rondelle	arandela	
20	1661 4668	3	Sp.stift 11x10 D7346	dowel pin	goupilleserrage	perno fiador	
21	0111 1136	3	Shr.M8x35 microv.	hex.head screw	vis tete6-pans	torn.cap.hexagonal	
22	0620 9476	2	Shr.M8x30 microv.	hex.head screw	vis tete6-pans	torn.cap.hexagonal	
23	1663 0721	1	Kulisse				
24	0114 1112	2	Gummipuffer rund	rubber pad	tampon caoutchouc	tope caucho	
25	1663 0742	2	Shr.M8x35 D912	hex.head screw	vis tete6-pans	torn.cap.hexagonal	
26	0110 7163	2	Shb.9x16x1,6 D126	washer	rondelle	arandela	
27	1663 0734	2	Platte aus Gummi	plate			
28	0111 2264	4	Shr.M6x20	hex.head screw	vis tete6-pans	torn.cap.hexagonal	
29	0621 4189	4	Shb. 6,4x18xl,6	washer	rondelle	arandela	
30	0111 4357	4	Sich.Mu.M6	lock nut	ecrou desecurite	tuerca de seguridad	
31	0657 1322	2	Bügel	yoke	etrier	estribo	
32	0657 1323	4	Anschlag aus Gummi	stop	butee	tope	
33	0111 2451	2	Shr.M10x45	hex.head screw	vis tete 6-pans	torn.cap.hexagonal	
34	0117 3381	9	Shr.M8x20 microv.	hex.head screw	vis tete 6-pans	torn.cap.hexagonal	
35	0114 1006	4	Flachrundshr.M8x16	truss-head srew	vis tete bombee	torn.cab.semired.	
36	0110 2799	4	Federring A8	spring washer	Rondelle elastique	arandela elastica	
37	1663 0745	1	Kettenspanner vorm.	Tensioner	Tendeur de chaine	tensor cadena	
38	0111 5441	1	Spannstift 5x32	dowel pin	Goupille serrage	perno fiador	
39	0621 5561	1	Zugfeder	tension spring	ressort de rappel	resorte de tension	
40	0113 8951	1	Augenschraube 8x50	screw	vis tete	torn.cab.	
41	0111 2824	2	Mu.M8 D934	lock nut	ecrou de secutite	tuerca de seguridad	

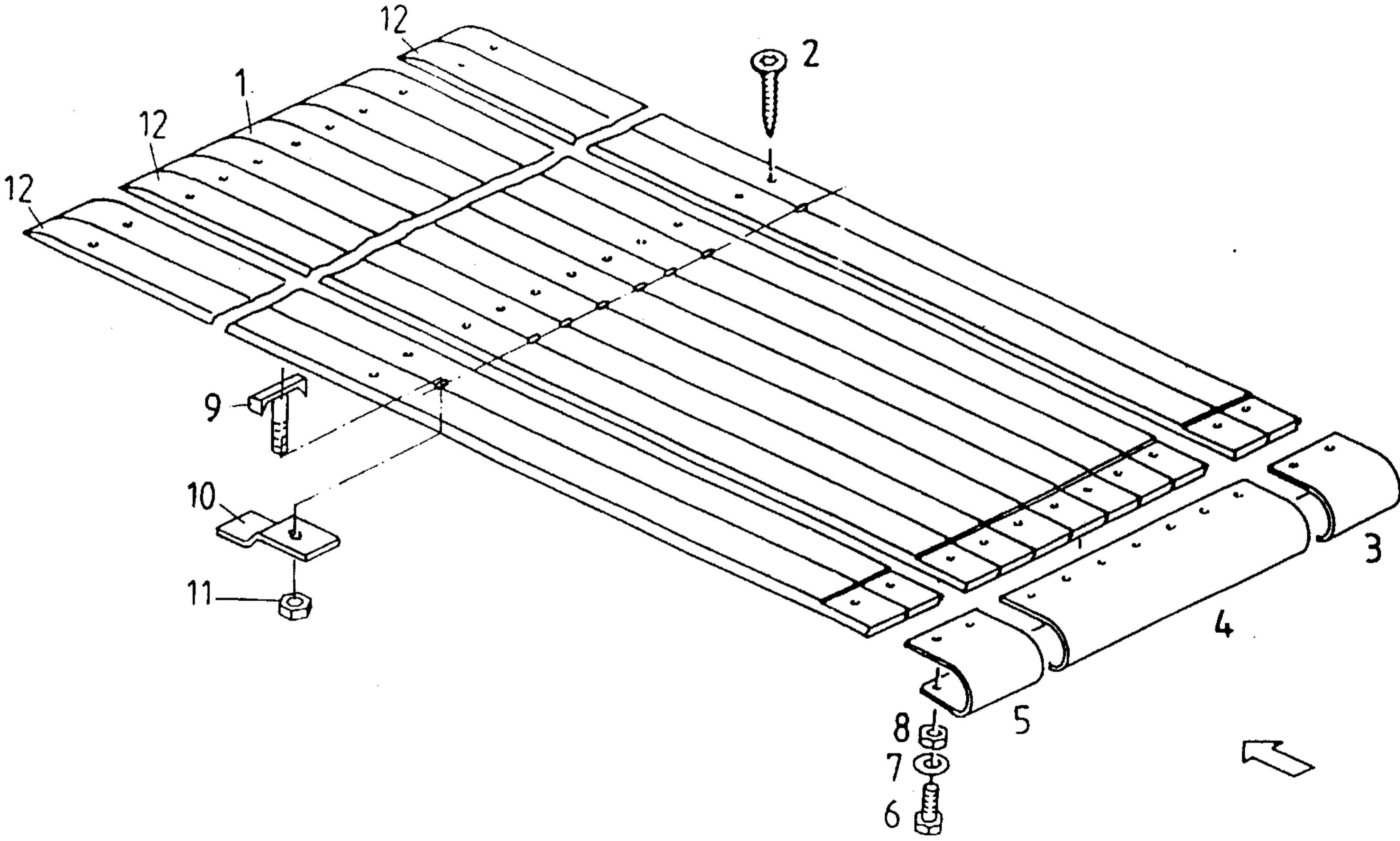

Kratzboden
Bretter

scraper .floor
boards

fond mouvant
planches

fondo rascador
tables

Bildtafel L01

Diagram
Diagramme
Diagrama
Bemerkungen
Notes
Notes
Notas

Pos.	Teile-Nr.	Menge	Benennung	Description	Designation	Denominacion	
Pos.	Part.Nr.	Qty.					
Pos.	Piece No.	Qte.					
Pos.	Pieza	Cat.					
1	1663 0285	8	BODENBRETT	PLANK/BOARD	PLANCHE DE FOND	TABLA PISO	
2	0114 2958	72	Blechschraube	SELF-TAPPING SCREW	VIS	TORNILLO CHAPA	
3	1651 5750	1	DECKBLECH AUSSEN RE.	COVER PLATE	TOLE COUVERTURE	CHAPA RECUBRIM.	
4	1651 5748	1	DECKBLECH INNEN	COVER PLATE	TOLE COUVERTURE	CHAPA RECUBRIM.	
5	1651 5749	1	DECKBLECH AUSSEN LI.	COVER PLATE	TOLE COUVERTURE	CHAPA RECUBRIM.	
6	0111 2322	5	Shr. M 8x20 8.8 A3C.	HEX HEAD SCREW	VIS TETE 6-PANS	TORN.CAB. HEXAGONAL	
7	0621 4193	5	Schb. 8,4x21x3 A3C	WASHER	RONDELLE	ARANDELA	
8	0110 4944	5	Sich. Mu. M8 8A3C	LOCK NUT	ECROU DE SECURITE	TUERCA DE SEGURIDA	
9	0621 3700	8	Klammerschraube	CLAMP SCREW/BOLT	VIS DE SERRAGE	TORNILLO PINZA	
10	1651 1031	8	Klemmplatte	TIGHTENING PLATE	PLAQUE DE SERRAGE	PLACA DE SUJECION	
11	0111 2824	8	Mu. M88A3C	HEX. NUT	ECROU 6-PANS	TUERCA HEXAGONAL	
12	1663 0286	3	Bodenbrett	plank/board	planche de fond	tabl piso	

L 02

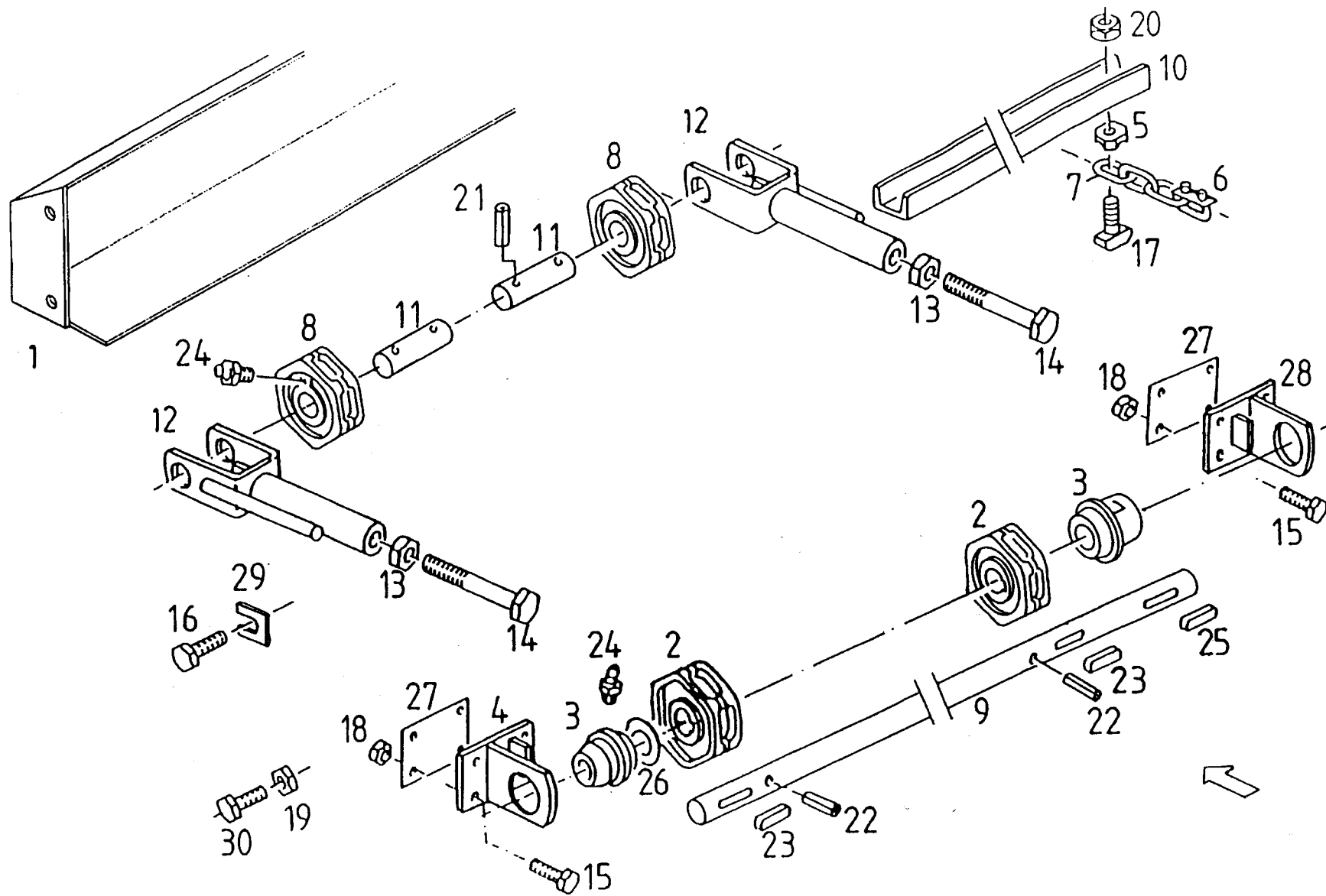

Kratzboden

scraper floor

fond mouvant

fondo rascador

Bildtafel L02

Diagram

Diagramme

Diagrama

Bemerkungen

Notes

Notes

Notas

Pos.	Teile-Nr.	Menge	Benennung	Description	Designation	Denominacion
Pos.	Part.Nr.	Qty.				
Pos.	Piece No.	Qte.				
Pos.	Pieza No.	Cat.				
1	1663 0363	1	Abdeckblech gsw.	cover plate	tole recouvrement	chapa recubrimien.
2	0657 8349	2	Kettenrad f. Kette	CHAIN SPROCKET	PIGNON A CHAINE	PINON DE CADENA
3	0657 7064	2	Lager	FLANGED SLEEVE	MANCHON	SOPORTE
4	0657 8750	1	Lagerplatte re.	SUPPORT PLATE	PLAQUE SUPPORT	PLACA SOPORTE
5	0658 7602	44	Mitnehmerflansch	DRIVE FLANGE	FLASQUE	BRIDA
6	0658 7598	2	Kettenschloß	CHAIN LOCK	JOINT RAPIDE	ESLABON
7	1663 0287	2	KETTE 10X31	CHAIN	CHAINE	CADENA
8	0657 8826	2	KETTENRAD VOLLST.	SPROCKET	ROUE A CHAINES	RUEDA CADENA
9	1663 0284	1	Kratzbodenwelle	AXLE	ESSIEU	EJE
10	0655 8644	22	KRATZSCHIENE	RAIL	BANDE	TABLILLA
11	0657 7030	2	Welle	SHAFT	ARBRE	EJE
12.1	1661 1400	1	SPANNGABEL gsw.li.	TENSION FORK	CHAPE TENDEUR	HORQUILLA TENSORA
12.2	1661 1401	1	SPANNGABEL GSW.RE.	TENSION FORK	CHAPE TENDEUR	HORQUILLA TENSORA
13	0111 2916	2	MU.M20 D934-	HEX. NUT	ECROU 6-PANS	TUERCA HEXAGONAL
14	0620 9411	2	SHR.M20X100D933	HEX.BOLT	VIS 6 PANS	TORNILLO HEXAGONAL
15	0111 2429	4	Shr. M 10x30 88A3C	HEX. HEAD SCREW	VIS TETE 6-PANS	TORN.CAB. HEXAGONAL
16	0620 9464	1	SHR. H2091-DIN 933	hex. head.screw	vis tête 6-pans	tornillo hexagonal
17	0627 3686	44	Hammerschraube	HAMMER BOLT	BOULON	TORNILLO
18	0620 9768	4	Sich.-Mutter M10	LOCK NUT	ECROU DE SECURITE	TUERCA DE SEGURIDAD
19	0620 9769	3	Mu. M 12 8A3C	Lock nut	Ecrou de securite	Tuerca de se uridad
20	0620 9768	44	Sich.-Mutter M10	LOCK NUT	ECROU DE SECURITE	TUERCA DE SEGURIDAD
21	0115 7337	4	Sp.Sift 5X50 Dí481	DOWEL PIN	GOUPILLE SERRAGE	PERNO FIADOR
22	0111 5478	2	Spannstift 8x50	DOWEL PIN	GOUPILLE SERRAGE	PERNO FIADOR
23	0111 8100	2	Paßfeder A 12x8x45	FITTING KEY	CLAVETTE D'AJUSTAGE	DE AJUSTE
24	0112 0692	4	Schmiernippel AM6x1	GREASE NIPPLE	GRAISSEUR A PRESSION	ENGR. A PRESION
25	0111 8111	1	PASSFED. 2x8x80	SUNK KEY	CLAVETTE ENCASTREE	CHAVETA DE AJUSTE
26	0621 4332	4	Schb. 40,5x50,0x1,0	WASHER	RONDELLE	ARANDELA
26.1	0621 4333	1	Schb. 40,5x50,0x2,0	WASHER	RONDELLE	ARANDELA
27	0657 7968	6	BEILAGEBLECH	SHIM	CALE	SUPLEMENTO
28	0655 0287	1	Lagerplatte gsw.	SUPPORT PLATE	PLAQUE SUPPORT	PLACA SOPORTE
29	0655 ^196	6	Beilage	SHIM	CALE	SUPLEMENTO
30	0111 2529	3	Shr.M 12x30 D933	hex. head screw	vis tete 6-pans	torn.cab.hexagonal

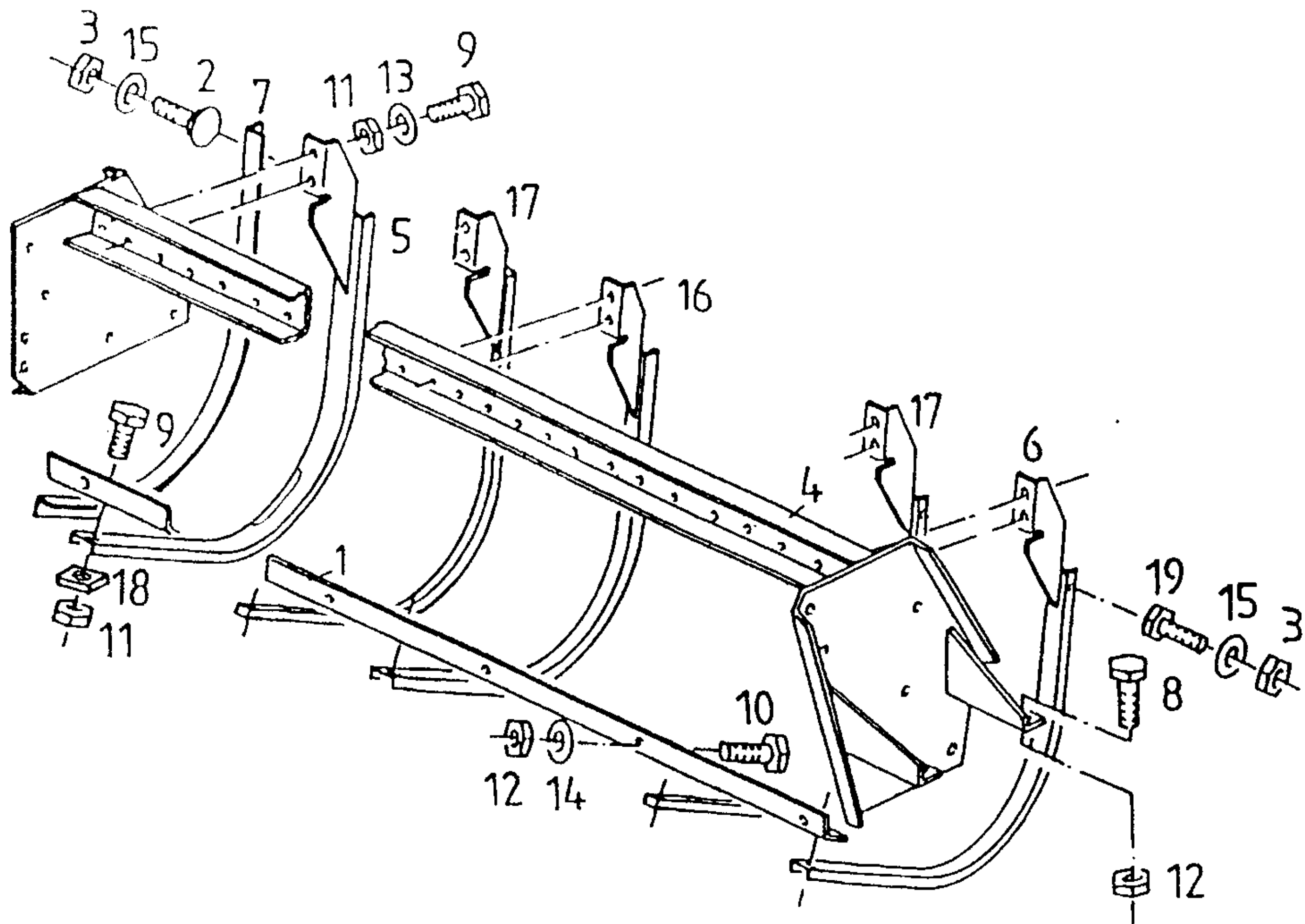

Trommelförderer
Bogenrost 6-Rechen

drum elevator grate

elevat. tambour rouille

elev. a tambor parrilla

Bildtafel L03

Diagram
Diagramme
Diagrama
Bemerkungen
Notes
Notes
Notas

Pos.	Teile-Nr.	Menge	Benennung	Description	Designation	Denominacion
Pos.	Part. Nr.	Qty.				
Pos.	Piece No.	Qte.				
Pos.	Pieza No.	Cat.				
1	1663 0295	1	Bogenblechwinkel	guida rail	fer de guide	ferro de guia
2	0114 2565	6	Flrd.Shr. M 8x20	TRUSS-HEAD SCREW	VIS TETE BOMBEE	TORN.CAB EMIRED.
3	0110 4944	7	Sich. Mu. M8 8A3C	LOCK NUT	ECROU DE SECURITE	TUERCA DE SEGURIDAD
4	1663 0294	1	Bogenblechtr. gsw.	support ort	support	soporte
5	1661 3460	1	Bogenblech gsw.	guide rail	fer de guide	ferro de quia
6	1661 3456	1	Bogenblech li.außen	de rail	fer de guide	ferro de guia
7	0657 7579	1	Bogenwinkel	ANGLE	EQUERRE	ANGULO
8	0620 9459	4	Shr. M 12x35 8 HEX.	HEAD SCREW	VIS TETE 6-PANS	TORNILLO HEX.
9	0111 2429	60	Shr. M 10x30 88A3C	HEX. HEAD SCREW	VIS TETE 6-PANS	TORN.CAB. HEXAGONAL
10	0620 9484	5	Shr. M 12x35 D931	Hex. head screw	Vis tete 6-pans	Tornillo hexagonal
11	0620 9768	60	Sich. Mu. M10 A3C	LOCK NUT	ECROU DE SECURITE	TUERCA DE SEGURIDAD
12	0620 9769	5	Sich. Mu. M'2 8A3C	Lock nut	Ecrou de securite	Tuerca de seguridad
13	0112 7538	40	Shb. 10,5 DIN 7349	WASHER	RONDELLE	ARANDELA
14	0621 4206	5	Schb.13x30x4	WASHER	RONDELLE	ARANDELA
15	0110 7163	7	Schb.9x7x6 A3C	WASHER	RONDELLE	ARANDELA
16	1661 3356	15	Bogenblech gsw.	ride rail	fer de guide	ferro de quia
17	1661 3458	2	Bogenstück 8255 gsw.	bend	ECLISSE coudee	codo
18	0655 2906	17	Lasche	CLIP	CLISSE	ECLISA
19	0111 2322	1	Shr. M 8x20 8.8 A3C	HEX. HEAD SCREW	VIS TETE 6-PANS	TORN.CAB. HEXAGONAL

L 04

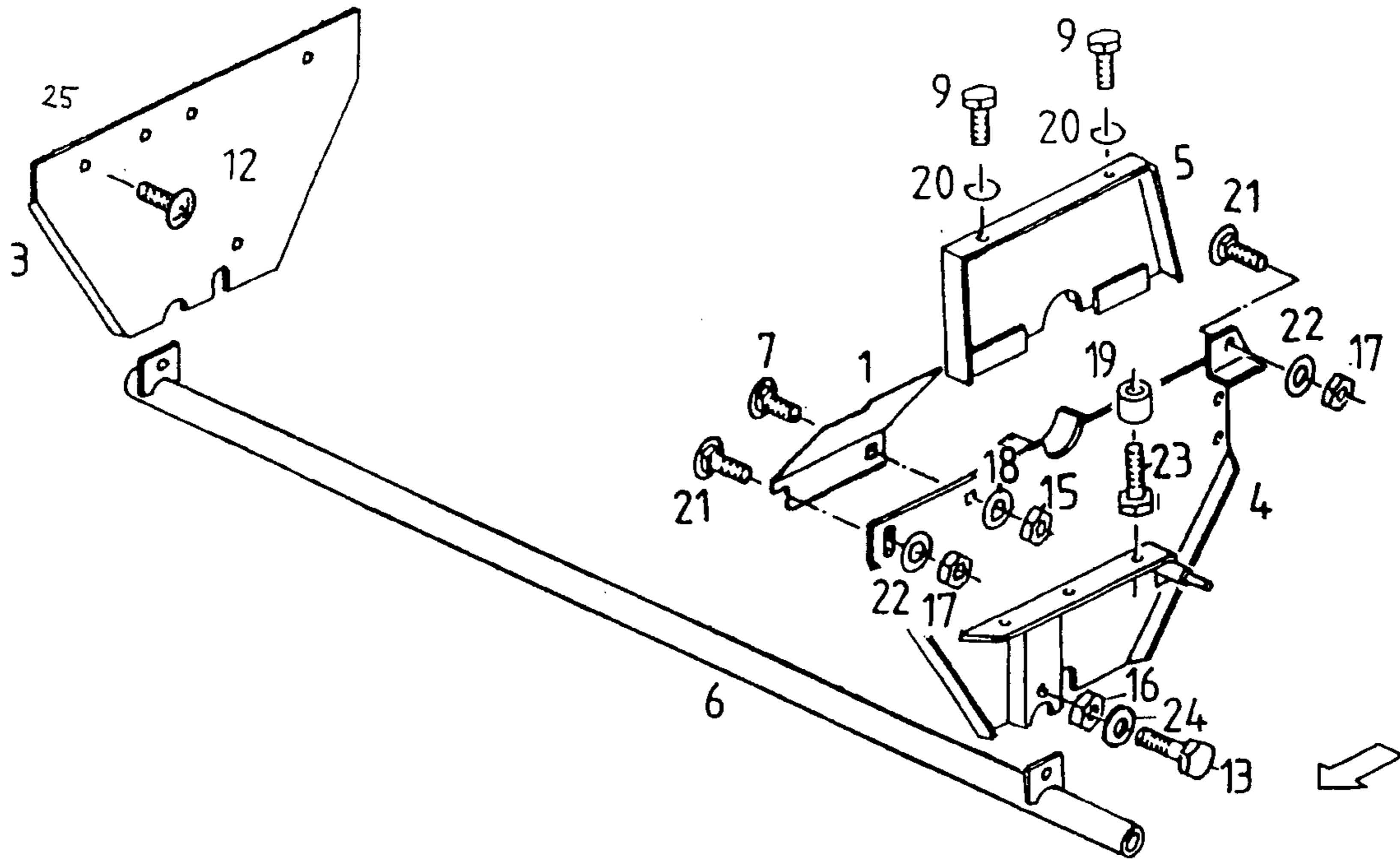

Trommelförderer
Seitenwand

drum elevator side mem.
a. cov .sheet

elevat. a. tambour lat.et
tole d.rec.

elevad. d. Tambor
lat. y chapa de prot

Bildtafel L04

Diagram
Diagramme
Diagrama

Bemerkungen
Notes
Notes
Notas

Pos.	Teil e-Nr.	Menge	Benennung	Description	Designation	Denomination	Bemerkungen
Pos.	Part. Nr.	Qty.					Notes
Pos.	Pi ece No.	Qte.					Notes
Pos.	Pi eza No.	Cat.					Notas
1	1663 0389	1	Abdeckblech	SHEET	TOLE	TAPA	
3	1663 0276	1	Seitenwand re. gsw.	SIDE MEMBER R	PAROI LATERALS R	PARED LATERAL R	
4	1663 0559	1	Seitenwand li. gsw.	SIDE MEMBER L	PAROI LATERALS L	PARED LATERAL L	
5	0657 7389	1	Deckblech gsw.	COVERING SHEET	TOLE DE RECOUVREM.	CHAPA DE PROT.	
6	0657 7391	1	Querrohr gsw.	CROSS TUBE	TUBE TRANSVERSAL	TUBO TRANSVERSAL	
7	0113 8989	1	SHR.M6x16 D603	TRUSS-HEAD SCREW	VIS TETE BOMBEE	TORN.CAB.SEMIRED.	
9	0111 2407	2	Shr.M10x20 D933	HEX. HEAD SCREW	VIS TETE 6-PANS	TORN.CAB. HEXAGONAL	
12	1663 0448	4	Linsenshr.10.9 M12x35	HEX. HEAD SCREW	VIS TETE 6 PANS	TORN.CAB.HEXAGONAL	
13	0111 2709	2	SHR.M16X110 D933	HEX.BOLT	VIS 6 PANS	TORNILLO HEXAGONAL	
15	0111 4357	1	Mu.M6 8A3C	LOCK NUT	ECROU DE SECURITE	TUERCA DE SEGURIDAD	
16	0111 2886	2	MU.M16 8A3C D934	HEX. NUT	ECROU 6-PANS	TUERCA HEXAGONAL	
17	0620 9768	2	Sich.-Mutter MI A3C	LOCK NUT	ECROU DE SECURITE	TUERCA DE SEGURIDAD	
18	0621 4189	1	Scheibe 6,4x18x2	WASHER 6,4X18X2	RONDELLE 6,4X18X2	ARANDELA 6,4X18X2	
19	0657 1325	3	Abstandring	SPACER RING	BAGUE ENTRETOISE	ANNILLO DISTANCIADOR	
20	0110 2800	2	Fedr. A10 DIN 128	SPRING WASHER	RONDELLE ELASTIQUE	ARANDELA ELASTICA	
21	0620 7557	2	SHR.M10 x 25 8.8 A3C	SAUCER HEAD SCREW	VIS A TETE BOMBEE	TORN. CAB. BOMBEADA	
22	0110 7165	2	Scheibe 11,0 A3C	WASHER	RONDELLE	ARANDELA	
23	0620 9245	3	SHR. H2091 DIN 931	HEX.BOLT	VIS 6 PANS	TORNILLO HEXAGONAL	
24	0116 9697	2	Sich.Shb. 16 H2203	RETAINING WASHER	BAGUE DE FREIN	ARANDELA SEGURIDAD	
25	0620 9769	4	Sich.-Muter M12	LOCK NUT	ECROU DE SECURITE	TUERCA DE SEGURIDAD	

L 05

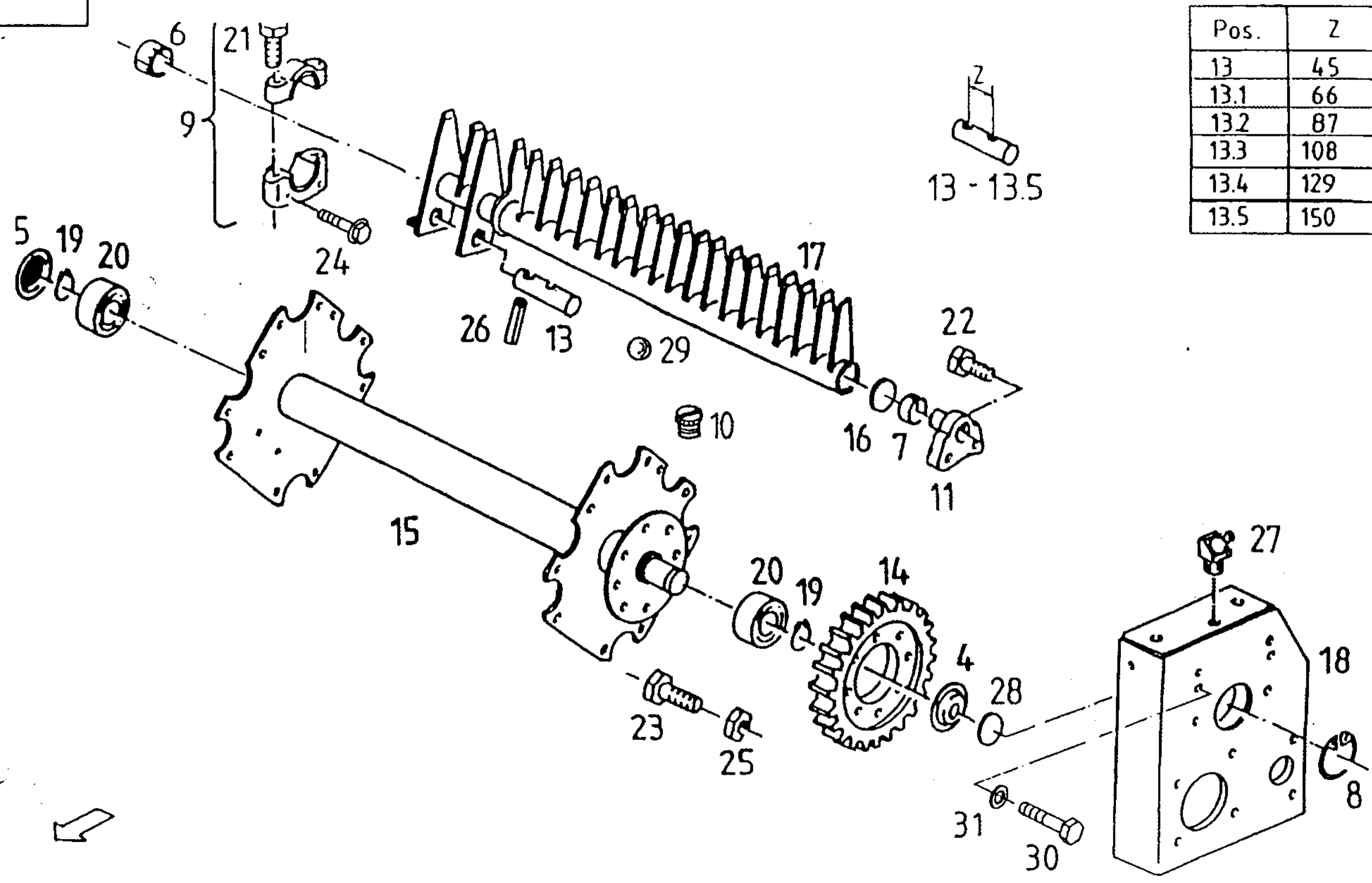

Pos.	Z
13	45
13.1	66
13.2	87
13.3	108
13.4	129
13.5	150

Bildtafel L05

Diagram

Diagramme

Diagrama

Bemerkungen

Notes

Notes

Notas

Pos.	Toile-Nr.	Menge	Benennung	Description	Designation	Denomination
Pos.	Part. Nr.	Qty.				
Pos.	Piece No.	Qte.				
Pos.	Pieza No.	Cat.				
4	1651 6663	1	Deckel	COVER	COUVERCLE	TAPA
5	0657 7317	1	Deckel.	CAP	CHAPEAU	TAPA
6	1651 5167	24	Lagerhalbschale	BEARING BRASS	CUVETTE/COQUILLE	PLATO/CASQ.COJIN
7	0114 2086	6	Buchse	BUSH	MANCHON	MANGUITO
8	0110 7858	1	Sich.Ring 90x3	CIRCLIP	CIRCLIP	ANILLO DE SEGURIDAD
9	1651 5168	6	Lager mont.	BEARING/SUPPORT	PALIER/SUPPORT	SOPORTE/COJINETE
10	0621 6527	1	KAPSTOPFEN	PROTECTING PLUG	BOUCHON DE	TAPON-DE PROTECTION
il	0657 1150	6	Flanschzapfen	FLANGED PIN	AXE A FLASQUE	PERNO CON BRIDA
13	1651 6653	1	Steuerbolzen Z=45	PIN/BOLT/STUD	BOULON/AXE	BULON
13.1	1651 6654	1	Steuerbolzen Z=66	pin/bolt/stud	boulon/axe	bulon
13.2	1651 6655	1	Steuerbolzen Z=87	pin/bolt/stud	boulon/axe	bulon
13.3	1651 6656	1	Steuerbolzen Z=108	pin/bolt/stud	boulon/axe	bulon
13.4	1651 6657	1	Steuerbolzen Z=129	valve	soupape	valvula
13.5	1651 6658	1	Steuerbolzen Z-150	pin/bolt/stud	boulon/axe	bulon
14	0657 7335	1	Stirnrad 39Z/M8	SPUR GEAR	PIGNON DROIT	RUEDA DENTADA RECTA
15	1651 3977	1	Trommel gsw.	DRUM/REEL	TAMBOUR	TAMBOR
16	0657 8868	6	Scheibe	WASHER/DISC/PLATE	RONDELLE/DISQUE	DISCO/ARANDELA
17	1663 0142	3	Rechen gsw.	rake	rateau	rastrillo
17.1	1663 0143	3	Rechen gsw.	rake	rateau	rastrillo
18	1663 0557	1	LAGERPLATTE GSW.	SUPPORT PLATE	PLAQUE SUPPORT	PLACA SOPORTE
19	0113 7321	1	Sich-Ring40x2,5	RING	BAGUE	ANILLO
20	0114 1159	2	Pendelrollenlager	ROLLER BEARING	ROULEMENT A ROTULE	RODAM.DE RODILLOS
21	0627 3763	12	SHR.M12x60 DIN931	HEX.HEAD SCREW	VIS TETE 6-PANS	TORN. HEXAGONAL
22	0627 3771	12	SHR.M16X30 DIN933	HEX. HEAD SCREW	VIS TETE 6-PANS	TORN. HEXAGONAL
23	0111 2683	8	SHR.M16X 40D933	HEX. HEAD SCHREW	VIS A TETE 6-PANS	TORNILLO HEXAGONAL
24	0114 2796	12	Ripp-Schraube M16x55	HEX.BOLT	VIS 6 PANS	TORNILLO HEXAGONAL
25	0112 7856	8	Si.Mu.M16 D985 8A3C	LOCK NUT	ECROU DE SECURITE	TUERCA DE SEGURIDAD
26	0115 7381	6	Spannstift 10x60 DIN	DOWEL PIN	GOUPILLE SERRAGE	PERNO FIADOR
27	0112 0696	2	Schmiernippel BM6x1	GREASE NIPPLE	GRAISSEUR A PRESSION	ENGR. A PRESION
28	1651 6754	1	Gummitülle	Rubber GROMMET	BAGUE PASSE-CABLE	FUNDA CAUCHO
29	0111 6946	6	Kugel 6,35-III-D5401	ball	bille	bola
30	1663 0547	4	Shr.M16x120 D931	HEX. HEAD SCREW	VIS TETE 6-PANS	TORNILLO HEX.
31	0114 2841	4	Sich.Scheibe HS16	LOCKING WASHER	RONDELLE SECURITE	ARANDELA SEGURIDAD

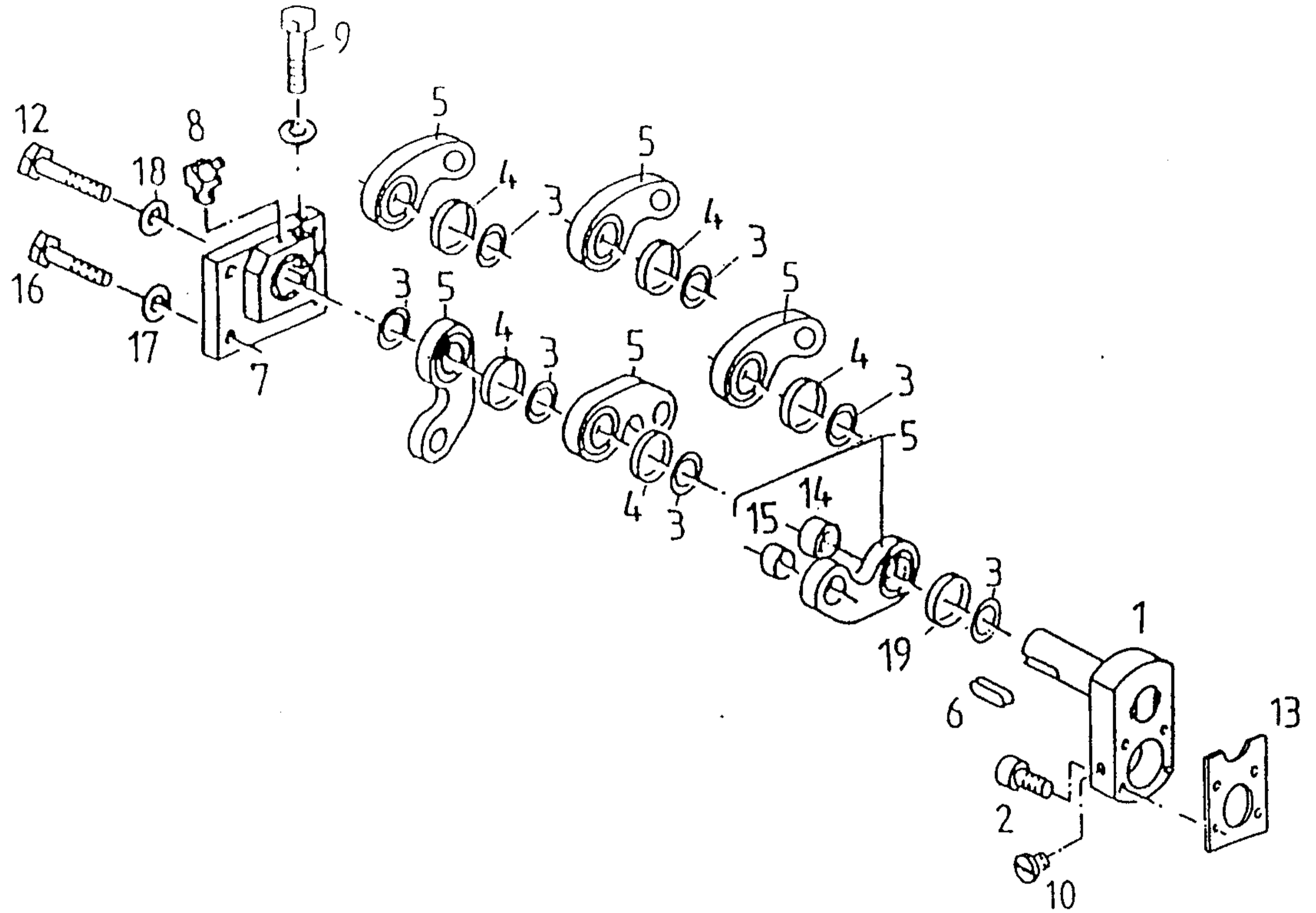

Bildtafel L06

Diagram
Diagramme
Diagrama
Bemerkungen
Notes
Notes
Notas

Pos.	Teile-Nr.	Menge	Benennung	Description	Designation	Denomination
Pos.	Part.Nr.	Qty.				
Pos.	Piece No.	Qte.				
Pos.	Pieza No.	Cat.				
			Trommelförderer	drum elevator	elevat. a. tambour	elevad. d. tambor
			Kurbel mit Lager	crank with bearing	manivelle et couss.	maniv. y cojinete
			6 Rechen	6 rake	6 rateau	6 rastrillo
1	1651 5089	1	Kurbellager vollst.	CRANK BEARING	COUSSINET	COJINETE
2	0627 3756	4	SHR. H2091- DIN 912	SOCKET HEAD SCREW	VIS A 6-PANS CREUX	TORN. C. HEXAGONO
3	0627 3873	9	Axialscheibe AS7095	NEEDLE BEARING	ROULEM.A AIGUILLES	COJ. AGUJAS
4	0658 7559	6	Dichtring	SEAL RING	BAGUE DE JOINT	ANILLO DE JUNTA
5	1651 6536	6	Lenker vollst.	AXLE LINK	BRAS DE SUSPENSION	ELEMENTO GUIA
6	0627 7509	2	Passfed.AB18x11x54	SUNK KEY	CLAVETTE ENCASTREE	CHAVETA DE AJUSTE
7	1651 6772	1	KURBELFLANSCH GSW.	FLANGE	BRIDE/COLLET	BRIDA
8	0112 0697	1	Schmiernippel BM H2	GREASE NIPPLE	GRAISSEUR A PRESSION	ENGRASADOR
9	0627 3759	2	Shr.M16x100 D931	HEX. HEAD SCREW	VIS TETE 6-PANS	TORNILLO HEX.
10	0621 6527	1	Stopfen	PROTECTING PLUG	BOUCHON DE	TAPON DE PROTECTION
12	1663 0549	9	Shr. M20x130 D931	HEX.BOLT	VIS 6 PANS	TORNILLO HEXAGONAL
13	0655 3944	1	Lagerdeckel	COVER	COUVERCLE	TAPA
14	1663 0146	6	Buchse	bearing bush	coussinet	buje
15	0627 7517	6	Buchse	BEARING BUSH	COUSSINET	BUYE
16	1663 0548	4	SHR.M16X130 D931	HEX.BOLT	VIS 6 PANS	TORNILLO HEXAGONAL
17	0114 2841	6	Sich.Scheibe HS16	LOCKING WASHER	RONDELLE SECURITE	ARANDELA SEGURIDAD
18	0114 2842	11	Sich.Scheibe HS20	LOCKING WASHER	RONDELLE SECURITE	ARANDELA SEGURIDAD
19	1663 0145	1	Dichtring breit	seal ring	bague de joint	anillo de junta

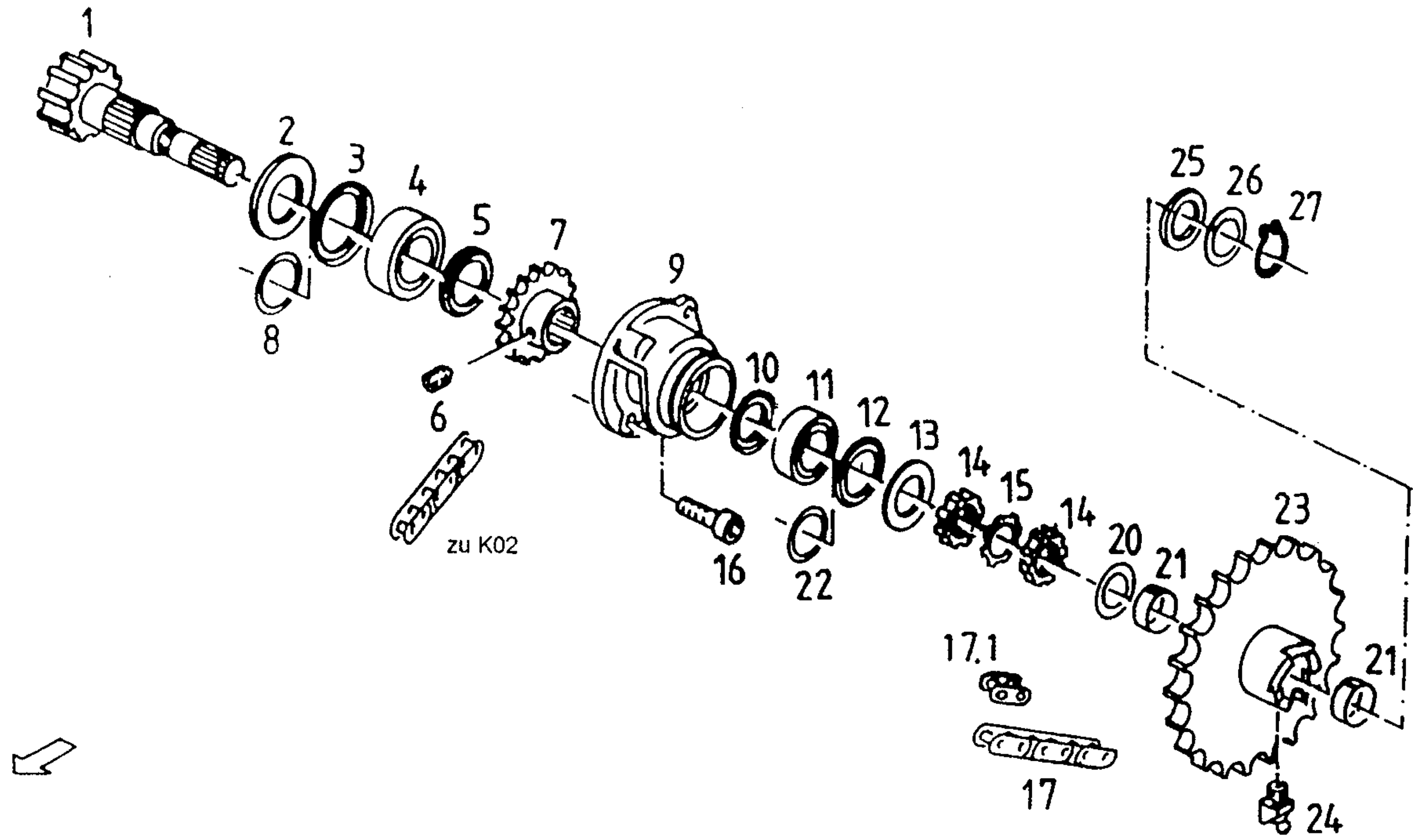

Trommelförderer
Ritzelwelle

drum elevator
pinion shaft

elevat. a. tambour
arbre de pinion

elevad. d. tambor
eje pinion

Bildtafel L07

Diagram
Diagramme
Diagrama
Bemerkungen
Notes
Notes
Notas

Pos.	Teile-Nr.	Menge	Benennung	Description	Designation	Denominacion
Pos.	Part.Nr.	Qty.				
Pos.	Piece No.	Qte.				
Pos.	Pieza No.	Cat.				
1	0657 1032	1	Ritzelwelle Z=11	PINION SHAFT	ARBRE DE PIGNON	EJE PINON
2	0657 1205	1	DICHTSCHEIBE	SEALING WASHER	RONDELLE D'ETANCH	ARANDELA HERMETIZ.
3	0621 4950	1	Nilosring 30212 AV	NILOS RING	ANNEAU NILOS	ANILLO NILOS
4	0110 9962	1	Kr-lag.30212	TAPER R. BEARING	ROULEM. A ROULEAUX	RODAM. DE RODILLOS
5	0627 3872	1	NILOS 1. 30212 JV	NILOS RING	ANNEAU NILOS	ANILLO NILOS
6	0620 8934	1	Gewindestift DIN 914	FITTING	CLAVETTE	CHAVETA DE AJUSTE
7	0657 0914	1	KETTENRAD Z19	CHAIN SPROCKET	PIGNON A CHAINE	PINON DE CADENA
8	0113 7990	1	Paßscheibe 60x75x1,0	SPACER	RONDELLE D'EPaisseur	ARANDELA DE ESPESOR
9	0657 7305	1	LAGERGEHAEUSE	BEARING HOUSING	BOITIER DE COUSSINET	CAJA DE COJINETE
10	0621 4948	1	NILOSRI. 30210 AV	NILOS RING	ANNEAU NILOS	ANILLO NILOS
11	0110 9960	1	Kr-lag.30210	TAPER R. BEARING	ROULEM. A ROULEAUX	RODAM. DE RODILLOS
12	0627 3871	1	Nilosring 30210 TV	NILOS RING	ANNEAU NILOS	ANILLO NILOS
13	0657 0007	1	Dichtscheibe	SEALING WASHER	RONDELLE D'ETANCH	ARANDELA HERMETIZ.
14	0112 0613	2	Nutmutter	GROOVED NUT	ECROU RAINURE	TUERCA RANURADA
15	0112 0671	1	SICH.BL.	LOCKING PLATE	ARRETOIR	PLATINA DE SEGURIDAD
16	0117 5657	4	SHR. H2091 DIN 912	CHEESE-HEAD SCREW	VIS TETE CYLINDR.	TORN.CBZA.CILIND.
20	0621 5016	1	Ax-Schb. AS 4565	THRUST WASHER	BAGUE BUTEE AXIALE	ARANDELA AXIAL
21	0113 9735	2	Buchse	BUSH	DOUILLE	CASQUILLO
22	0621 4504	1	Pass-Schb. 50x62x1	SPACER	RONDELLE D'EPaisseur	ARANDELA DE ESPESOR
23	1663 0384	1	Kupplungsnahe mont.	HUB	MOYEU ACCOUP.	CABO ACOPLAMIENTO
24	0112 0700	1	Kegel-Schmiernippel	GREASE NIPPLE	GRAISSEUR A PRESSION	ENGR. A PRESION
25	0657 1033	1	RING	RING	BAGUE/ANNEAU	ANILLO
26	0621 4500	1	Paßscheibe 45x55x1,0	SPACER	RONDELLE D'EPaisseur	ARANDELA DE ESPESOR
26.1	0621 4499	1	Paßscheibe 45x55x0,5	SPACER	RONDELLE D'EPaisseur	ARANDELA DE ESPESOR
26.2	0113 7130	1	Stützscheibe 45x55x3	SPACER RING	BAGUE DE SUPPORT	ANILLO APOYO
27	0112 4663	1	Sich.-Ring 45x2,5	CIRCLIP	CIRCLIP	CIRCLIP

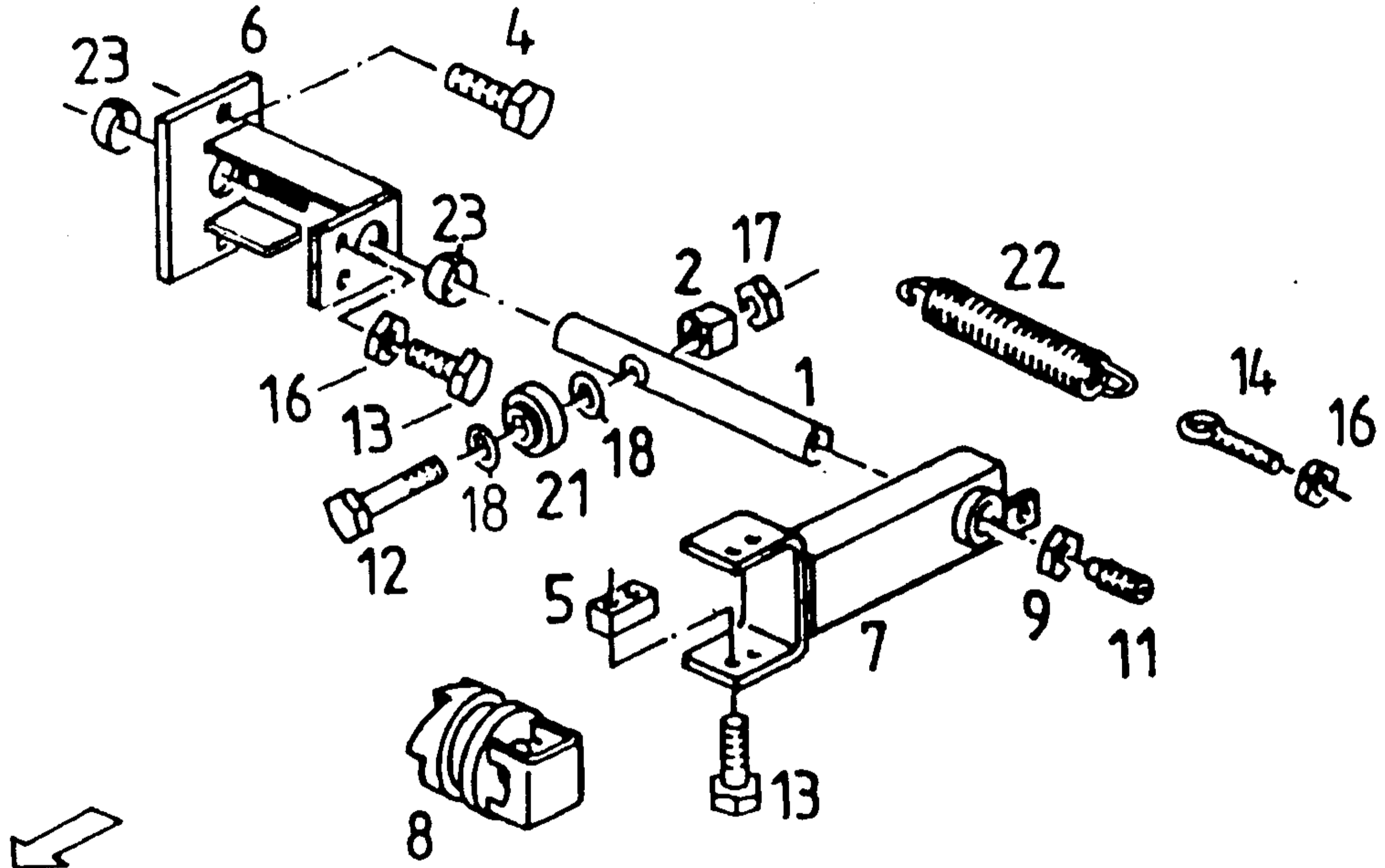

Trommelförderer
A u s r ü c k e r

Drum elevator
release lever

Elevat. a. Tambour
levier debayeur

Elevad.d.tambor
palanca desembrage

Bildtafel L08

Diagram
Diagramme
Diagrama
Bemerkungen
Notes
Notes
Notas

Pos.	Teile- Nr.	Menge	Benennung	Description	Designation	Denomination
Pos.	Part. Nr.	Qty.				
Pos.	Piece No.	Qte.				
Pos.	Pieza No.	Cat.				
1	0657 7348	1	Bolzen	PIN	AXE	PERNO
2	0657 7349	1	Führungsstück	GUIDE PIECE	PIECE DE GUIDAGE	PIEZA DE GUIA
4	0627 7504	2	Shr H2Q91 DIN 933	HEX. HEAD SCREW	VIS TETE 6-PANS	TORNILLO HEX.
5	0658 7560	2	GLEITSTUCK	SLIDE PIECE	PIECE COULISSANTE	PIEZA CORREDIZA
6	1663 0385	1	Ausrückhalter m.Bu.	support with bush	support avec manchon	soporte con manguito
7	0657 7385	1	Ausrückgabel gsw.	DISCONN.FORK	FOURCH. DEBRAYAGE	HNQUILLA DESEMBR.
8	0655 6728	1	SCHIEBEKLAUE GESCHW.	SLIDE CLATCH	GRIFFE COULISSANTE	GARRA CORREDIZA
9	0113 7252	1	Mutter BM 12	HEXNUT	ECROU 6-PANS	TUERCA -HEXAGONAL
il	0620 8962	1	Gew.-St-M12x30 D915	THREADED PIN	GOUJON FILETE	ESPIGA ROSCADA
12	0111 1545	1	SHR-M12X 90D931	HEX. BOLT	VIS 6 PANS	TORNILLO HEXAGONAL
13	0111 2333	6	Shr. M 8x25 88A3C	HEX. HEAD SCREW	VIS TETE 6-PANS	TORN.CAB. HEXAGONAL
14	0113 8951	1	A. SHR.LBM 8X 50	EYE BOLT	VIS A OEIL	TORNILLO CON OJETE
16	0111 2824	4	Mu. M 8 8A3C	HEX. NUT	ECROU 6-PANS	TUERCA HEXAGONAL
17	0620 9769	1	Mu. M 12 8A3C	Lock nut	Ecrou de securite	Tuerca de seguridad
18	0621 4207	3	Scheibe 13x24x2,5A3C	WASHER	RONDELLE	ARANDELA
21	0621 5029	1	Laufrolle Lieferv.	ROLLER	ROULEAU	RODILLO
22	0621 5561	1	Zugfeder 4,5x20x180	TENSION SPRING	RESSORT DE RAPPEL	RESORTE DE TENSION
23	0627 7514	2	BUCHSE 35W39x'5-Y1-	BUSH	MANCHON	MANGUITO

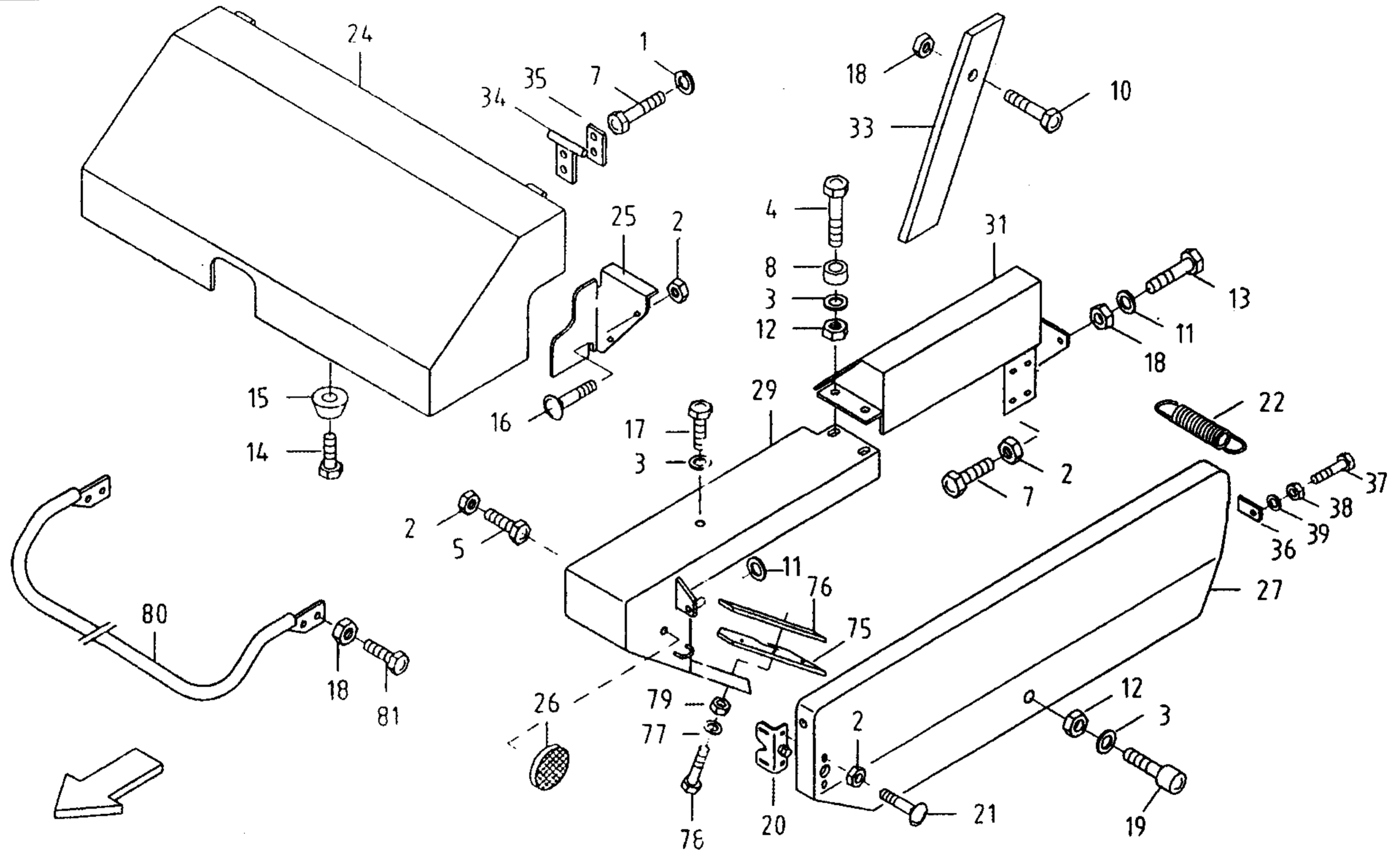

Pos.	Teile-Nr.	Menge	Benennung	Description	Designation	Denominacion
Pos.	Part.Nr.	Qty.				
Pos.	Piece No.	Qte.				
Pos.	Pieza No.	Cat.				
			Schutzhaube	Protection hood	capot protection	cofia de protection
1	01102799	4	Federring	SPRING WASHER	RONDELLE ELASTIQUE	ARANDELA ELASTICA
2	0110 4944	6	Sich. Mu. M8 8A3C	LOCK NUT	ECROU DE SECURITE	TUERCA DE SEGURIDAD
3	0621 4189	7	Scheibe 6,4x18x2	WASHER 6,4X18X2	RONDELLE 6,4X18X2	ARANDELA 6,4X18X2
4	0111 1079	2	SHR M 6x 50 DIN931	HEX.BOLT	VIS 6 PANS	TORNILLO HEXAGONAL
5	0111 1153	1	SHR.M8x45 D931 88	HEX. HEAD SCREW	VIS TETE 6-PANS	TORN. CAB. HEXAGONAL
5.1	01112322	1	Shr. M 8x20 8.8 A3C	HEX. HEAD SCREW	VIS TETE 6-PANS	TORN.CAB. HEXAGONAL
7	01112331	6	SHR. M 8;;16 D933	HEX. HEAD SCREW	VIS TETE 6-PANS	TORN.CAB. HEXAGONAL
8	1651 8913	2	ROHR	PIPE/TUBE	TUBE/TUYAU	TUBO,
10	0111 2429	1	Shr. M 10x_;0 88A3C	HEX. HEAD SCREW	VIS TETE 6-PANS	TORN.CAB. HEXAGONAL
11	0110 7165	2	Scheibe 11,0 A3C	WASHER	RONDELLE	ARANDELA
12	0111 4357	3	Mu. M6 8A3C	LOCK NUT	ECROU DE SECURITE	TUERCA DE SEGURIDAD
13	0111 2407	1	Shr. M 10x20 D933	HEX. HEAD SCREW	VIS TETE 6-PANS	TORN.CAB. HEXAGONAL
14	0112 6049	2	ZYL.SHR.AM 6	CYLINDRICA SCREW	VIS CYLINDRIQUE	TORNILLO CILINDRICA
15	0114 1112	2	Gummipuffer	RUBBER PAD	TAMPON CAOUTCHOUC	TOPE CAUCHO
16	0114 1006	2	Fird.Shr. M 8x16	TRUSS-HEAD SCREW	VIS TETE BOMBEE	TORN.CAB.SEMIRED.
17	0621 4132	1	Fird.Schraube 16x16	SAU°ER HEAD SCREW	VIS A TETE BOMBEE	TORNILLO
18	0620 9768	6	Sich.-Mutter M10 A3C	LOCK NUT	ECROU DE SECURITE	TUERCA DE SEGURIDAD
19	0114 2826	1	Gummipuffer	RUBBER PAD	TAMPON CAOUTCHOUC	TOPE CAUCHO
20	16611457	1	Klappenverschluss	Foldin vastener	Fermeture trappe	Cierre trampilla
21	0114 2565	2	Flr Shr. M 8x20	TRUSS-HEAD SCREW	VIS TETE BOMBEE	TORN.CAB.SEMIRED.
22	1661 3359	1	Z.Fed. 3,4/30,0/91,0	Tension spring	Ressort de rappel	Muelle de traccion
24	1663 0590	1	SCHUTZHAUBE	HOOD	CAPOT PROTECTEUR	SOMBRERETE PROTEC.
25	0657 9350	1	Abdeckblech gsw.	COVER PLATE	TOLE RECOUVREMENT	CHAPA RECUBRIMIEN.
26	0621 4037	6	Rückstrahler D60	REAR REFLECT	CATAPHOTE JAUNE	OJO DE GATO AMARILLO
27	1663 0351	1	Schutzhaube li. gsw.	HOOD LEFT	CAPOT PROTE. Angouche	SOMBRER.PROTEC.IZQU.
29	1663 0337	1	Mantelblech gsw.	JACKET PLATE	TOLE D'ENVELOPPE	CHAPA ENVOLVENTE
31	1663 0335	1	Abdeckblech geschw.	COVER PLATE	TOLE RECOUVREMENT	CHAPA RECUBRIMIEN.
33	0657 7514	1	Stütze	SUPPORT	SUPPORT	SOPORTE
34	0657 7521	2	Scharnier gsw.	HINGE	CHARNIERE	CHARNELA
35	1663 0594	2	Beilage			
36	1663 0586	1	Anschlag			
37	0111 1319	1	Shr.M10x60 D93388	HEX. HEAD SCREW	VIS TETE 6-PANS	TORN.CAB. HEXAGONAL
38	01112841	1	Mu.M10 D934 8A3C	LOCK NUT	ECROU DE SECURITE	TUERCA DE SEGURIDAD
39	0112 7538	2	Scheibe 10,5 D7349	WASHER	RONDELLE	ARANDELA
75	1661 1397	1	Gummilappen	strip	Bande caoutchouc	Tira de caucho
76	1661 1398	1	Leiste	STRIP	LISTEAU/MOULURE	LISTON
77	01107095	3	Scheibe 6,1 A3C	WASHER./DISC/PLATE	RONDELLE/DISQUE	DISCO/ARANDELA
78	011.1 2264	3	Shr. M 6x20 DIN 933	HEX. HEAD SCREW	VIS TETE 6-PANS	TORN.CAB. HEXAGONAL
79	0111 4357	3	Mu. M6 8A3C	LOCK NUT	ECROU DE SECURITE	TUERCA DE SEGURIDAD
80	1661 1431	1	Schutzbügel	PROTECTIVE YOKE	ETRIER PROTECTION	ESTRIBO PROTECC.
81	0111 2439	4	SHR.M10x 5 D933	HEX. HEAD SCREW	VIS TETE 6-FANS	TORN.CAB. HEXAGONAL

Bildtafel M01

Diagramme

Diagrama

Bemerkungen

Notes

Notes

Notas

M 03

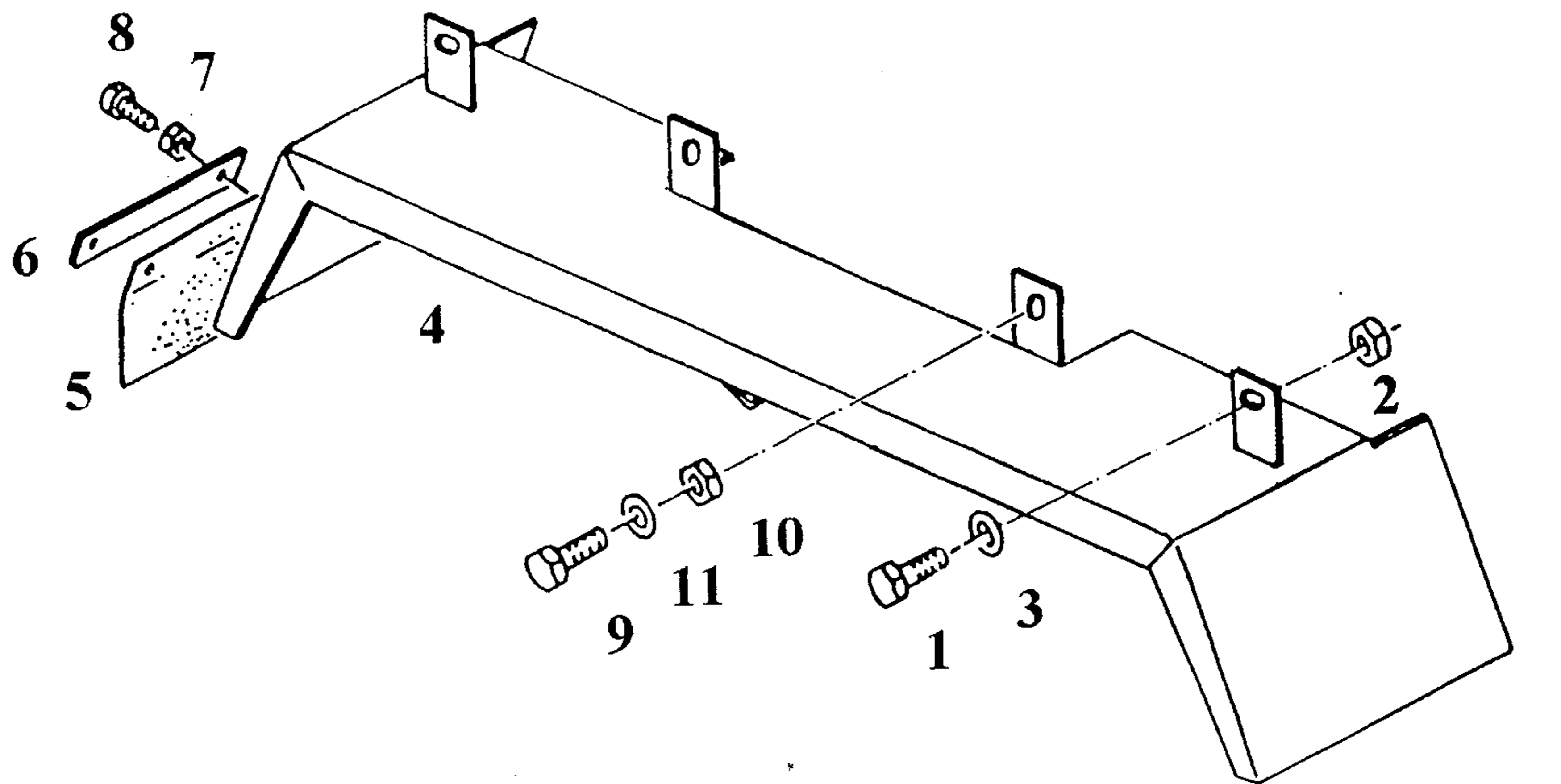

Kotflügel
Tandem-Achse

mudguard
Tandem axle

afile
essieu tandem

guardabarros
eje tandem

Bildtafel M 03

Diagram
Diagramme
Diagrama
Bemerkungen
Notes
Notes
Notas

Pos.	Teile-Nr.	Menge	Benennung	Description	Designation	Denomination	
Pos.	Part.Nr.	Qty.					Notes
Pos.	Piece No.	Qte.					Notes
Pos.	Pieza No.	Cat.					Notas
1	0111 2447	4	Shr.M10x10 D933	HEX.HEAD SCREW	VIS TETE 6 PANS	TORN.CAB.HEXAGONAL	
2	0620 9768	4	Sich.Mu. M10 10A3C	LOCK NUT	ECROU DE SECURITE	TUERCA DE SEGURIDAD	
3	0621 4197	8	Shb.10,5x30x5 A3C	WASHER	RONDELLE	ARANDELA	
4	1663 0595	2.	Kotflügel gsw	MUDGUARD	GARDA-BOUE	GUARDABARROS	
5	0657 7918	2	GUMMILAPPEN	SUPPOR	SUPPORT	SOPORTE	
6	0657 7919	2	Leiste	STRIP	LISTEAU/MOULURE	LISTON	
7	0111 4357	8	Mu.M6 8A3C	LOCK NUT	ECROU DE SECURITE	TUERCA DE SEGURIDAD	
8	0113 3784	8	ZYL.SHR.AM6X16	CHEESE HEAD SCREW	VIS TETE CYLINDRIQUE	TORNILLO CILINDRICO	
9	1663 0598	4	Shr. M12x45 10.9	HEX. HEAD SCREW	VIS TETE 6 PANS	TORN.CAB.HEXAGONAL	
10	0620 9778	4	Sich.Mu.M12	LOCK NUT	ECROU DE SECURITE	TUERCA DE SEGURIDAD	
11	0621 4207	4	Shb.13 D125	WASHER	RONDELLE	ARANDELA	

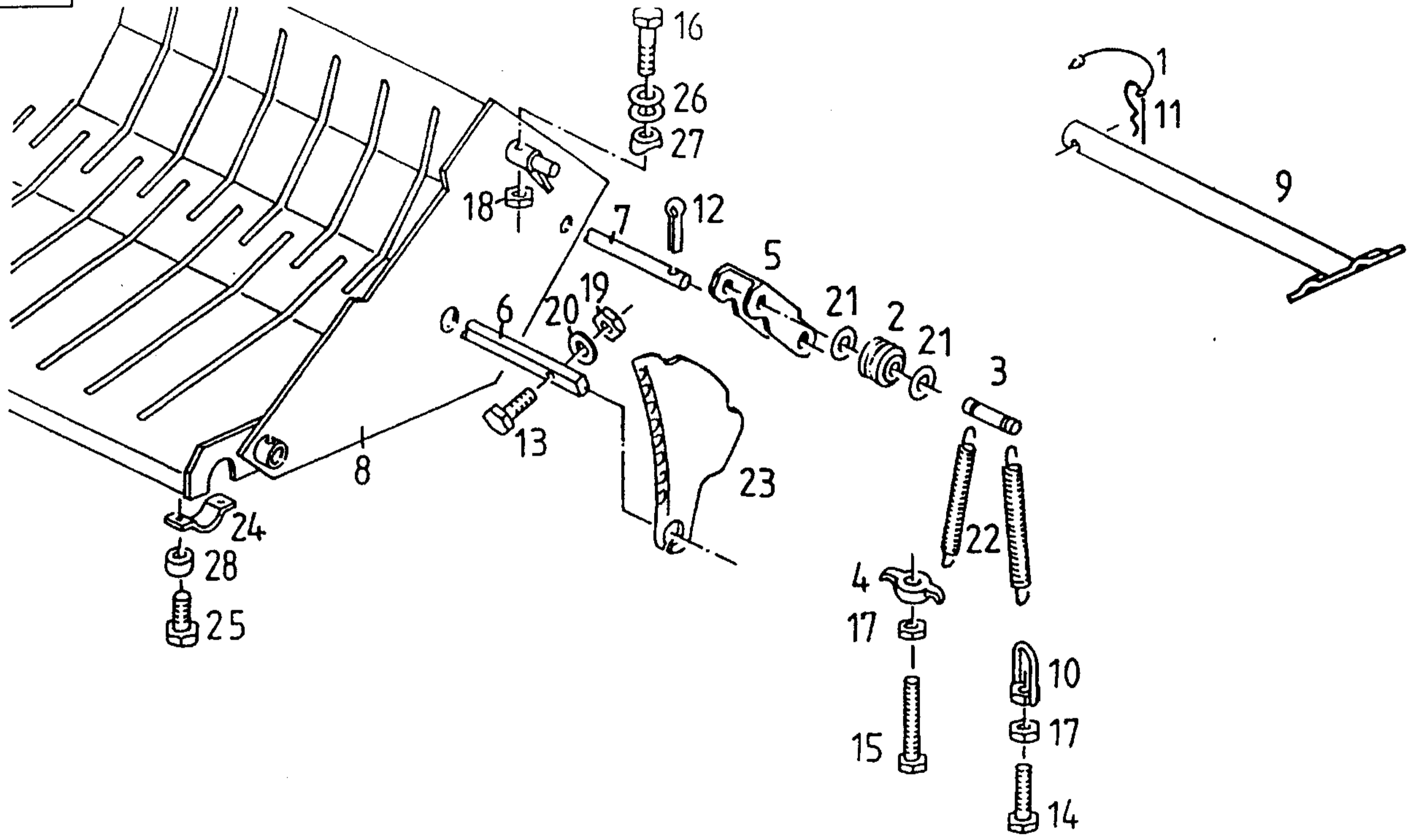

	Schneidwerk		cutting device		disp.de coupe		disp.de corte
Pos.	Teile-Nr.	Menge	Benennung	Description	Designation	Denominacion	
Pos.	Part.Nr.	Qty.					Diagram
Pos.	Piece No.	Qte.					Diagramme
Pos.	Pieza No.	Cat.					Diagrama
							Bemerkungen
							Notes
							Notes
							Notas
1	0656 4448	1	Schnur	CORD	CORDE	CORDON	
2	0657 7109	17	ROLLE	ROLLER	ROULEAU	RODILLO	
G	0657 7110	17	Rollenbolzen	PIN	GOUJON	PERNO	
4	0657 7111	16	SPANNSTUECK	TIGHTENING PLATE	PLAQUE DE SERRAGE	PIEZA TENSORA	
5	0657 7442	17	BUEGEL	YOKE	ETRIER	ESTRIBO	
6	1651 1G36	1	Messerachse oben	AXLE	ESSIEU	EJE	
7	0657 758G	1	LOCHACHSE OBEN	AXLE	AXE	EJE	
8	0657 1172	1	SCHNEIDVORRICHTUNG	CUTTING DEVICE	JEU DE LAMES	JUEGO DE HOJAS	
9	0657 1297	1	Ausrückhebel gsw.	RELEASE LEVER	LEVIER DEBRAYEUR	PALANCA DESEMBRAG	
10	0657 7496	2	BUEGELMUTTER	NUT	ECROU	TUERCA	
11	0626 4206	1	Federstecker 2,5 A3C	SPRING	RESSORT	RESORTE	
12	0110 6451	18	Splint 4 x 25 A3C	SPLIT PIN	GOUPILLE FENDUE	PASADOR DE ALETAS	
13	0111 24G9	16	S R.M10x35 D933	HEX. HEAD SCREW	VIS TETE 6-PANS	TORN.CAB. HEXAGONAL	
14	0111 2451	2	Shr.M10x 45D933	HEX. HEAD SCREW	VIS A TETE 6-PANS	TORNILLO HEX.	
15	0111 2476	16	SHR.MIOX 90D933	HEX. HEAD SCREW	VIS TETE 6-PANS	TORNILLO HEX.	
16	0111 1522	2	SHR.M12X 70D931	HEX. BOLT	VIS 6 PANS	TORNILLO HEXAGONAL	
17	0110 2659	18	Mutter M 10 D934-	HEX. NUT	ECROU 6-PANS	TUERCA HEXAGONAL	
18	0620 9769	2	Mu. M i2 8A3C	Lock nut	Ecrou de securite	Tuerca de se uridad	
19	0620 9768	16	Sich.-Mutter M10 A3C	LOCK NUT	ECROU DE SECURITE	TUERCA DE SEGURIDAD	
20	0112 75G8	16	Shb. 10,5 DIN 7G49	WASHER	RONDELLE	ARANDELA	
21	0621 4206	34	Scheibe 13x30x4	WASHER	RONDELLE	ARANDELA	
22	0621 5561	G4	Zugfeder 4,5x20x180	TENSION SPRING	RESSORT DE RAPPEL	RESORTE DE TENSION	
23	0627 8720	11	Sc hneidmesser	KNIFE	COUTEAU	SECCION	
24	0657 8892	2	BUEGEL	YOKE/RETAINER	ETRIER	ESTRIBO	
25	0117 7466	4	SHR. H2091 DIN 93G	HEX.BOLT	VIS 6 PANS	TORNILLO HEXAGONAL	
26	0621 4207	10	Scheibe 13x24x2,5A3C	WASHER	RONDELLE	ARANDELA	
27	0658 6971	4	SCHEIBE	WASHER	RONDELLE	ARANDELA	
28	0656 2016	4	ABSTANDRING	WASHER	RONDELLE D'EPAISSEUR	ANILLO DISTANCIADOR	

Bildtafel P01

Diagram

Diagramme

Diagrama

Bemerkungen

Notes

Notes

Notas

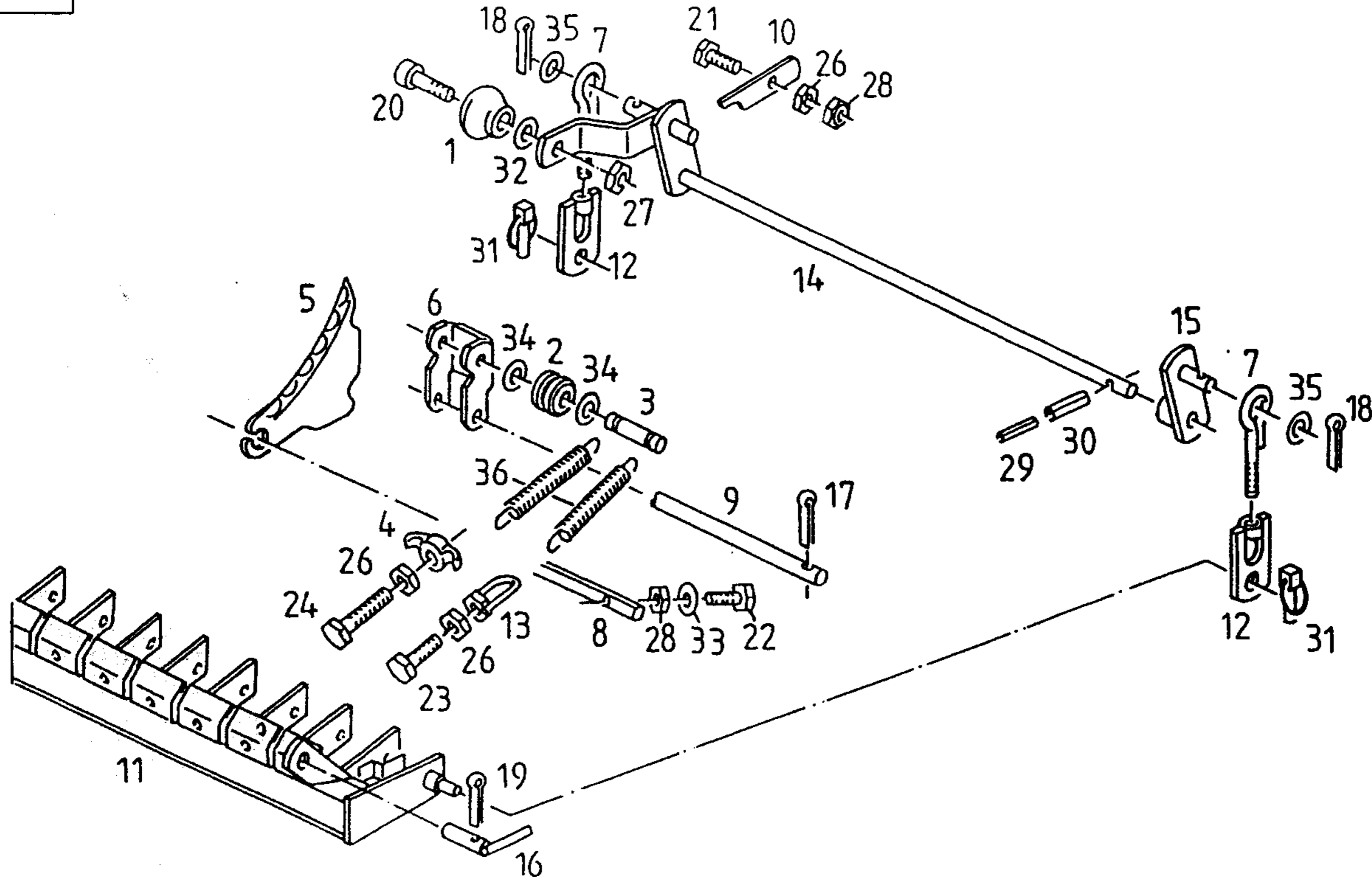

Pos.	Teile-Nr.	Menge	Benennung	Description	Designation	Denomination
Pos.	Part.-Nr.	Qty				
Pos.	Piece No.	Qte				
Pos.	Pieza No.	Cat				
1	0624 3750	1	KURBELKNOPF	BALL	POIGNEE	EMPUNADURA
2	0657 7109	16	ROLLE	ROLLER	ROULEAU	RODILLO
3	0657 7110	16	Rollenbolzen	PIN	GOUJON	PERNO
4	0657 7111	15	SPANNSTUECK	TIGHTENING PLATE	PLAQUE DE SERRAGE	PIEZA TENSORA
5	0627 8720	16	Schneidmesser	KNIFE	COUTEAU	SECCION
6	0657 7442	16	BUEGEL	YOKE	ETRIER	ESTRIBO
7	0657 7483	2	Osenschraube	EYEBOLT	BOULON A OEIL	TORNILLO CON OJETE
8	1651 1337	1	Messerachse unten	AXLE	ESSIEU	EJE
9	0657 7586	1	LOCHACHSE UNT.	AXLE	AXE	EJE
10	0657 7489	1	FLACHRIEGEL	FLAT CATCH	VERROU PLAT	CERROJO PLANA
11	0657 1186	1	MESSERTRAEGER	SUPPORT	SUPPORT	SOPORTE
12	0657 7494	2	ZUGGLASCHE CESCHW.	TRACTION EYE	ECLISSE DE TRACTION	ECLISA DE TIRO
13	0657 7496	2	BUEGELMUTTER	NUT	ECROU	TUERCA
14	0657 0195	1	Drehstab gsw.	torsion rod	barre de torsion	barra torsion
15	0657 0185	1	HEBEL GESCHW.	LEVER	LEVIER	PALANCA
16	0657 7498	2	STECKBOLZEN GESCHW.	FIXING PIN	BROCHE	PASADOR
17	0110 6451	16	Splint 4 x 25 A3C	SPLIT PIN	GOUPILLE FENDUE	PASADOR DE ALETAS
18	0112 2072	2	Splint 5x32 D94 A3C	SPLIT PIN	GOUPILLE FENDUE	PASADOR ALETAS
19	0114 3009	2	Splint 6,3 x 50	SPLIT PIN	GOUPILLE FENDUE	PASADOR ALETAS
20	0110 1405	1	Shr.M 8X 50D912	SCREW	vis	TORNILLO
21	0111 2429	1	Shr. M 10x30 88A3C	HEX. HEAD SCREW	VIS TETE 6-PANS	TORN.CAB. HEXAGONAL
22	0111 2439	15	SHR.M10x35 D933	HEX. HEAD SCREW	VIS TETE 6-PANS	TORN.CAB. HEXAGONAL
23	0111 2451	2	Shr.M10x 45D933	HEX. HEAD SCREW	VIS A TETE 6-PANS	TORNILLO HEX.
24	0111 2476	15	SHR.M10X 90D 933	HEX. HEAD SCREW	VIS TETE 6-PANS	TORNILLO HEX.
26	0110 2659	18	Mutter M 10 D934-	HEX. NUT	ECROU 6-PANS	TUERCA HEXAGONAL
27	0110 4944	1	Sich. Mu. M8 8A3C	LOCK NUT	ECROU DE SECURITE	TUERCA DE SEGURIDAD
28	0620 9768	16	Sich.-Mutter M10 A3C	LOCK. NUT	ECROU DE SECURITE	TUERCA DE SEGURIDAD
29	0115 7344	1	Sp.Stift 6x40 D1481	DOWEL PIN	GOUPILLE SERRAGE	PERNO FIADOR
30	0113 8412	1	Spannstift 10x40 A3C	DOWEL PIN	GOUPILLE SERRAGE	PERNO PIADOR
31	0112 6332	2	KLST.6 D11023 ST502	DOWEL PIN	BROCHE	PERNO DE FIJACION
32	0113 8374	1	Scheibe 8,4 A3C	WASHER	RONDELLE	ARANDELA
33	0110 7165	15	Scheibe 11,0 A3C	WASHER	RONDELLE	ARANDELA
34	0621 4206	32	Scheibe 13x30x4	WASHER	RONDELLE	ARANDELA
35	0621 4226	2	Schb. 21,0 D125 A3C	WASHER	RONDELLE	ARANDELA
36	0621 5561	32	Zugfeder 4,5x20x180	TENSION SPRING	RESSORT DE RAPPEL	RESORTE DE TENSION

Bildtafel P02

Diagram
Diagramme
Diagrama
Bemerkungen
Notes
Notes
Notas

U 01

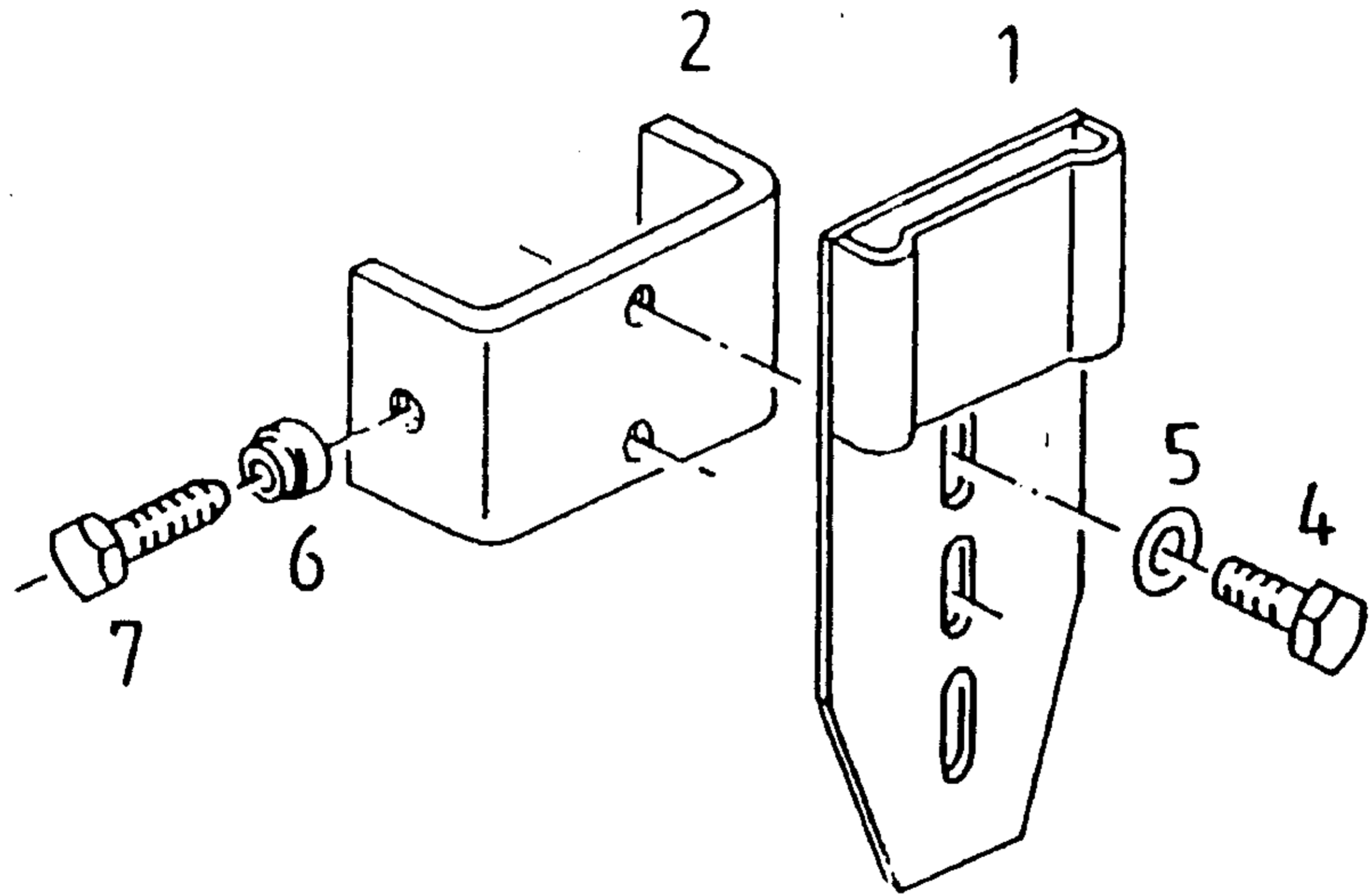

Armaturenkonsole
für Fernbedienung

instrument board
for télé command.

tablier d.instruments
pour télécommandé

tablero instrumentos
para telemando

Bildtafel U01

Diagram
Diagramme
Diagrama
Bemerkungen
Notés
Notés
Notas

Pos.	Teile-Nr.	Menge	Benennung	Description	Désignation	Denominacion	
Pos.	Part.Nr.	Qty.					
Pos.	Piece No.	Qte.					
Pos.	Pieza No.	Cat.					
1	0657 0724	1	Halter geschw.	SUPPORT	SUPPORT	SOPORTE	
2	0657 0740	1	Bügel mont.	YOKE	ETRIER	ESTRIBO	
4	0112 6186	2	Shr. M 10x16 8.8	HEX. HEAD SCREW	VIS TETE 6-PANS	TORN.CAB. HEXAGONAL	
5	0112 7538	2	Shb. 10,5 DIN 7349	WASHER	RONDELLE	ARANDELA	
6	0113 9650	1	Druckstück S25	THRUST PIECE	PIECE DE BUTEE	PIEZA PRES.	X 2
7	0114 2049	1	Druckschraube	PRESSURE SCREW	VIS DE SERRAGE	TORNILLO PRESION	X 2