



Alpex 280

Spare Parts Manual

Article number: MS_1663_3347
Language: EN
Production year (from): 2006
Prod. Series nr (from): 6646
0101 < Mach. ID <=



Alpex 280 / Table of Contents

PosNo.	Assembly group	Page
B	DRIVE	1
B	ANGULAR GEAR	2
B	UNIVERSAL-JOINT SHAFT	3
B	UNIVERSAL-JOINT SHAFT	4
C	BRAKING AXLE HYDRAULIC AND PNEUMATIC ()	5
C	HANDBRAKE PRESS. AIR BRAKE	6
C	BRAKE LEVER SINGLE AXLE (FRANCE)	7
C	PARKING STAND	8
C	SUPPORT WHEEL	9
C	ASSORTMENT OF WHEEL	10
C	BPW TRAILER AXLE	11
D	HYDRAULIC FOR BRAKE DEV. SINGLE AXLE (-0180)	12
D	HYDRAULIC FOR BRAKE DEV. SINGLE AXLE (+0181)	13
D	HYDR. FOR CRANKED DRAWBAR (-0180)	14
D	HYDR. FOR CRANKED DRAWBAR (+0181)	15
D	HYDRAULIS AND DRIVE F. SCRAPER FLOOR	16
D	HYDR. INSTALATION BASIC CONTENT	17
D	HYDR. INSTALATION BASIC CONTENT + OPTIONS	18
D	HYDRAULIC FOR PICK-UP	19
D	HYDRAULIC FOR REAR GATE	20
D	COMPRESSED AIR SYSTEM SINGLE AXLE (ONLY GERMANY)	21
D	HYDRAULIC OPERATION DRY FORAGE	22
D	LUBE SYSTEM DRUM WITH 3 RAKES	23
D	LUBE SYSTEM DRUM WITH 4 RAKES	24
E	GREEN FODDER SUPERSTRUCTURE, SUPPORTS	25
E	GREEN FODDER SUPERSTRUCTURE - SIDE PANELS	26
E	HYDR. ADJUSTEMENT OF BACK NET UNIT	27
E	DRY FORAGE SUPERSTRUCTURE	28
E	DRY FORAGE SUPERSTRUCTURE NET	29

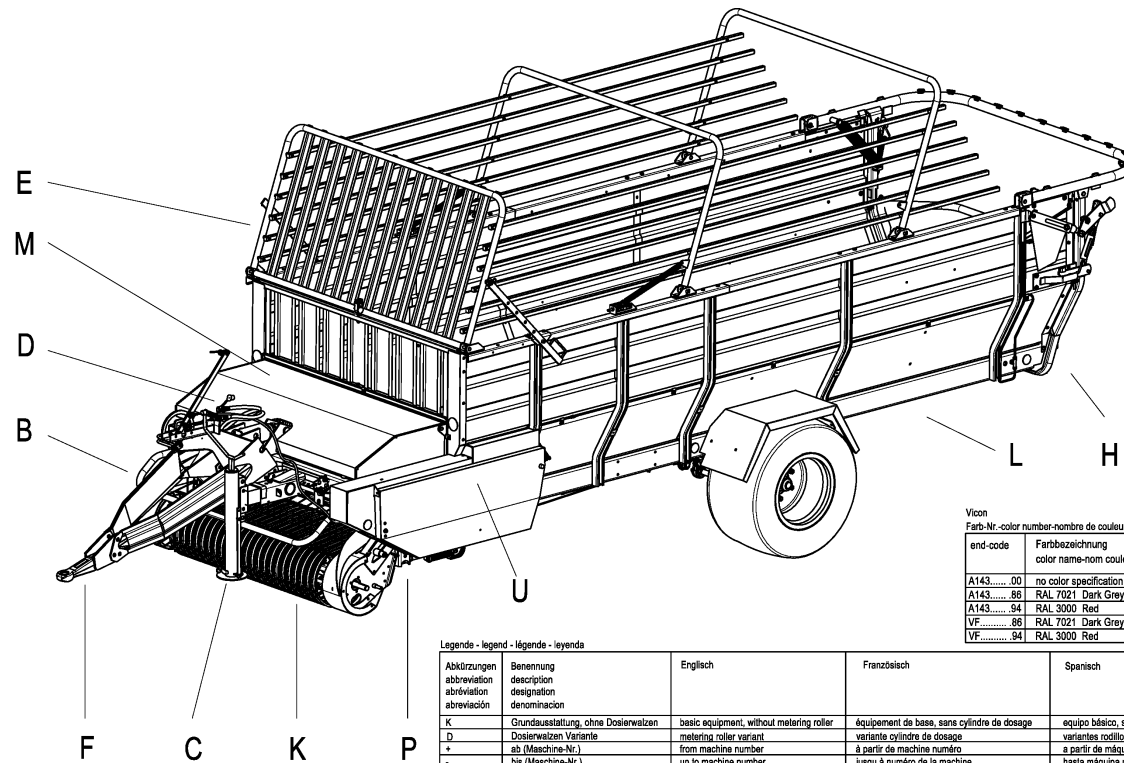

Vicon
Farb-Nr.-color number-nombre de couleurs-numero de color

end-code	Farbbezeichnung color name-nom couleur-nombre del color
A143.....00	no color specification
A143.....86	RAL 7021 Dark Grey
A143.....94	RAL 3000 Red
VF.....86	RAL 7021 Dark Grey
VF.....94	RAL 3000 Red

Legende - legend - légende - leyenda

Abkürzungen abbreviation abréviation abreviación	Benennung description designation denominación	Englisch	Französisch	Spanisch
K	Grundausrüstung, ohne Dosierwalzen	basic equipment, without metering roller	équipement de base, sans cylindre de dosage	equipo básico, sin rodillo dosificación
D	Dosierwalzen Variante	metering roller variant	variante cylindre de dosage	variantes rodillo dosificación
+	ab (Maschine-Nr.)	from machine number	à partir de machine numéro	à partir de máquina número
-	bis (Maschine-Nr.)	up to machine number	jusqu'à numéro de la machine	hasta máquina número
+A	ab Baujahr	from year of construction	à partir de l'année de construction	desde el año de construcción
-A	bis Baujahr	to year of construction	jusqu'à l'année de construction	hasta el año de construcción
E	ersetzt	replaced	remplacé	sustituye
V	Ausstattungsvariante	option	variante	variante
X	gehört zu Pos.Nr.	belongs to pos.no.	fait partie de pos.no.	forma parte de pos.no.
S	siehe Seite	see page	voir page no.	véase en página
b	besteht aus	consist of	se composer de	consistente en



Alpex 280 / Table of Contents

PosNo.	Assembly group	Page
E	AND CORD (-A 2007)	
E	DRY FORAGE SUPERSTRUCTURE NET AND CORD (+A 2008)	30
F	DRAWBAR Z 400 (-0180)	31
F	DRAWBAR Z 450 (+0181)	32
F	DRAWBAR Z 800 (-0180)	33
F	DRAWBAR Z 800 (+0181)	34
F	SPINDLE (-0180)	35
F	SPINDLE (+0181)	36
F	OVERR. DRAWBAR	37
F	OVERRUNNING DEVICE AVEG 2000 BPW	38
H	ELECTRICAL CONTROLLER ()	39
H	DISTRIBUTION BOX	40
H	ELECTR.EQUIPMENT LIGHTING	41
H	ELECTR.EQUIPMENT LIGHTING	42
K	PICK-UP 1.6 SCRAPER	43
K	PICK-UP 1.6 DRUM	44
K	PICK-UP 1.6 BAFFLE PLATE	45
K	PICK-UP 1.6 TACTILE WHEEL	
K	PNEUMATIC TIRE	46
K	PICK-UP 1.6 BAFFLE PLATE WITH ROLE	47
K	PICK-UP 1.8 DRUM	48
K	PICK-UP 1.8 SCRAPER	49
K	PICK-UP 1.8 TACTILE WHEEL	
K	PNEUMATIC TIRE	50
K	PICK-UP 1.8 BAFFLE PLATE WITH ROLE	51
L	SCRAPER FLOOR BOARDS	52
L	SCRAPER FLOOR	53
L	DRUM ELEVATOR GRATE	54
L	DRUM ELEVATOR SIDE PANELS	55
L	DRUM ELEVATOR DRUM 4- RAKE	56
L	DRUM ELEVATOR DRUM 3- RAKE	57
L	DRUM ELEVATOR CRANK WITH BEARING 4-RAKE	58
L	DRUM ELEVATOR CRANK WITH BEARING 3-RAKE	59
L	DRUM ELEVATOR PINION SHAFT	60
L	DRUM ELEVATOR RELEASE LEVER	61
M	PROTECTIVE COVERING	62

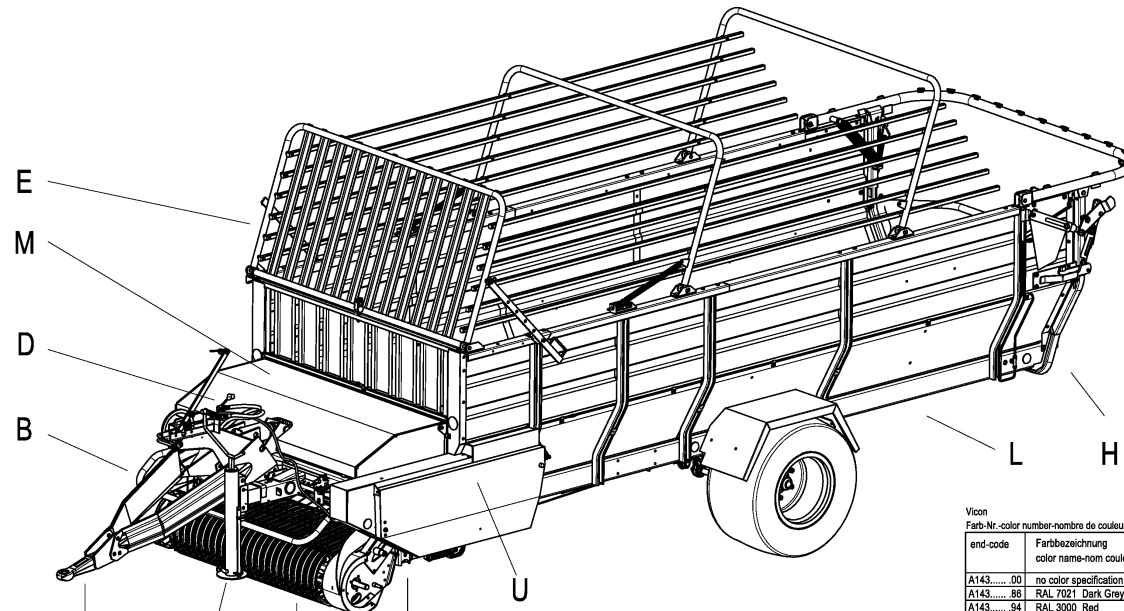

Vicon
 Farb-Nr.-color number-nombre de couleurs-numero de color

end-code	Farbbezeichnung color name-nom couleur-nombre del color
A143.....00	no color specification
A143.....86	RAL 7021 Dark Grey
A143.....94	RAL 3000 Red
VF.....86	RAL 7021 Dark Grey
VF.....94	RAL 3000 Red

Legende - legend - légende - leyenda

Abkürzungen abbreviation abréviation abreviación	Benennung description designation denominación	Englisch	Französisch	Spanisch
K	Grundausstattung, ohne Dosierwalzen	basic equipment, without metering roller	équipement de base, sans cylindre de dosage	equipo básico, sin rodillo dosificación
D	Dosierwalzen Variante	metering roller variant	variante cylindre de dosage	variantes rodillo dosificación
+	ab (Maschine-Nr.)	from machine number	à partir de machine numéro	a partir de máquina número
-	bis (Maschine-Nr.)	up to machine number	jusqu'à numéro de la machine	hasta máquina número
+A	ab Baujahr	from year of construction	à partir de l'année de construction	desde el año de construcción
-A	bis Baujahr	to year of construction	jusqu'à l'année de construction	hasta el año de construcción
E	ersetzt	replaced	remplacé	sustituye
V	Ausstattungsvariante	option	variante	variante
X	gehört zu Pos.Nr.	belongs to pos.no.	fait partie de pos.no.	forma parte de pos.no.
S	siehe Seite	see page	voir page no.	véase en página
b	besteht aus	consist of	se composer de	consistente en

Alpex 280 / Table of Contents



PosNo.	Assembly group	Page
P	EQUIPMENT WITH 4 KNIVES ADJUSTMENT	63
P	DOUBLE-CHOP EQUIPM.	64
U	DECALS (+A 2015)	65
U	WARNING DECAL EU	66

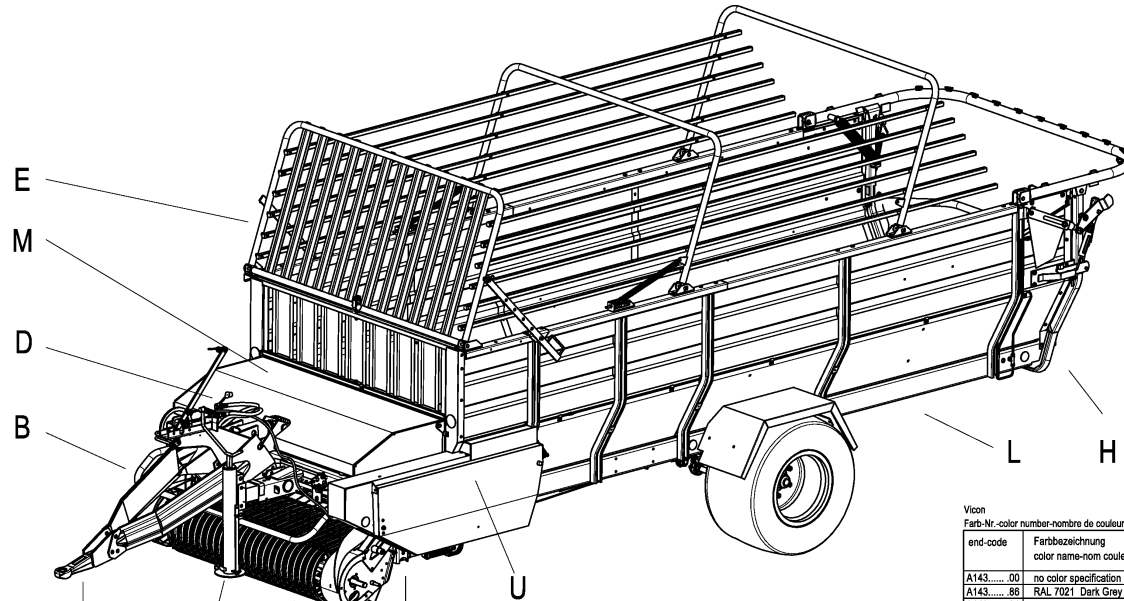

Vicon
Farb-Nr.-color number-nombre de couleurs-numero de color

end-code	Farbbezeichnung color name-nom couleur-nombre del color
A143.....00	no color specification
A143.....86	RAL 7021 Dark Grey
A143.....94	RAL 3000 Red
VF.....86	RAL 7021 Dark Grey
VF.....94	RAL 3000 Red

Legende - legend - légende - leyenda

Abkürzungen abbreviation abreviación abreviación	Benennung description designation denominación	Englisch	Französisch	Spanisch
K	Grundausstattung, ohne Dosierwalzen	basic equipment, without metering roller	équipement de base, sans cylindre de dosage	equipo básico, sin rodillo dosificación
D	Dosierwalzen Variante	metering roller variant	variante cylindre de dosage	variantes rodillo dosificación
+ - +A -A	ab (Maschine-Nr.) bis (Maschine-Nr.) ab Baujahr bis Baujahr	from machine number up to machine number from year of construction to year of construction	à partir de machine numéro jusqu'à numéro de la machine à partir de l'année de construction jusqu'à l'année de construction	à partir de máquina número hasta máquina número desde el año de construcción hasta el año de construcción
E	ersetzt	replaced	remplacé	sustituye
V	Aussetzvariante	option	variante	variante
X	gehört zu Pos.Nr.	belongs to pos.no.	fait partie de pos.no.	forma parte de pos.no.
S	siehe Seite	see page	voir page no.	véase en página
b	besteht aus	consist of	se composer de	consistente en

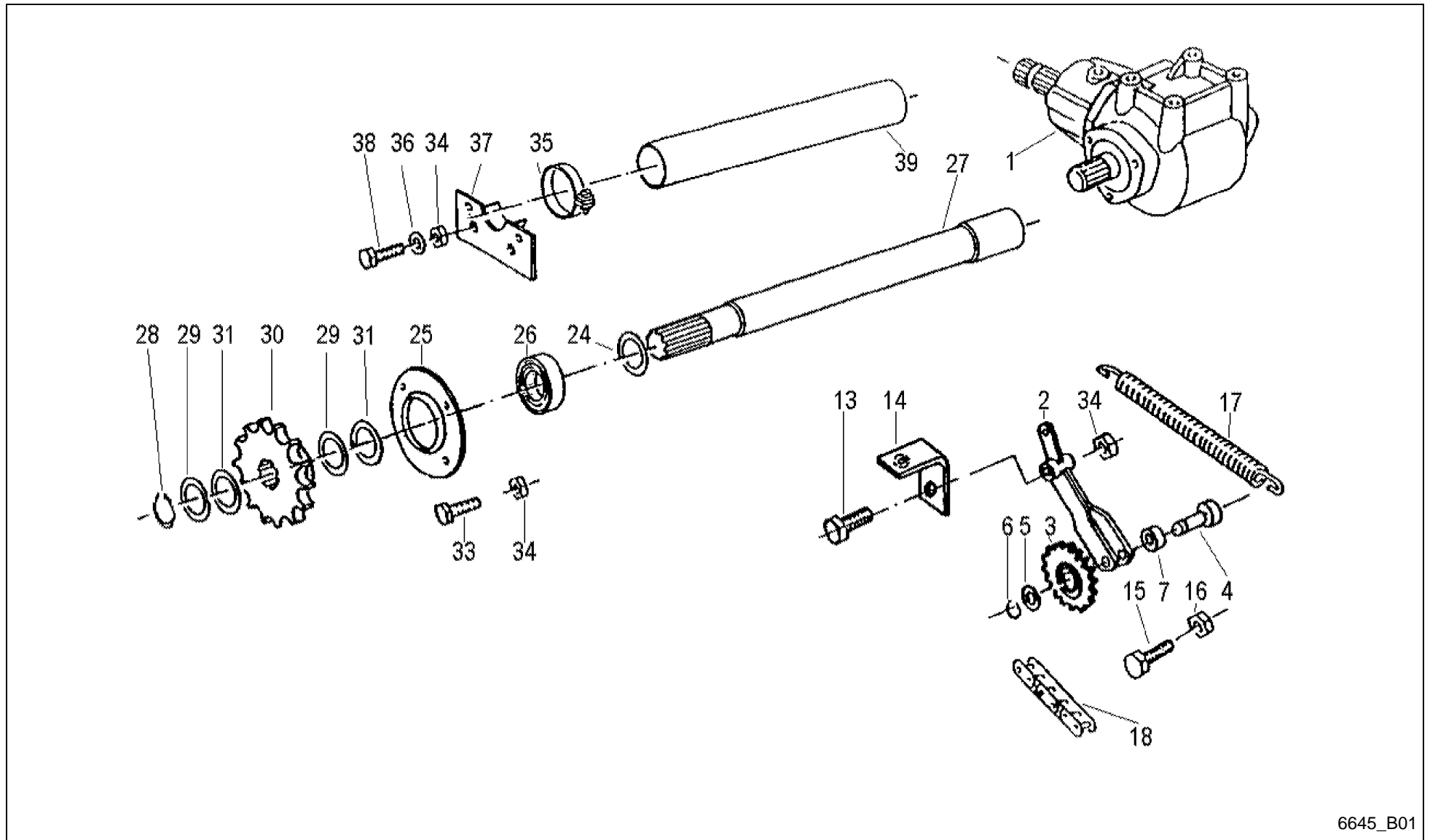

6645_B01

Alpex 280 / DRIVE



PosNo.	Part No.	Qty.	Description	Remark
1	VF16610801	1	ANGLE DRIVE	
2	VF16631263	1	TENSIONER	
3	VF16513217	1	SPROCKET	
4	VF16630655	1	BOLT WELDED	
5	VF06214588	1	SHIM	
6	VF01107737	1	CIRCLIP	
7	VF06580174	2	SPACER	
13	VF01111557	1	HEX.HEAD SCREW	
14	VF16518921	1	ANGLE PLATE	
15	KG00480461	1	HEX. SCREW M16X50 8.8	
16	VF01112886	1	HEX. NUT	
17	VF01142492	1	DRAW SPRING	
18	VF01142993.01	1	ROLLER CHAIN	
24	VF16631182	1	SPACER	
25	VF06215785	1	BEARING FLANGE	
26	VF16614169	1	BALL BEARING	
27	VF16513000	1	DRIVE SHAFT	
28	VF01107755	1	CIRCLIP	
29	VF01137379	6	SHIM 40 X 50 X 2,5 D988-2	
30	VF16513003	1	SPROCKET	
31	VF06214493	3	SPACER 40X50X1 D988	
33	VF01112529	2	HEX.HEAD SCREW	
34	VF06209769	4	LOCK NUT	
35	VF01128272	1	HOSE CLIP	
36	VF06214207	2	WASHER	
37	VF06550405	1	SUPPORT PLATE	
38	VF01112538	2	HEX.HEAD SCREW	
39	VF06556888	1	PROTECTING TUBE	

Alpex 280 / ANGULAR GEAR

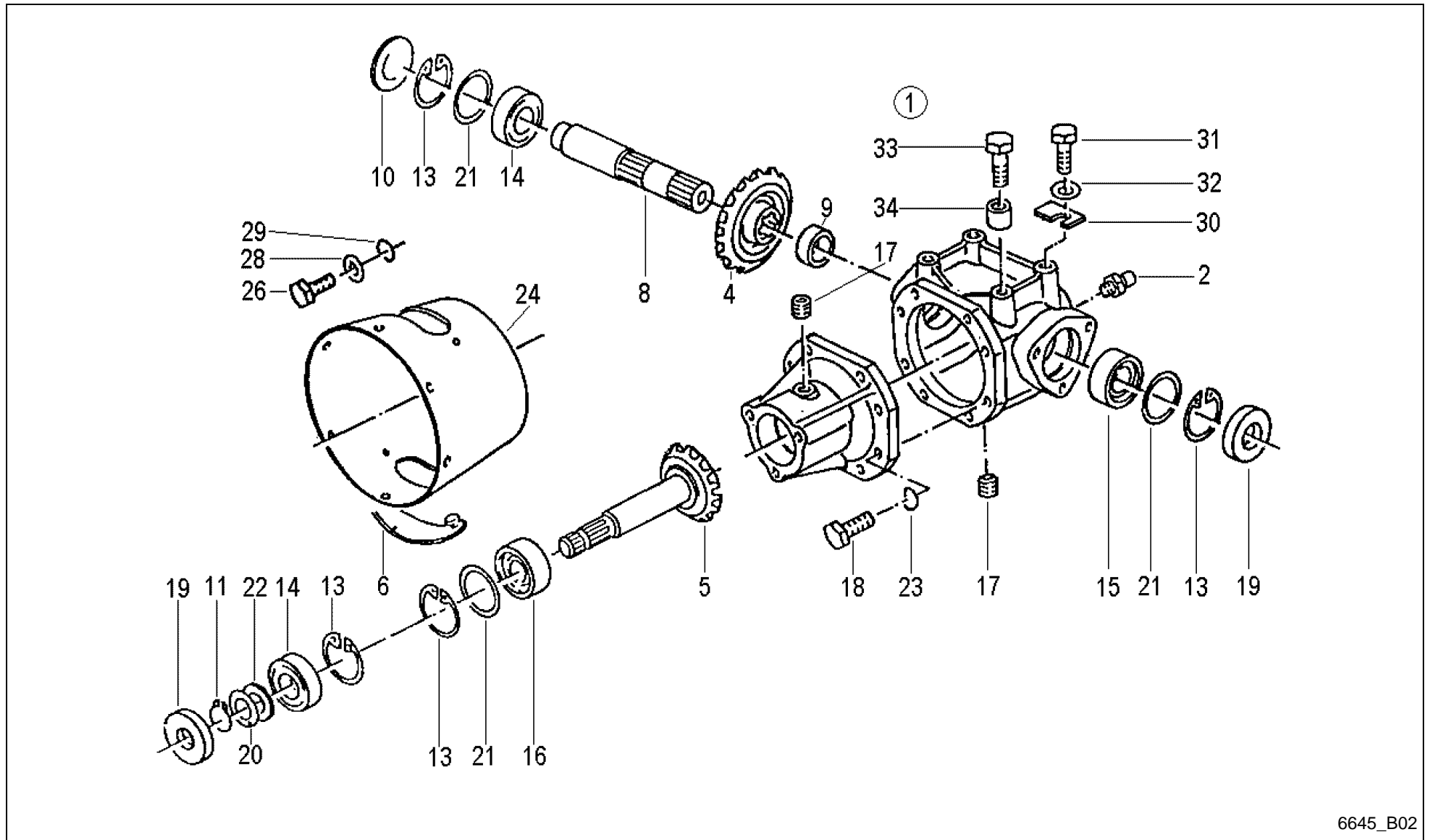

6645_B02



Alpex 280 / ANGULAR GEAR

PosNo.	Part No.	Qty.	Description	Remark
1	VF16610801	1	ANGLE DRIVE	
2	VF06585321	1	VENTING SCREW	
4	VF16611262	1	BEVEL GEAR	
5	VF16611261	1	PINION SHAFT	
6	VF06554188	2	COVER	
8	VF06295430	1	OUTPUT SHAFT	
9	VF11439109110	1	BUSH	
10	VF06557587	1	CAP	
11	VF01137321	1	RING	
13	VF01107855	4	CIRCLIP	
14	VF01109063	2	GROOVE BALL BEARING	
15	VF01109958	1	TAPER R. BEARING	
16	VF01110002	1	TAPER R. BEARING	
17	VF01110415	3	SCREW PLUG	
18	VF01112429	8	HEX. HEAD SCREW	
19	VF01172407	2	RAD.SEAL RING	
20	VF06214490		SPACER	
20.1	VF06214491		SPACER	
20.2	VF06214492		SPACER 40X50X0,5 D988	
20.3	VF01137379		SHIM 40 X 50 X 2,5 D988-2	
21	VF06214521		SPACER	
21.1	VF06214520		SPACER	
21.2	VF06214519		SPACER	
23	VF01102800	8	SPRING WASHER	
24	VF06578978	1	PROTECTING CUP	
26	VF01112307	3	HEX. HEAD SCREW	
28	VF06214246	3	WASHER 9X18X2 GALV.	
29	VF01102799	3	SPRING WASHER	
30	VF06575248		SPACER / SHIM	
30.1	VF06575249		SPACER / SHIM	
30.2	VF06575250		SPACER / SHIM	
31	VF01177810	2	HEX.BOLT	
32	VF01142556	4	SPACING RING	
33	VF01177888	2	HEX.BOLT	
34	VF06575227	2	SPACER RING	

Alpex 280 / UNIVERSAL-JOINT SHAFT

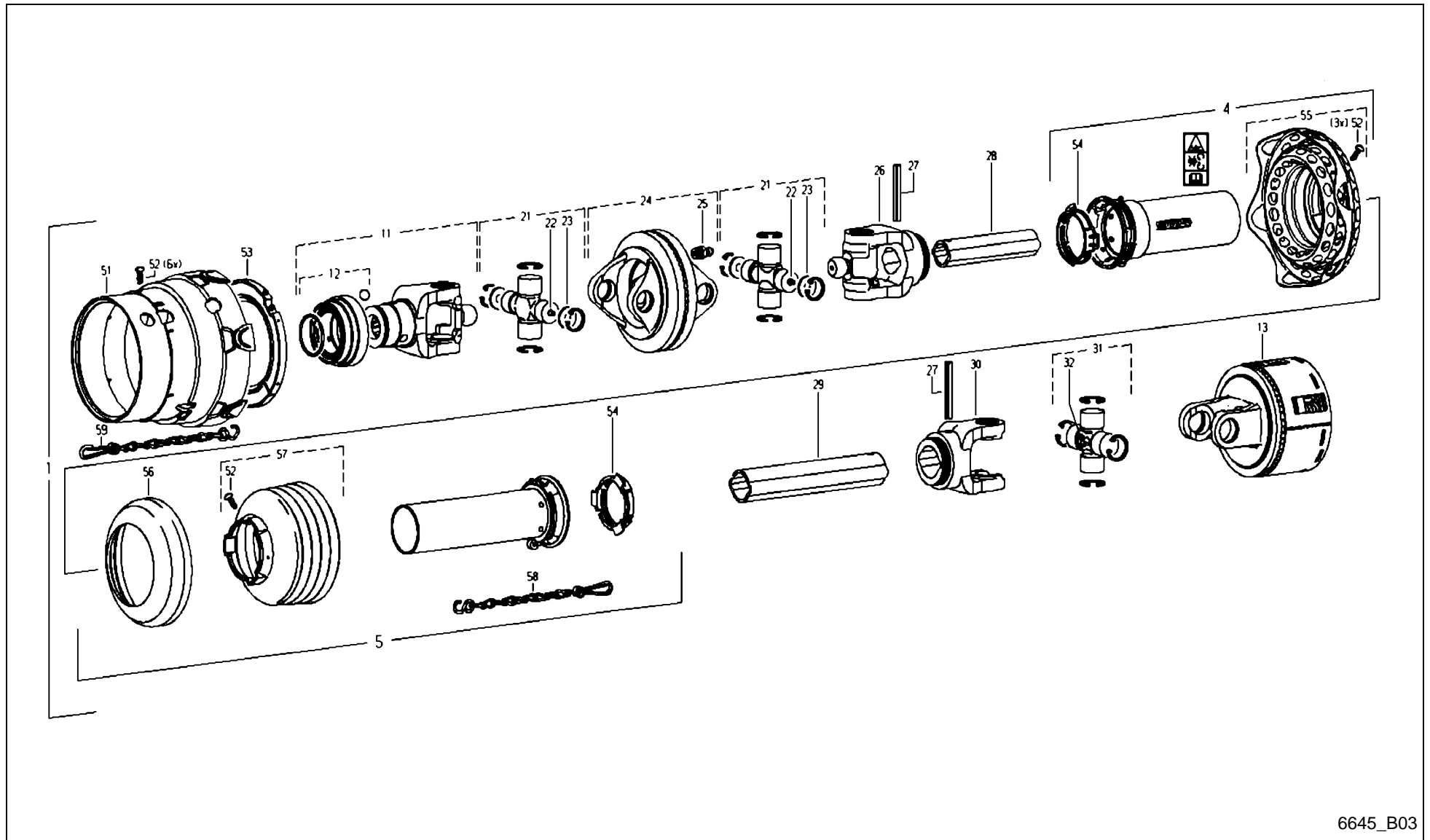

6645_B03



Alpex 280 / UNIVERSAL-JOINT SHAFT

PosNo.	Part No.	Qty.	Description	Remark
1	VF16518241	1	JOINT SHAFT	
4	WA116565	1	OUTER GUARD HALF	
5	WA116192	1	INNER GUARD HALF BLACK	
11	VF16611252	1	QS-FORK KPL.	
12	VF06586171	1	FASTENER/LOCK	
13	A143502100	1	CLUTCH/COUPLING	
21	WA135075	2	CROSS AND BEARING KIT 2480	
22	WA153207	2	GREASE NIPPLE	
23	VG35.06.70	4	DISC	
24	VF06586755	1	DOUBLE YOKE	
25	VG63.12.01	1	GREASE NIPPLE AM8X1-DIN71412	
26	VF06582340	1	FORK	
27	KG01194500	2	TENSION PIN 10X80	
28	WA135895	1	PROFILE TUBE	
29	WA135897	1	PROFILE TUBE	
30	VF06582181	1	INBOARD YOKE RG2400-2A	
31	VF06582182	1	CROSS AND BEARING KIT COMPLETE	
32	VF16504065	1	GREASE NIPPLE BM8X1	
51	WA129948	1	GUARD CONE SDF25-2480 BLACK	
52	KG00742063	10	TAPPING SCREW 3.5X9.5 4.8	
53	VF16513616	1	SLIDING RING	
54	VF06581954	2	BEARING RING	
55	VF16625105	1	GUARD	
56	VF06557740	1	SUPPORT RING	
57	WA377342	1	GUARD CONE BLACK RP12	
58	VF16504077	1	CHAIN 400MM FE/ZN12 GALV.	
59	VF16513618	1	CHAIN 600MM	

Alpex 280 / UNIVERSAL-JOINT SHAFT

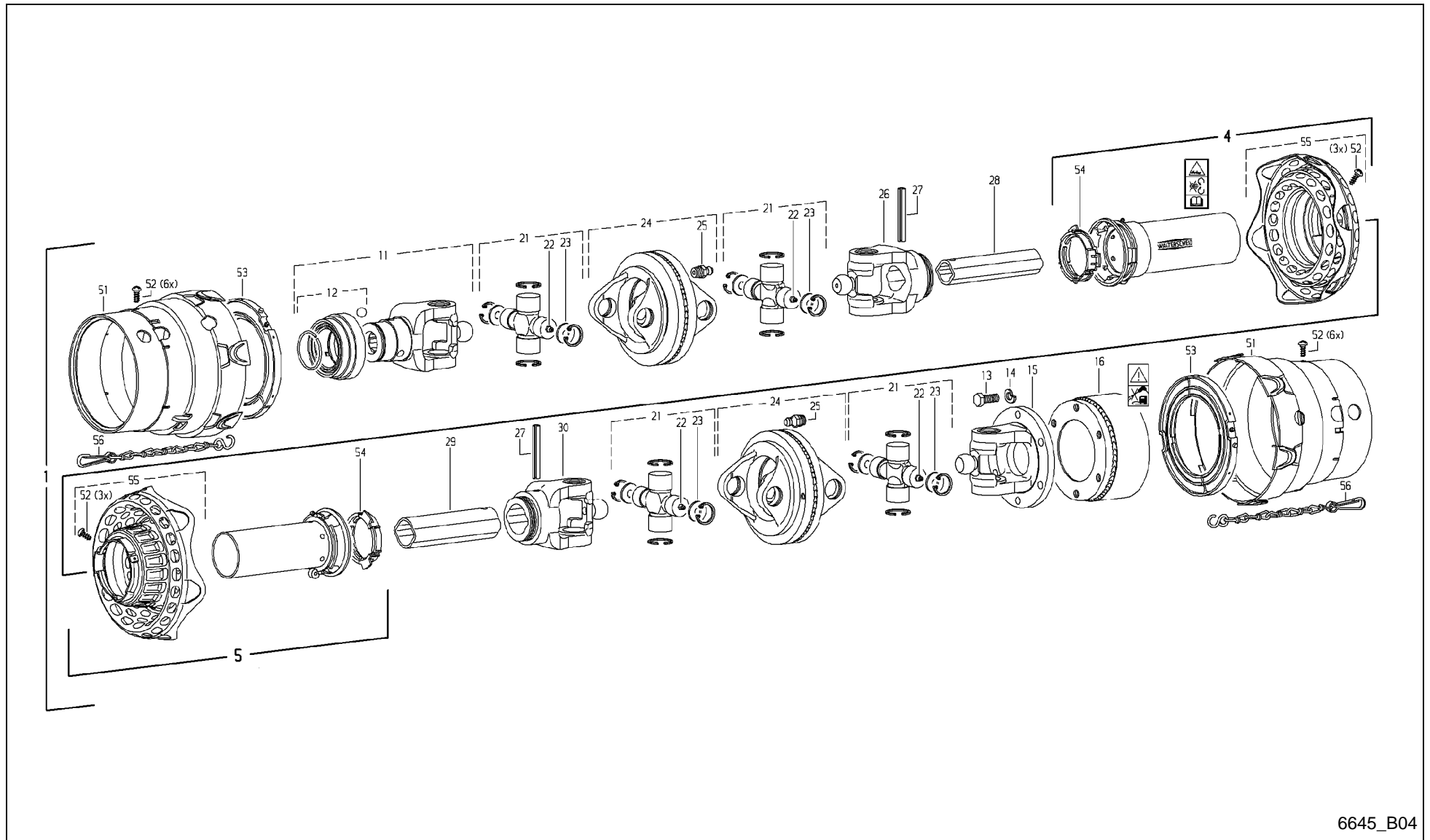

6645_B04



Alpex 280 / UNIVERSAL-JOINT SHAFT

PosNo.	Part No.	Qty.	Description	Remark
1	VF16518245	1	UNIV PROP SHAFT	
4	VF16625120	1	PROTECTION HALF	
5	VF16625114	1	PROTECTION HALF	
11	VF16611252	1	QS-FORK KPL.	
12	VF06586171	1	FASTENER/LOCK	
13	KG00476561	6	HEX. SCREW M12X30 8.8	
14	A100000300	6	SPRING WASHER DIN127-A12	
15	VF16513601	1	FLANGED FORK	
16	A143502000	1	CLUTCH 1500NM	
21	WA135075	4	CROSS AND BEARING KIT 2480	
22	WA153207	4	GREASE NIPPLE	
23	VG35.06.70	8	DISC	
24	VF06586755	2	DOUBLE YOKE	
25	VG63.12.01	2	GREASE NIPPLE AM8X1-DIN71412	
26	VF06582340	1	FORK	
27	KG01194500	2	TENSION PIN 10X80	
28	WA135895	1	PROFILE TUBE	
29	WA135897	1	PROFILE TUBE	
30	VF16513605	1	FORK	
51	VG85.01.02	2	GUARD	
52	KG00742063	18	TAPPING SCREW 3.5X9.5 4.8	
53	VF16513616	2	SLIDING RING	
54	VF06581954	2	BEARING RING	
55	VF16625105	2	GUARD	
56	VF16513618	1	CHAIN 600MM	

Alpex 280 / BRAKING AXLE HYDRAULIC AND PNEUMATIC ()

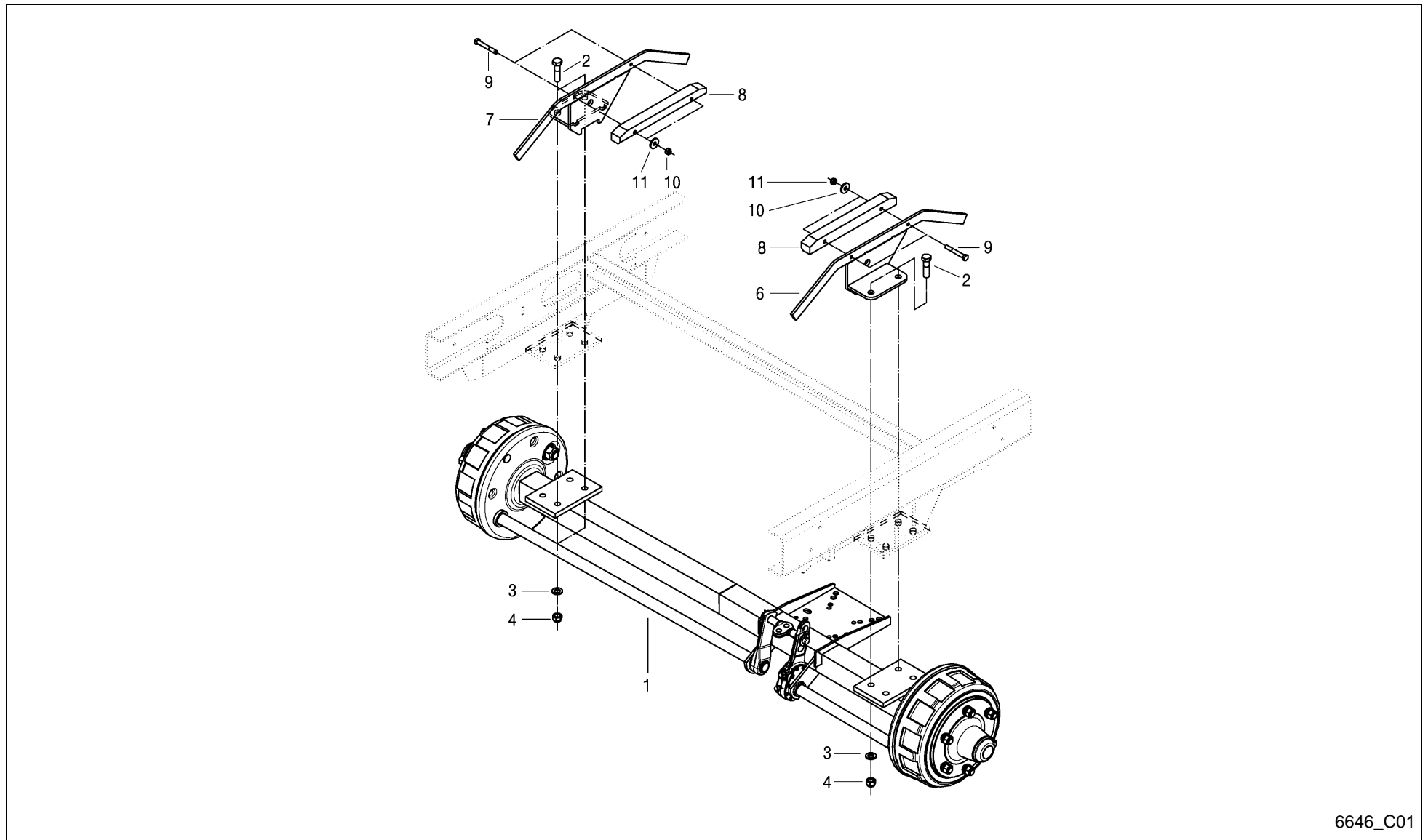

6646_C01

Alpex 280 / BRAKING AXLE HYDRAULIC AND PNEUMATIC ()



PosNo.	Part No.	Qty.	Description	Remark
1	VF16631786	1	BRAKING AXLE 6 TONS	S C10
2	VF01111867	8	HEX.BOLT	
3	VF06214295	8	WASHER 17,0X34,0X3,0 DIN 134	
4	VF01100590	8	LOCK NUT	
6	VF16631898	1	YOKE LEFT	
7	VF16631899	1	YOKE RIGHT	
8	VF16518865	2	STRAP	
9	VF01111168	4	HEX. HEAD SCREW	
10	VF06214192	4	WASHER 8,4X25X3 GALV.	
11	VF01104944	4	NY LOCK NUT 8A3CD985	

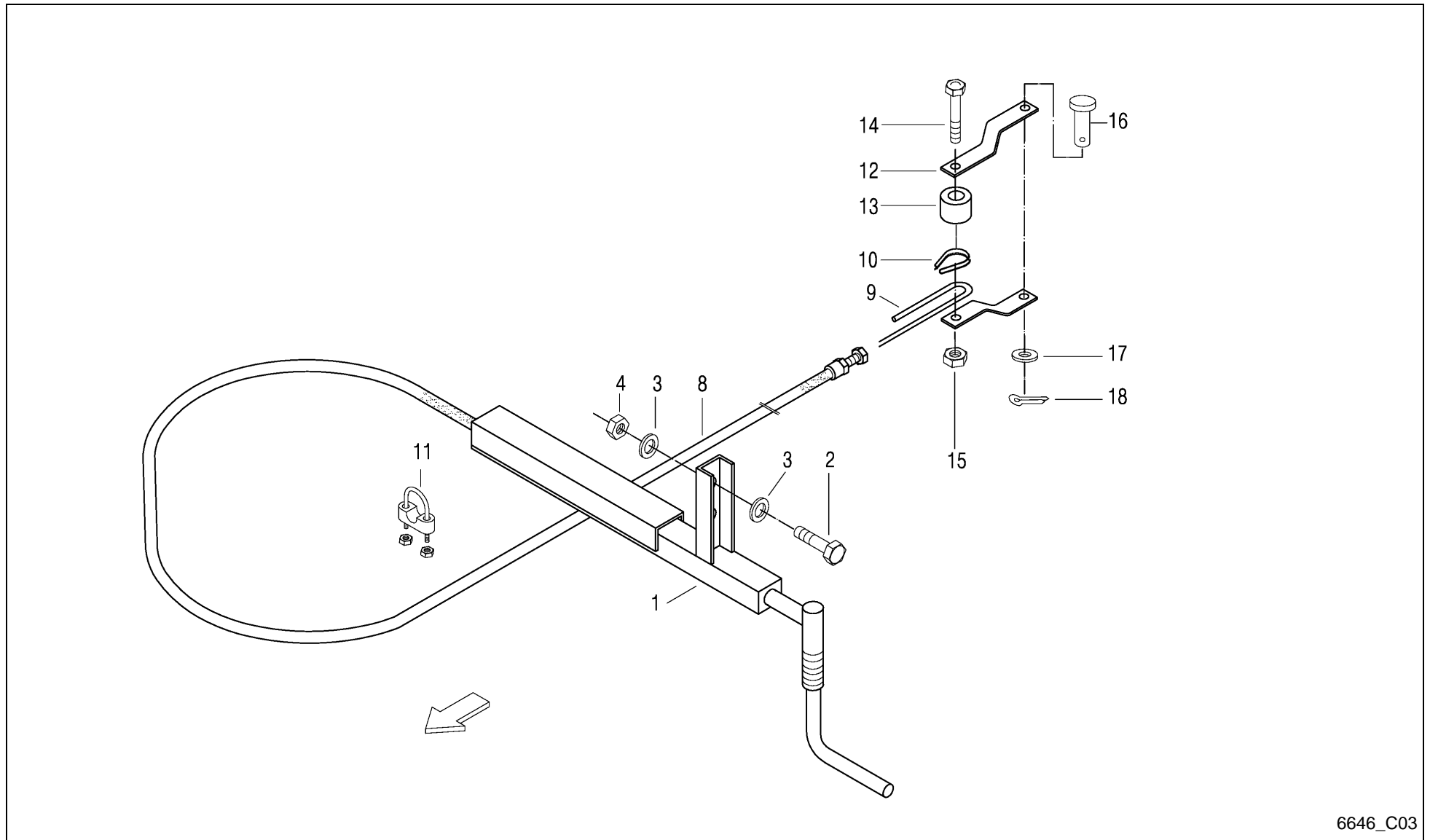

6646_C03

Alpex 280 / HANDBRAKE PRESS. AIR BRAKE



PosNo.	Part No.	Qty.	Description	Remark
1	VF16631721	1	PARK BRAKE LEVER WELDED	
2	VF01112529	2	HEX.HEAD SCREW	
3	VF06214207	4	WASHER	
4	VF06209769	2	LOCK NUT	
8	VF16630488	1	BOWDEN WIRE 1450 MM	
9	VF16518259	1	BRAKE CABLE	
10	VF01139169	1	THIMBLE B 5 DIN6899- GALV.	
11	VF01136686	2	CABEL CLAMP S 5 DIN1142- GALV.	
12	VF16513860	2	LASCHE	
13	VF16513861	1	BUSH	
14	VF01112429	1	HEX. HEAD SCREW	
15	VF06209768	1	LOCK NUT	
16	VF01397843	1	PIN/BOLT/STUD	
17	VF06214202	1	WASHER 14X24X1,6 GALV.	
18	VF01106451	1	SPLIT PIN	

Alpex 280 / BRAKE LEVER SINGLE AXLE (FRANCE)

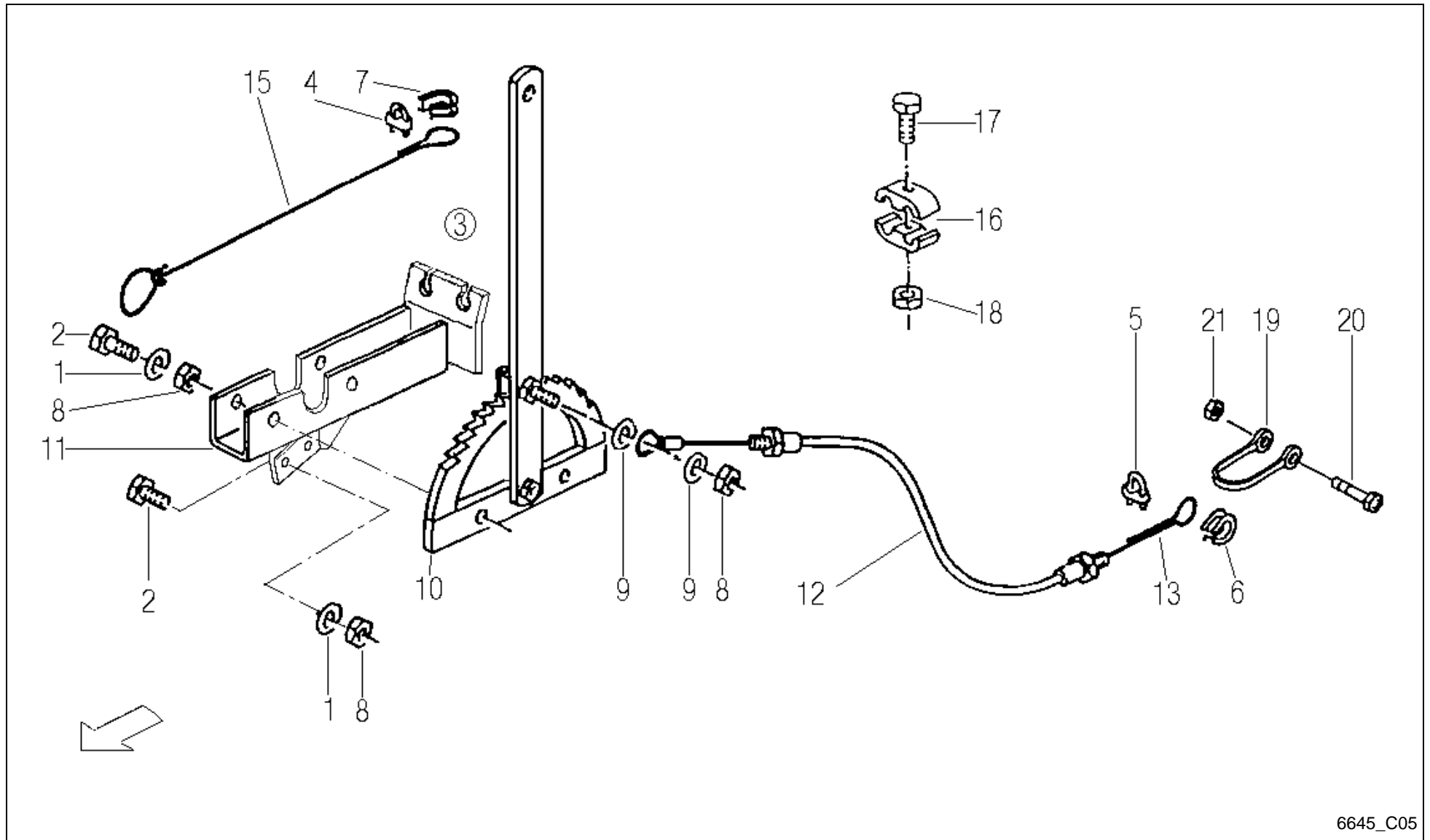

6645_C05



Alpex 280 / BRAKE LEVER SINGLE AXLE (FRANCE)

PosNo.	Part No.	Qty.	Description	Remark
1	VF01107165	2	WASHER M10 11X20X2 A2C DIN126	X 3
2	VF01112439	2	HEX. HEAD SCREW	X 3
3	VF06559137	1	HAND BRAKE LEVER - PREASSEMBLED	
4	VF01136687	1	CLAMPING PIECE	
5	VF01136686	3	CABEL CLAMP S 5 DIN1142- GALV.	
6	VF01139169	1	THIMBLE B 5 DIN6899- GALV.	
7	VF01137837	1	THIMBLE	
8	VF06209768	5	LOCK NUT	X 3
9	VF06214197	2	WASHER 10,5X30X3 GALV.	
10	VF06558706	1	HAND BRAKE LEVER	X 3
11	VF06558708	1	BRACKET	X 3
12	VF16631681	1	ROPE COVER (BRAKE)	
13	VF06558728	1	BRAKE CABLE	
15	VF06587631	1	CABLE	
16	VF06578035	1	CLAMP	
17	VF01111071	1	HEX. HEAD SCREW	
18	VF01114357	1	LOCK NUT	
19	VF01121829	1	SHACKLE	
20	VF01111504	1	SCREW	
21	VF06209769	1	LOCK NUT	

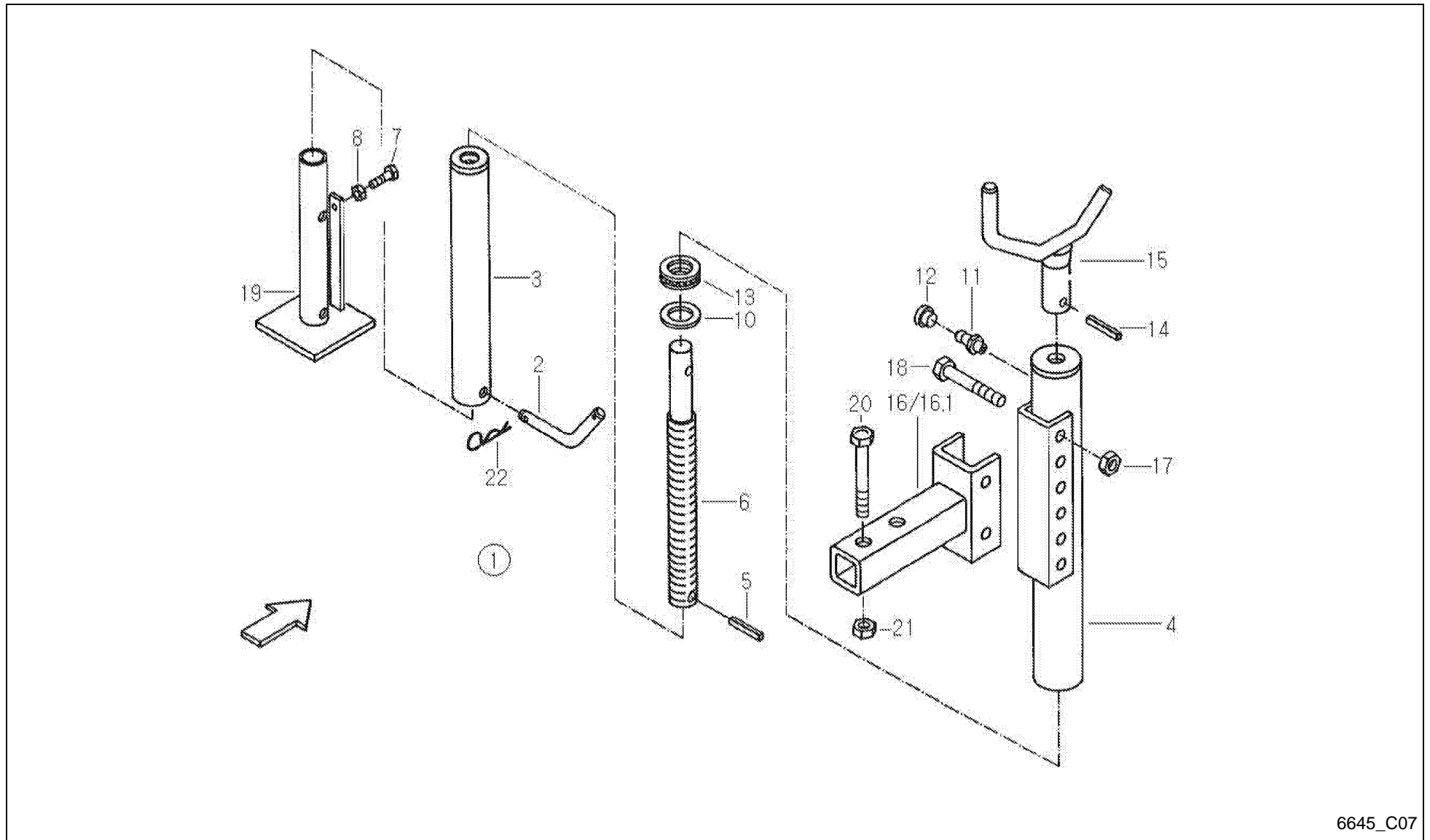

6645_C07



Alpex 280 / PARKING STAND

PosNo.	Part No.	Qty.	Description	Remark
1	VF16613267	1	PRASED PARTS	
2	VF16614473	1	BOLT	
3	VF16614474	1	INNER TUBE	
4	VF16614475	1	EXTERNAL TUBE	
5	KG01185862	2	TENSION PIN 4X16	
6	VF16614480	1	SPINDLE	
7	VF01112307	1	HEX. HEAD SCREW	
8	VF01112824	1	HEX. NUT	
10	VF01141047	1	WASHER 21,0X44,0X5,0	
11	VF01120693	1	GREASE FITTING H1 AM 8X1 DIN 71412	
12	VF16514101	1	PLUG	
13	VF01109886	1	GR. BALL BEARING	
14	VF01115457	1	DOWEL PIN	
15	VF16614479	1	CRANK HANDLE	
16	VF16614478	1	RETAINER	
16.1	VF16631486	1	RETAINER	+A 2007
17	VF06209774	2	LOCK NUT	
18	VF01139339	2	HEX.BOLT	
19	VF16614472	1	SUPPORT	
20	VF16630548	1	HEXAGON HEAD SCREW M16X130 D931 10.9	
21	VF01127856	1	LOCK NUT	
22	VF06215671	1	PIN	

Alpex 280 / SUPPORT WHEEL

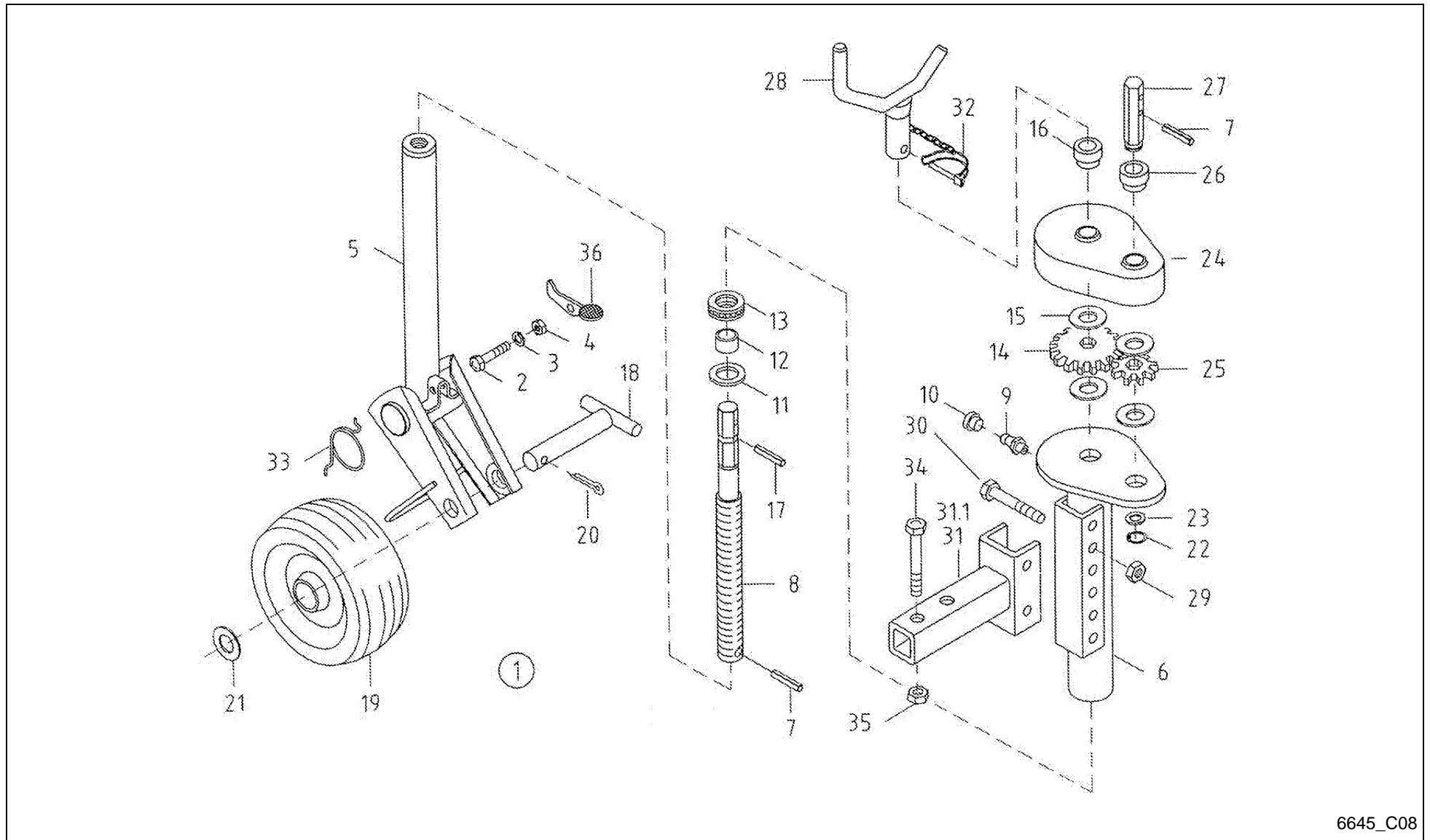

6645_C08



Alpex 280 / SUPPORT WHEEL

PosNo.	Part No.	Qty.	Description	Remark
1	VF16613284	1	SUPPORT ROLLER	
2	VF01111145	1	HEX. HEAD SCREW	
3	VF06214358	1	WASHER	
4	VF01104944	1	NY LOCK NUT 8A3CD985	
5	VF16614481	1	INNER TUBE	
6	VF16614482	1	EXTERNAL TUBE	
7	VF01157325	2	DOWEL PIN	
8	VF16516821	1	SPINDLE	
9	VF01120693	1	GREASE FITTING H1 AM 8X1 DIN 71412	
10	VF16514101	1	PLUG	
11	VF16516836	1	WASHER/DISC/PLATE	
12	VF16614476	1	BUSH	
13	VF16516824	1	THRUST BEARING	
14	VF16516826	1	GEAR	
15	VF16516827	4	RING	
16	VF16516828	1	BUSH	
17	VF01115457	1	DOWEL PIN	
18	VF16614484	1	PIN	
19	VF16614485	1	WHEEL	
20	VF01106474	1	SPLIT PIN	
21	VF06214236	1	WASHER	
22	VF01107727	1	CIRCLIP	
23	VF06214470	1	SPACER	
24	VF16614477	1	HOUSING	
25	VF16516829	1	GEAR	
26	VF16516830	1	BUSH	
27	VF16516831	1	SHAFT	
28	VF16614483	1	CRANK HANDLE	
29	VF06209774	2	LOCK NUT	
30	VF01139339	2	HEX.BOLT	
31	VF16614478	1	RETAINER	
31.1	VF16631486	1	RETAINER	+A 2007
32	VF16611281	1	FOLDING PLUG	
33	VF16518312	1	RETURN SPRING	
34	VF16630548	1	HEXAGON HEAD SCREW M16X130 D931 10.9	
35	VF01127856	1	LOCK NUT	
36	VF16516834	1	LEVER/ARM	

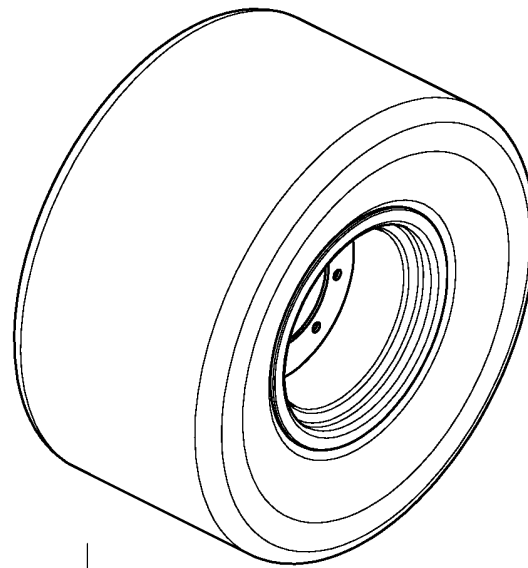

1, 2, 3

6645_C09

Alpex 280 / ASSORTMENT OF WHEEL



PosNo.	Part No.	Qty.	Description	Remark
1	A143014200	2	WHEEL	
2	A143014300	2	WHEEL	Option
3	VF16512621	2	WHEEL	Option

Alpex 280 / BPW TRAILER AXLE

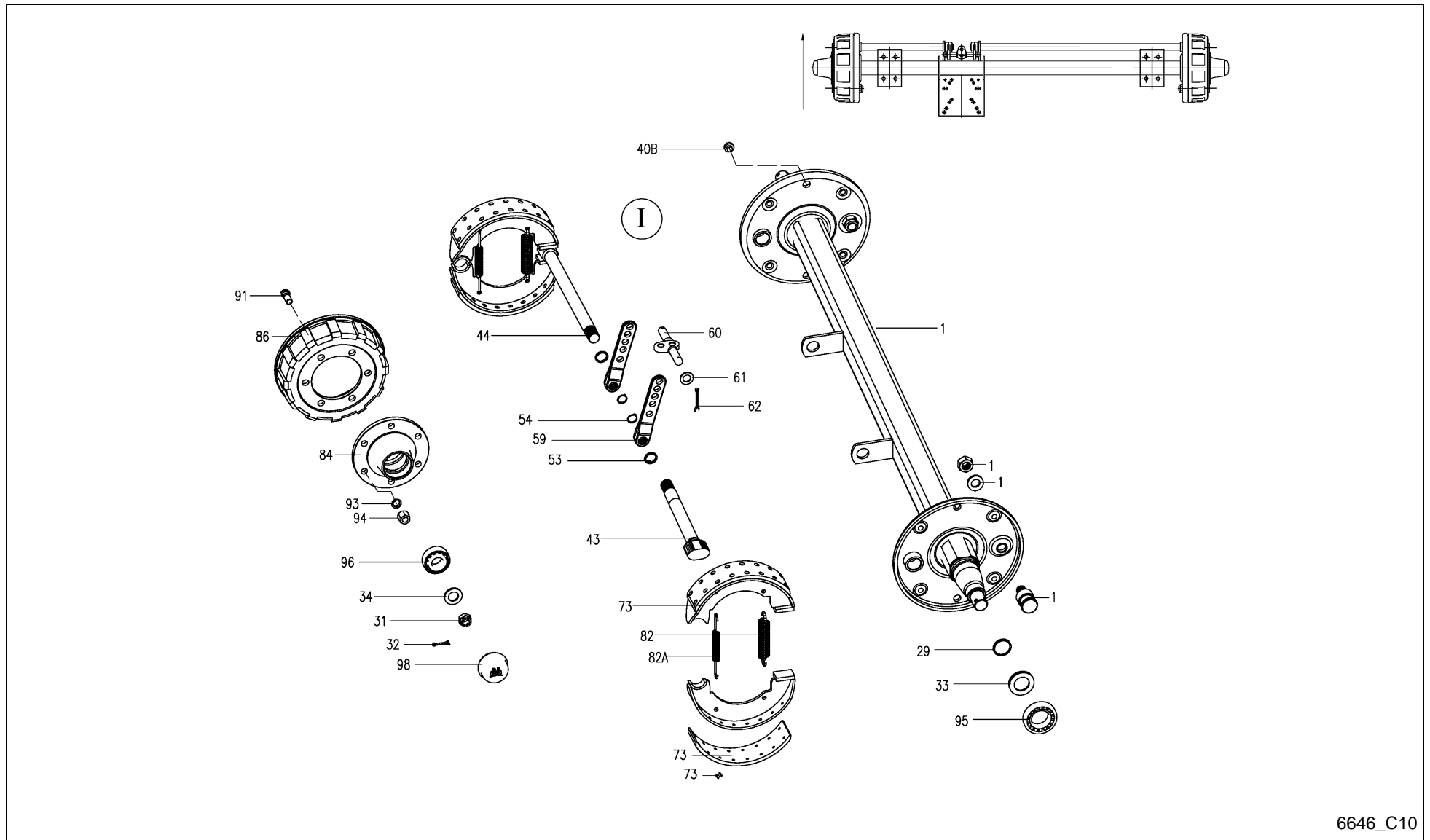

6646_C10



Alpex 280 / BPW TRAILER AXLE

PosNo.	Part No.	Qty.	Description	Remark
I	VF16631786	1	BRAKING AXLE 6 TONS	
1	A143488500	1	AXLE BODY, GROUP	
29	VF16618697	2	RING	
31	VF16612406	2	CASTLE NUT	
32	A143507700	2	SPLIT PIN 5X45 ISO1234	
33	VF16602598	2	SEAL RING	
40B	VF16624942	4	PLUG	
43	A143507800	1	BRAKE CAMSHAFT L=1153 / A=1066	
44	A143507900	1	BRAKE CAMSHAFT L=553 / A=466	
53	A143503300	2	RING 42/34X4	
54	VF16618627	2	CIRCLIP	
59	A143508000	2	BRAKE LEVER 22/100-230	
60	VF03.110.02.140	1	BRAKE BALANCE	
61	A143504600	2	WASHER 21 DIN125	
62	A143505100	2	SPLIT PIN 5X28 ISO1234	
73	VF16618629	4	BRAKE SHOE	
82	VF16624941	2	TENSION SPRING	
82A	VF16617332	2	TENSION SPRING	
84	VF16617329.86	2	WHEEL HUB	
86	A143508100	2	BRAKE DRUM	
91	VF16612402	12	WHEEL STUD	
93	VF16618602	12	SPRING WASHER	
94	VF16618603	12	FLAT-COLLAR NUT	
95	VF16618604	2	FLAT-COLLAR NUT	
96	A143503800	2	TAPER ROLLER BEARING 30207	
98	VF16612405	2	WHEEL CAP	

Alpex 280 / HYDRAULIC FOR BRAKE DEV. SINGLE AXLE (-0180)

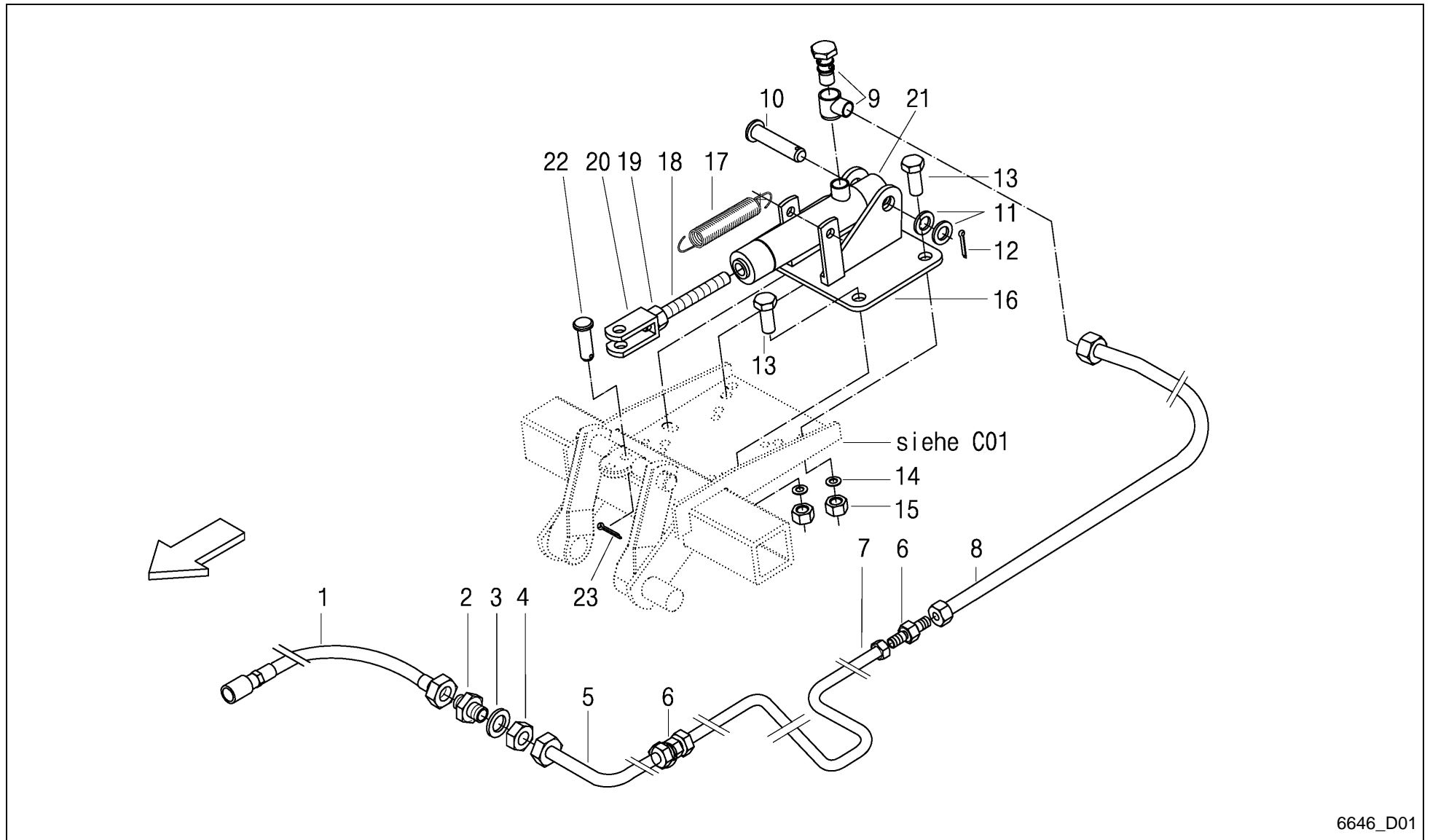

6646_D01

Alpex 280 / HYDRAULIC FOR BRAKE DEV. SINGLE AXLE (-0180)



PosNo.	Part No.	Qty.	Description	Remark
1	VF16613255	1	HYDR.HOSE	
2	VF01100600	1	STRAIGHT CONNECTOR XSV 12-L CF	
3	VF01124633	1	WASHER	
4	VF06216908	1	WHEEL NUT M 18X1,5 DIN80705	
5	VF16631727	1	HYDR. PIPE	
6	VF01116708	2	CONNECTING SLEEVE	
7	VF16631854	1	HYDR. PIPE	
8	VF16631729	1	HYDR. PIPE	
9	VF16631726	1	UNION 2-PIECE	
10	A143484600	1	BOLT B16 ISO2341	
11	A143476900	2	WASHER 16 ISO8738	
12	A143472600	1	SPLIT PIN 4X25 ISO1234	
13	A143493400	4	HEXAGON HEAD SCREW M14X35 DIN933	
14	A143493500	4	SPRING WASHER A14 DIN128	
15	A143493600	4	NUT M14 DIN934	
16	A143493700	1	RETAINER	
17	VF05.397.26.03	2	TENSION SPRING	
18	VF03.178.50.41	1	THREADED PIN D14 L125	
19	A143493800	1	NUT M16X1,5 DIN936	
20	A143476100	1	CLEVIS,	
21	VF05.444.50.12	1	CYLINDER D=25	
22	VF01397843	1	PIN/BOLT/STUD	
23	VF01106451	1	SPLIT PIN	

Alpex 280 / HYDRAULIC FOR BRAKE DEV. SINGLE AXLE (+0181)

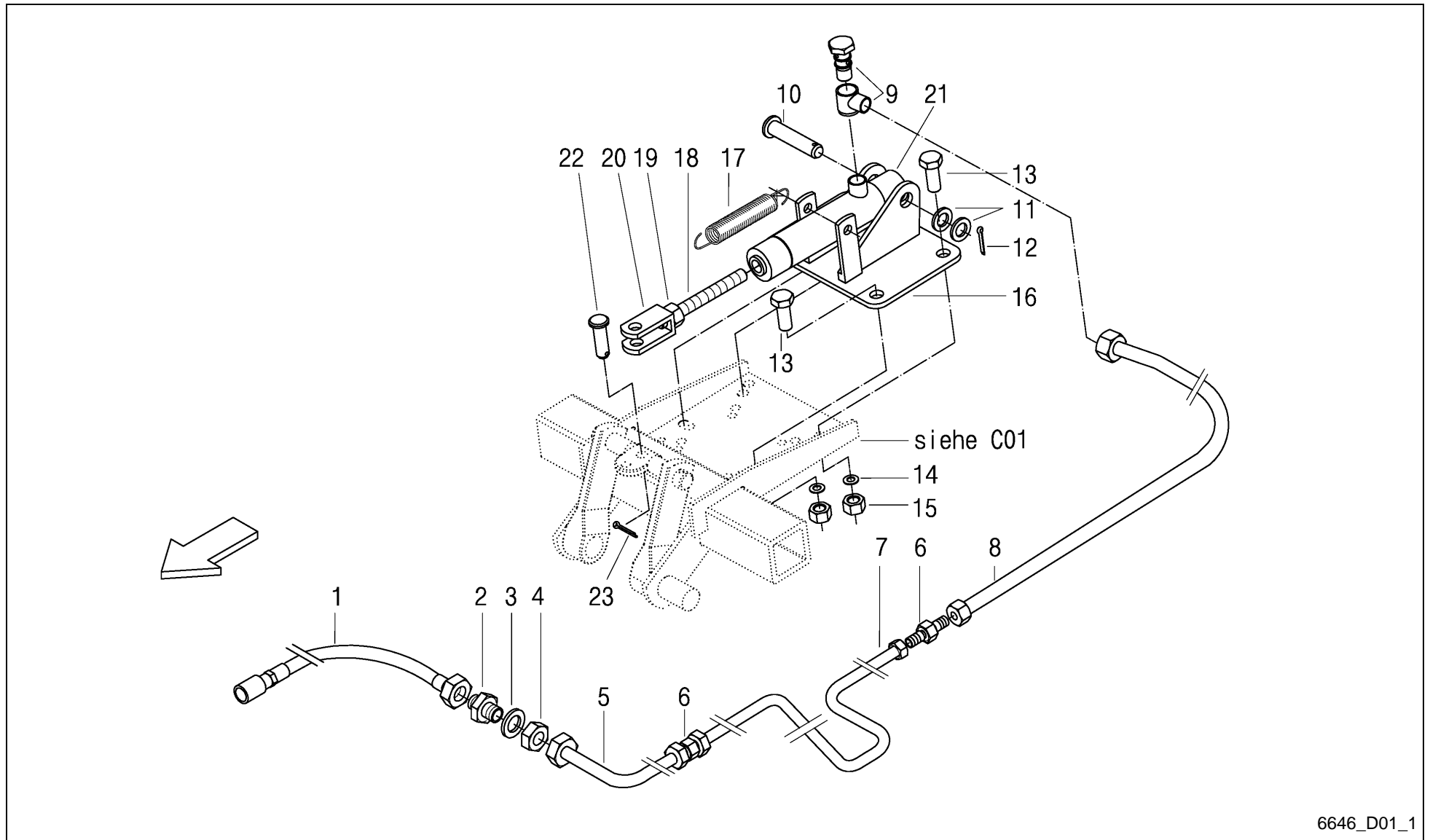

6646_D01_1

Alpex 280 / HYDRAULIC FOR BRAKE DEV. SINGLE AXLE (+0181)



PosNo.	Part No.	Qty.	Description	Remark
1	VF16613255	1	HYDR.HOSE	
2	VF01100600	1	STRAIGHT CONNECTOR XSV 12-L CF	
3	VF01124633	1	WASHER	
4	VF06216908	1	WHEEL NUT M 18X1,5 DIN80705	
5	VF16631727	1	HYDR. PIPE	
6	VF01116708	2	CONNECTING SLEEVE	
7	VF16631854	1	HYDR. PIPE	
8	VF16631729	1	HYDR. PIPE	
9	VF16631726	1	UNION 2-PIECE	
10	A143484600	1	BOLT B16 ISO2341	
11	A143476900	2	WASHER 16 ISO8738	
12	A143472600	1	SPLIT PIN 4X25 ISO1234	
13	A143493400	4	HEXAGON HEAD SCREW M14X35 DIN933	
14	A143493500	4	SPRING WASHER A14 DIN128	
15	A143493600	4	NUT M14 DIN934	
16	A143493700	1	RETAINER	
17	VF05.397.26.03	2	TENSION SPRING	
18	VF03.178.50.41	1	THREADED PIN D14 L125	
19	A143493800	1	NUT M16X1,5 DIN936	
20	A143476100	1	CLEVIS,	
21	VF05.444.50.12	1	CYLINDER D=25	
22	VF01397843	1	PIN/BOLT/STUD	
23	VF01106451	1	SPLIT PIN	

Alpex 280 / HYDR. FOR CRANKED DRAWBAR (-0180)

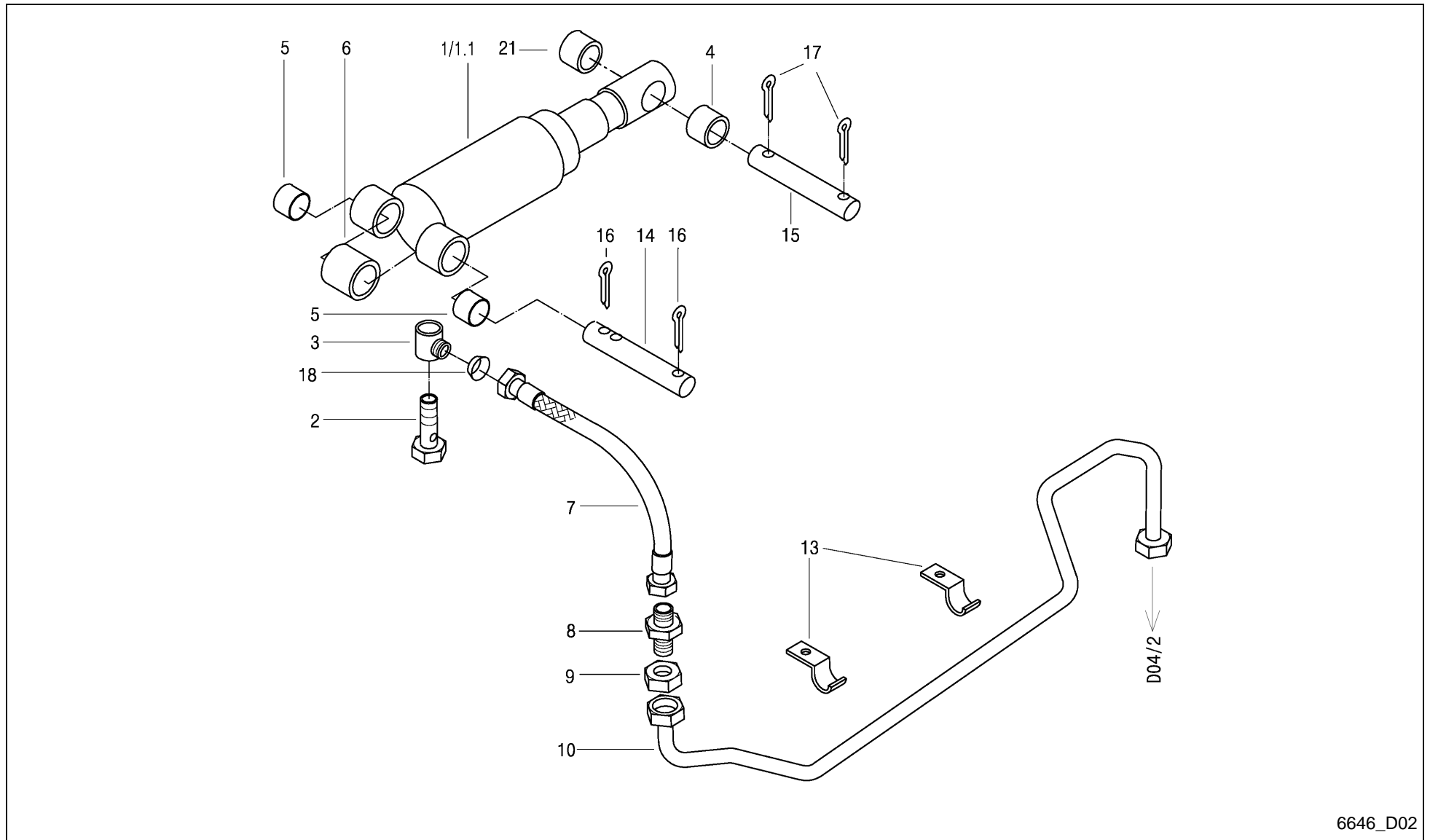

6646_D02

Alpex 280 / HYDR. FOR CRANKED DRAWBAR (-0180)



PosNo.	Part No.	Qty.	Description	Remark
1	VF16630158	1	HYDRAULIC CYLINDER	
1.1	VF16630159	1	SEALING SET	X 1
2	VF01141296	1	HOLLOW BOLT	
3	VF01141295	1	UNION	
4	VF16631223	1	BUSH	
5	VF16631225	2	BUSH	
6	VF16631224	1	BUSH	
7	VF01142641	1	HYDR. HOSE 0BODN6X 800 DKOL-8L+DKOL-8L	
8	VF01123941	1	STRAIGHT CONNECTOR XSV 8-L CF	
9	VF01121824	1	NUT M14X1,5 GM08L CF	
10	VF16631889	1	HYDR. PIPE	
13	VF06216397	2	FIXING CLIP	
14	VF06554569	1	PIN	S F05
15	VF16631685	1	BOLT D=25MM	S F05
16	VF01143009	2	SPLIT PIN	
17	VF01132647	2	SPLIT PIN	
18	VF06581181	1	RESTRICTOR 1,0 MM D8,0X1	
21	VF06554571	1	TUBE	

Alpex 280 / HYDR. FOR CRANKED DRAWBAR (+0181)

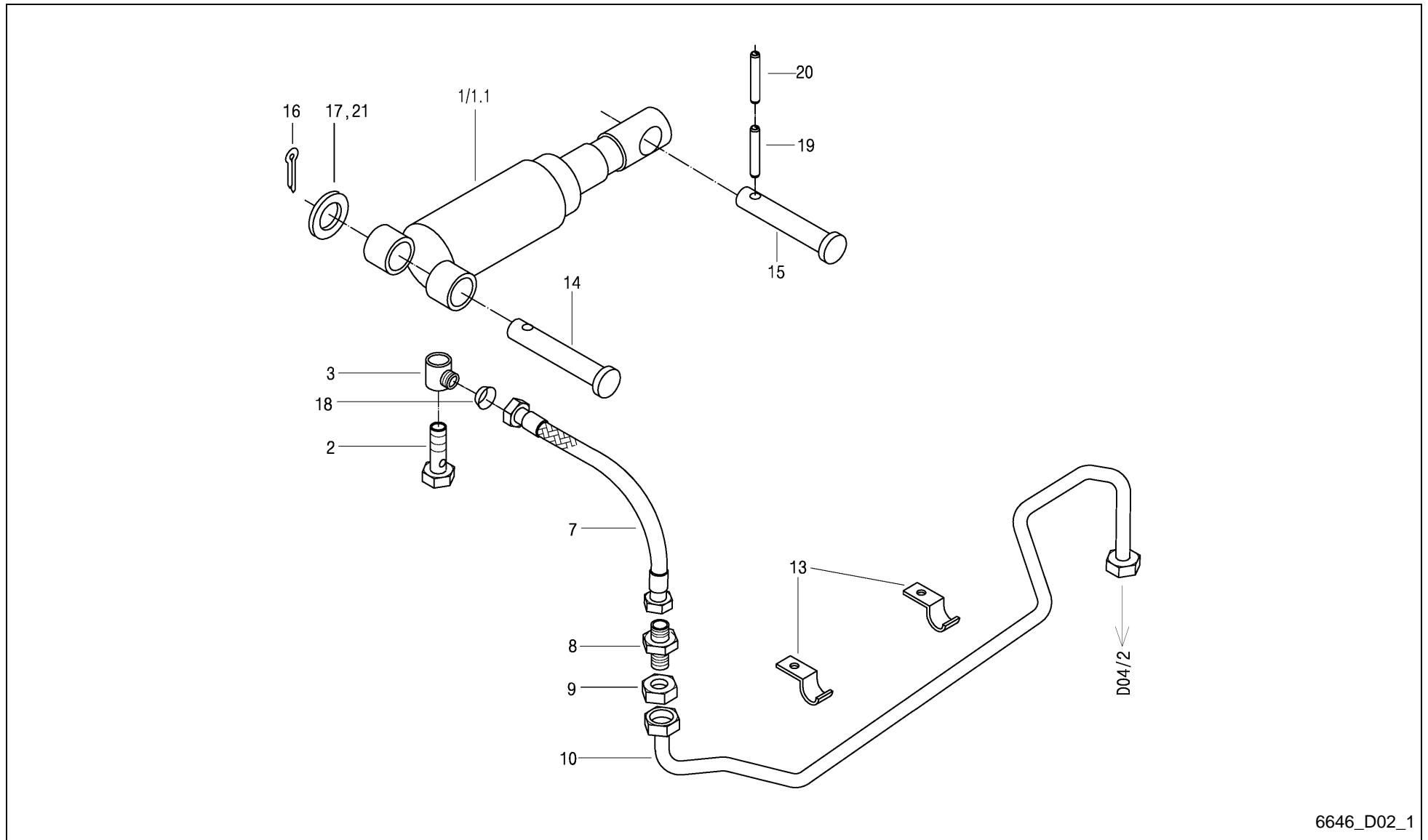

6646_D02_1



Alpex 280 / HYDR. FOR CRANKED DRAWBAR (+0181)

PosNo.	Part No.	Qty.	Description	Remark
1	VF16630158	1	HYDRAULIC CYLINDER	
1.1	VF16630159	1	SEALING SET	X 1
2	VF01141296	1	HOLLOW BOLT	
3	VF01141295	1	UNION	
7	VF01142641	1	HYDR. HOSE 0BODN6X 800 DKOL-8L+DKOL-8L	
8	VF01123941	1	STRAIGHT CONNECTOR XSV 8-L CF	
9	VF01121824	1	NUT M14X1,5 GM08L CF	
10	VF16631889	1	HYDR. PIPE	
13	VF06216397	2	FIXING CLIP	
14	VF01397555	1	PIN/BOLT/STUD	S F05
15	VF16635313	1	BOLT D=33MM	S F05
16	VF01106500	1	SPLIT PIN 8X50DIN94 GALV.	
17	VF06214237	1	WASHER	
18	VF06581181	1	RESTRICTOR 1,0 MM D8,0X1	
19	VF01157345	1	DOWEL PIN	
20	VF01136930	1	DOWEL PIN	
21	VF06214238	1	WASHER 34X50X5 A2C DIN 1441	

Alpex 280 / HYDRAULIS AND DRIVE F. SCRAPER FLOOR

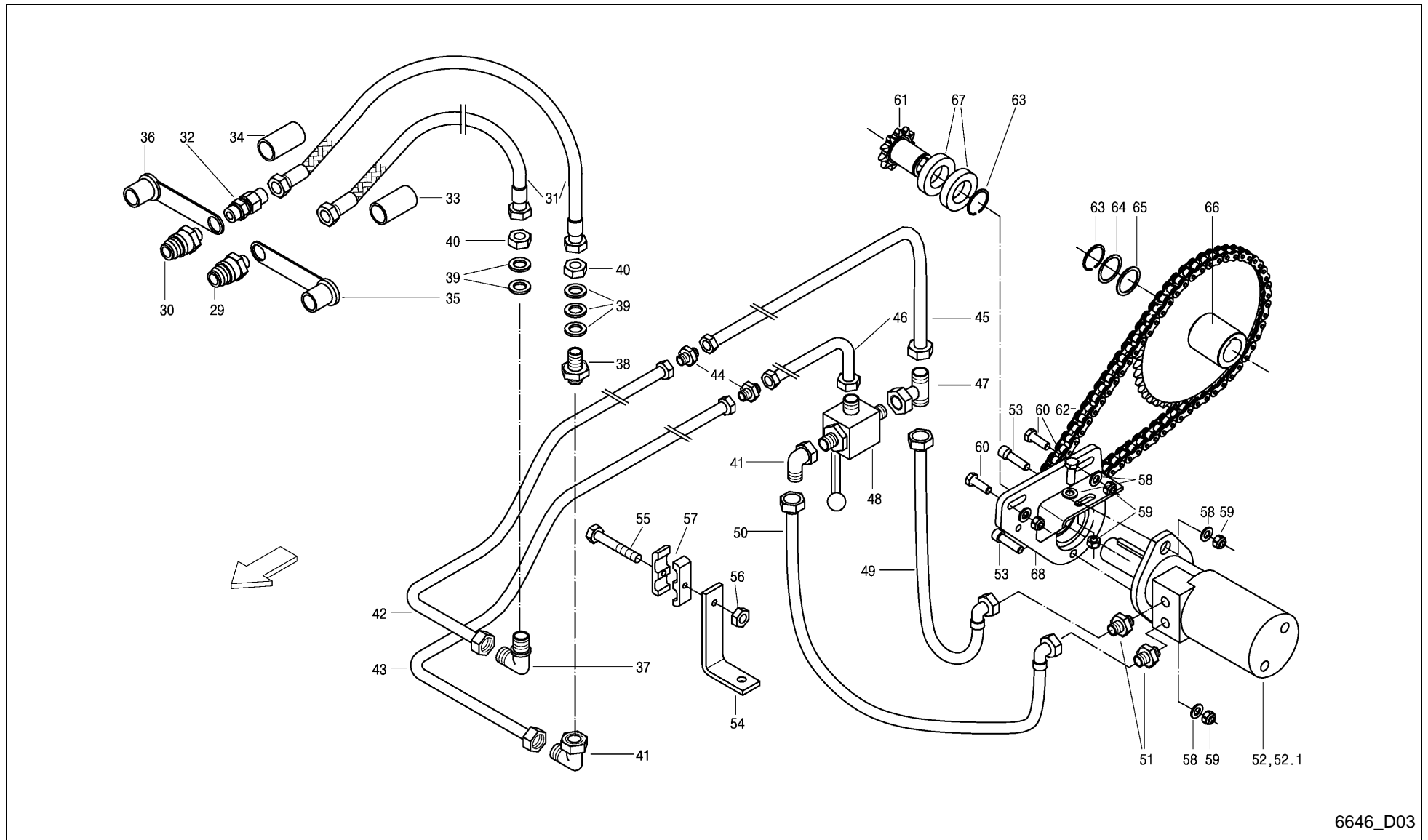

6646_D03



Alpex 280 / HYDRAULIS AND DRIVE F. SCRAPER FLOOR

PosNo.	Part No.	Qty.	Description	Remark
29	VF06571330	1	HOSE CONNECTION NW10, IG M 22X1,5	
30	VF16613435	1	SAFETY PIN	
31	VF16610873	2	HYDR.HOSE	
32	VF01397770	1	CHECK VALVE	
33	VF16515428	1	SHRINK TUBE RED 25X50	
34	VF16513948	1	SHRINK TUBE YELLOW 25X50	
35	VF01142006	1	DUST CAP	
36	VF06571341	1	DUST CAP BLACK 27MM DIAMETER	
37	VF01116758	1	TWO-WAY CONNECTOR	
38	VF01133922	1	NOZZLE AL15 D3910 GALV.	
39	VF06214306	5	WASHER 23X38X2 GALV. HV200	
40	VF01137633	2	WHEEL NUT M22 X 1,5 DIN80705 A2C	
41	VF16613433	2	ANGLE UNION	
42	VF16631692	1	HYDR. PIPE	
43	A143018800	1	HYDRAULIC PIPE	
44	VF01116710	2	CONNECTING SLEEVE	
45	VF16631849	1	HYDR. PIPE	
46	VF16631851	1	HYDR. PIPE	
47	VF16613434	1	T-CONNECTOR XET 15-L GALV.	
48	VF16613436	1	ROOSTER	
49	VF16613446	1	HYDR.HOSE	
50	VF16613447	1	HYDR.HOSE	
51	VF06216836	2	SOCKET XGE 15LR-ED CF	
52	VF16631611	1	HYDR. MOTOR EPM 250	
52.1	VF16630900		SEALING KIT HYDR. ENGINE	für Hydraulikmotor EPM
53	VF06214156	2	SCREW	
54	VF16613380	2	BRACKET	
55	VF01122389	6	HEX.HEAD SCREW	
56	VF01114357	6	LOCK NUT	
57	VF06578035	12	CLAMP	
58	VF06214207	5	WASHER	
59	VF06209769	5	LOCK NUT	
60	VF01112538	3	HEX.HEAD SCREW	
61	VF16631621	1	PINION 11Z	
62	VF16631624	1	ROLLER CHAIN 12B-1V70E INCL.VGL	
63	VF01107755	2	CIRCLIP	
64	VF06214332	1	WASHER	
65	VF06214333	1	WASHER	
66	VF16631614	1	SPROCKET	
67	VF16631612	2	GROOVED BALL BEARING 6008RS	

Alpex 280 / HYDRAULIS AND DRIVE F. SCRAPER FLOOR

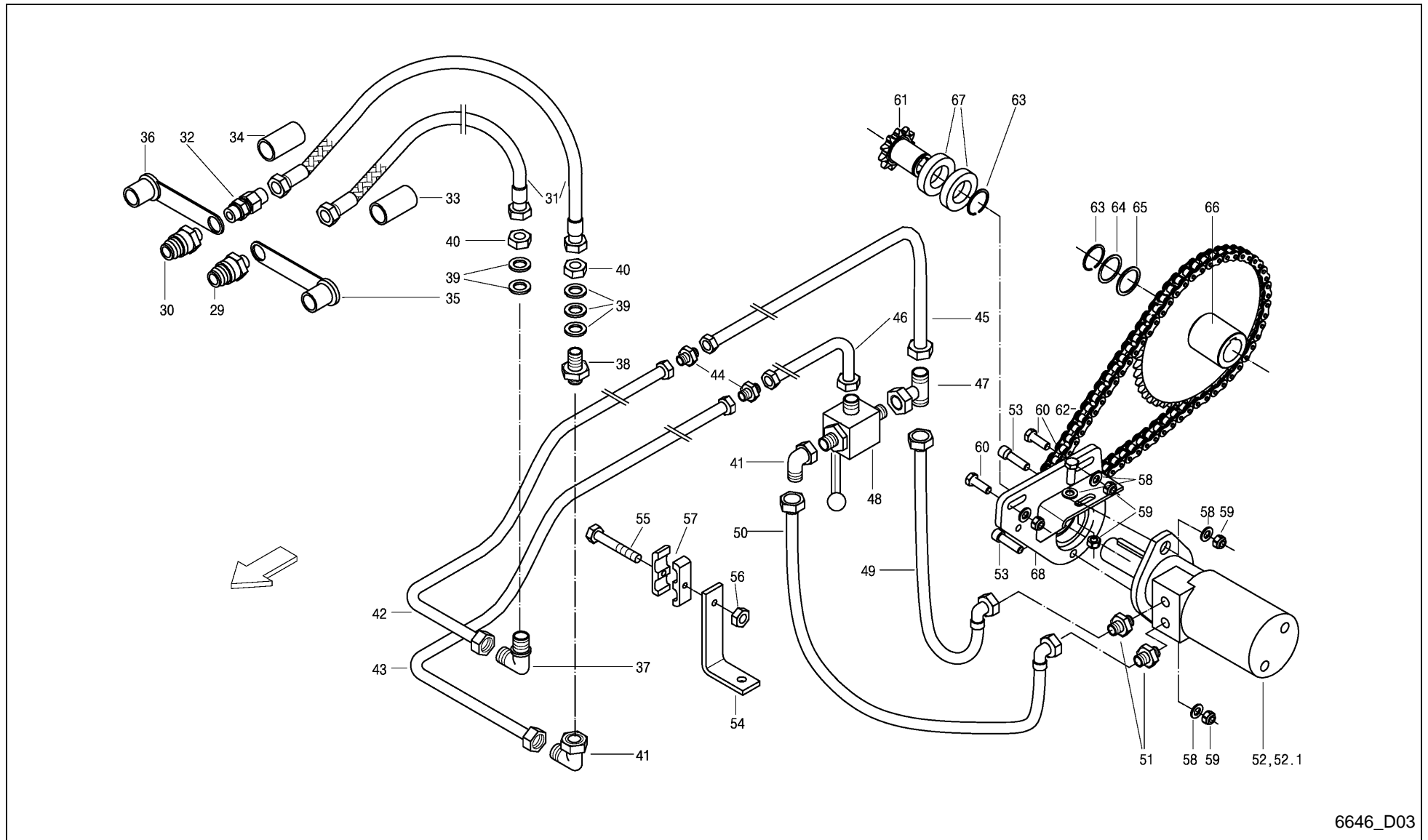

6646_D03

Alpex 280 / HYDRAULIS AND DRIVE F. SCRAPER FLOOR



PosNo.	Part No.	Qty.	Description	Remark
68	VF16631617	1	BASE PLATE	

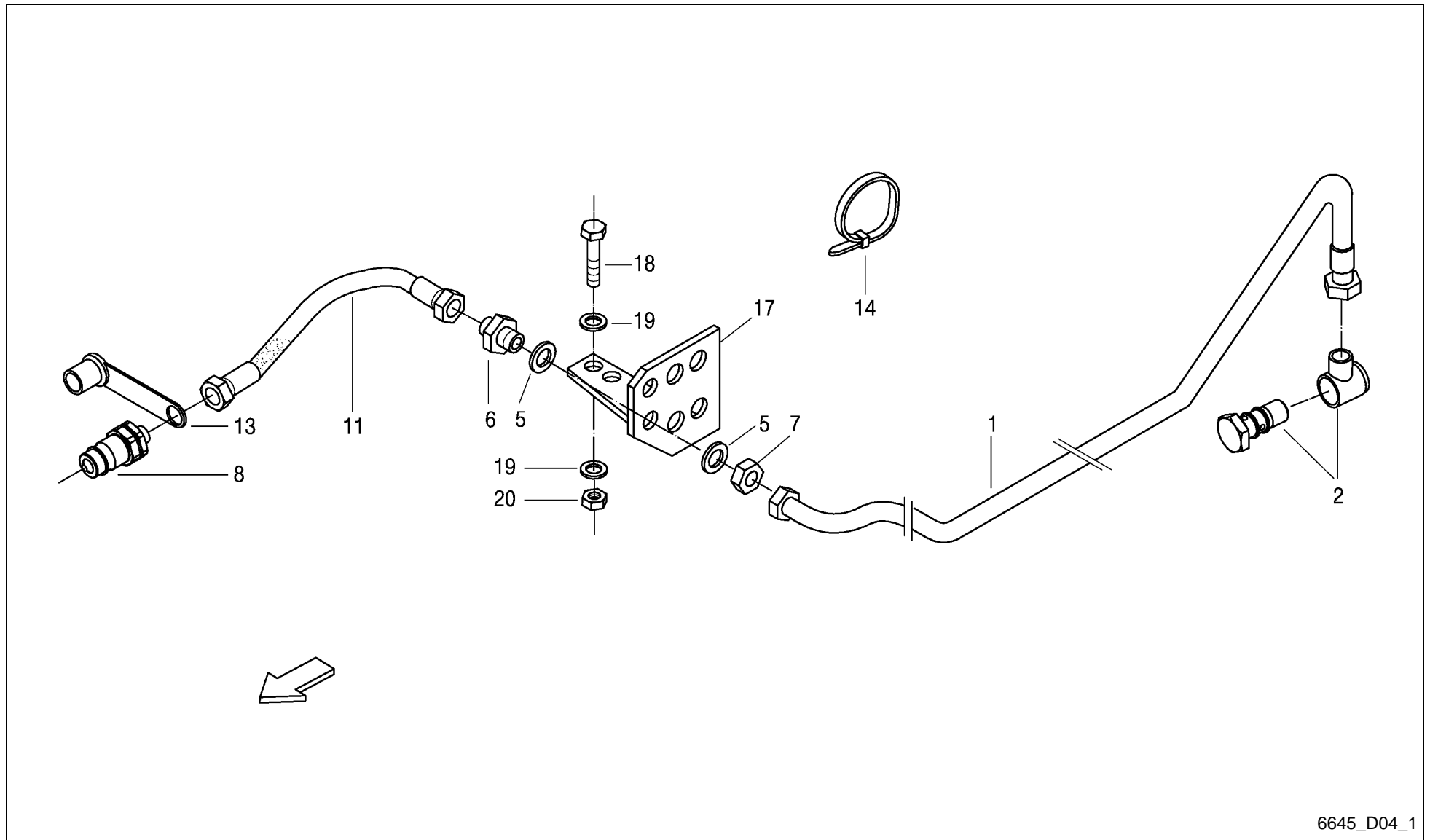

6645_D04_1

Alpex 280 / HYDR. INSTALATION BASIC CONTENT



PosNo.	Part No.	Qty.	Description	Remark
1	VF16613449	1	HYDR.PIPE	
2	VF16631123	1	UNION 2 PIECE	
5	VF06214202	2	WASHER 14X24X1,6 GALV.	
6	VF01123941	1	STRAIGHT CONNECTOR XSV 8-L CF	
7	VF01121824	1	NUT M14X1,5 GM08L CF	
8	VF16615171	1	PLUG CONTACT DN 10 EXTE. THREAD M 14X1,5	
11	VF06582530	1	HYDR. HOSE 0BODN6X2500 DKOL-8L+DKOL-8L	
13	VF06571341	1	DUST CAP BLACK 27MM DIAMETER	
14	VF06216479	1	CABLE TIE 150X3,6 SW SNX 2-35	
17	VF16518890	1	PLATE	
18	VF01112418	2	BOLT, SCREW	
19	VF01107103	4	WASHER/DISC/PLATE	
20	VF06209768	2	LOCK NUT	

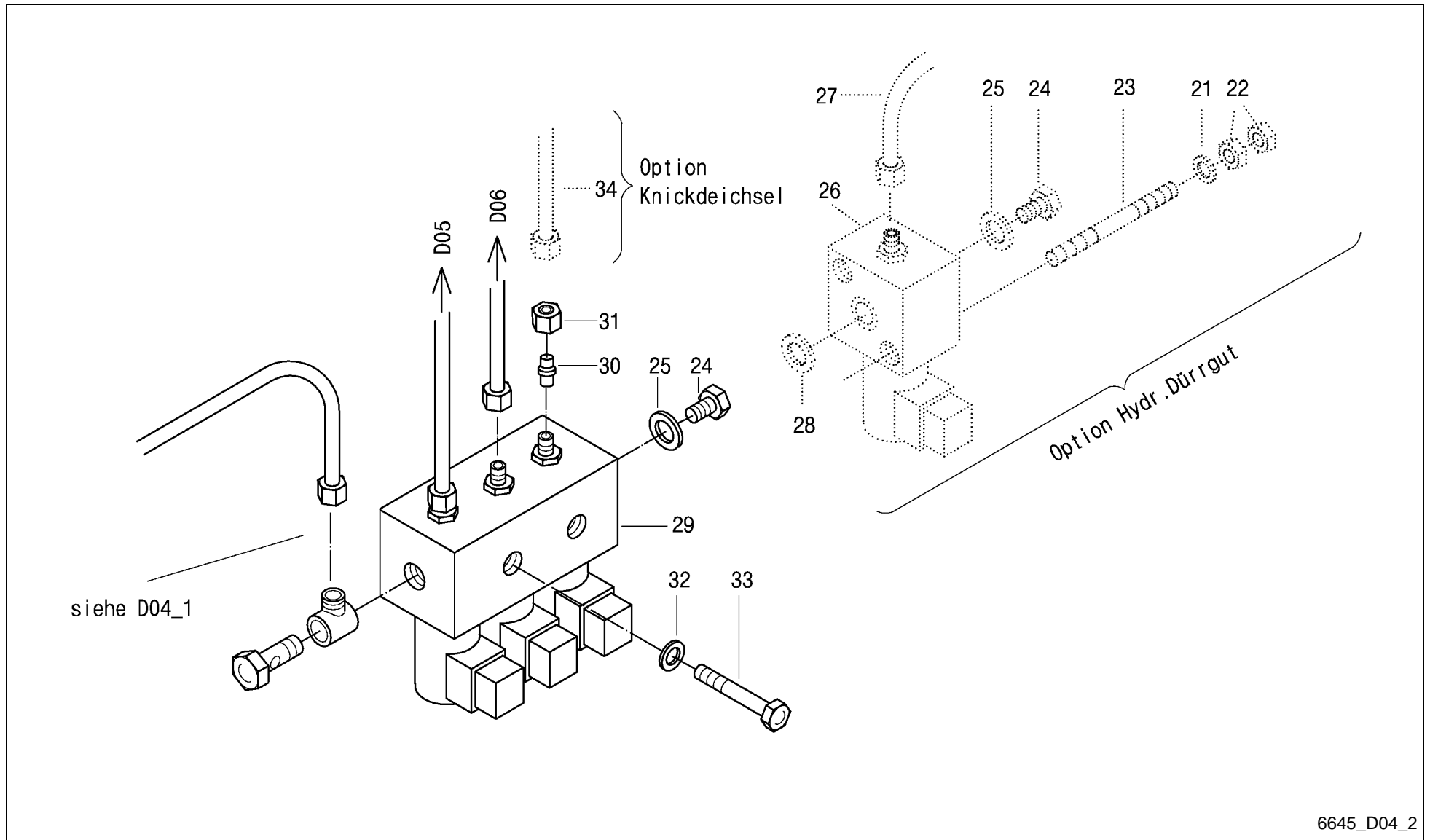

6645_D04_2



Alpex 280 / HYDR. INSTALATION BASIC CONTENT + OPTIONS

PosNo.	Part No.	Qty.	Description	Remark
21	VF01143103	1	WASHER/DISC/PLATE	Option Hydr. Dürrgut
22	VF01112824	2	HEX. NUT	Option Hydr. Dürrgut
23	VF16630486	2	THREADED PIN BM8X90 8.8 DIN978	Option Hydr. Dürrgut
24	VF01143104	1	SCREW PLUG	Option Hydr. Dürrgut
25	VF01118675	1	SEAL RING	Option Hydr. Dürrgut
26	VF16631291	1	VALVE BLOCK WITH MANUAL EMERGENCY	Option Hydr. Dürrgut
27	VF16631883	1	HYDR. PIPE	Option Hydr. Dürrgut
28	VF01169581	1	O-RING	Option Hydr. Dürrgut
29	VF16516558	1	VALVE BLOCK	
30	VF01141575	1	PLUG BUZ-8L	
31	VF01127346	1	UNION NUT H3105-CL 8-ST A3C	
32	VF01107163	1	WASHER	
33	VF01111168	1	HEX. HEAD SCREW	
34	VF16631889	1	HYDR. PIPE	Option Knickdeichsel

Alpex 280 / HYDRAULIC FOR PICK-UP

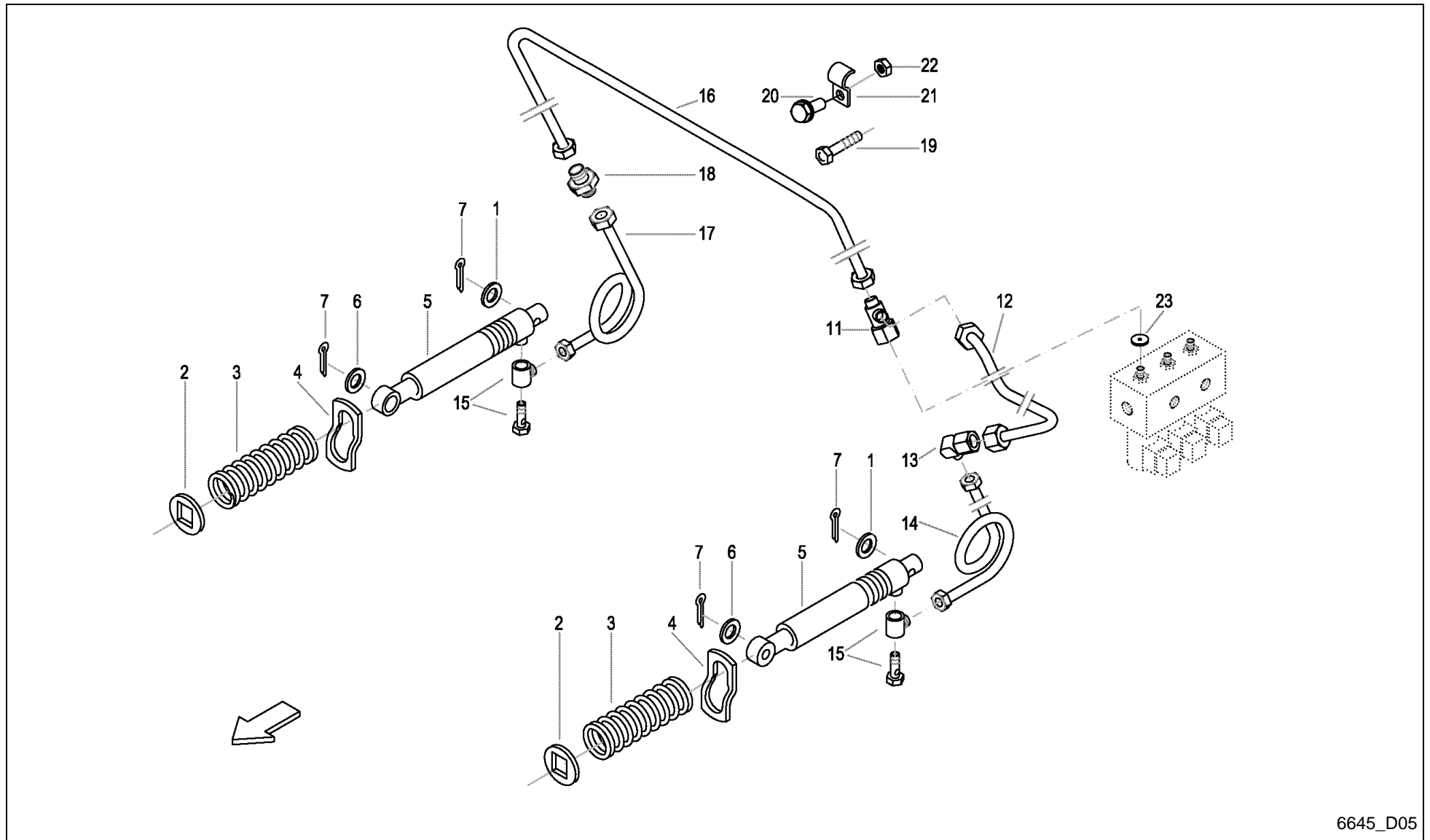

6645_D05

Alpex 280 / HYDRAULIC FOR PICK-UP



PosNo.	Part No.	Qty.	Description	Remark
1	KG01273861	2	WASHER DIN7349 M14 A3C	
2	VF16519184	2	WASHER/DISC/PLATE	
3	VF06215425	2	COMPRESSION SPRING	
4	VF06576503	2	CLIP	
5	VF16514631	2	CYLINDER	
5	VF16504079		SEALING SET	
6	VF06214585	2	WASHER	
7	VF01106451	4	SPLIT PIN	
11	VF01141654	1	NOZZLE XEVL 8-L GALV.	
12	VF16631698	1	HYDR. PIPE	
13	VF01116731	1	SOCKET D3905 L 8 W08LCFX	
14	VF06577864	1	HYDR.PIPE	
15	VF16631123	2	UNION 2 PIECE	
16	VF16631699	1	HYDR. PIPE	
17	VF16613306	1	HYDR.HOSE	
18	VF01116705	1	CONNECTING SLEEVE XG 8-L CF	
19	VF01112264	1	HEX. HEAD SCREW	
20	VF16631049	3	DRILLING SCREW 6.3X19 D7504	
21	VF06216397	4	FIXING CLIP	
22	VF01114357	1	LOCK NUT	
23	VF06581181	1	RESTRICTOR 1,0 MM D8,0X1	
24	VF01107095	1	WASHER 6,4DIN125 GALV.	

Alpex 280 / HYDRAULIC FOR REAR GATE

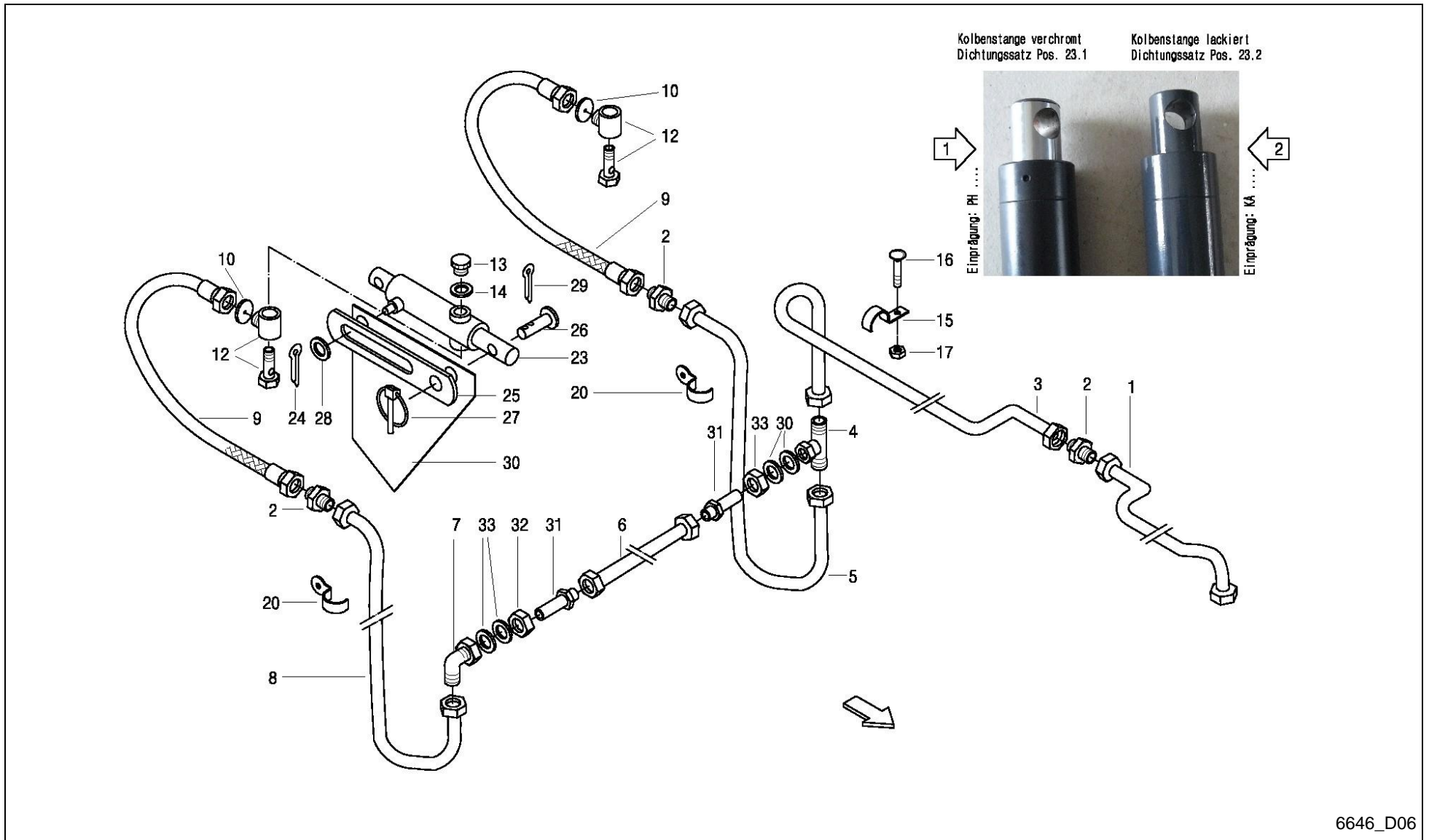



Alpex 280 / HYDRAULIC FOR REAR GATE

PosNo.	Part No.	Qty.	Description	Remark
1	VF16631705	1	HYDR. PIPE	
2	VF01116705	3	CONNECTING SLEEVE XG 8-L CF	
3	VF16631833	1	HYDR. PIPE	
4	VF16631609	1	NOZZLE 14/2-290/L8V ZN	
5	VF16631707	1	HYDR. PIPE	
6	VF16631708	1	HYDR. PIPE	
7	VF01172986	1	ELBOW UNION XEVW 8-L CF	
8	VF16631709	1	HYDR. PIPE	
9	VF16613311	2	HYDR.HOSE	
10	VF06581181	2	RESTRICTOR 1,0 MM D8,0X1	
12	VF16631123	2	UNION 2 PIECE	
13	VF01143104	2	SCREW PLUG	
14	VF16611312	2	SEALING RING	
15	VF06216397	5	FIXING CLIP	
16	VF01142077	5	SAUCER HEAD SCREW	
17	VF01114357	5	LOCK NUT	
20	VF06216396	4	HOSE CLIP	
23	VF16630658	2	HYDR. CYLINDER 30X300	
23.1	VF16630657		SEALING SET	
23.2	A143501400		SEAL KIT	
24	VF01122072	2	SPLIT PIN	
25	VF16515976	2	LIFT LIMIT	
26	VF16515987	2	PIN/BOLT/STUD	
27	VF16611321	2	LYNCH PIN 4X27 DIN11023 GALV.	
28	VF01107121	2	WASHER	
29	VF01106451	2	SPLIT PIN	
30	VF16611382	2	GUARD PLATE	
31	VF01123941	2	STRAIGHT CONNECTOR XSV 8-L CF	
32	VF01121824	2	NUT M14X1,5 GM08L CF	
33	VF06214202	4	WASHER 14X24X1,6 GALV.	

Alpex 280 / COMPRESSED AIR SYSTEM SINGLE AXLE (ONLY GERMANY)

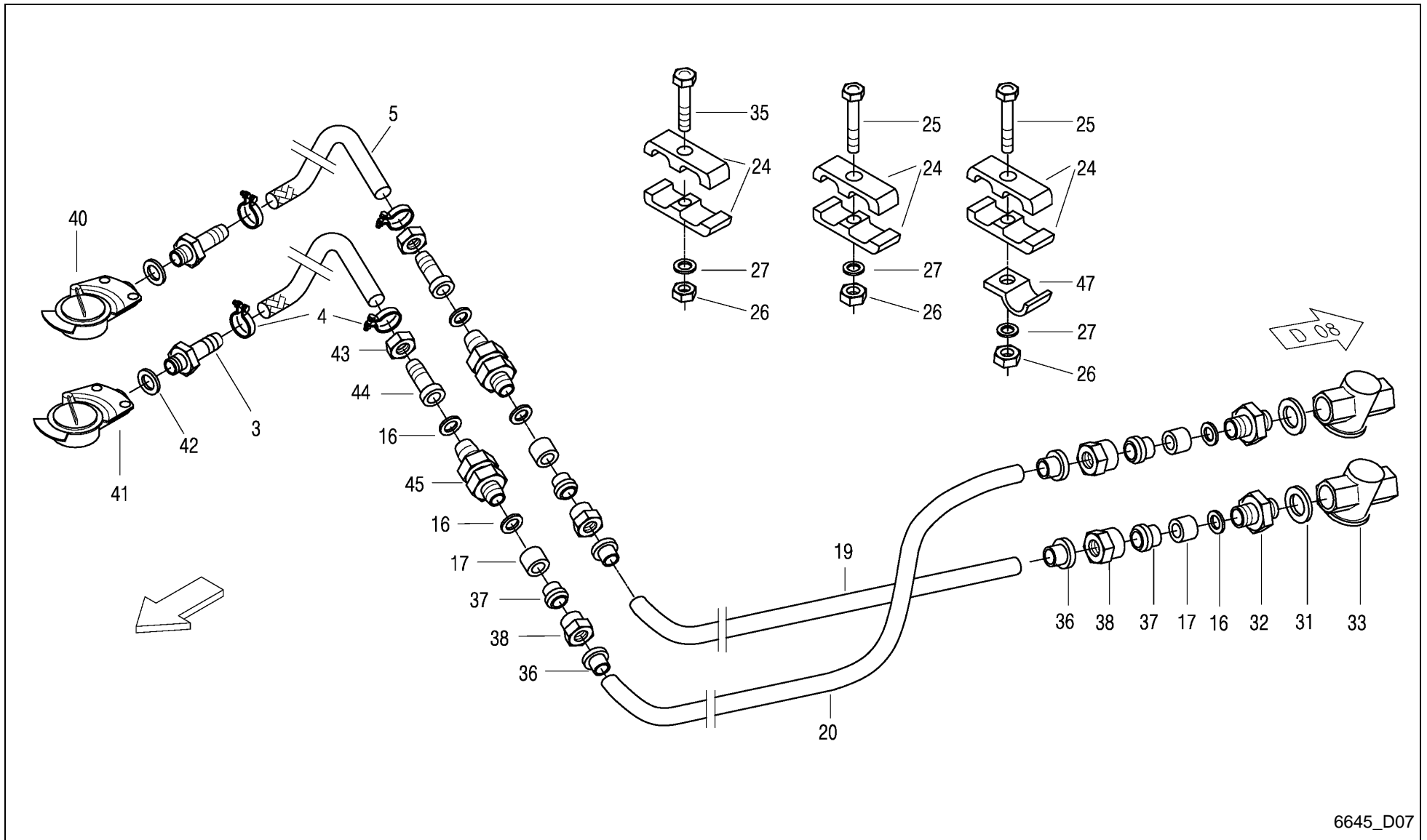

6645_D07

Alpex 280 / COMPRESSED AIR SYSTEM SINGLE AXLE (ONLY GERMANY)



PosNo.	Part No.	Qty.	Description	Remark
3	VF06216771	2	TUBE	
4	VF06216772	4	HOSE CLAMP WEDTH 15	
5	A143046200	2	BRAKE HOSE 2800 MM	
16	VF06277296	6	SEAL RING A12X19X1,5 VF	
17	VF01125146	4	THRUST RING DIN3867-AL15	
19	VF16631908	1	PLASTIC TUBE L=1730	
20	VF16631909	1	PLASTIC TUBE L=1830	
24	VF06578035	6	CLAMP	
25	VF01122389	1	HEX.HEAD SCREW	
26	VF01114357	2	LOCK NUT	
27	VF06214189	2	WASHER 6,4X18X2 A2C	
32	VF01142247	2	NOZZLE XGEB16M22D13	
33	VF06558801	2	FILTER M22X1,5	
35	VF01102664	1	HEX HEAD SCREW	
36	VF02953369	4	PLUG-IN SLEEVE	
37	VF01116626	4	CUTTING RING D15L DIN 3861 ST A3C	
38	VF01125152	4	UNION NUT L15 DIN3872	
40	VF16630646	1	COUPLING HEAD, YELLOW	
41	VF16630647	1	COUPLING HEAD, RED	
42	VF06216757	1	SEAL RING DRM22	
43	VF01142083	2	UNION NUT BLL15DIN3870	
44	VF01121766	2	TUBE DIN74304-A	
45	VF06216763	2	TWIN NOZZEL XGS15M22D99+SM	
46	VF06214307	4	WASHER	
47	VF06216396	1	HOSE CLIP	

Alpex 280 / HYDRAULIC OPERATION DRY FORAGE

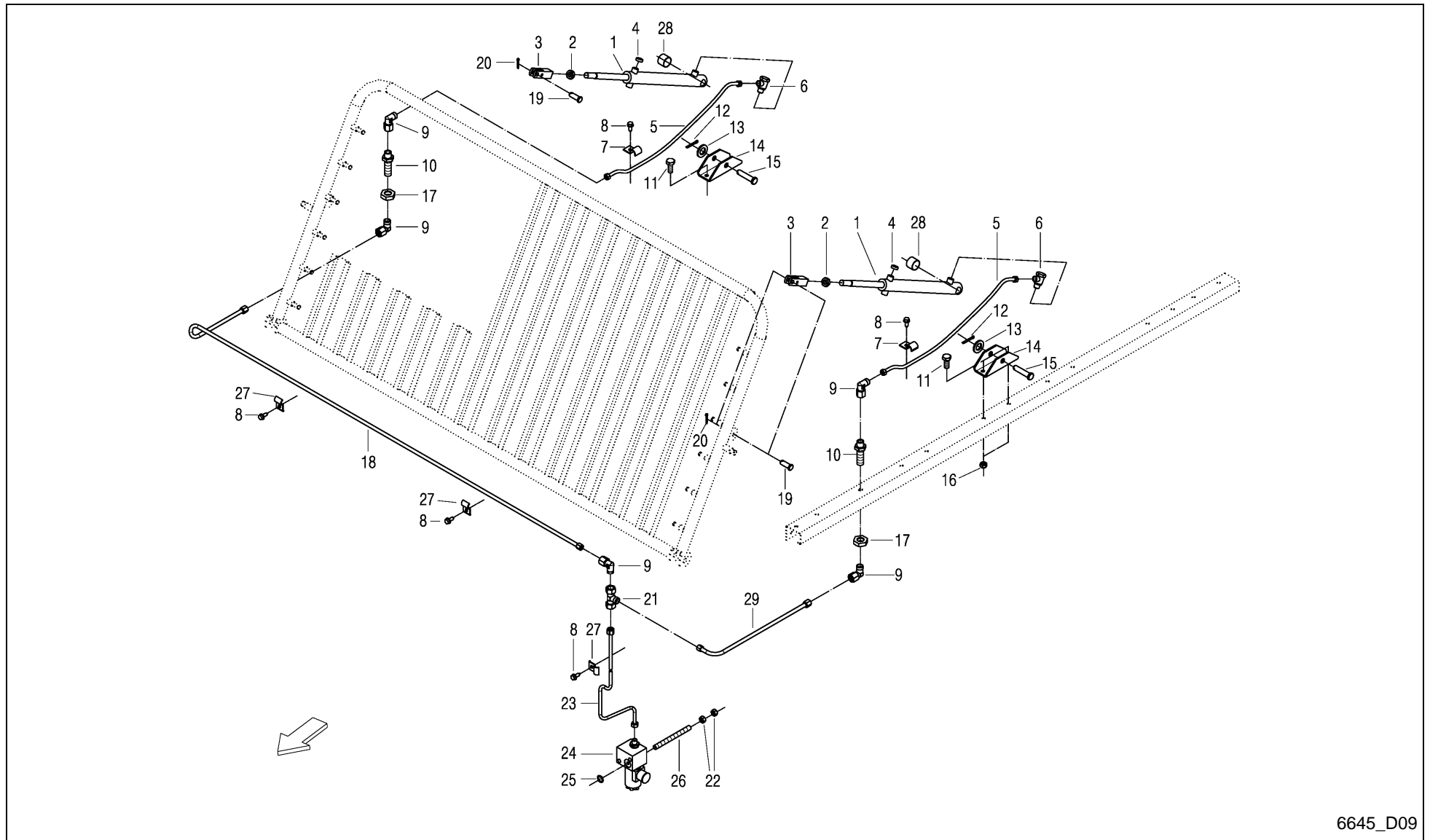

6645_D09

Alpex 280 / HYDRAULIC OPERATION DRY FORAGE



PosNo.	Part No.	Qty.	Description	Remark
1	VF06577987	2	LIFT CYLINDER	
2	VF01131116	2	HEX.NUT	
3	VF06578611	2	CLEVIS	
4	VF01143104	2	SCREW PLUG	
5	VF06562350	2	HYDR. HOSE	
6	VF16631123	2	UNION 2 PIECE	
7	VF06216401	2	FIXING CLAMP	
8	VF16631049	5	DRILLING SCREW 6.3X19 D7504	
9	VF01172986	5	ELBOW UNION XEVW 8-L CF	
29	A143039600	1	HYDRAULIC PIPE	
10	VF01123941	2	STRAIGHT CONNECTOR XSV 8-L CF	
11	VF01112418	4	BOLT, SCREW	
12	VF01106451	2	SPLIT PIN	
13	VF06214295	2	WASHER 17,0X34,0X3,0 DIN 134	
14	VF16631636	2	RETAINER	
15	VF01139468	2	PIN	
16	VF06209768	2	LOCK NUT	
17	VF01121824	2	NUT M14X1,5 GM08L CF	
18	VF16631885	1	HYDR. PIPE	
19	VF06210014	2	PIN	
20	VF01106447	2	SPLIT PIN	
21	VF01116740	1	NOZZLE XT 8-L GALV.	
22	VF01112824	4	HEX. NUT	
23	VF16631883	1	HYDR. PIPE	
24	VF16631291	1	VALVE BLOCK WITH MANUAL EMERGENCY	
25	VF01169581	1	O-RING	
26	VF16630486	1	THREADED PIN BM8X90 8.8 DIN978	
27	VF06216397	3	FIXING CLIP	
28	A143046463	2	SLEEVE Ø23X52	
29	A143039600	1	HYDRAULIC PIPE	

Alpex 280 / LUBE SYSTEM DRUM WITH 3 RAKES

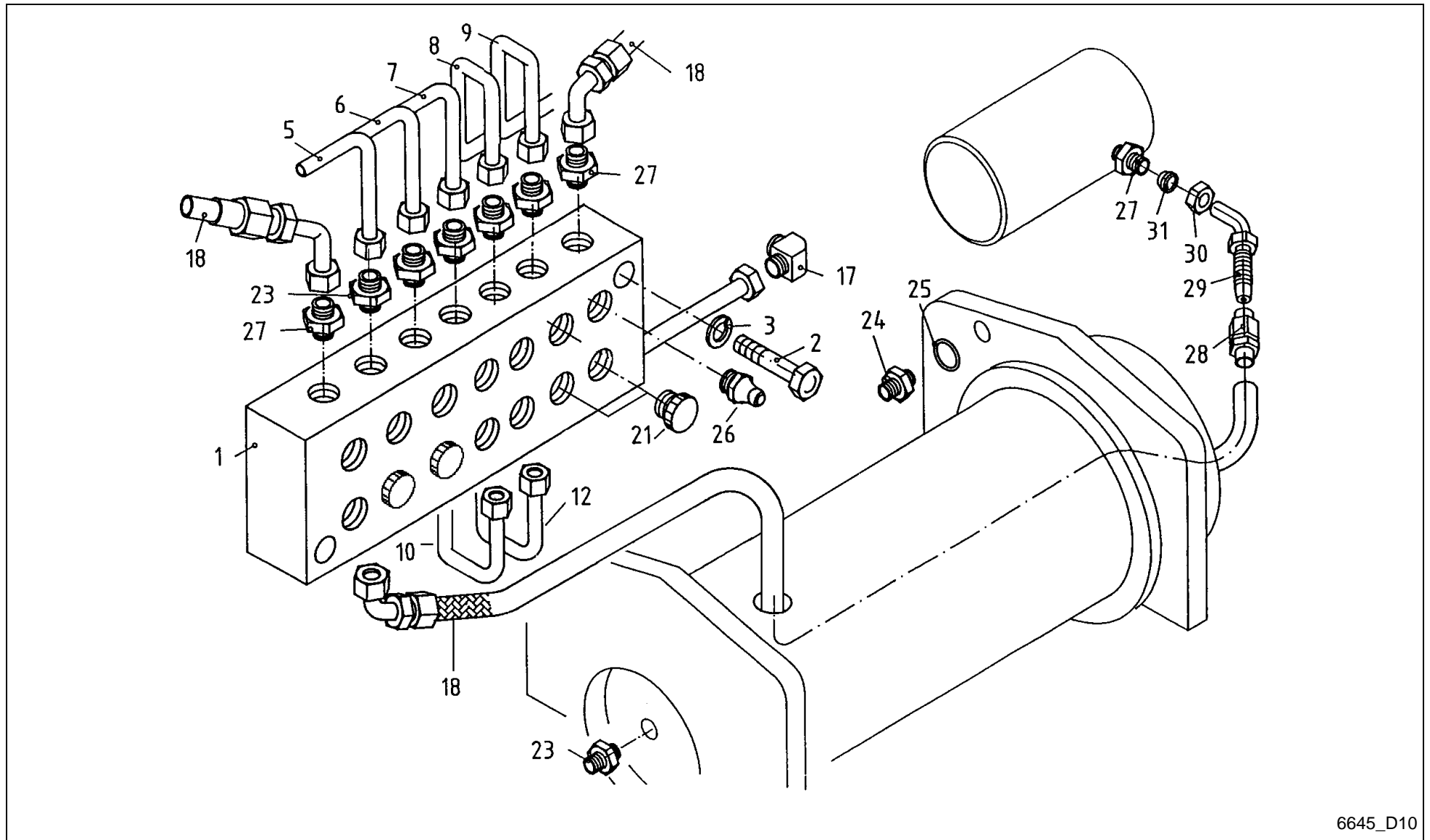

6645_D10

Alpex 280 / LUBE SYSTEM DRUM WITH 3 RAKES



PosNo.	Part No.	Qty.	Description	Remark
1	VF16516677	1	STRIP	
2	VF01122389	2	HEX.HEAD SCREW	
3	VF01102797	2	SPRING WASHER	
5	A143043400	1	LUBRICATION TUBE 3R L=1028MM	
6	A143043500	1	LUBRICATION TUBE 3R L=1215MM	
7	A143043600	1	LUBRICATION TUBE 3R L=1375MM	
8	A143043700	1	LUBRICATION TUBE 3R L=507MM	
9	A143043800	1	LUBRICATION TUBE 3R L=435MM	
10	A143043900	1	LUBRICATION TUBE 3R L=1380MM	
12	A143044000	1	LUBRICATION TUBE 3R L=435MM	
17	VF06216854	1	ANGULAR UNION	
18	VF16610926	3	LUBE HOSE	
21	VF06216527	8	PROTECTING PLUG	
23	VF06216815	10	NIPPLE	
24	VF01397760	3	SOCKET/ADAPTER	
25	VF01163589	3	O-RING	
26	VF01120693	10	GREASE FITTING H1 AM 8X1 DIN 71412	
27	VF01397933	6	SOCKET/ADAPTER	
28	VF16516717	3	SCREW SLEEVE	
29	VF16518135	3	PIPE SOCKET	
30	VF01100982	3	UNION NUT	
31	VF01292484	3	SEALING	

Alpex 280 / LUBE SYSTEM DRUM WITH 4 RAKES

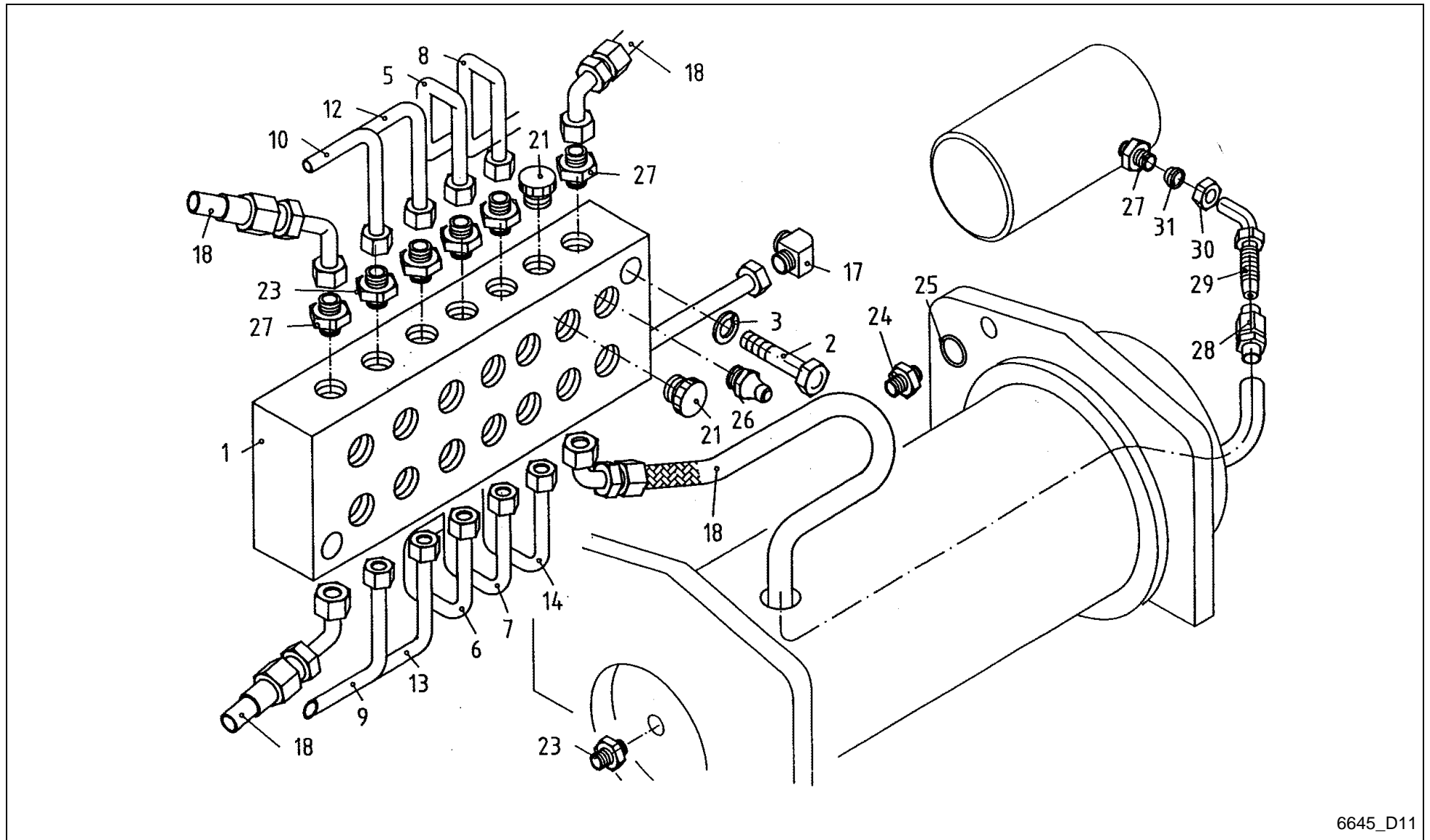

6645_D11

Alpex 280 / LUBE SYSTEM DRUM WITH 4 RAKES



PosNo.	Part No.	Qty.	Description	Remark
1	VF16516677	1	STRIP	
2	VF01122389	2	HEX.HEAD SCREW	
3	VF01102797	2	SPRING WASHER	
5	VF16516696	1	LUBE TUBE	RECHENLAGER
6	VF16516699	1	LUBE TUBE	RECHENLAGER
7	VF16516700	1	LUBE TUBE	RECHENLAGER
8	VF16516701	1	LUBE TUBE	RECHENLAGER
9	VF16516702	1	LUBE TUBE	FLANSCHZAPFEN
10	VF16516705	1	LUBE TUBE	FLANSCHZAPFEN
12	VF16516706	1	LUBE TUBE	FLANSCHZAPFEN
13	VF16516707	1	LUBE TUBE	FLANSCHZAPFEN
14	VF16516708	1	LUBE TUBE	TROMMELLAGER
17	VF06216854	1	ANGULAR UNION	
18	VF16610926	4	LUBE HOSE	
21	VF06216527	2	PROTECTING PLUG	
23	VF06216815	14	NIPPLE	
24	VF01397760	4	SOCKET/ADAPTER	
25	VF01163589	4	O-RING	
26	VF01120693	13	GREASE FITTING H1 AM 8X1 DIN 71412	
27	VF01397933	8	SOCKET/ADAPTER	
28	VF16516717	4	SCREW SLEEVE	
29	VF16518135	4	PIPE SOCKET	
30	VF01100982	4	UNION NUT	
31	VF01292484	4	SEALING	

Alpex 280 / GREEN FODDER SUPERSTRUCTURE, SUPPORTS

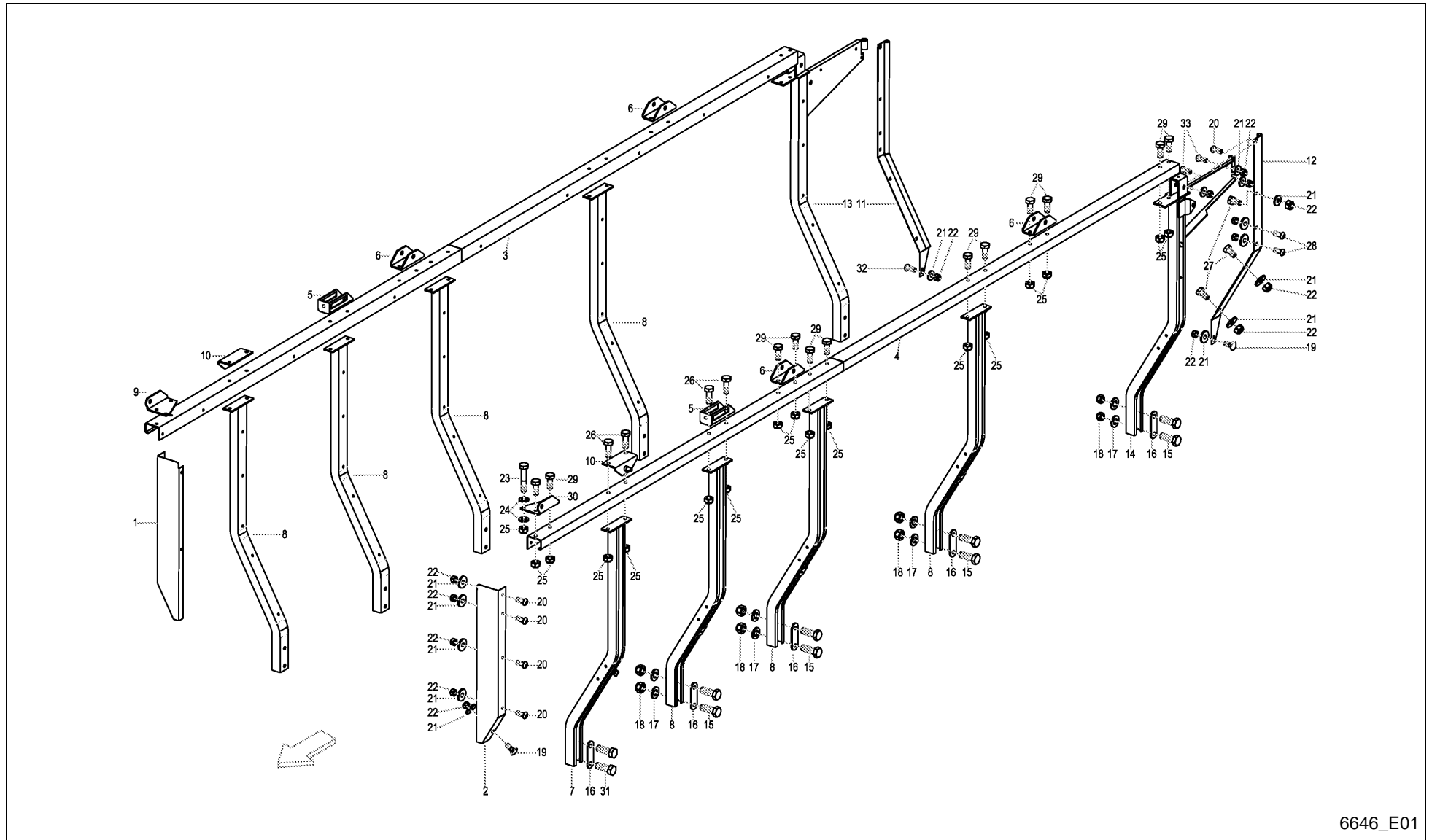

6646_E01

Alpex 280 / GREEN FODDER SUPERSTRUCTURE, SUPPORTS



PosNo.	Part No.	Qty.	Description	Remark
1	VF16631606	1	CORNER PLATE RIGHT	
2	VF16631605	1	CORNER PLATE LEFT	
3	VF16631832	1	CROSS BAR RIGHT	
4	VF16631831	1	CROSS BAR LEFT	
5	VF16630974	2	ANCHOR WALER WELDED	
6	VF16631636	4	RETAINER	
7	VF16631678	1	SUPPORT SIDE WALL	
8	VF16631559	7	SIDE WALL SUPORT	
9	VF16631829	1	CORNER BRACKET RIGHT	
10	VF16631647	2	ANGLE BRACKET, WELDED	
11	VF16631564	1	SIDEBAR RIGHT	
12	VF16631563	1	SIDEBAR LEFT	
13	VF16631562	1	SUPPORT RIGHT WELDED	
14	VF16631561	1	SUPPORT LEFT WELDED	
15	VF01112538	16	HEX.HEAD SCREW	
16	VF16631587	10	PANEL,	
17	VF06214207	16	WASHER	
18	VF06209769	16	LOCK NUT	
19	VF06207534	3	SCREW	
20	VF01142565	10	TRUSS-HEAD SCR. M8X20 109 GALV.	
21	VF06214192	26	WASHER 8,4X25X3 GALV.	
22	VF01104944	26	NY LOCK NUT 8A3CD985	
23	VF01111315	2	HEX.HEAD SCREW	
24	VF01107103	4	WASHER/DISC/PLATE	
25	VF06209768	34	LOCK NUT	
26	VF01112429	8	HEX. HEAD SCREW	
27	VF06207535	6	OVAL HEADED BOLT	
28	VF01142856	4	CUP SQR. BOLT M8X25DIN7380-2 10.9 GALV.	
29	VF01112418	24	BOLT, SCREW	
30	VF16631828	1	CORNER BRACKET LEFT	
31	VF06209459	4	SCREW M12X35D933 8.8 A3C DIN267-27 COATE	
32	VF01137624	1	SCREW	
33	VF01141006	4	TRUSS-HEAD SCR. M8X16 109 GALV.	

Alpex 280 / GREEN FODDER SUPERSTRUCTURE - SIDE PANELS

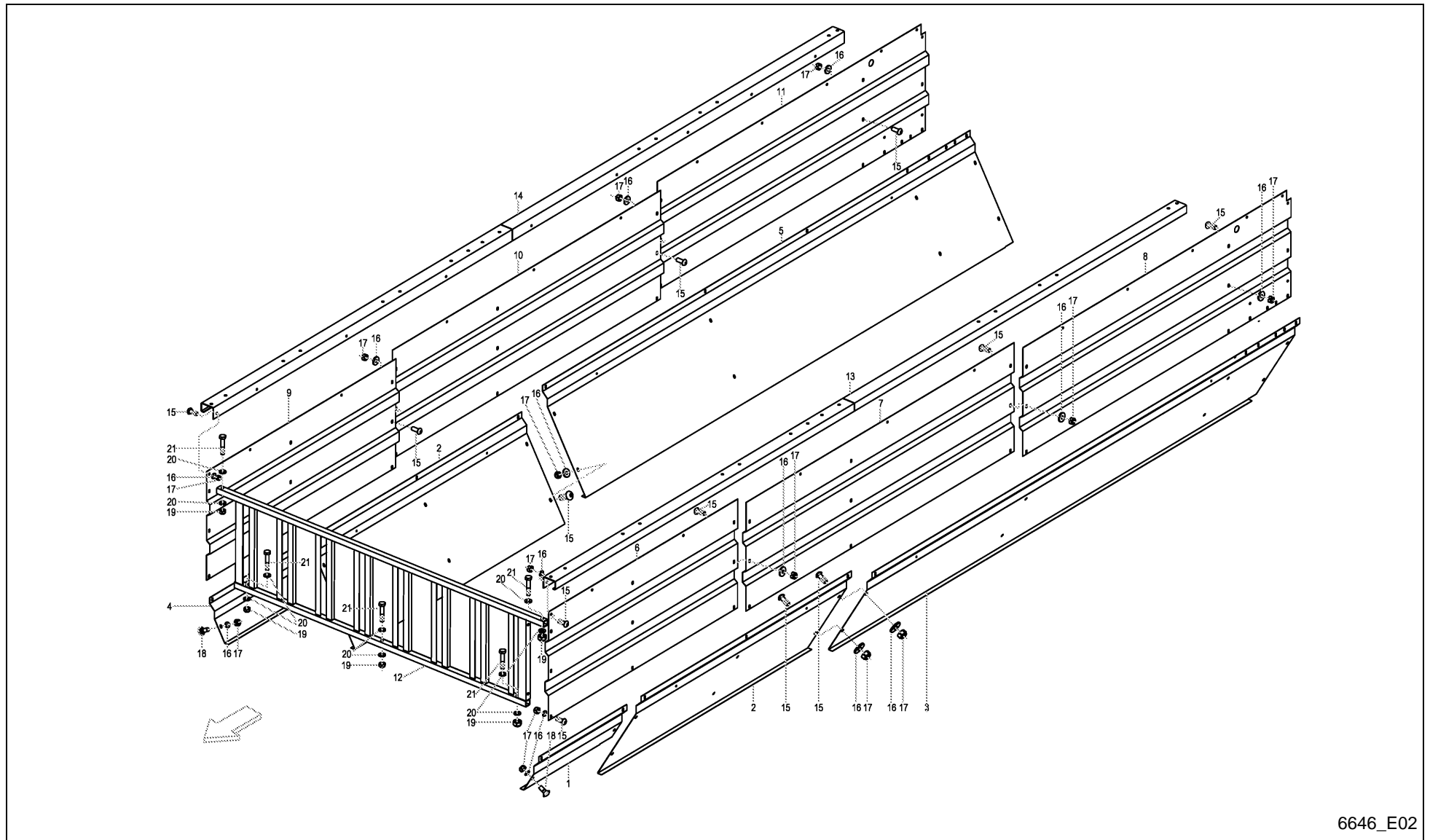

6646_E02

Alpex 280 / GREEN FODDER SUPERSTRUCTURE - SIDE PANELS



PosNo.	Part No.	Qty.	Description	Remark
1	A143028394	1	SIDE PANEL LEFT,	
2	A143029594	2	SIDE PANEL BELOW FRONT	
3	A143029694	1	SIDE PANEL LEFT BELOW REAR	
4	A143028694	1	SIDE PANEL RIGHT,	
5	A143029794	1	SIDE PANEL RIGHT BELOW REAR	
6	A143029894	1	SIDE PANEL LEFT FRONT UP	
7	A143029994	1	SIDE PANEL LEFT MIDDLE UP	
8	A143030094	1	SIDE PANEL LEFT REAR UP	
9	A143030194	1	SIDE PANEL RIGHT FRONT UP	
10	A143030294	1	SIDE PANEL RIGHT MIDDLE UP	
11	A143030394	1	SIDE PANEL RIGHT REAR UP	
12	VF16631565	1	FRONT WALL TL	
13	VF16631831	1	CROSS BAR LEFT	
14	VF16631832	1	CROSS BAR RIGHT	
15	VF01142565	60	TRUSS-HEAD SCR. M8X20 109 GALV.	
16	VF06214192	60	WASHER 8,4X25X3 GALV.	
17	VF01104944	60	NY LOCK NUT 8A3CD985	
18	VF06207534	2	SCREW	
19	VF06209768	5	LOCK NUT	
20	VF01107103	10	WASHER/DISC/PLATE	
21	VF01111315	5	HEX.HEAD SCREW	

Alpex 280 / HYDR. ADJUSTEMENT OF BACK NET UNIT

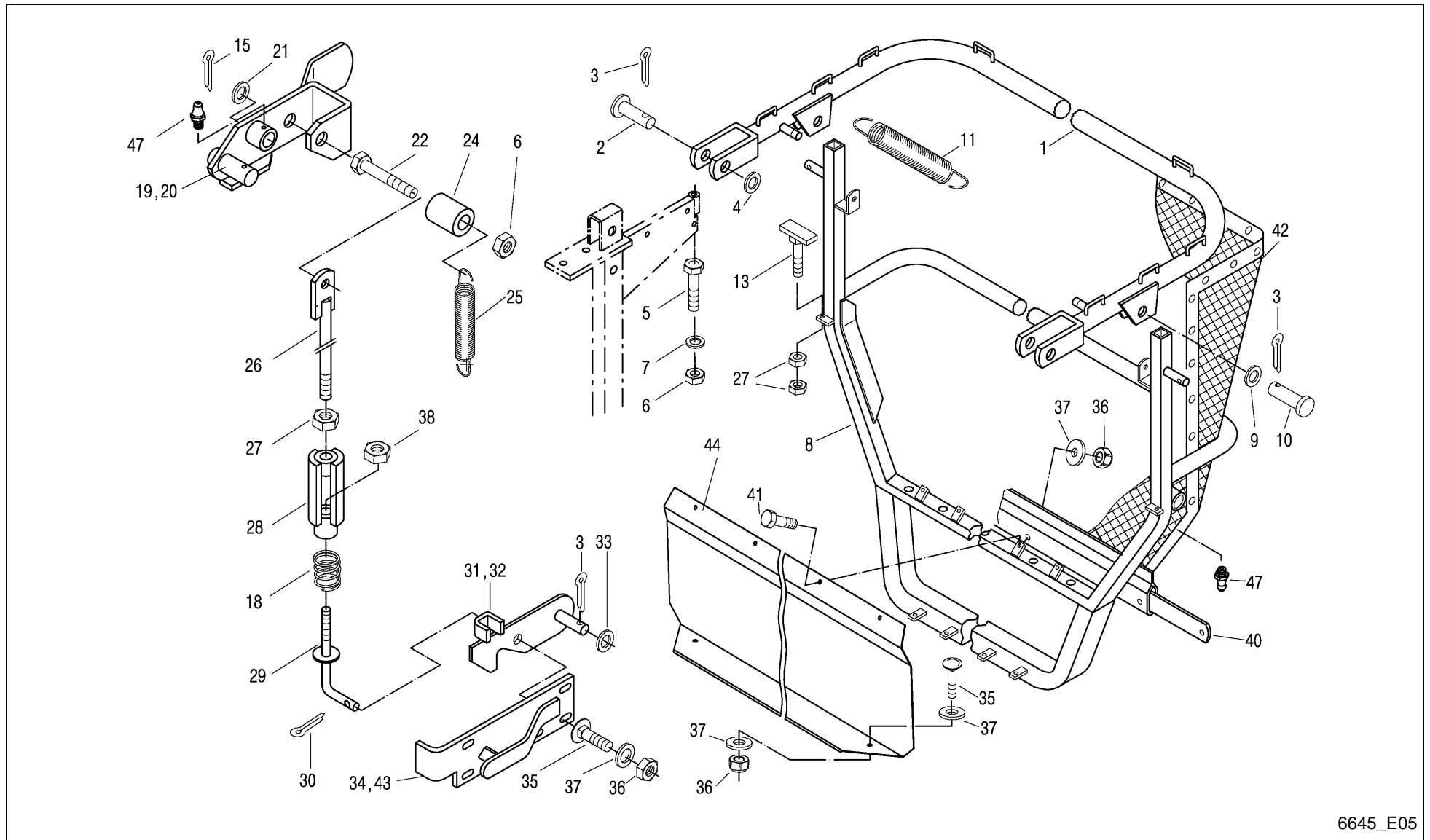

6645_E05



Alpex 280 / HYDR. ADJUSTEMENT OF BACK NET UNIT

PosNo.	Part No.	Qty.	Description	Remark
1	VF16631555	1	REAR PANEL BRACKET TL	
2	VF06210032	1	BOLT DIN1434-16H11X 70X 65 FE+ZN	
3	VF01106451	4	SPLIT PIN	
4	VF06214215	1	WASHER 18X30X1,5 GALV.	
5	VF01111514	2	HEX. HEAD SCREW	
6	VF06209769	4	LOCK NUT	
7	VF06214207	2	WASHER	
8	VF16631550	1	REAR PANEL	
9	VF06214218	2	WASHER	
10	VF01139468	2	PIN	
11	VF16611055	2	DRAW SPRING	
13	VF16630757	2	STOP	
15	VF01122072	2	SPLIT PIN	
18	VF06215315	2	COMPRESSION SPRING	
19	VF16611351	1	ADJUSTING LEVER	
20	VF16611352	1	ADJUSTING LEVER	
21	VF01115021	2	WASHER	
22	VF01111527	2	HEX. HEAD SCREW	
24	VF16611418	2	PIPE/TUBE	
25	VF16611054	2	DRAW SPRING	
26	VF16631556	2	TENSION ROD WELDED	
27	VF01102659	6	HEX. NUT	
28	VF16611341	2	TURNBUCKLE	
29	VF16611338	2	HOOK	
30	VF01132621	2	SPLIT PIN	
31	VF16611325	1	RATCHET/PAWL	
32	VF16611326	1	RATCHET/PAWL	
33	VF01124633	2	WASHER	
34	VF16611330	1	HINGED PIECE	
35	VF01142565	16	TRUSS-HEAD SCR. M8X20 109 GALV.	
36	VF01104944	22	NY LOCK NUT 8A3CD985	
37	VF06214192	19	WASHER 8,4X25X3 GALV.	
38	VF06209768	2	LOCK NUT	
40	A143023286	1	STRIP	
41	VF01112333	6	HEX. HEAD SCREW	
42	VF16631553	1	BACK NET	
43	VF16611331	1	HINGED PIECE	
44	A143029294	1	COVERING SHEET	
47	VF01120692	4	GREASE NIPPLE H1 AM 6X1 DIN 71412	

Alpex 280 / DRY FORAGE SUPERSTRUCTURE

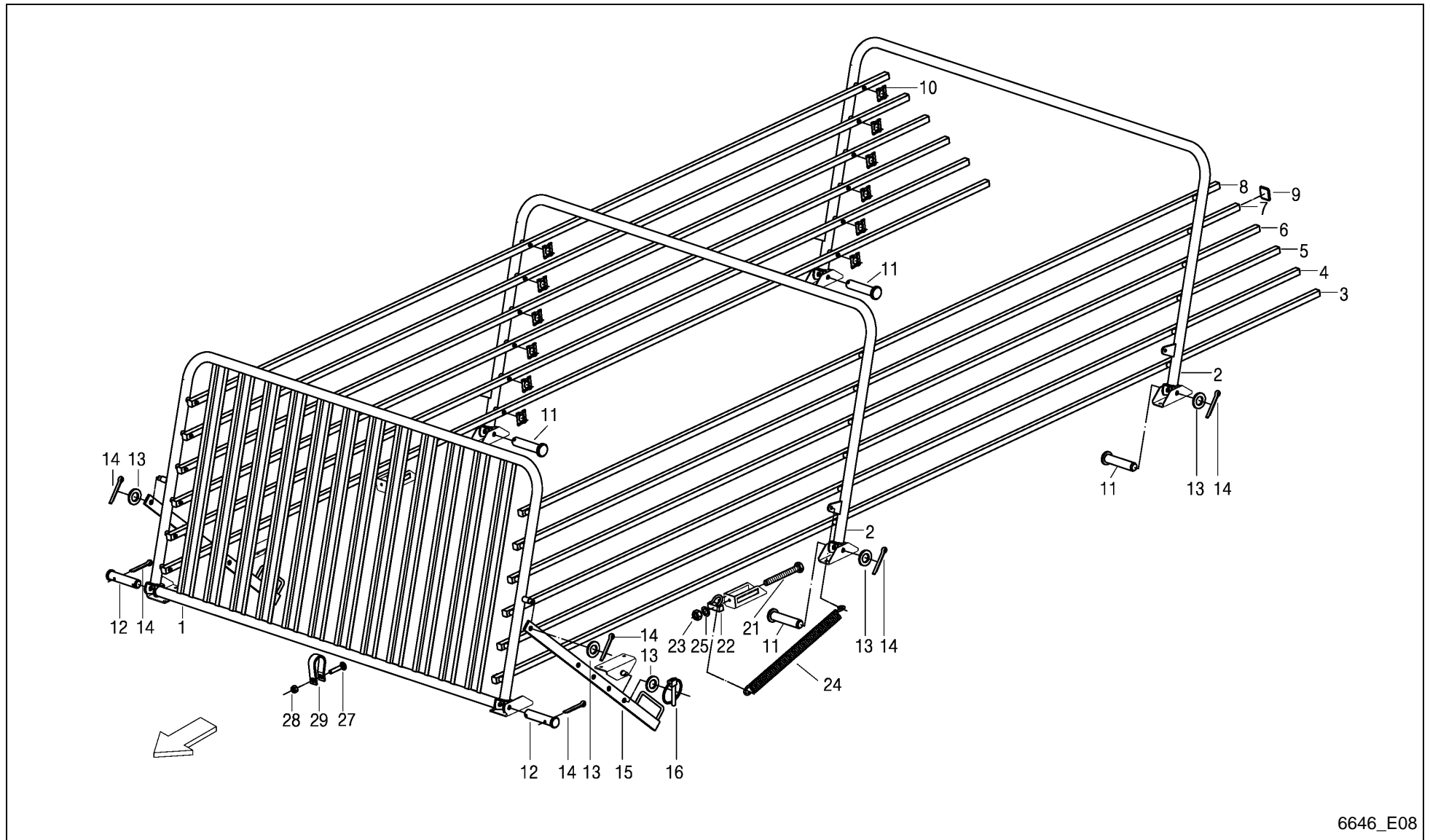

6646_E08

Alpex 280 / DRY FORAGE SUPERSTRUCTURE



PosNo.	Part No.	Qty.	Description	Remark
1	VF16631835	1	FRONT WALL	
2	VF16631635	2	YOKE	
3	VF16631778	2	TUBE PROFILE TL28	
4	VF16631779	2	TUBE PROFILE TL28	
5	VF16631781	2	TUBE PROFILE TL28	
6	VF16631782	2	TUBE PROFILE TL28	
7	VF16631783	2	TUBE PROFILE TL28	
8	VF16631784	2	TUBE PROFILE TL28	
9	VF16611490	24	SQUARE PLUG	
10	VF06214633	36	SEEGER RING	
11	VF01139468	4	PIN	
12	VF16631834	2	PIN	
13	VF06214295	8	WASHER 17,0X34,0X3,0 DIN 134	
14	VF01106451	6	SPLIT PIN	
15	VF16631848	2	ADJUSTING LEVER	
16	VF16611321	2	LYNCH PIN 4X27 DIN11023 GALV.	
21	VF16630982	2	HEXAGON HEAD SCREW M10X120 D933 8.8	
22	VF16630980	2	CLAMPING YOKE WELDED	
23	VF01102659	2	HEX. NUT	
24	VF01142492	2	DRAW SPRING	
25	VF01107103	2	WASHER/DISC/PLATE	
27	VF16631789	1	TRUSS-HEAD SCREW M10X60 D603 8.8	
28	VF06209768	1	LOCK NUT	
29	VF16631914	1	YOKE PARK BRAKE	

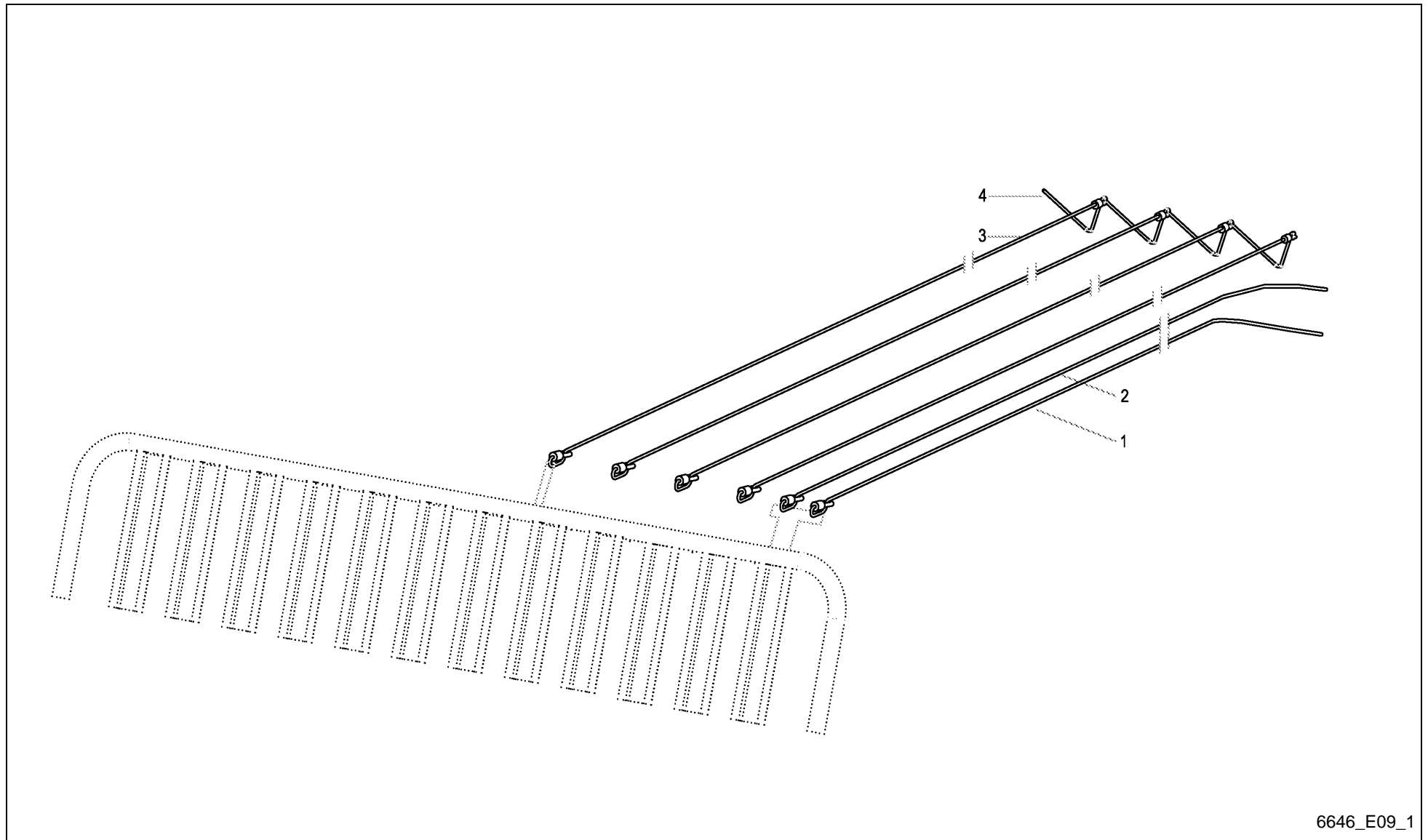

6646_E09_1

Alpex 280 / DRY FORAGE SUPERSTRUCTURE NET AND CORD (-A 2007)



PosNo.	Part No.	Qty.	Description	Remark
1	VF16613470	2	CABLE/ROPE	
2	VF16613469	2	CABLE/ROPE	
3	VF06587310	10	ROPE	
4	VF16630219	1	CORD PE 6X20000MM	

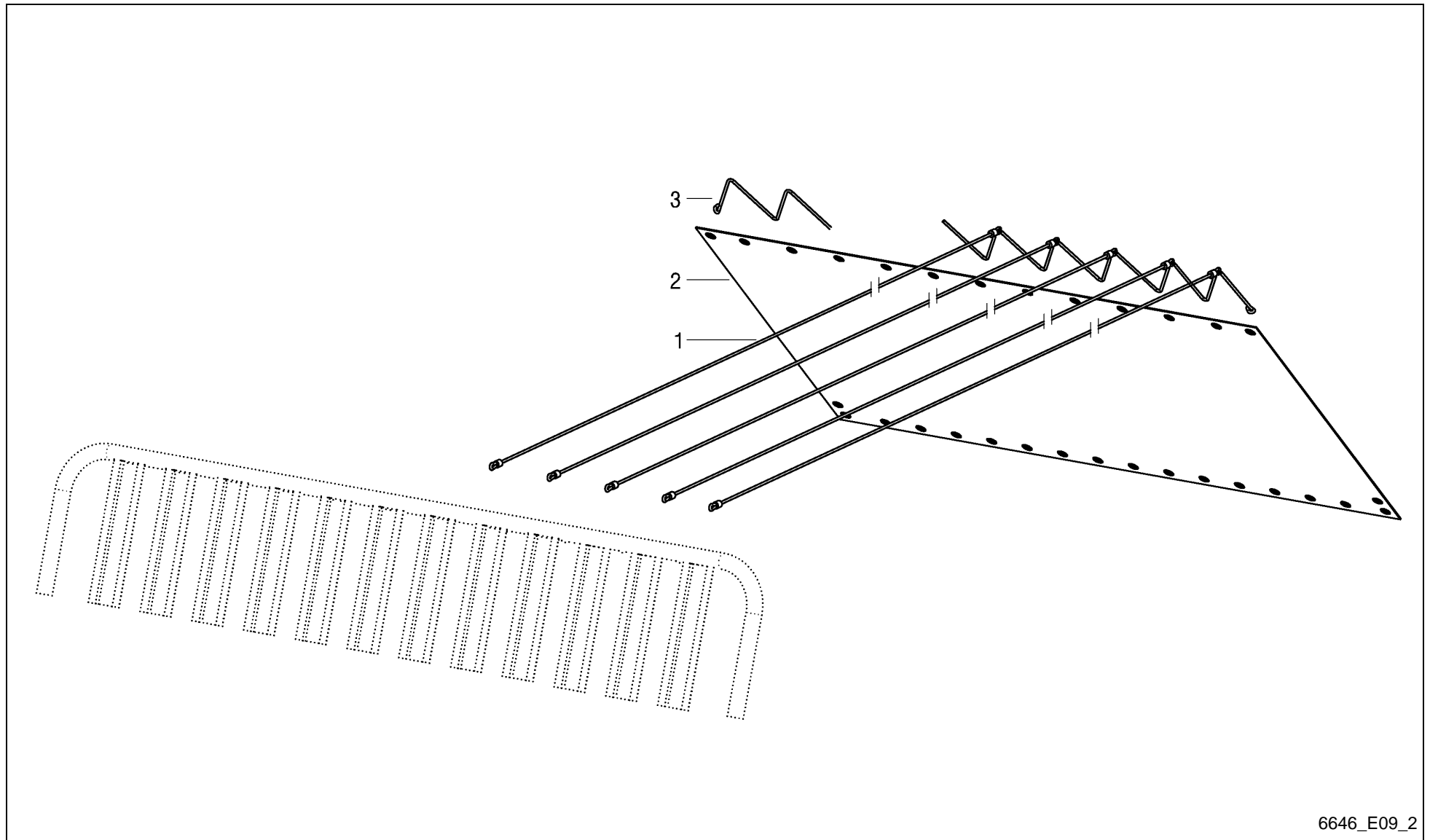

6646_E09_2

Alpex 280 / DRY FORAGE SUPERSTRUCTURE NET AND CORD (+A 2008)



PosNo.	Part No.	Qty.	Description	Remark
1	VF16631888	12	CORD SEIL PE 6X3700MM (2 ÖSEN)	
2	A143043200	1	NET	
3	VF16630219	1	CORD PE 6X20000MM	

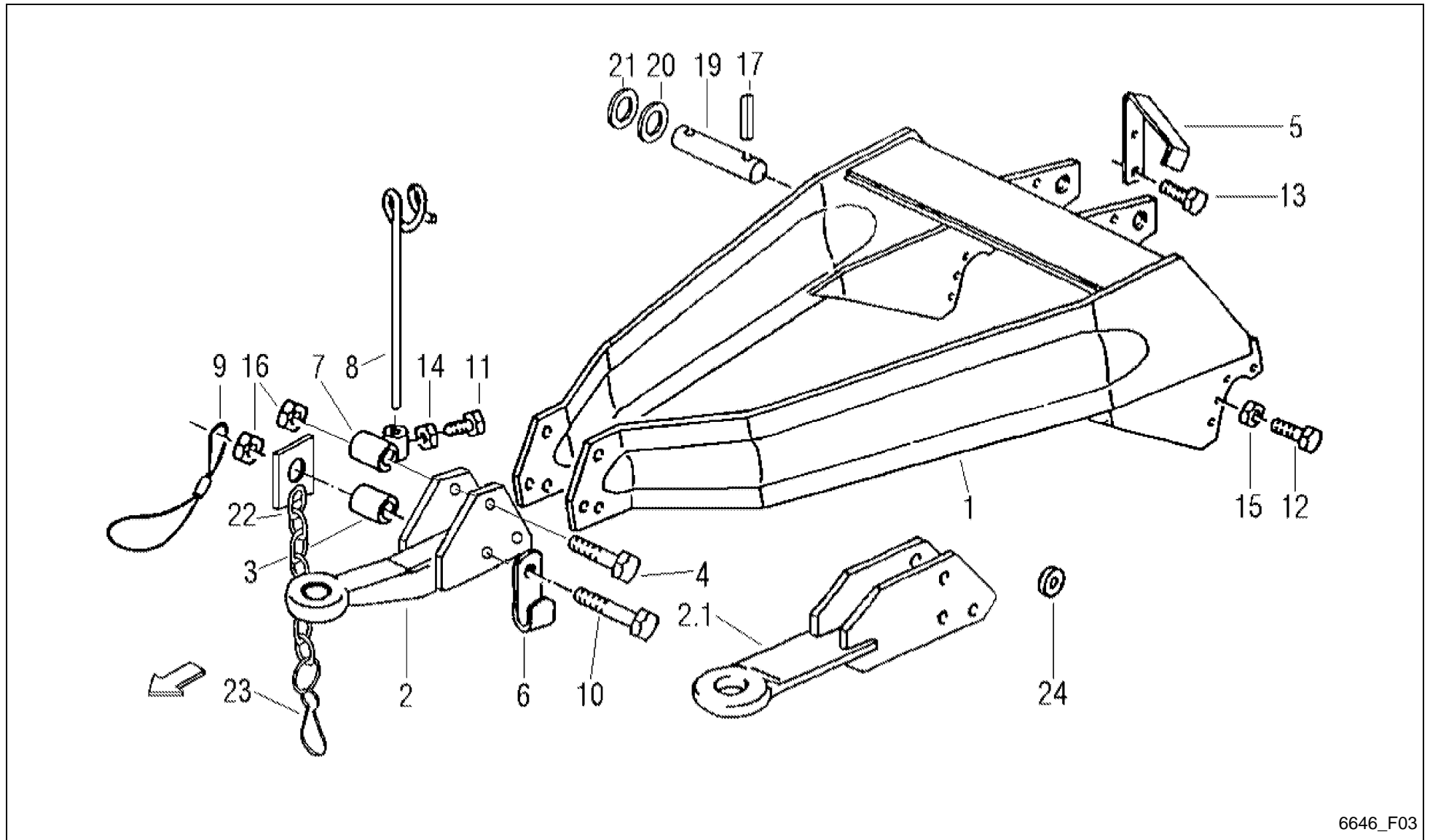

6646_F03

Alpex 280 / DRAWBAR Z 400 (-0180)



PosNo.	Part No.	Qty.	Description	Remark
1	VF06554513	1	DRAWBAR	
2	VF16631460	1	TRACTION EYE	
2.1	VF16613273	1	DRAWBAR EYE	
3	VF16631478	1	PIPE	
4	VF16630549	1	HEXAGON HEAD SCREW M20X130 DIN931 10.9	
5	VF06558560	1	CLAMPING PIECE	
6	VF06558561	1	ANGLE	
7	VF06558562	1	TUBE	
8	VF06558569	1	SUPPORT	
9	VF06587235	1	SAFETY CABLE	
10	VF06209165	1	HEX. HEAD SCREW	
11	VF01112307	1	HEX. HEAD SCREW	
12	VF01112687	4	HEX. HEAD SCREW	
13	VF06209473	2	BOLT M8X16 D933 8.8 A3C DIN267-27 COATE	
14	VF01112824	1	HEX. NUT	
15	VF01127856	4	LOCK NUT	
16	VF06209774	2	LOCK NUT	
17	VF01115478	2	DOWEL PIN	
19	VF06554790	1	PIN	
20	VF01137526	2	WASHER	
21	VF06214486	1	SPACER 35X45X1,0 D988	
22	VF16611433	1	CHAIN	
23	VF06211876	1	SNAP HOOK C60 D5299 GALV.	
24	VF06214226	4	WASHER	
25	VF01120692	1	GREASE NIPPLE H1 AM 6X1 DIN 71412	

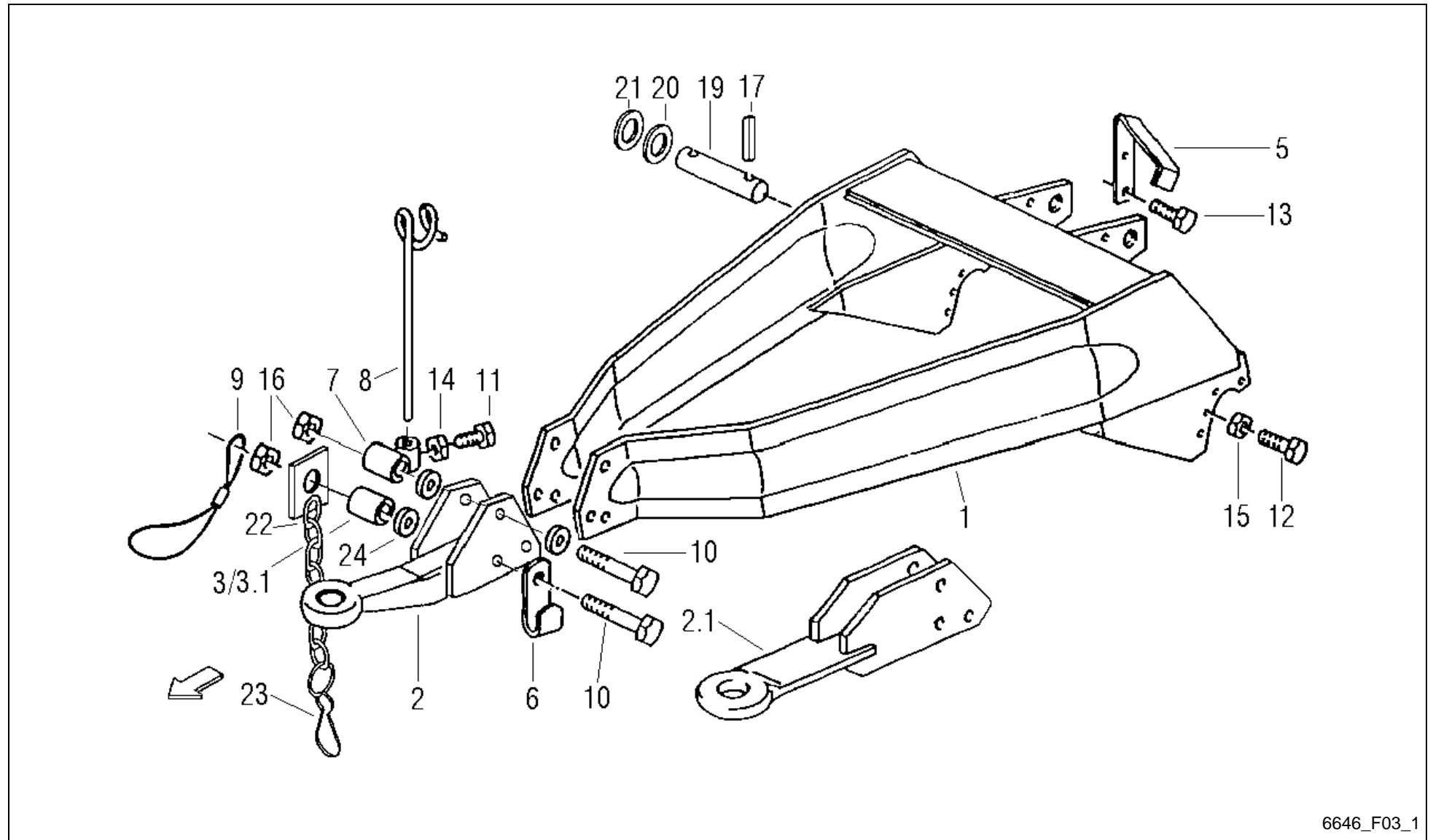

6646_F03_1



Alpex 280 / DRAWBAR Z 450 (+0181)

PosNo.	Part No.	Qty.	Description	Remark
1	VF16513246	1	DRAWBAR	
2	VF16631460	1	TRACTION EYE	
2.1	VF16613273	1	DRAWBAR EYE	
3	VF06554525	1	TUBE	
3.1	VF16631478	1	PIPE	
5	VF06558560	1	CLAMPING PIECE	
6	VF06558561	1	ANGLE	
7	VF06558562	1	TUBE	
8	VF06558569	1	SUPPORT	
9	VF06587235	1	SAFETY CABLE	
10	VF01136666	2	HEX. HEAD SCREW	
11	VF01112307	1	HEX. HEAD SCREW	
12	VF01112687	4	HEX. HEAD SCREW	
13	VF06209473	2	BOLT M8X16 D933 8.8 A3C DIN267-27 COATE	
14	VF01112824	1	HEX. NUT	
15	VF01127856	4	LOCK NUT	
16	VF06209774	2	LOCK NUT	
17	VF01115478	2	DOWEL PIN	
19	VF06554790	1	PIN	
20	VF01137526	2	WASHER	
21	VF06214486	1	SPACER 35X45X1,0 D988	
22	VF16611433	1	CHAIN	
23	VF06211876	1	SNAP HOOK C60 D5299 GALV.	
24	VF06214226	3	WASHER	
25	VF01120692	1	GREASE NIPPLE H1 AM 6X1 DIN 71412	

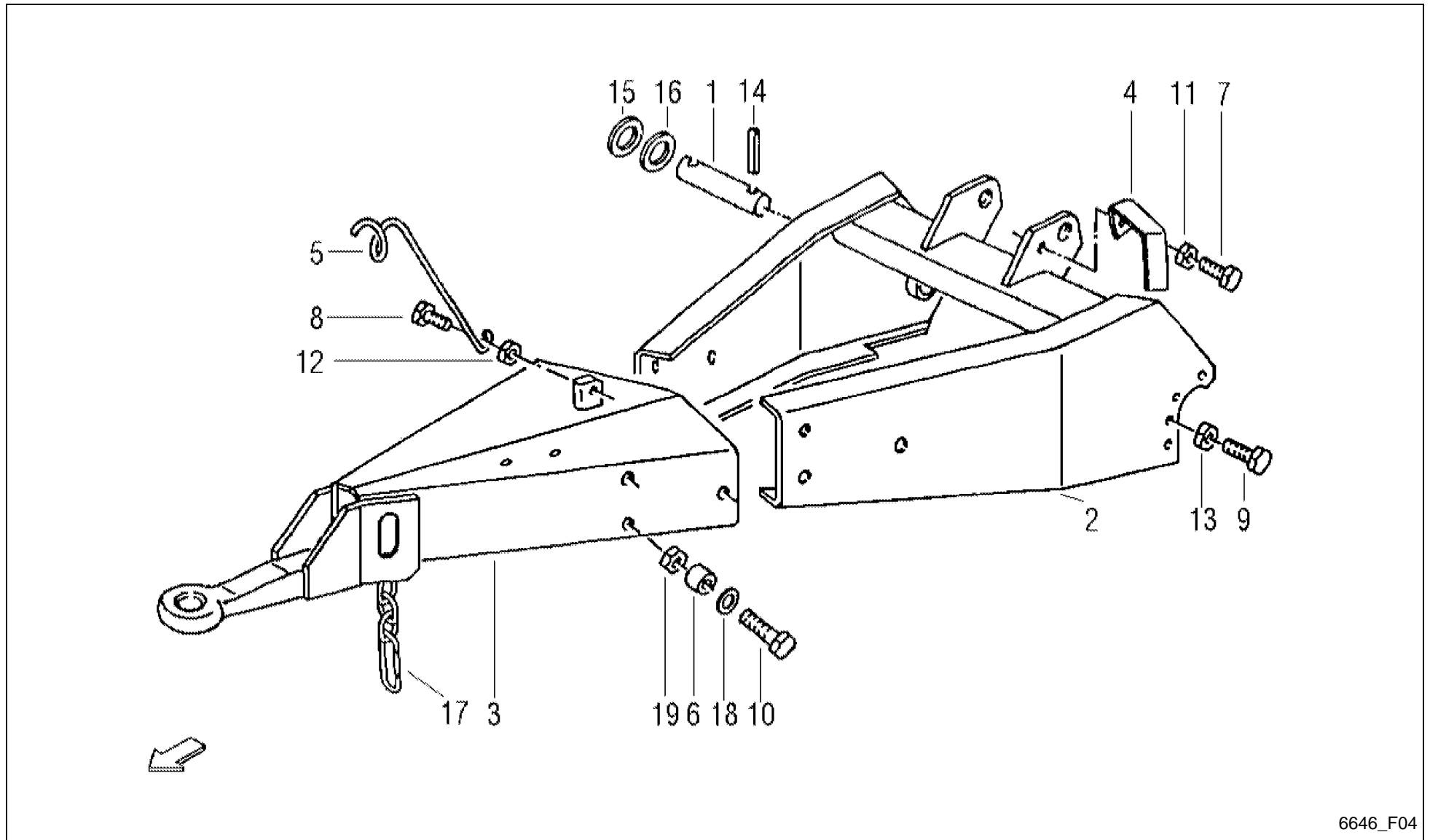

6646_F04

Alpex 280 / DRAWBAR Z 800 (-0180)



PosNo.	Part No.	Qty.	Description	Remark
1	VF06554790	1	PIN	
2	VF06554794	1	DRAWBAR	
3	VF06556268	1	TRACTION BAR	
4	VF16630283	1	CLAMPING PIECE	
5	VF06558567	1	SUPPORT	
6	VF06575227	6	SPACER RING	
7	VF01112333	1	HEX. HEAD SCREW	
8	VF01112418	1	BOLT, SCREW	
9	VF01112687	4	HEX. HEAD SCREW	
10	VF01111867	6	HEX.BOLT	
11	VF01104944	1	NY LOCK NUT 8A3CD985	
12	VF06209768	1	LOCK NUT	
13	VF01127856	4	LOCK NUT	
14	VF01115478	2	DOWEL PIN	
15	VF01137526	2	WASHER	
16	VF06214486	1	SPACER 35X45X1,0 D988	
17	VF16611356	1	CHAIN 4X32 20 LINKS + SNAP HOOK	
18	VF01142556	12	SPACING RING	
19	VF01100590	6	LOCK NUT	

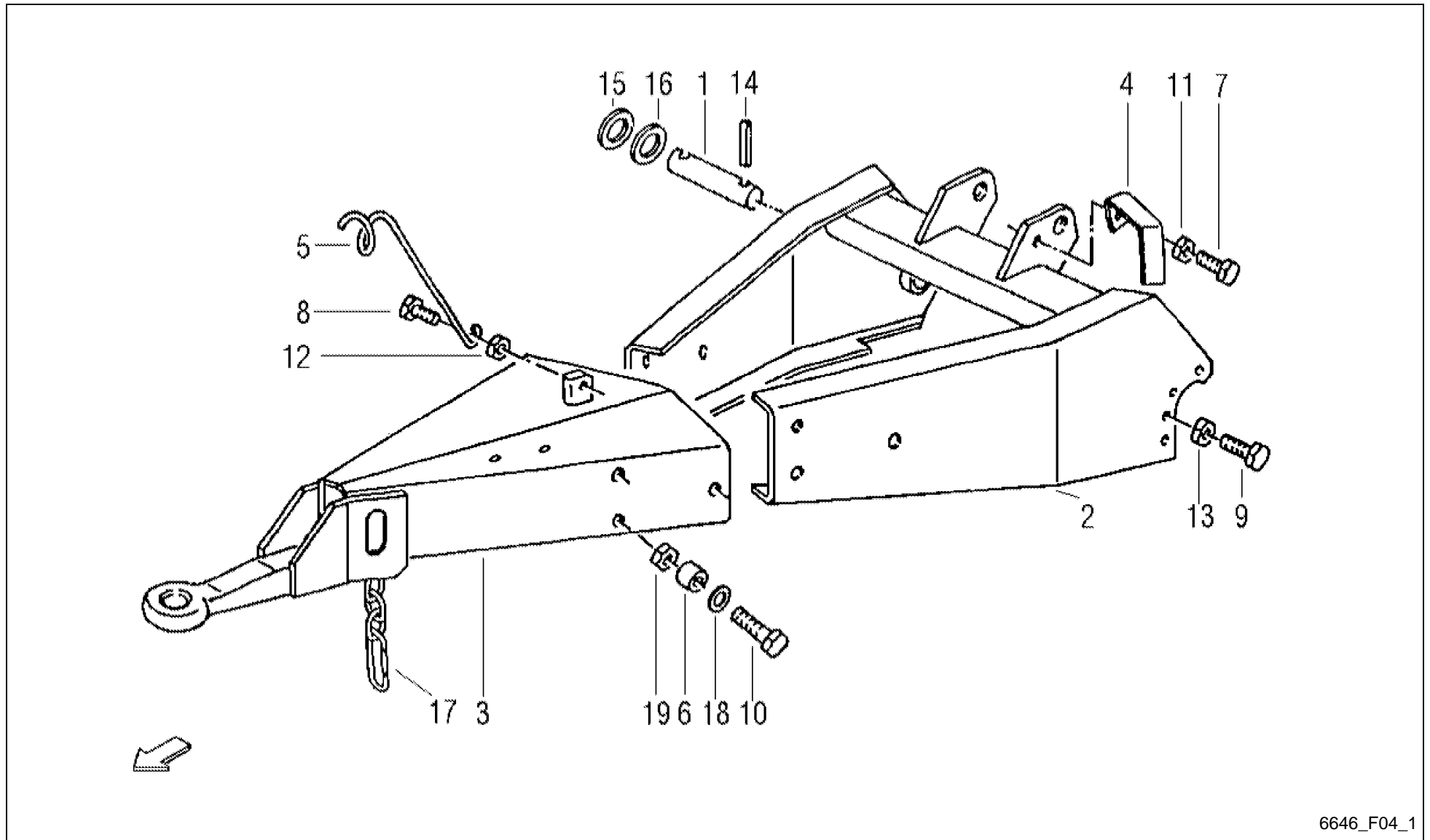

6646_F04_1

Alpex 280 / DRAWBAR Z 800 (+0181)



PosNo.	Part No.	Qty.	Description	Remark
1	VF06554790	1	PIN	
2	VF16631491	1	DEICHSEL GSW.	
3	VF06556268	1	TRACTION BAR	
4	VF16630283	1	CLAMPING PIECE	
5	VF06558567	1	SUPPORT	
6	VF06575227	6	SPACER RING	
7	VF01112333	1	HEX. HEAD SCREW	
8	VF01112418	1	BOLT, SCREW	
9	VF01112687	4	HEX. HEAD SCREW	
10	VF01111867	6	HEX.BOLT	
11	VF01104944	1	NY LOCK NUT 8A3CD985	
12	VF06209768	1	LOCK NUT	
13	VF01127856	4	LOCK NUT	
14	VF01115478	2	DOWEL PIN	
15	VF01137526	2	WASHER	
16	VF06214486	1	SPACER 35X45X1,0 D988	
17	VF16611356	1	CHAIN 4X32 20 LINKS + SNAP HOOK	
18	VF01142556	12	SPACING RING	
19	VF01100590	6	LOCK NUT	

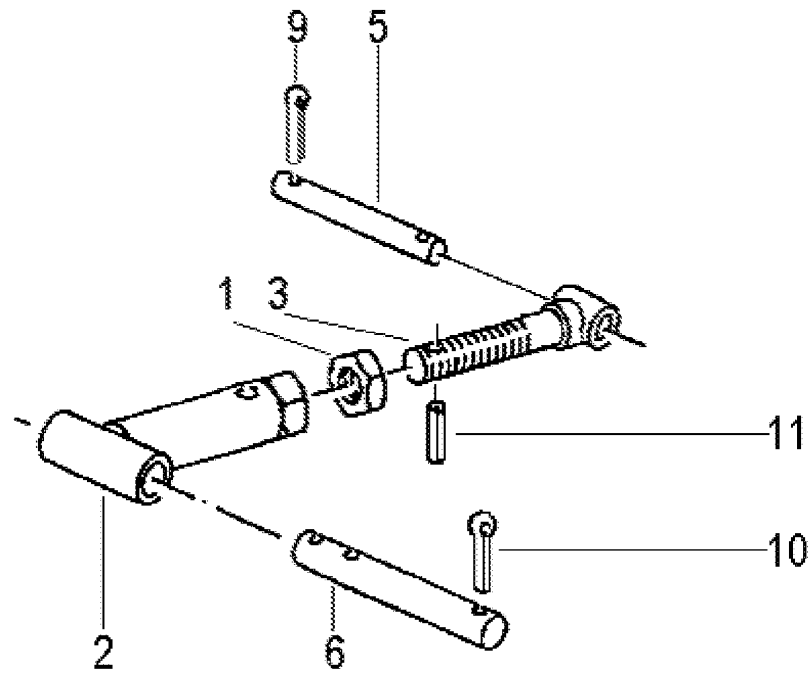

Alpex 280 / SPINDLE (-0180)



PosNo.	Part No.	Qty.	Description	Remark
1	VF01112972	1	HEX.NUT	
2	VF06554536	1	ADJUSTING SPINDLE	
3	VF06554540	1	THREADED SPINDLE	
5	VF16631685	1	BOLT D=25MM	
6	VF06554569	1	PIN	
9	VF01132647	2	SPLIT PIN	
10	VF01143009	2	SPLIT PIN	
11	VF01115438	1	DOWEL PIN	

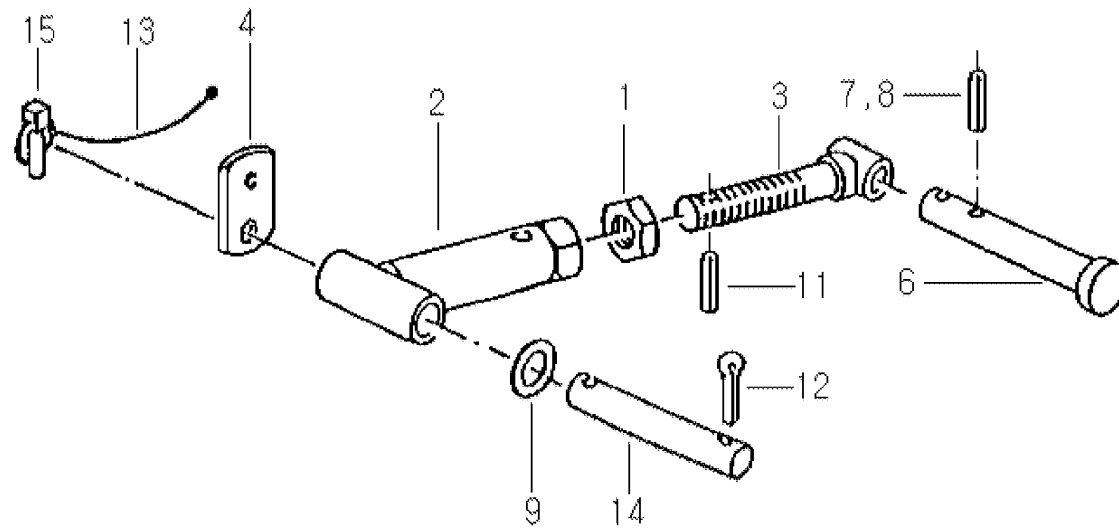



Alpex 280 / SPINDLE (+0181)

PosNo.	Part No.	Qty.	Description	Remark
1	VF01112972	1	HEX.NUT	
2	VF16517160	1	SPINDLE	
3	VF16517144	1	THREADED SPINDLE	
4	VF16517165	1	CONNECTING PLATE	
6	VF16635313	1	BOLT D=33MM	S D02_1 Pos. 15
7	VF01136930	1	DOWEL PIN	
8	VF01157345	1	DOWEL PIN	
9	VF06214238	2	WASHER 34X50X5 A2C DIN 1441	
11	VF01115438	1	DOWEL PIN	
12	VF01106500	1	SPLIT PIN 8X50DIN94 GALV.	
13	VF06564448	1	CORD L= 240 COLOUR BLACK	
14	VF01397597	1	PIN/BOLT/STUD	
15	VF06213664	1	FOLDING PLUG	

Alpex 280 / OVERR. DRAWBAR

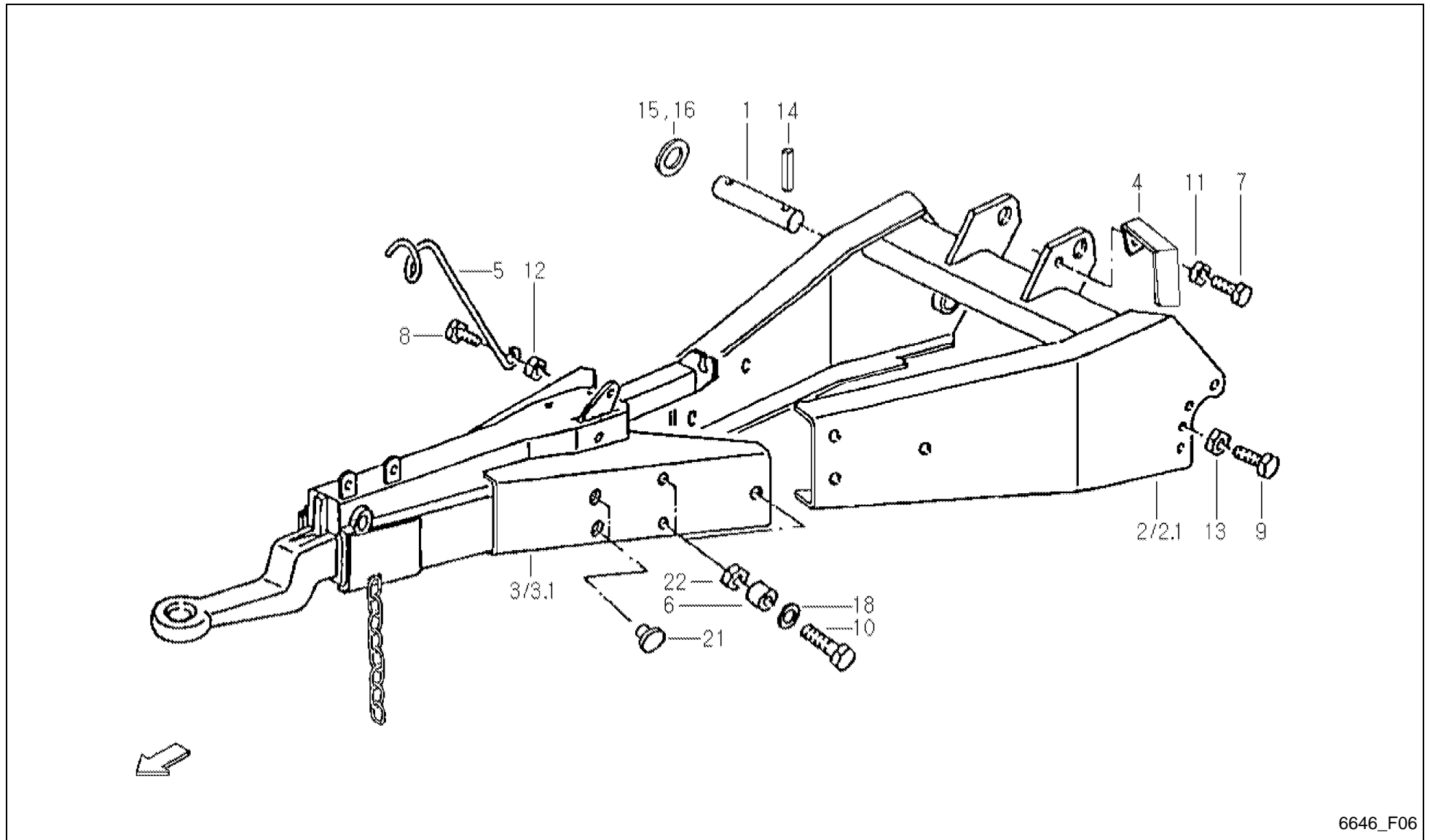

6646_F06



Alpex 280 / OVERR. DRAWBAR

PosNo.	Part No.	Qty.	Description	Remark
1	VF06554790	1	PIN	
2	VF06554794	1	DRAWBAR	-0180
2.1	VF16631491	1	DEICHSEL GSW.	+0181
3	VF16613360	1	OVERRUNNING DEVICE	
3.1	VF16630398	1	OVERRUNNING DEVICE	
4	VF06558565	1	CLAMPING PIECE	
5	VF06558567	1	SUPPORT	
6	VF06575227	6	SPACER RING	
7	VF01112333	1	HEX. HEAD SCREW	
8	VF01112418	1	BOLT, SCREW	
9	VF01112683	4	HEX.HEAD SCHREW	
10	VF01111867	6	HEX.BOLT	
11	VF01104944	1	NY LOCK NUT 8A3CD985	
12	VF06209768	1	LOCK NUT	
13	VF01127856	4	LOCK NUT	
14	VF01115478	2	DOWEL PIN	
15	VF01137526	1	WASHER	
16	VF06214486	1	SPACER 35X45X1,0 D988	
18	VF01142556	12	SPACING RING	
21	VF01097625	3	PLUG GPN300 F241	
22	VF01100590	6	LOCK NUT	

Alpex 280 / OVERRUNNING DEVICE AVEG 2000 BPW

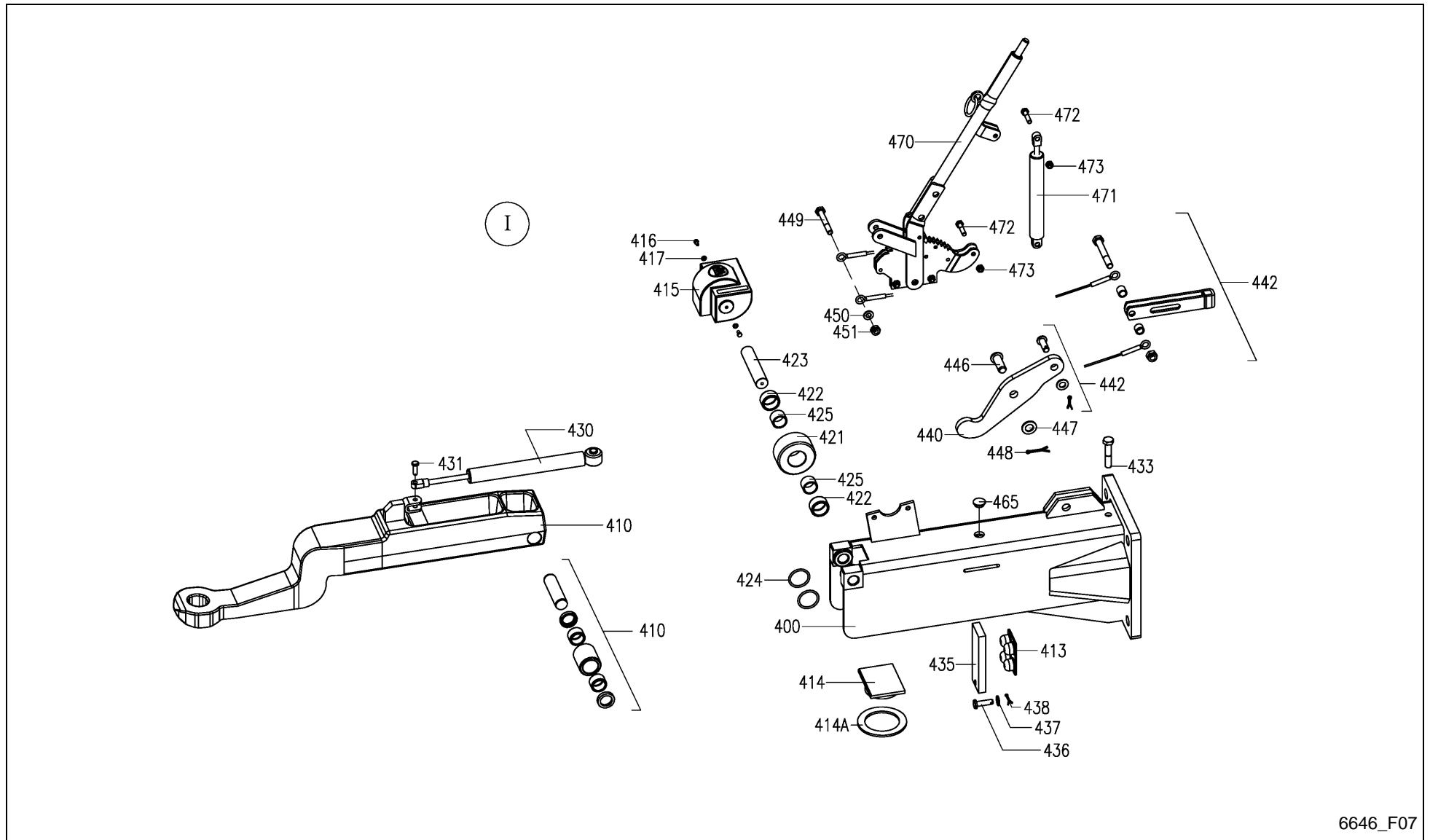

6646_F07



Alpex 280 / OVERRUNNING DEVICE AVEG 2000 BPW

PosNo.	Part No.	Qty.	Description	Remark
I	VF16630398	1	OVERRUNNING DEVICE	
400	A143517400	1	HOUSING	
410	VF16614457	1	PULLROD	
413	VF16614464	1	ABSORBER	
414	A143517500	1	PLATE	
414A	A143517600	1	WASHER 100/71X0,5-4,0	
415	VF16614458	1	CAP	
416	A143517700	2	HEXAGON HEAD SCREW M5X10 DIN933 8.8	
417	A143517800	2	WASHER 5,3 DIN125 200 HV	
421	VF16614459	1	ROLLER	
422	A143517900	2	NEEDLE SLEEVE HK3020 DIN618	
423	VF16614460	1	PIN	
424	A143518100	2	O-RING 35X4	
425	A143518200	2	INNER RING 25X30X20,5	
430	VF16614465	1	SHOCK ABSORBER	
431	VF16614461	1	PIN	
433	A143518300	1	HEXAGON HEAD SCREW M12X60 DIN931 8.8	
435	A143518400	1	PLATE	
436	A143518500	1	BOLT 10X35X31 DIN1434 ST	
437	A143466900	1	WASHER 10,5 DIN125 200HV	
438	A143485300	1	SPLIT PIN 3,2X16 ISO1234	
440	A143518600	1	DEFLEXION LEVER 120:85	
442	A143518700	1	BRAKE CABLE, COMPLETE	
446	A143518800	1	BOLT 16X45X38 DIN1434 ST	
447	A143518900	1	WASHER 17 DIN125 200 HV	
448	A143472600	1	SPLIT PIN 4X25 ISO1234	
449	A143519000	1	HEXAGON HEAD SCREW M10X75 DIN931 8.8	
450	A143466900	1	WASHER 10,5 DIN125 200HV	
451	A143467500	1	LOCK NUT VM10 DIN980	
465	VF16624942	1	PLUG	
470	A143519100	1	HAND BRAKE LEVER	
471	A143519200	1	DAMPER	
472	A143518000	2	HEXAGON HEAD SCREW M8X35 DIN933 8.8	
473	A143517100	2	LOCK NUT VM8 DIN980	

Alpex 280 / ELECTRICAL CONTROLLER ()

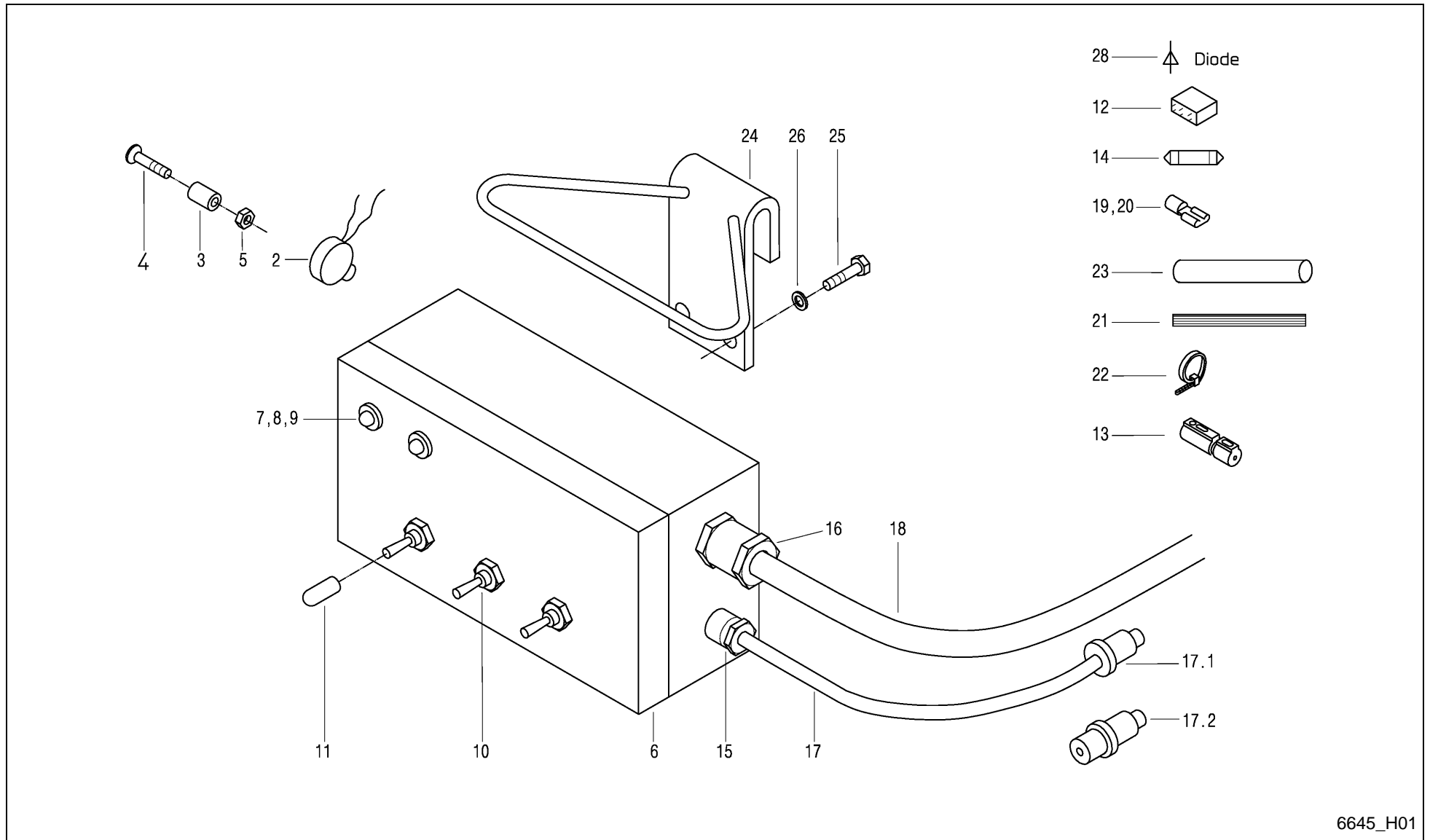

6645_H01



Alpex 280 / ELECTRICAL CONTROLLER ()

PosNo.	Part No.	Qty.	Description	Remark
1	VF16613394	1	PILOTBOX-T	
2	VF06579959	1	HORN	
3	VF06579960	2	SLEEVE	
4	VF01397550	2	C'SUNK SCREW	
5	VF01143097	2	HEX.NUT	
6	VF16613387	1	HOUSING/CASE	
7	VF16613236	1	RED LAMP	
8	VF16613237	1	GREEN LAMP	
9	VF16613238	2	O-RING	
10	VF06579979	3	TOGGLE SWITCH	
11	VF16515453	3	CAP	
12	VF01164017	1	RELAY	
13	VF06587052	1	SUPPORT	
14	VF01121330	1	FUSE	
15	VF06213737	1	UNION	
16	VF01151892	1	THREADED UNION	
17	VF06579961	1	CABLE	mit Pos. 17.1
17.1	VF01101600	1	PLUG	
17.2	VF16518524	1	PLUG CONTACT 3-POLE BIS 25A DIN 9680	alternativ zu Pos. 17.1
18	VF01142889	1	ELECTRIC LINES	
19	VF01397896	13	PLUG-IN SLEEVE	
20	VF01397920	15	PLUG-IN SLEEVE	
21	VF01403239	1	ELECTRIC LINES	
22	VF06216479	3	CABLE TIE 150X3,6 SW SNX 2-35	
23	VF16513942	1	SHRINK HOSE	
24	VF16515468	1	YOKE/RETAINER	
25	VF01112240	2	HEX. HEAD SCREW	
26	VF01118645	2	SEAL RING	
28	VF16511469	5	DIODE	

Alpex 280 / DISTRIBUTION BOX

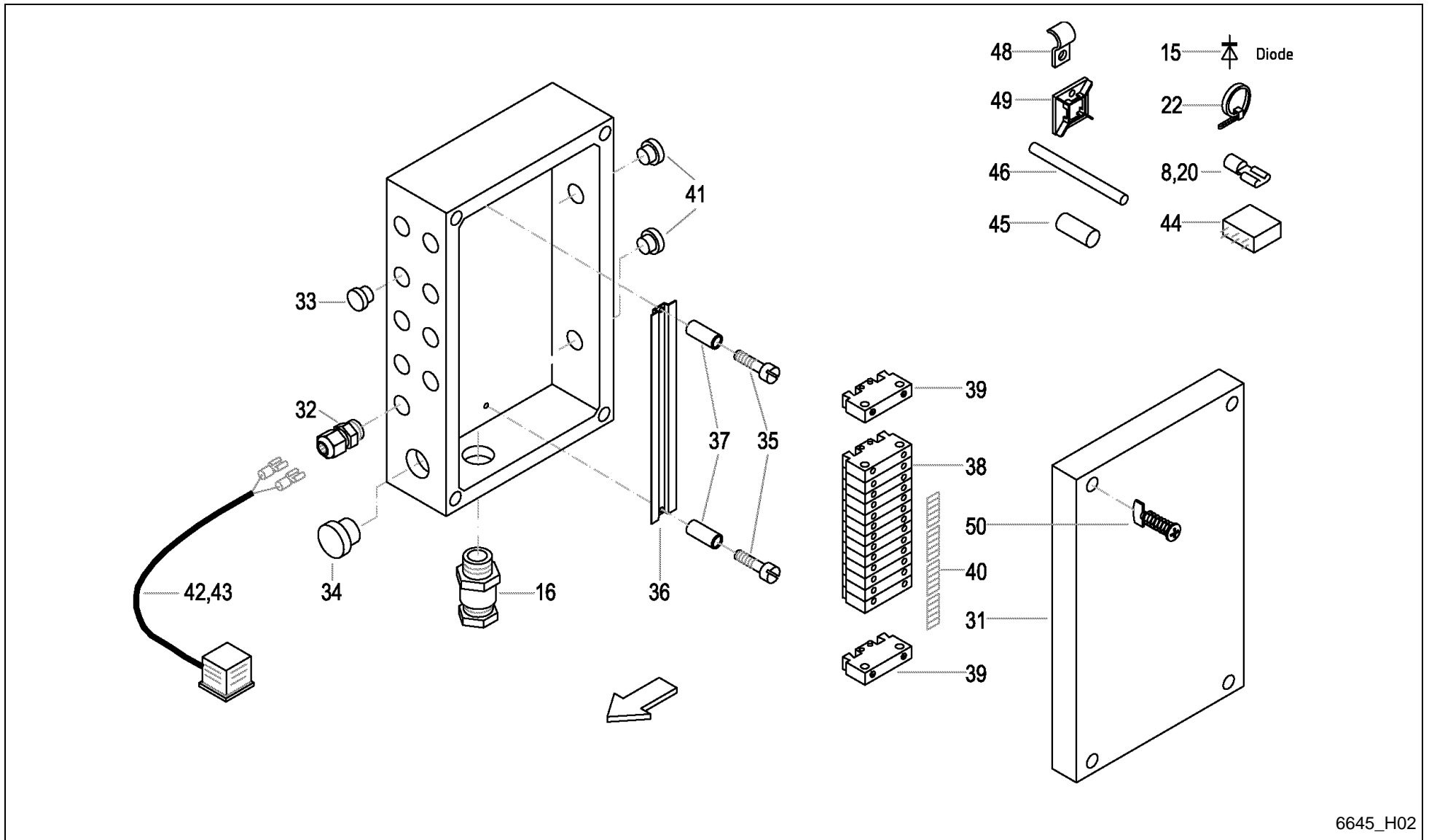

6645_H02



Alpex 280 / DISTRIBUTION BOX

PosNo.	Part No.	Qty.	Description	Remark
8	VF01397896	2	PLUG-IN SLEEVE	
15	VF16511469	5	DIODE	
16	VF01151892	1	THREADED UNION	
20	VF01397920	17	PLUG-IN SLEEVE	
22	VF06216479	13	CABLE TIE 150X3,6 SW SNX 2-35	
31	VF16517792	1	HOUSING	
31	VF16611275	4	QUICK FASTENER	
32	VF02953409	4	THREADED UNION	
33	VF01397704	5	BLANK PLUG	
34	VF02953408	1	BLANK PLUG	
35	VF01105571	2	CHEESE-HEAD SCREW	
36	VF16517922	1	SUPPORT RAIL	
37	VF16517923	2	SLEEVE	
38	VF16515446	14	TERMINAL	
39	VF16515448	2	END HOLDER	
40	VF16517917	1	LETTERING	
41	VF02953410	2	NIPPLE	
42	VF16518970	4	PIPE/LINE/LEAD	
42	VF01128192	6	CABLE END SOCKET	
42	VF06579981	3	TIN	
42	VF06579982	3	SECTIONAL SEAL	
43	VF16611079	3	INSCRIPTION PLATE	
44	VF16613243	1	RELAY	
45	VF16611081	1	SHRINK HOSE	
46	VF01404321	2	SHRINK HOSE	
48	VF06216397	2	FIXING CLIP	
49	VF16613283	2	CABLE RETAINER	
50	VF01397598	2	SELF-TAPPING SCREW	

Alpex 280 / ELECTR.EQUIPMENT LIGHTING

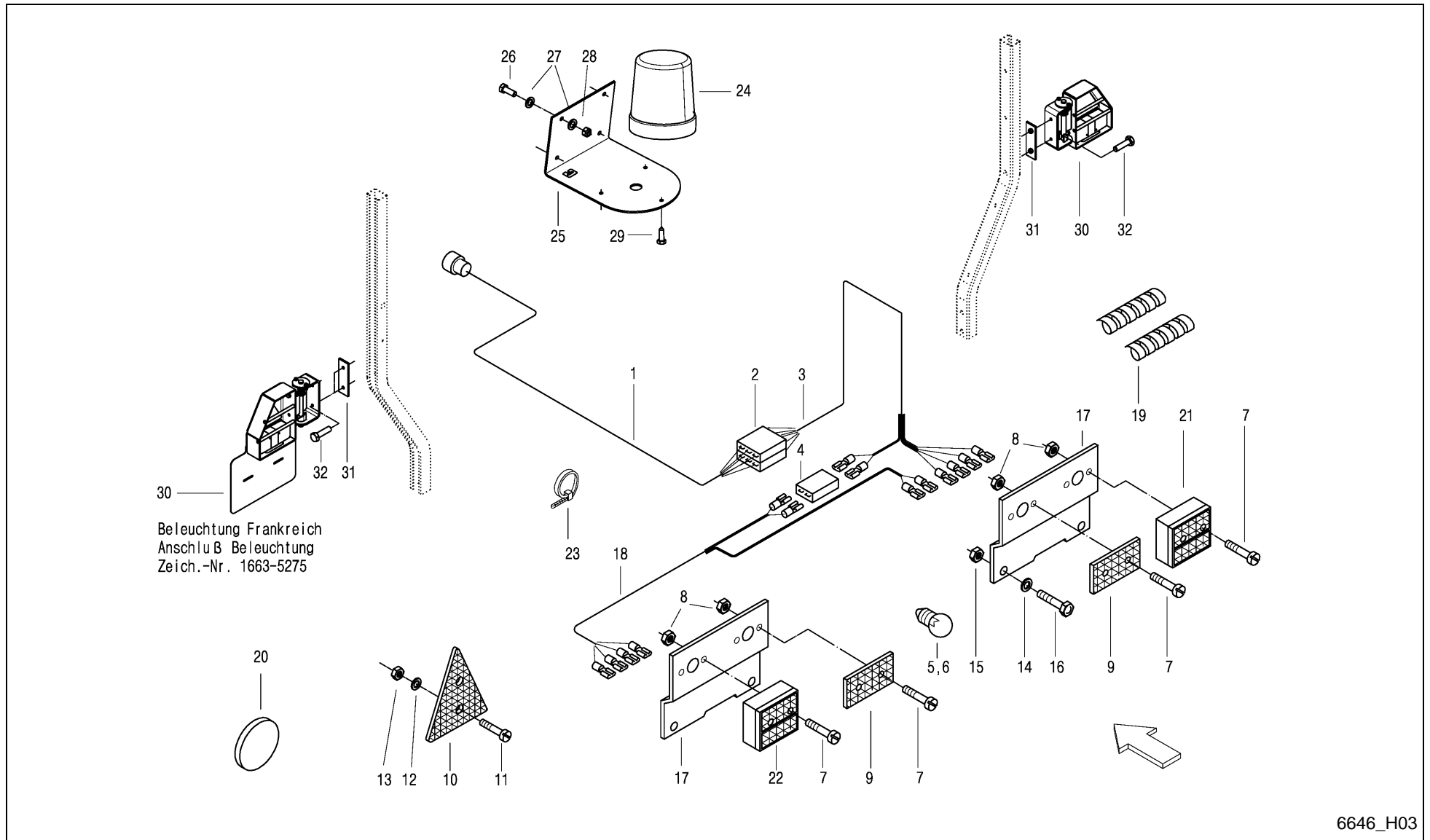

Alpex 280 / ELECTR.EQUIPMENT LIGHTING



PosNo.	Part No.	Qty.	Description	Remark
1	VF16631872	1	CABLE L=10400	
2	VF06213977	1	CABLE CONNECTOR	
3	VF16516330	1	ELECTRIC LINES	
4	VF06213973	1	CONNECTING PIECE	
5	VF01102550	2	TABULAR LAMP12V 21W D72601	
6	VF01135950	2	BULB	
7	VF01105524	8	CHEESE HEAD SCREW	
8	VF06209765	8	LOCK NUT M5 8 GALV. DIN985	
9	VF04308511	2	REAR REFLECTOR	außer Frankreich
10	VF16631249	2	TRIANGLE REAR REFLECTOR	
11	VF01105526	4	CYL. SCREW AM 5X16 DIN 84 - A3C -4.8	
12	VF01102796	4	SPRING WASHER	
13	VF01112803	4	HEX. NUT M5	
14	VF01107095	4	WASHER 6,4DIN125 GALV.	
15	VF01114357	4	LOCK NUT	
16	VF01103316	4	HEX. HEAD SCREW	
17	VF16515977	2	LIGHT RETAINER	
18	VF16516333	1	ELECTRIC LINES	
19	VF06558568	4	WIRE CHAFING GUARD	
20	VF06214041	2	REFLECTOR WHITE D80 WITH HOLE 5.5	Schweiz
21	VF01397870	1	TAIL LIGHT	
22	VF01397871	1	TAIL LIGHT	
23	VF06216479	35	CABLE TIE 150X3,6 SW SNX 2-35	
24	VF16635245	1	BEACON	Option Rundumkennleuchte
25	VF16635247	1	ANGLE PLATE,	Option Rundumkennleuchte
26	VF01112264	4	HEX. HEAD SCREW	Option Rundumkennleuchte
27	VF06214189	8	WASHER 6,4X18X2 A2C	Option Rundumkennleuchte
28	VF01114357	4	LOCK NUT	Option Rundumkennleuchte
29	VF16635249	3	SCREW 4.8X16	Option Rundumkennleuchte
30	A132715530	1	85X FRENCH LIGHTNING KIT (GREY)	Sonderbausatz Beleuchtung Frankreich
31	A143045286	2	COUNTER PLATE, WELDED	
32	VF01112341	4	HEX. HEAD SCREW	

Alpex 280 / ELECTR.EQUIPMENT LIGHTING



PosNo.	Part No.	Qty.	Description	Remark
1	VF16512287	2	MAGNET	
2	VF16514460	2	SWITCH	
3	VF16517215	2	SWITCH HOUSING	
4	VF01111071	4	HEX. HEAD SCREW	
5	VF01107095	4	WASHER 6,4DIN125 GALV.	
6	VF16516335	1	ELECTRIC LINES	
7	VF06216396	4	HOSE CLIP	
8	VF01397855	4	CONNECTOR/UNION	
9	VF16516337	1	ELECTRIC LINES	
10	VF06213974	2	PLUG CONNECTION	
11	VF16515739	1	ELECTRIC LINES	
12	VF06216479	6	CABLE TIE 150X3,6 SW SNX 2-35	
13	VF06216480	2	CABLE TIE 368X4,8 SW SNX 3-100	
14	VF01132294	2	SCR. M5X25 D963 48 GALV.	
15	VF06209765	2	LOCK NUT M5 8 GALV. DIN985	
16	VF01107158	2	WASHER	
17	VF01114357	4	LOCK NUT	
18	VF01169436	1	CABLE-CONNECTOR	
19	VF16611318	1	BASE PLATE	
20	VF16611317	1	BASE PLATE	
21	VF16613283	6	CABLE RETAINER	

Alpex 280 / PICK-UP 1.6 SCRAPER

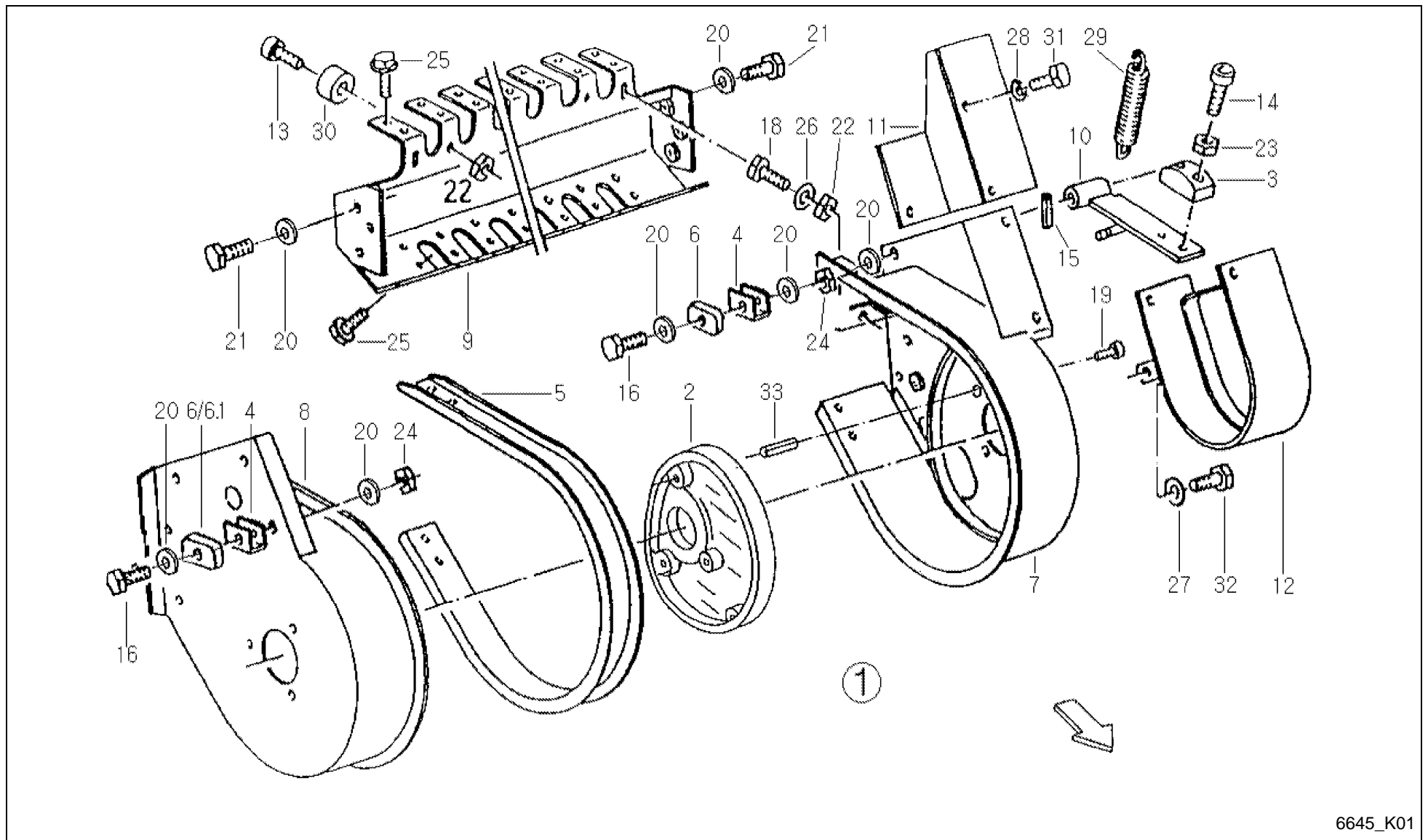

6645_K01

Alpex 280 / PICK-UP 1.6 SCRAPER



PosNo.	Part No.	Qty.	Description	Remark
1	VF16630125	1	PICK-UP 5 REEL	
2	VF06296264	1	STEERING PLATE	
3	VF06571134	1	TENSION-BLOCK	
4	VF06571322	3	YOKE	
5	VF16630114	25	SCRAPER	
6	VF06571323	6	STOP	
6.1	VF16635132	1	LIMIT STOP	+A 2012 Serie
7	VF16630115	1	SIDE PLATE LEFT	
8	VF16630119	1	SIDE PLATE RIGHT	
9	VF16630112	1	SUPPORT	
10	VF06559221	1	TENSIONER	
11	VF06571099	1	GUARD PLATE	
12	VF06571090	1	CHAIN/TRACK GUARD	
13	VF01105544	2	CYLINDRICAL SCREW	
14	VF01110577	2	SCREW	
15	VF01115441	1	DOWEL PIN	
16	VF01111288	3	HEX. HEAD SCREW	
18	VF01112264	2	HEX. HEAD SCREW	
19	VF06209476	2	BOLT M8X30 D933 8.8 A3C DIN267-27 COATE	
21	VF01112418	6	BOLT, SCREW	
22	VF01114357	4	LOCK NUT	
23	VF01104944	2	NY LOCK NUT 8A3CD985	
24	VF06209768	9	LOCK NUT	
25	VF06273854	106	HEX. HEAD SCREW	
25.1	VF0905191000	106	GEWINDEFURCHSCHRAUBE M 6 X 16	E Pos.25 +A 2009
26	VF06214189	4	WASHER 6,4X18X2 A2C	
27	VF01107163	1	WASHER	
28	VF01102799	3	SPRING WASHER	
29	VF06215561	1	TENSION SPRING	
30	VF06571355	2	RUBBER BLOCK	
31	VF01112322	3	HEX. HEAD SCREW	
32	VF01112307	1	HEX. HEAD SCREW	
33	VF16614668	1	PIN, TENSION	

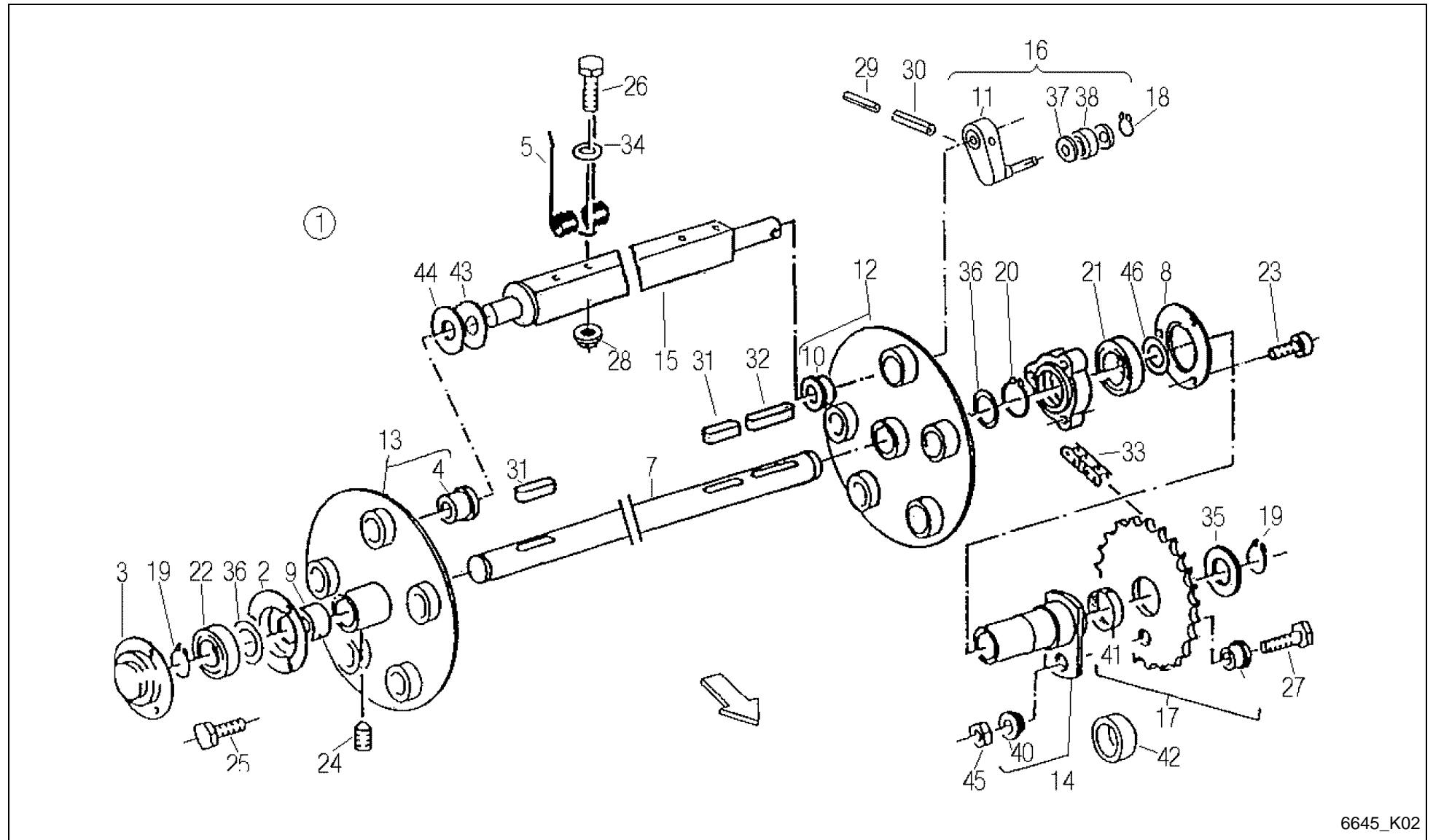

6645_K02



Alpex 280 / PICK-UP 1.6 DRUM

PosNo.	Part No.	Qty.	Description	Remark
1	VF16630125	1	PICK-UP 5 REEL	
2	VF06282196	1	TERMINAL RING	
3	VF06301830	1	TERMINAL RING	
4	VF06246795	5	BUSH	
5	VF06296285	65	PICK-UP TINE, TWIN	
6	VF06577397	1	FLANGE	
7	VF06571004	1	DRIVE SHAFT	
8	VF06577406	1	COVER	
9	VF06577407	1	SPACER RING	
10	VF06571309	5	BUSH	
11	VF06571321	5	PIN	
12	VF16513298	1	ROSETTE	
13	VF16513299	1	ROSETTE	
14	VF06559244	1	FLANGED HUB	
15	VF16613400	5	TUBE	
16	VF16615203	5	CONTROL ARM	
17	VF06577432	1	CHAIN SPROCKET	
18	VF01107726	5	CIRCLIP	
19	VF01107742	2	CIRCLIP	
20	VF01107760	1	CIRCLIP	
21	VF01108982	1	GR.BALL BEARING	
22	VF01136763	1	GR. BALL BEARING	
23	VF02953340	3	BOLT M8X50 D912 DIN267-27 COATED	
24	VF06208913	2	ALLEN SET SCREW, INT. HEX.	
25	VF01173381	3	SCR.M8X20 D933 8.8 GALV.DIN267-27MKL	
26	VF01111184	65	HEX.BOLT	
27	VF16630966	1	SHEAR SCREW	
28	VF01397863	65	WHEEL NUT M8 D6926 8 GALV.	
29	VF01157348	5	DOWEL PIN	
30	VF01157382	5	ROLL PIN 10X65 EN ISO 8752 ZN.FL.	
31	VF06212426	2	FITTING KEY	
32	VF06212435	1	FITTING KEY	
33	A143015000	1	CHAIN 12B-1VX86E INCL. VGL	
34	VF01138374	65	WASHER	
35	VF06214490	1	SPACER	
36	VF06214481		SPACER 30X42X1 DIN988	
36	VF01138686		SPACER 30X42X0,5 DIN988	
37	VF06214938	10	NILOSRING 6303 ZAV	
38	VF06215027	5	LAUFROLLE LR 203NPPU 17X47X12	
40	VF06571314	2	BUSH	

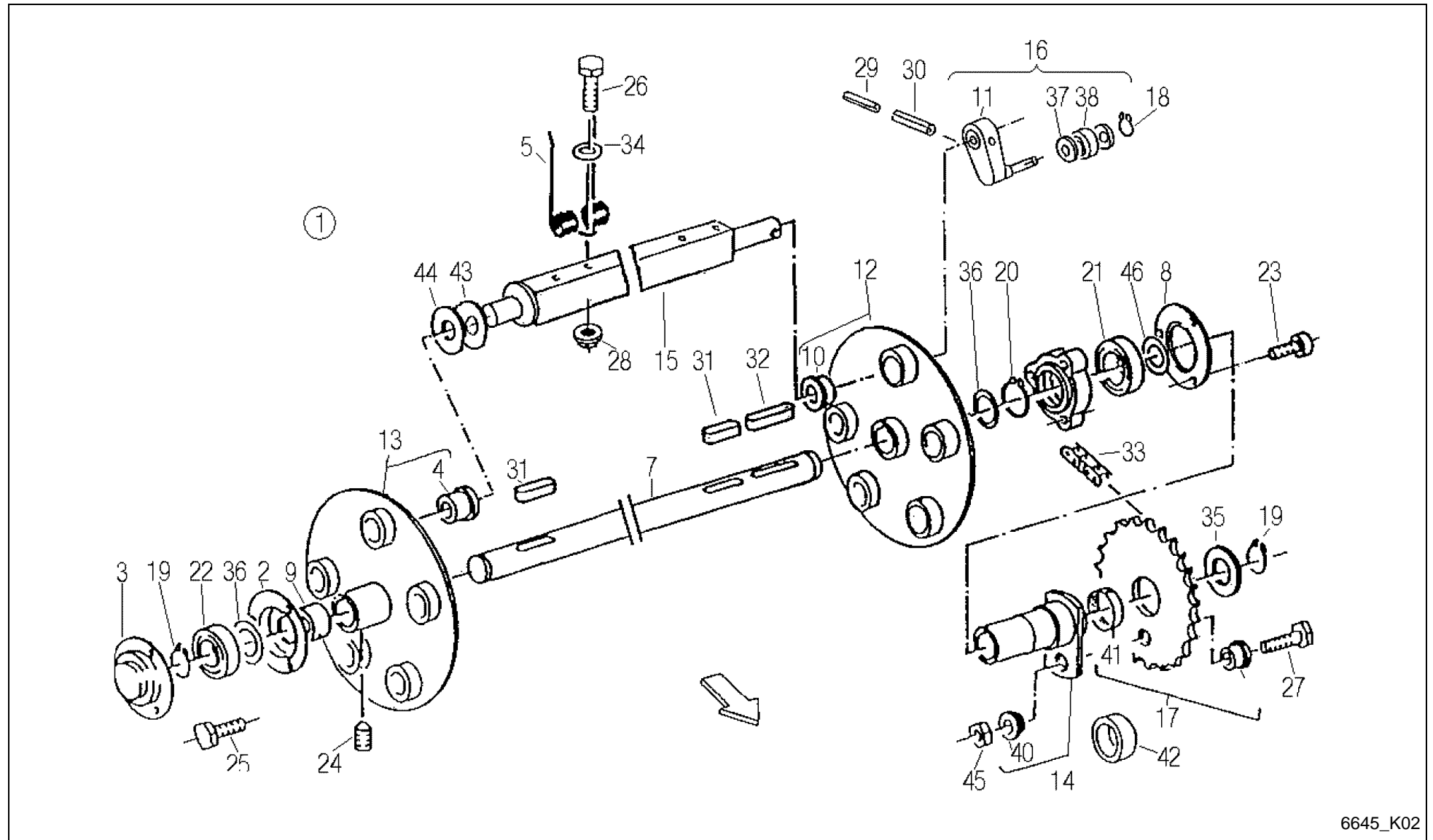

6645_K02

Alpex 280 / PICK-UP 1.6 DRUM



PosNo.	Part No.	Qty.	Description	Remark
41	VF06277516	1	BEARING BUSH	
42	VF06571148	1	PIPE/TUBE	
43	VF06214314	5	WASHER 26X38X1 GALV.	
44	VF06214313	5	WASHER 26X38X2 GALV.	
45	VF01104944	1	NY LOCK NUT 8A3CD985	
46	VF06214570		SPACER	
46	VF06214572		SPACER 45X55X0,5	

Alpex 280 / PICK-UP 1.6 BAFFLE PLATE

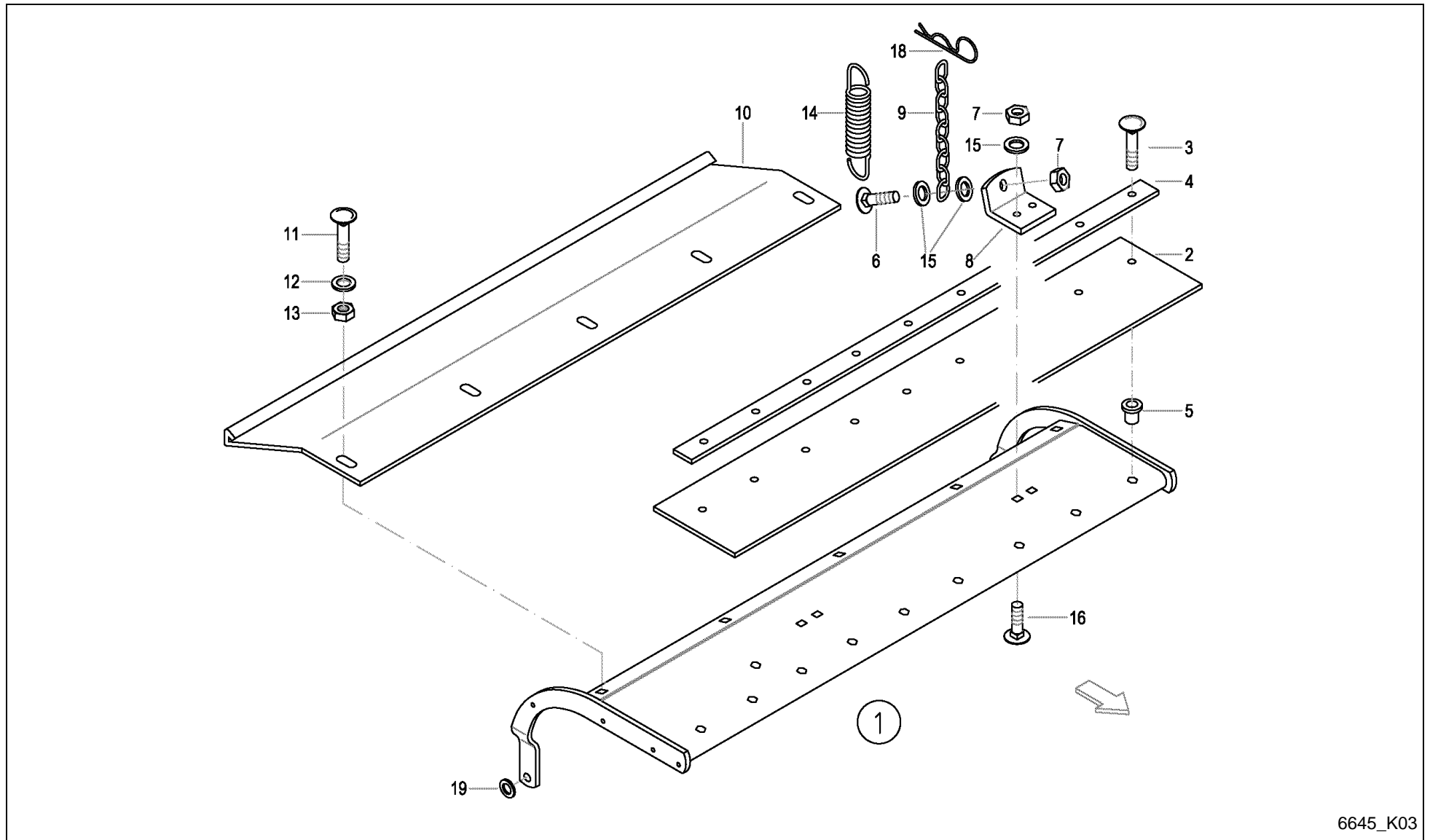

6645_K03



Alpex 280 / PICK-UP 1.6 BAFFLE PLATE

PosNo.	Part No.	Qty.	Description	Remark
1	VF16611487	1	BAFFELE-PLATE	
2	VF16611479	1	RUBBER BAR	x 1
3	VF01142806	9	TRUSS-HEAD SCREW	x1
4	VF06578934	1	STRIP	x1
5	VF01142805	9	RIVET NUT	x1
6	VF01137628	2	SAUCER HEAD SCREW	
7	VF01104944	6	NY LOCK NUT 8A3CD985	x1
8	VF16513473	2	RETAINER	x1
9	VF01397609	2	CHAIN/TRACK	
10	VF06577423	1	EXTENSION	
11	VF06207535	5	OVAL HEADED BOLT	
12	VF01107165	5	WASHER M10 11X20X2 A2C DIN126	
13	VF01104944	5	NY LOCK NUT 8A3CD985	
14	VF01397931	2	DRAW SPRING	
15	VF01127538	4	WASHER	
16	VF01108524	4	SCREW	x1
18	VF06215666	2	SPRING CLIP	

Alpex 280 / PICK-UP 1.6 TACTILE WHEEL PNEUMATIC TIRE

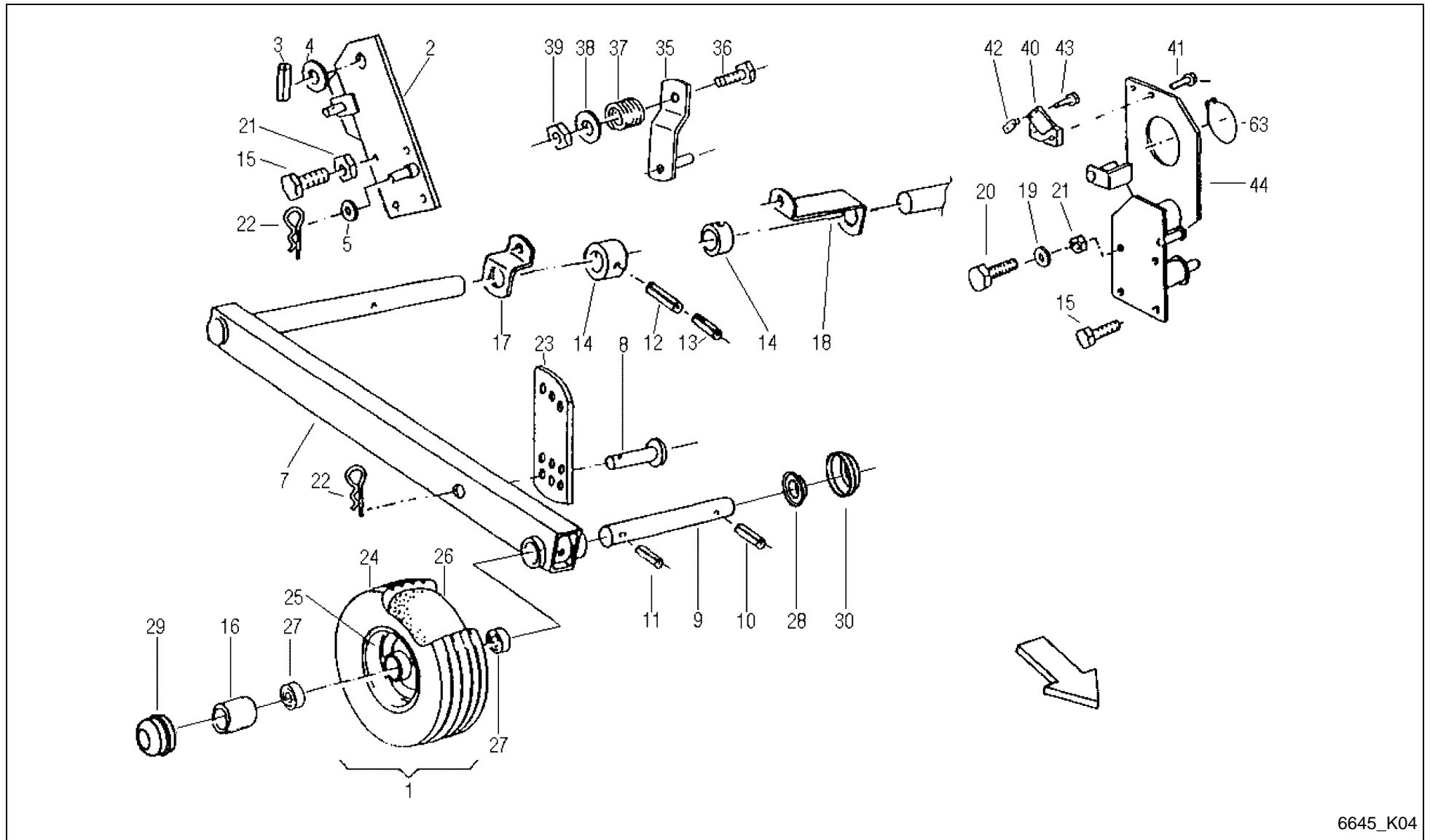

6645_K04

Alpex 280 / PICK-UP 1.6 TACTILE WHEEL PNEUMATIC TIRE



PosNo.	Part No.	Qty.	Description	Remark
1	VF06564733	2	CPL. WHEEL 15X6.0-6 TT 6PR SILVER RIM	
2	VF16630109	1	RETAINER RIGHT	
3	VF01115460	1	COLLET CHUCK	
4	VF06214234	1	WASHER 31X45X2 GALV.	
5	VF06214226	1	WASHER	
7	VF16517499	2	AXLE LINK	
8	VF06210033	2	PIN	
9	VF16514201	2	PIN/BOLT/STUD	
10	VF01115457	2	DOWEL PIN	
11	VF01157344	1	DOWEL PIN	
12	VF01123863	1	DOWEL PIN	
13	VF01157338	2	DOWEL PIN	
14	VF06577422	2	RING	
15	VF01173914	4	SCR. M10X25D933 8.8 GALV. DIN267-27	
16	VF06576830	2	PIPE	
17	VF06577421	1	SUPPORT	
18	VF06577420	1	SUPPORT	
19	VF01127538	2	WASHER	
20	VF01112429	4	HEX. HEAD SCREW	
21	VF06209768	4	LOCK NUT	
22	VF06215666	4	SPRING CLIP	
23	VF06556744	2	ARM	
24	VF01141364	2	TIRE 15X6.00-6 6PR TT C737	
25	VF06564735	2	RIM 4.50 AX6 SILVER	
26	VF01141365	2	INNER TUBE 15X6,00X6 TR13	
27	VF01124703	4	BEARING	
28	VF06567492	1	BUSH D25+31,5 L13,5	
29	VF06567493	2	WHEEL CAP D 52 H = 36 MM	
30	VF16622598	1	ANTI WRAPPING DEVICE MEFRO 15"+16" ZN	
35	VF06558198	1	LEVER	
36	VF01111298	1	HEX. HEAD SCREW	
37	VF06215308	1	COMPRESSION SPRING	
38	VF01107165	1	WASHER M10 11X20X2 A2C DIN126	
39	VF06209768	1	LOCK NUT	
40	A143018986	1	RELEASE UNIT	
41	VF06277504	2	HEX. HEAD SCREW	
42	VF06587560	1	SLIDE PIECE	
43	VF01112333	2	HEX. HEAD SCREW	
44	VF16630106	1	SUPPORT	
63	VF01107792	1	CIRCLIP	

Alpex 280 / PICK-UP 1.6 BAFFLE PLATE WITH ROLE

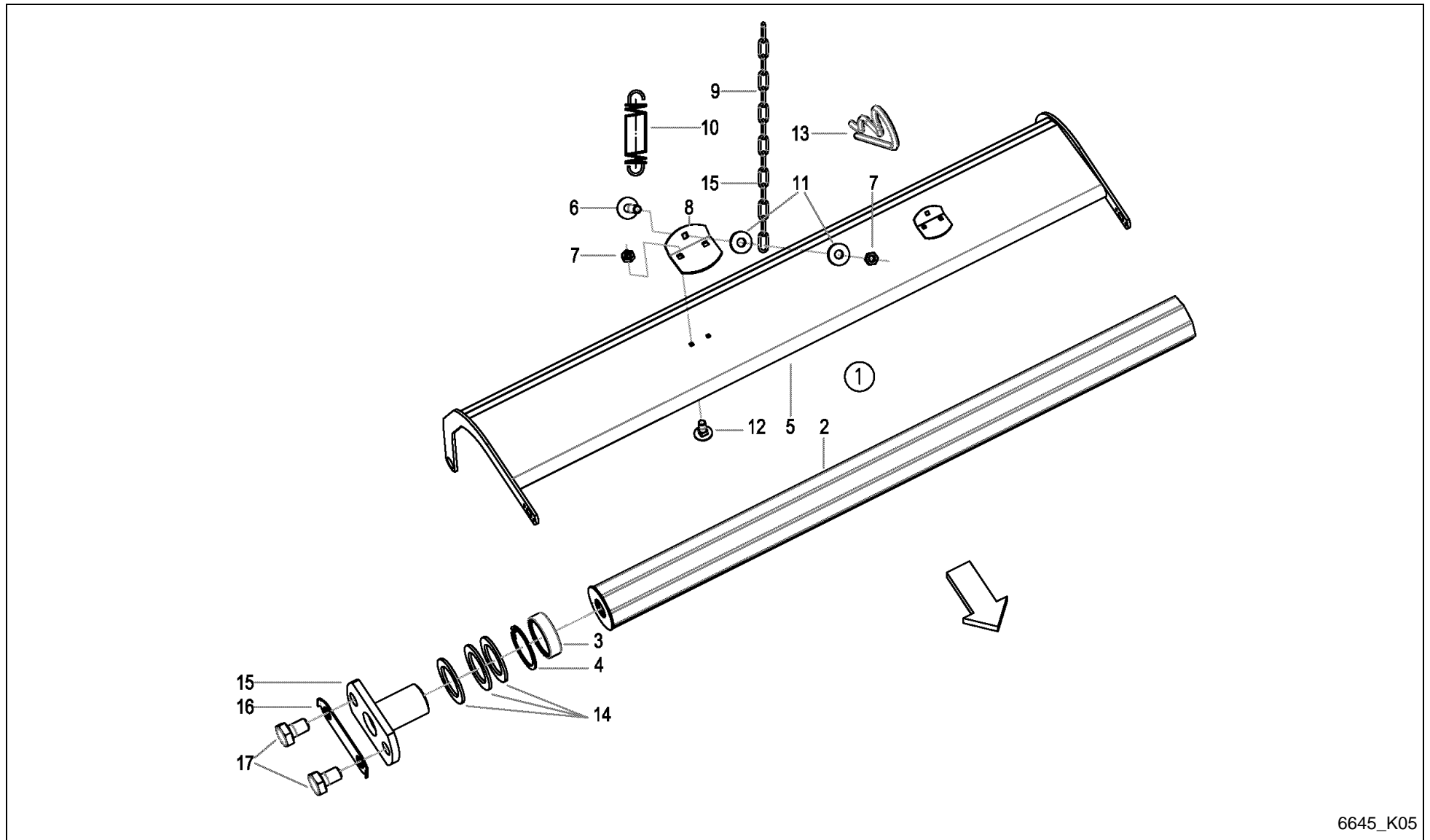

6645_K05



Alpex 280 / PICK-UP 1.6 BAFFLE PLATE WITH ROLE

PosNo.	Part No.	Qty.	Description	Remark
1	VF16631430	1	BAFFLE PLATE WITH ROLE	
2	VF16631427	1	ROLE PREASSEMBLED	inkl. Pos. 3+4
3	VF01136762	2	BEARING	
4	VF01107838	2	CIRCLIP	
5	VF16631429	1	BAFFLE PLATE	
6	VF01137628	2	SAUCER HEAD SCREW	
7	VF01104944	6	NY LOCK NUT 8A3CD985	
8	VF16513473	2	RETAINER	
9	VF01397609	2	CHAIN/TRACK	
10	VF01397931	2	DRAW SPRING	
11	VF01127538	4	WASHER	
12	VF01108524	4	SCREW	
13	VF06215666	2	SPRING CLIP	
14	VF06214313	12	WASHER 26X38X2 GALV.	
15	VF16631126	2	BOLT WELDED	
16	VF16631133	2	SAFETY PLATE	
17	VF01178250	4	HEX. HEAD SCREW	

Alpex 280 / PICK-UP 1.8 DRUM

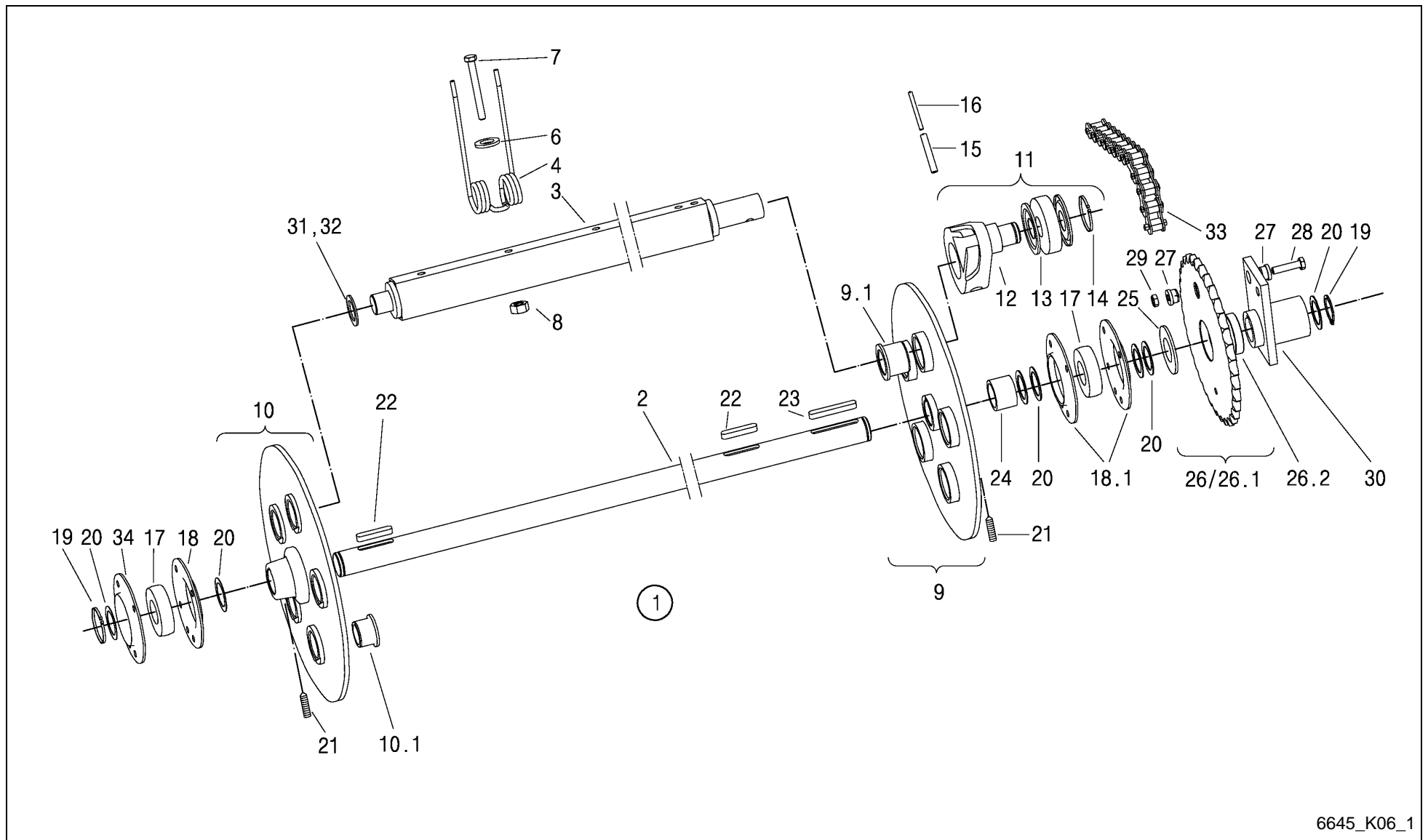

6645_K06_1



Alpex 280 / PICK-UP 1.8 DRUM

PosNo.	Part No.	Qty.	Description	Remark
1	A143030430	1	PICK-UP 1.8 ASSEMBLED	
2	VF16630685	1	DRIVE SHAFT	
3	VF16630682	5	TUBE WELDED	
4	VF06296285	70	PICK-UP TINE, TWIN	
6	VF01138374	70	WASHER	
7	VF01111184	70	HEX.BOLT	
8	VF01397863	70	WHEEL NUT M8 D6926 8 GALV.	
9	VF16513298	1	ROSETTE	
9.1	VF06571309	5	BUSH	
10	VF16513299	1	ROSETTE	
10.1	VF06246795	5	BUSH	
11	VF16615203	5	CONTROL ARM	
12	VF16618715	5	LEVER	
13	VF06215027	5	LAUFROLLE LR 203NPPU 17X47X12	
14	VF01107726	5	CIRCLIP	
15	VF01157382	5	ROLL PIN 10X65 EN ISO 8752 ZN.FL.	
16	VF01157348	5	DOWEL PIN	
17	VF16630709	2	FLANGED SLEEVE 1726206 2RS	
18	VF16630686	0.5000	SHEET METAL CASE 2-PIECE	
18.1	VF16631187	1	BEARING FLANGE 2-PIECE	2x VF16630769
19	VF01107742	2	CIRCLIP	
20	VF06214481	20	SPACER 30X42X1 DIN988	
21	VF06208913	2	ALLEN SET SCREW, INT. HEX.	
22	VF06212426	2	FITTING KEY	
23	VF16630743	1	FITTING KEY A8X7X60	
24	VF16630766	1	SPACER RING	
25	VF06214420	1	DISC	
26	VF16630156	1	CHAIN SPROCKET Z=34	-A 2005 für 6R
26.1	VF06577432	1	CHAIN SPROCKET	für 4R; +A 2006 auch für 6R
26.2	VF06277516	1	BEARING BUSH	
27	VF06571314	2	BUSH	
28	VF16630966	1	SHEAR SCREW	
29	VF01104944	1	NY LOCK NUT 8A3CD985	
30	VF16630744	1	FLANGED HUB	
31	VF06214314	5	WASHER 26X38X1 GALV.	
32	VF06214313	5	WASHER 26X38X2 GALV.	
33	VF16630768.01	1	CHAIN 12B-1VX90E	-A 2005 für 6R
33	VF16630767.01	1	CHAIN 12B-1VX89L	+A 2006
34	VF16631868	1	COVER	

Alpex 280 / PICK-UP 1.8 SCRAPER

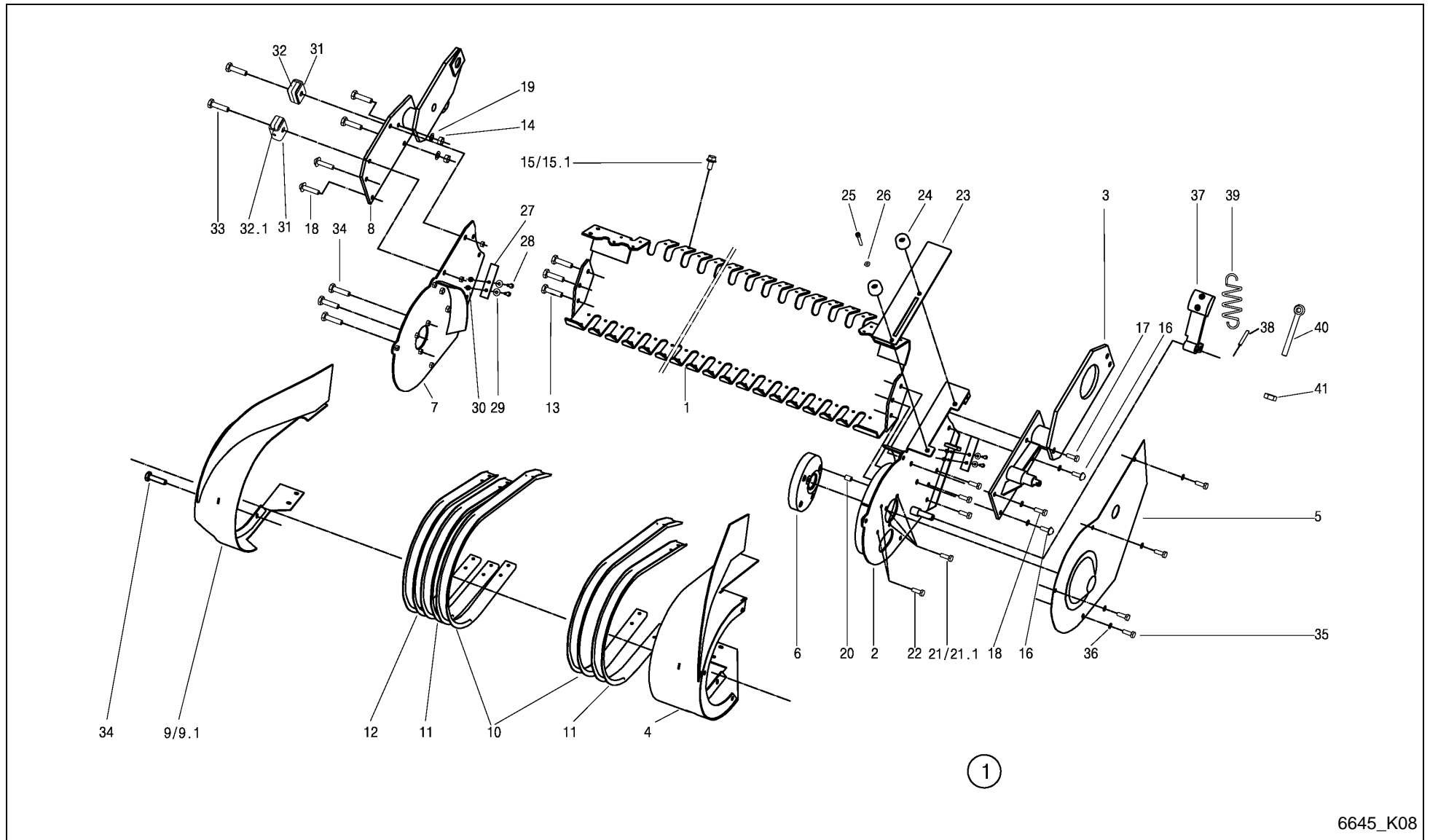

6645_K08



Alpex 280 / PICK-UP 1.8 SCRAPER

PosNo.	Part No.	Qty.	Description	Remark
1	VF16630705	1	SUPPORT	
2	VF16630695	1	SIDE MEMBER LEFT	
3	VF16630690	1	SUPPORT LEFT	
4	VF16630716	1	COVERING LEFT WELDED	
5	VF16630738	1	GUARD PLATE	
6	VF06296264	1	STEERING PLATE	
7	VF16630700	1	SIDE MEMBER RIGHT	
8	VF16630710	1	SUPPORT RIGHT WELDED	
9	VF16630736	1	COVERING	
9.1	VF16630736.01	1	COVERING PU 1,8	+A 2004
10	VF16630706	24	SHEET	
11	VF16630707	2	SHEET OUTSIDE	
12	VF16630746	1	SHEET SHORT	
13	VF01112418	6	BOLT, SCREW	
14	VF06209768	4	LOCK NUT	
15	VF06273854	114	HEX. HEAD SCREW	
15.1	VF0905191000	114	GEWINDEFURCHSCHRAUBE M 6 X 16	E Pos.15 +A 2009 Serie
16	VF01142213	22	TRUSS-HEAD SCREW	
17	VF01112429	3	HEX. HEAD SCREW	
18	VF01173914	3	SCR. M10X25D933 8.8 GALV. DIN267-27	
19	VF01127538	4	WASHER	
20	VF16614668	3	PIN, TENSION	
21	VF01111136	3	VIS	
21.1	VF16631186	3	BOLT M8X45 D933 8.8	+A 2004 mit Pos 18.1/K06
22	VF06209476	2	BOLT M8X30 D933 8.8 A3C DIN267-27 COATE	
23	VF16630721	1	CRANK PU 1,8	
24	VF01141112	2	RUBBER PAD	
25	VF16630742	2	SCREW M8X35 DIN912 8.8	
26	VF01107163	2	WASHER	
27	VF16630734	2	RUBBER SHEET	
28	VF01112264	4	HEX. HEAD SCREW	
29	VF06214189	4	WASHER 6,4X18X2 A2C	
30	VF01114357	4	LOCK NUT	
31	VF06571322	2	YOKE	
32	VF06571323	4	STOP	
32.1	VF16635132	1	LIMIT STOP	+A 2012 Serie
33	VF01112451	2	HEX. HEAD SCREW	
34	VF01173381	9	SCR.M8X20 D933 8.8 GALV.DIN267-27MKL	
35	VF01112307	4	HEX. HEAD SCREW	
36	VF16631181	4	WASHER A8	

Alpex 280 / PICK-UP 1.8 SCRAPER

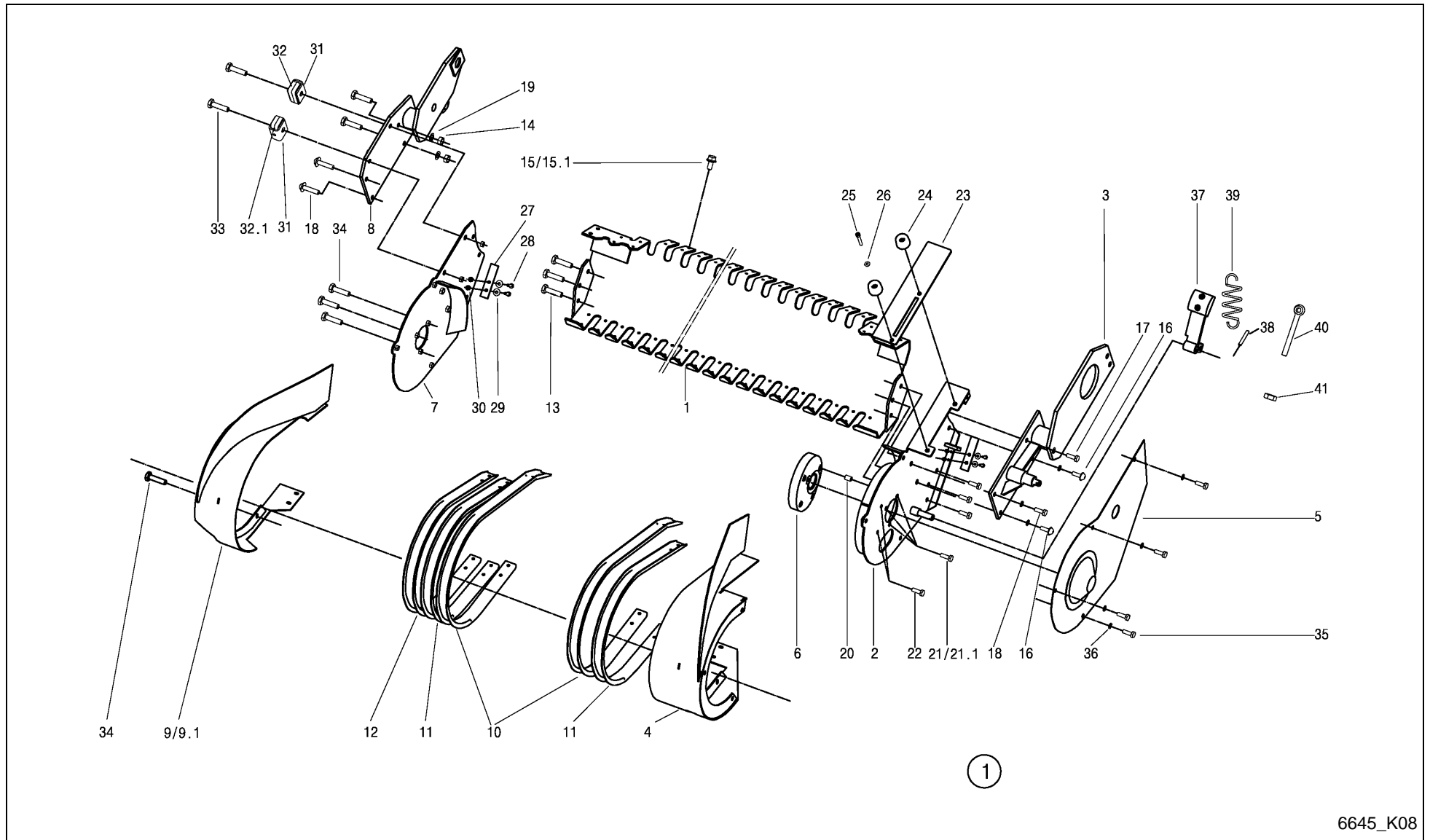

6645_K08

Alpex 280 / PICK-UP 1.8 SCRAPER



PosNo.	Part No.	Qty.	Description	Remark
37	VF16630745	1	TENSIONER	
38	VF01115441	1	DOWEL PIN	
39	VF06215561	1	TENSION SPRING	
40	VF01138951	1	EYE BOLT LBM 8X 50 DIN 444 - 4.6	
41	VF01112824	2	HEX. NUT	

Alpex 280 / PICK-UP 1.8 TACTILE WHEEL PNEUMATIC TIRE



PosNo.	Part No.	Qty.	Description	Remark
1	VF06564733	2	CPL. WHEEL 15X6.0-6 TT 6PR SILVER RIM	
7	VF16517499	2	AXLE LINK	
8	VF06210033	2	PIN	
9	VF16514201	2	PIN/BOLT/STUD	
10	VF01115457	2	DOWEL PIN	
11	VF01157344	2	DOWEL PIN	
12	VF01123863	2	DOWEL PIN	
13	VF01157338	2	DOWEL PIN	
14	VF06577422	2	RING	
15	VF01173914	4	SCR. M10X25D933 8.8 GALV. DIN267-27	
16	VF06576830	2	PIPE	
17	VF06577421	1	SUPPORT	
18	VF06577420	1	SUPPORT	
19	VF01127538	2	WASHER	
20	VF01112429	4	HEX. HEAD SCREW	
21	VF06209768	4	LOCK NUT	
22	VF06215666	4	SPRING CLIP	
23	VF06556744	2	ARM	
24	VF01141364	2	TIRE 15X6.00-6 6PR TT C737	
25	VF06564735	2	RIM 4.50 AX6 SILVER	
26	VF01141365	2	INNER TUBE 15X6,00X6 TR13	
27	VF01124703	4	BEARING	
28	VF01167577	4	ND 6198	
29	VF06580546	2	CAP	
30	VF06567492	2	BUSH D25+31,5 L13,5	
35	VF06558198	1	LEVER	
36	VF01111315	1	HEX.HEAD SCREW	
37	VF06215308	1	COMPRESSION SPRING	
38	VF01107165	1	WASHER M10 11X20X2 A2C DIN126	
39	VF06209768	1	LOCK NUT	
40	VF06577387	1	GRAPHITE RING	
41	VF06277504	2	HEX. HEAD SCREW	
42	VF06587560	1	SLIDE PIECE	
43	VF01112333	2	HEX. HEAD SCREW	
45	KG01273861	1	WASHER DIN7349 M14 A3C	
63	VF01107792	1	CIRCLIP	

Alpex 280 / PICK-UP 1.8 BAFFLE PLATE WITH ROLE

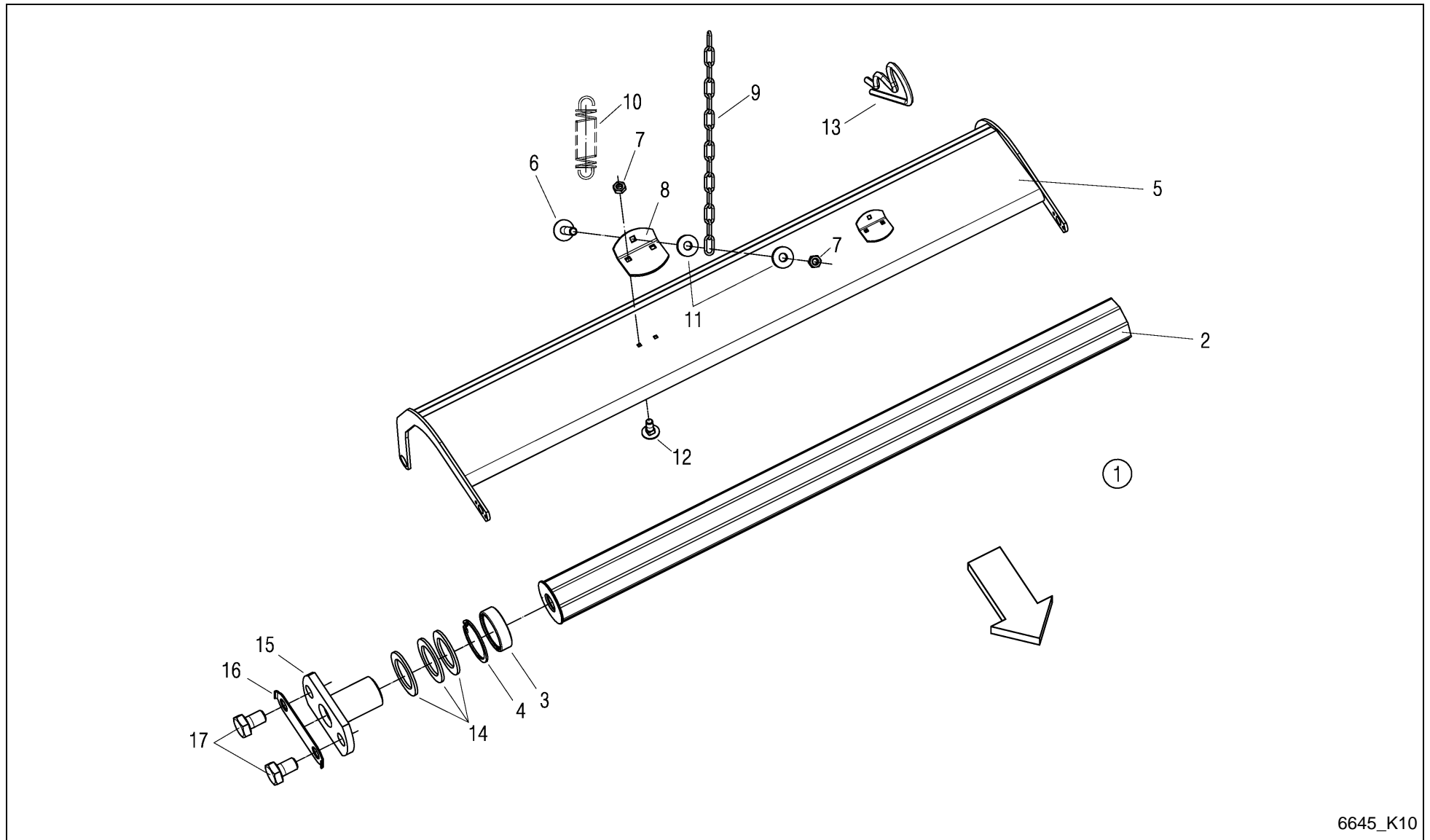

6645_K10



Alpex 280 / PICK-UP 1.8 BAFFLE PLATE WITH ROLE

PosNo.	Part No.	Qty.	Description	Remark
1	VF16631135	1	BAFFLE PLATE WITH ROLE	
2	VF16631134	1	ROLE PREASSEMBLED	inkl. Pos.3+4
3	VF01136762	2	BEARING	
4	VF01107838	2	CIRCLIP	
5	VF16631129	1	BAFFLE PLATE WELDED	
6	VF01137628	2	SAUCER HEAD SCREW	
7	VF01104944	6	NY LOCK NUT 8A3CD985	
8	VF16513473	2	RETAINER	
9	VF01397609	2	CHAIN/TRACK	
10	VF01397931	2	DRAW SPRING	
11	VF01127538	4	WASHER	
12	VF01108524	4	SCREW	
13	VF06215666	2	SPRING CLIP	
14	VF06214313	12	WASHER 26X38X2 GALV.	
15	VF16631126	2	BOLT WELDED	
16	VF16631133	2	SAFETY PLATE	
17	VF01178250	4	HEX. HEAD SCREW	

Alpex 280 / SCRAPER FLOOR BOARDS

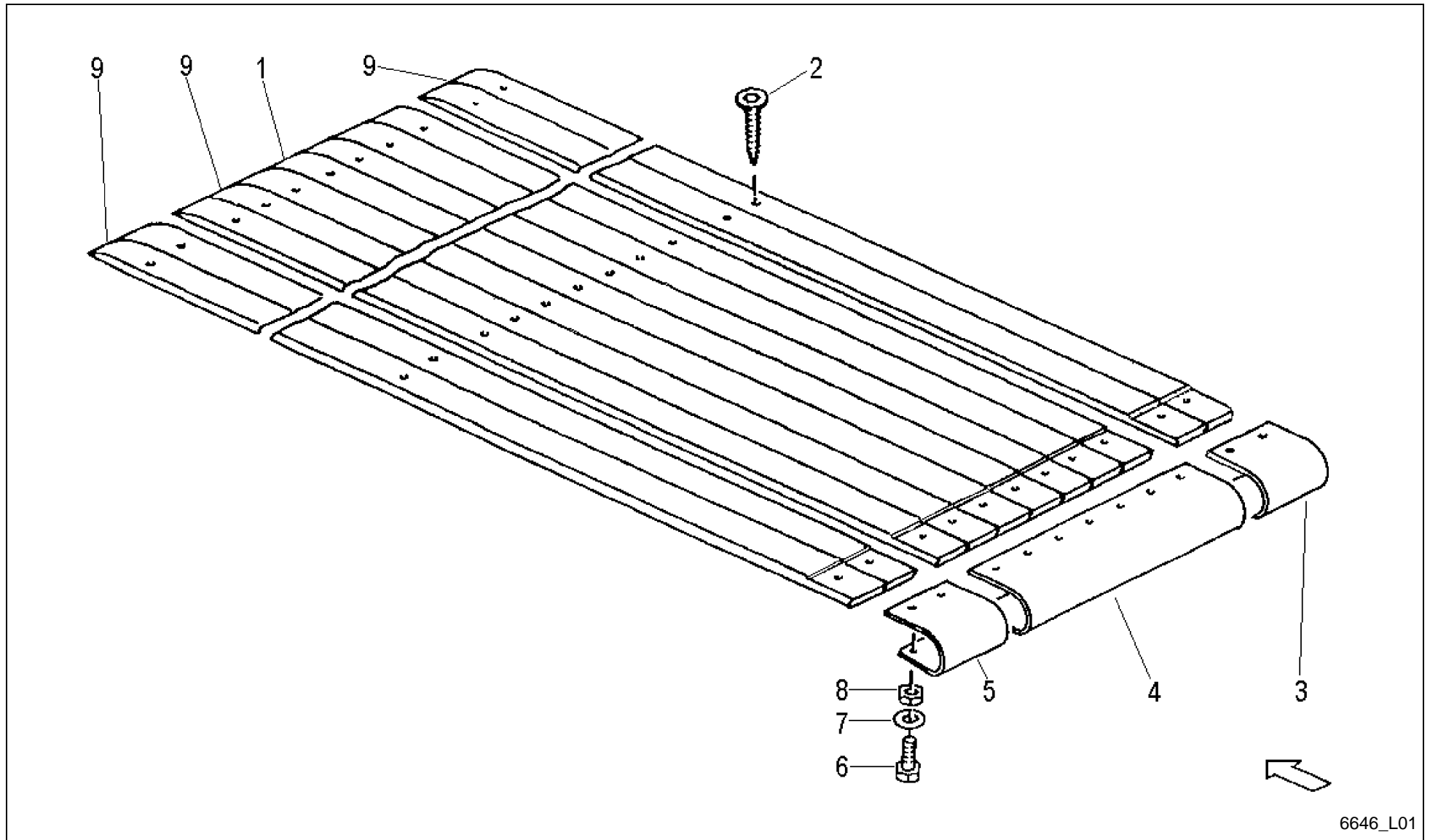

6646_L01



Alpex 280 / SCRAPER FLOOR BOARDS

PosNo.	Part No.	Qty.	Description	Remark
1	VF16631756	6	FLOORBOARD DF	
2	VF01142958	51	SELF-DRILLING SCREW 8X65 SCT 10/35 ZN	
3	VF16631599	1	METAL COVER FLOOR	
4	VF16515748	1	COVER PLATE	
5	VF16631598	1	METAL COVER FLOOR	
6	VF01173381	5	SCR.M8X20 D933 8.8 GALV.DIN267-27MKL	
7	VF06214193	5	WASHER 8,4X21X3 GALV.	
8	VF01104944	5	NY LOCK NUT 8A3CD985	
9	VF16631757	3	WOOD FOR FLOOR TL 28	

Alpex 280 / SCRAPER FLOOR

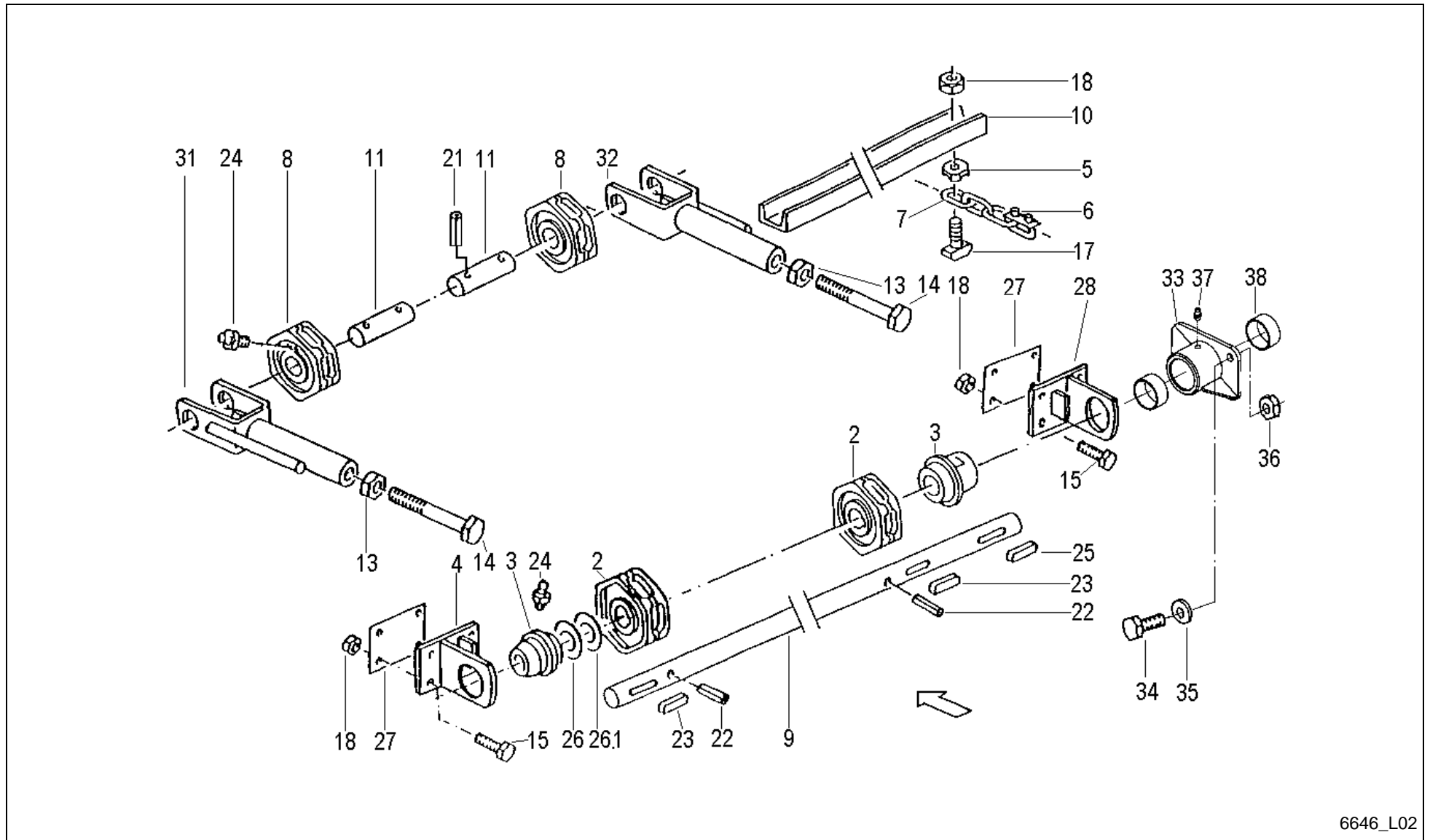

6646_L02

Alpex 280 / SCRAPER FLOOR



PosNo.	Part No.	Qty.	Description	Remark
2	VF06577063	2	CHAIN SPROCKET	
3	VF06577064	2	FLANGED SLEEVE	
4	VF06578750	1	SUPPORT PLATE	
5	VF06587268	28	DRIVE FLANGE	
6	VF06587269	2	CHAIN LOCK	
7	VF16631753	2	CHAIN A8X31 289GL.	
8	VF06577220	2	CHAIN WHEEL	
9	VF16631613	1	AXLE	
10	VF16631594	14	RAIL	
11	VF06577030	2	SHAFT	
13	VF01112916	2	HEX. NUT	
14	VF06209411	2	HEX.BOLT	
15	VF01112429	8	HEX. HEAD SCREW	
17	VF01138917	28	HAMMER BOLT	
18	VF06209768	36	LOCK NUT	
21	VF01157337	4	DOWEL PIN	
22	VF01115478	2	DOWEL PIN	
23	VF01118100	2	FITTING KEY	
24	VF01120692	4	GREASE NIPPLE H1 AM 6X1 DIN 71412	
25	VF06277510	1	SUNK KEY	
26	VF06214332	4	WASHER	
26.1	VF06214333	1	WASHER	
27	VF06577968	6	SHIM	
28	VF06550287	1	SUPPORT PLATE	
31	VF16611400	1	TENSION FORK	
32	VF16611401	1	TENSION FORK	
33	A143009986	1	BEARING TUBE, WELDED	
34	VF01112429	2	HEX. HEAD SCREW	
35	VF01107165	2	WASHER M10 11X20X2 A2C DIN126	
36	VF06209768	2	LOCK NUT	
37	VF01120693	1	GREASE FITTING H1 AM 8X1 DIN 71412	
38	VF06251677	2	SELF- LUBRICATING BUSH	

Alpex 280 / DRUM ELEVATOR GRATE

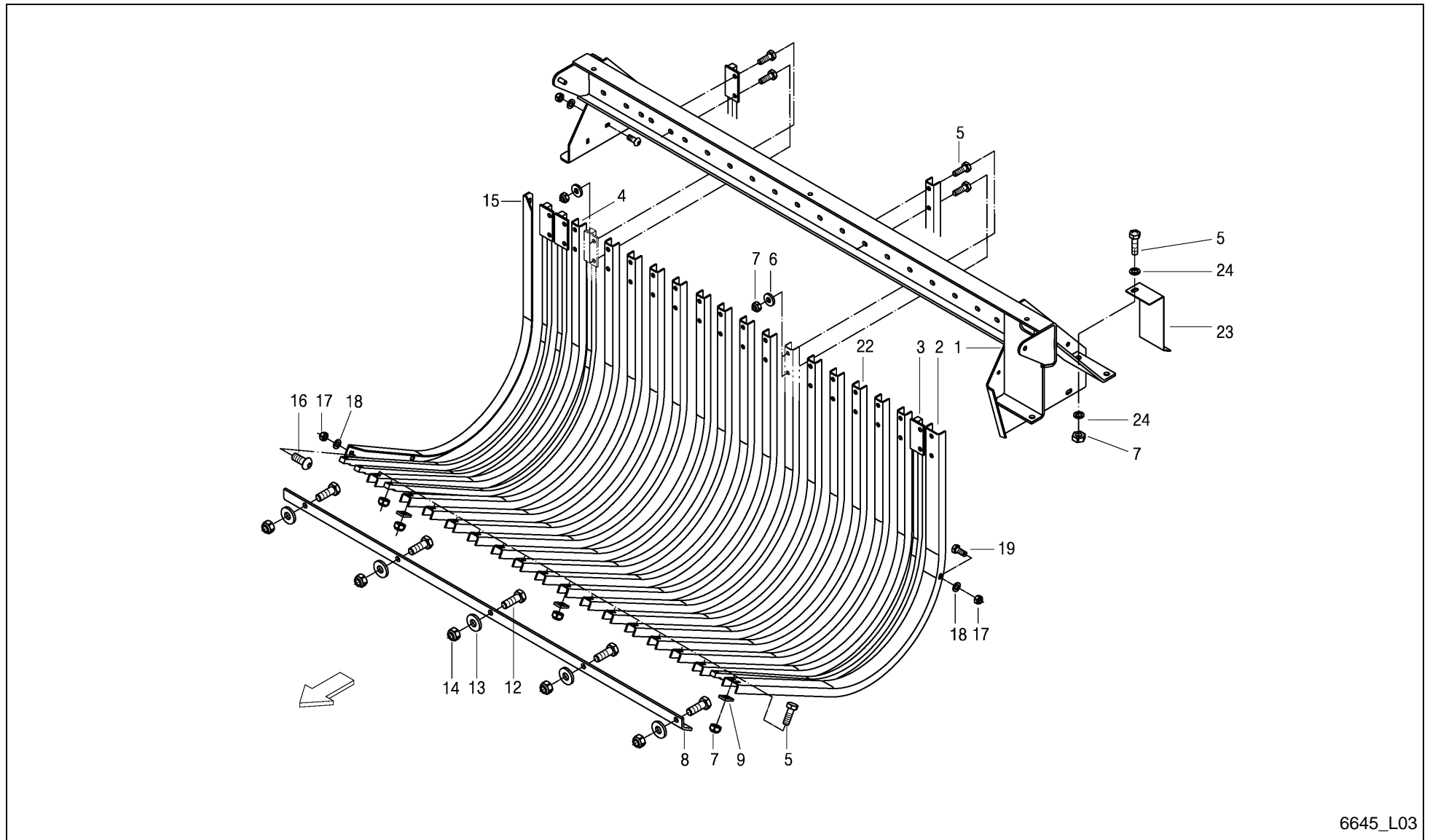

6645_L03



Alpex 280 / DRUM ELEVATOR GRATE

PosNo.	Part No.	Qty.	Description	Remark
1	VF16631530	1	SUPPORT	
2	VF16631539	1	GUIDE RAIL OUTSIDE	
3	VF16631535	4	BEND	
4	VF16631534	1	GUIDE RAIL	
5	VF01112429	61	HEX. HEAD SCREW	
6	VF01127538	40	WASHER	
7	VF06209768	61	LOCK NUT	
8	VF16611247	1	GUIDA RAIL	
9	VF06552906	32	CLIP	
12	VF01112538	5	HEX.HEAD SCREW	
13	VF06214206	5	WASHER 13X30X4 RM=580-680 MPA A2C	
14	VF06209769	5	LOCK NUT	
15	VF16631533	1	ANGLE	
16	VF01142565	6	TRUSS-HEAD SCR. M8X20 109 GALV.	
17	VF01104944	7	NY LOCK NUT 8A3CD985	
18	VF01107163	7	WASHER	
19	VF01112322	1	HEX. HEAD SCREW	
22	VF16631538	1	GUIDE RAIL	
23	VF16631659	1	ANGLED PLATE	
24	VF01107165	2	WASHER M10 11X20X2 A2C DIN126	

Alpex 280 / DRUM ELEVATOR SIDE PANELS

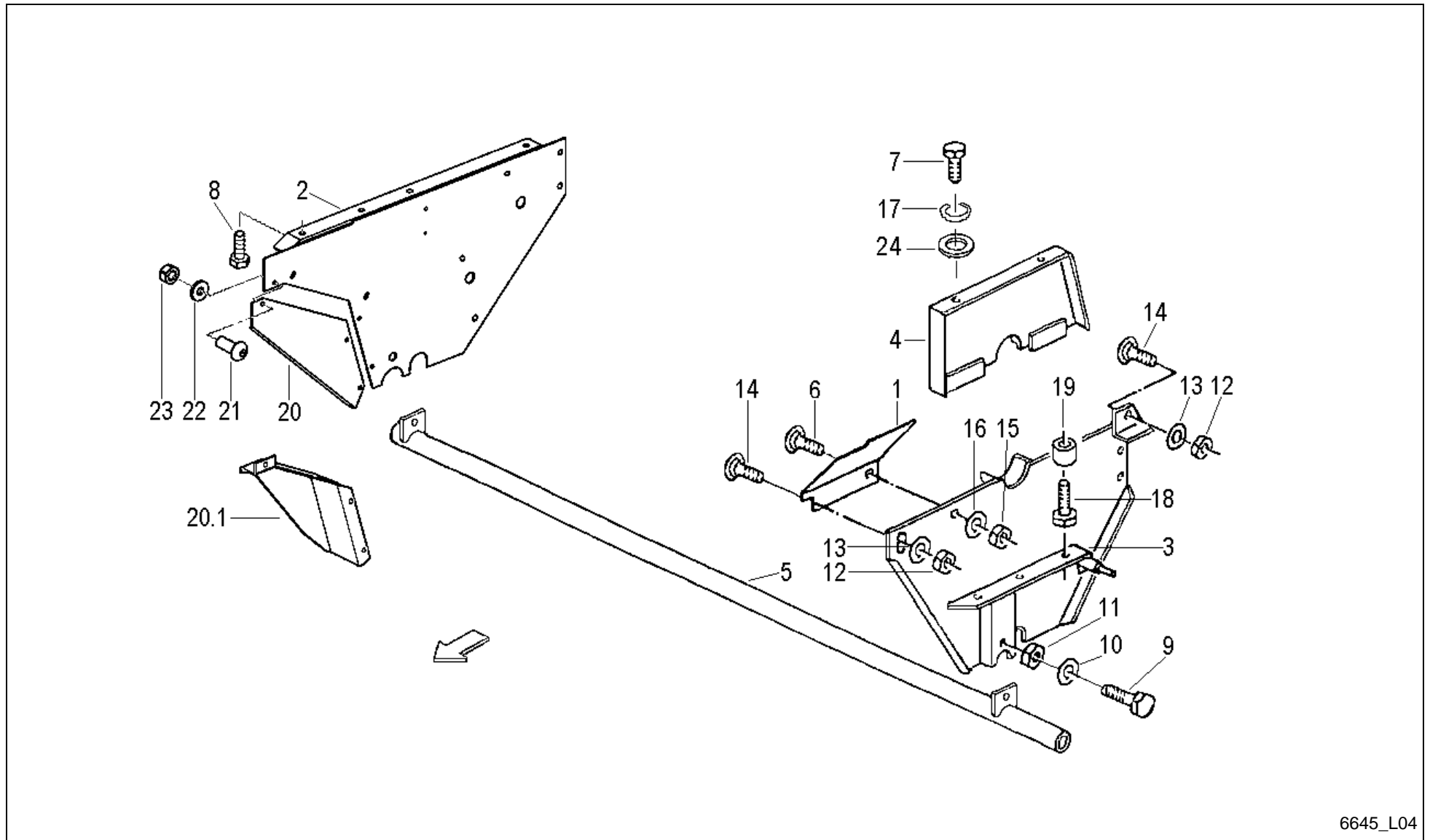

6645_L04



Alpex 280 / DRUM ELEVATOR SIDE PANELS

PosNo.	Part No.	Qty.	Description	Remark
1	VF06558937	1	SHEET	
2	VF16631220	1	SIDE PANEL RIGHT WELDED	
3	VF06571196	1	SIDE MEMBER L	
4	VF06577389	1	COVERING SHEET	
5	VF06577391	1	CROSS TUBE	
6	VF01138989	1	TRUSS-HEAD SCREW	
7	VF01112407	2	HEX. HEAD SCREW	
8	VF06209459	4	SCREW M12X35D933 8.8 A3C DIN267-27 COATE	
9	VF01177888	2	HEX.BOLT	
10	VF01169697	2	RETAINING WASHER	
11	VF01112886	2	HEX. NUT	
12	VF06209768	2	LOCK NUT	
13	VF01107165	2	WASHER M10 11X20X2 A2C DIN126	
14	VF06207557	2	SAUCER HEAD SCREW	
15	VF01114357	1	LOCK NUT	
16	VF06214189	1	WASHER 6,4X18X2 A2C	
17	VF01102800	2	SPRING WASHER	
18	VF06209245	3	SCR. M12X50D931 10.9 GALV. DIN267-27	
19	VF06571325	3	SPACER RING	
20	A143047286	1	SIDE PLATE	für Pu 1.6
20.1	VF16631184	1	REFUSE PLATE	für Pu 1.8
21	VF01142565	3	TRUSS-HEAD SCR. M8X20 109 GALV.	
22	VF06214193	3	WASHER 8,4X21X3 GALV.	
23	VF01104944	3	NY LOCK NUT 8A3CD985	
24	VF06214198	2	WASHER	

Alpex 280 / DRUM ELEVATOR DRUM 4- RAKE

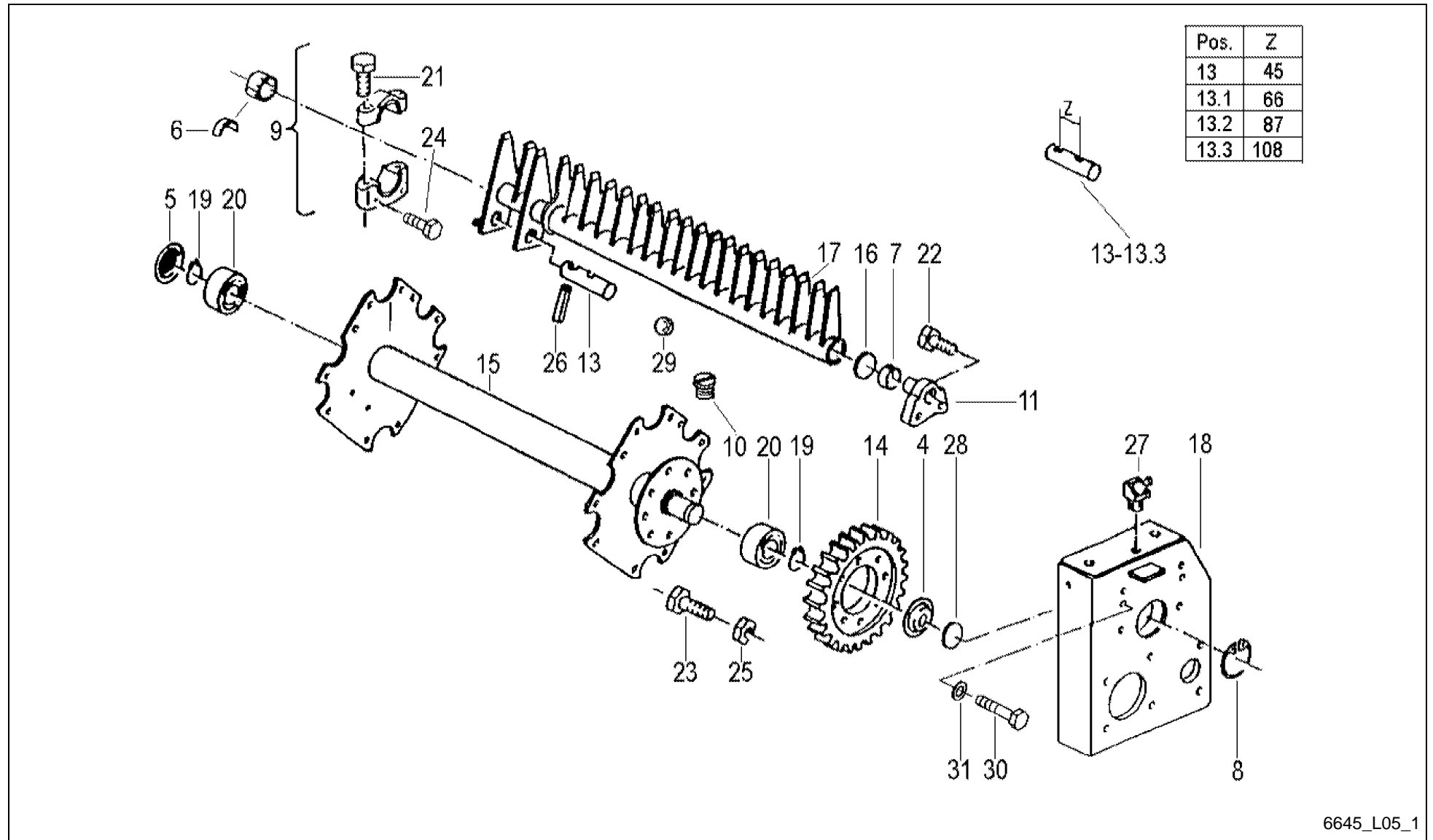



Alpex 280 / DRUM ELEVATOR DRUM 4- RAKE

PosNo.	Part No.	Qty.	Description	Remark
4	VF16516663	1	COVER	
5	VF06577317	1	CAP	
6	VF16515167	16	BEARING BRASS	
7	VF01142086	4	BUSH	
8	VF01107858	1	CIRCLIP	
9	VF16515168	4	BEARING/SUPPORT	
10	VF06216527	1	PROTECTING PLUG	
11	VF06571150	4	FLANGED PIN	
13	VF16516766	1	PIN/BOLT/STUD Z=45	
13.1	VF16516767	1	PIN/BOLT/STUD Z=66	
13.2	VF16516768	1	PIN/BOLT/STUD Z=87	
13.3	VF16516769	1	PIN/BOLT/STUD Z=108	
14	VF06577335	1	SPUR GEAR	
15	VF16516679	1	DRUM/REEL	
16	VF06578868	4	WASHER/DISC/PLATE	
17	VF16614454	4	RAKE	
18	VF16516664	1	SUPPORT PLATE	
19	VF01137321	2	RING	
20	VF01141159	2	ROLLER BEARING	
21	VF06273763	8	HEX. SCREW M12X60 I4014 8.8 A3C H2091	
22	VF06273771	8	HEX. SCREW M16X30 I4017 8.8 A3C H2091	
23	VF01112687	8	HEX. HEAD SCREW	
24	VF01142796	8	HEX.BOLT	
25	VF01127856	8	LOCK NUT	
26	VF01157381	4	DOWEL PIN	
27	VF01120696	2	GREASE NIPPLE H2 BM 6X1 DIN 71412	
28	VF16516754	1	RUBBER GROMMET	
29	VF01116946	4	BALL	
30	VF06273759	4	HEX. HEAD SCREW	
31	VF01142841	4	LOCKING WASHER	

Alpex 280 / DRUM ELEVATOR DRUM 3- RAKE

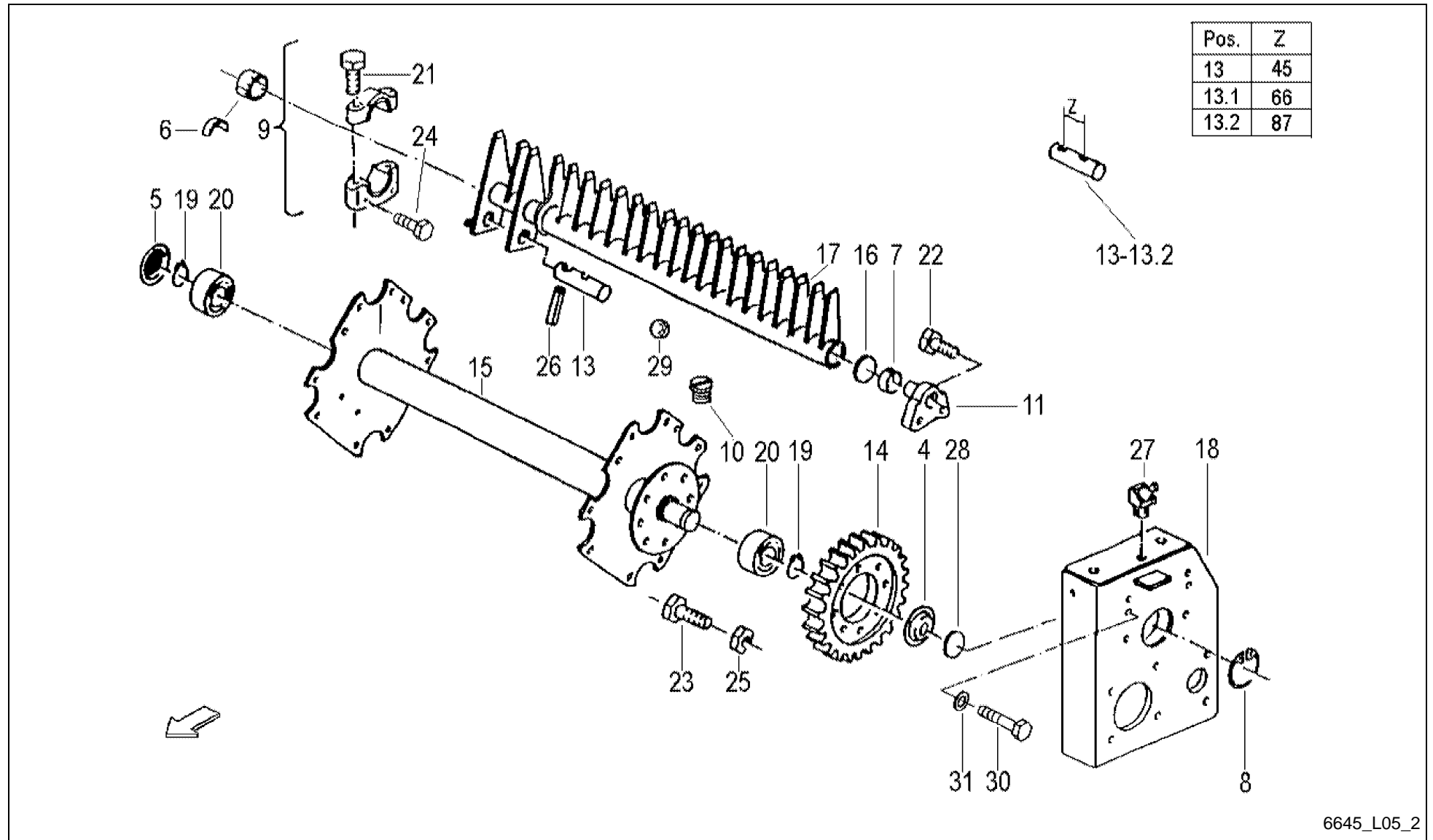

Alpex 280 / DRUM ELEVATOR DRUM 3- RAKE



PosNo.	Part No.	Qty.	Description	Remark
4	VF16516663	1	COVER	
5	VF06577317	1	CAP	
6	VF16515167	12	BEARING BRASS	
7	VF01142086	3	BUSH	
8	VF01107858	1	CIRCLIP	
9	VF16515168	3	BEARING/SUPPORT	
10	VF06216527	1	PROTECTING PLUG	
11	VF06571150	3	FLANGED PIN	
13	VF16516766	1	PIN/BOLT/STUD Z=45	
13.1	VF16516767	1	PIN/BOLT/STUD Z=66	
13.2	VF16516768	1	PIN/BOLT/STUD Z=87	
14	VF06577335	1	SPUR GEAR	
15	VF16631575	1	DRUM 3 FEEDER COMB	
16	VF06578868	3	WASHER/DISC/PLATE	
17	VF16614454	3	RAKE	
18	VF16516664	1	SUPPORT PLATE	
19	VF01137321	2	RING	
20	VF01141159	2	ROLLER BEARING	
21	VF06273763	6	HEX. SCREW M12X60 I4014 8.8 A3C H2091	
22	VF06273771	6	HEX. SCREW M16X30 I4017 8.8 A3C H2091	
23	VF01112687	6	HEX. HEAD SCREW	
24	VF01142796	6	HEX.BOLT	
25	VF01127856	6	LOCK NUT	
26	VF01157381	3	DOWEL PIN	
27	VF01120696	2	GREASE NIPPLE H2 BM 6X1 DIN 71412	
28	VF16516754	1	RUBBER GROMMET	
29	VF01116946	3	BALL	
30	VF06273759	4	HEX. HEAD SCREW	
31	VF01142841	4	LOCKING WASHER	

Alpex 280 / DRUM ELEVATOR CRANK WITH BEARING 4-RAKE

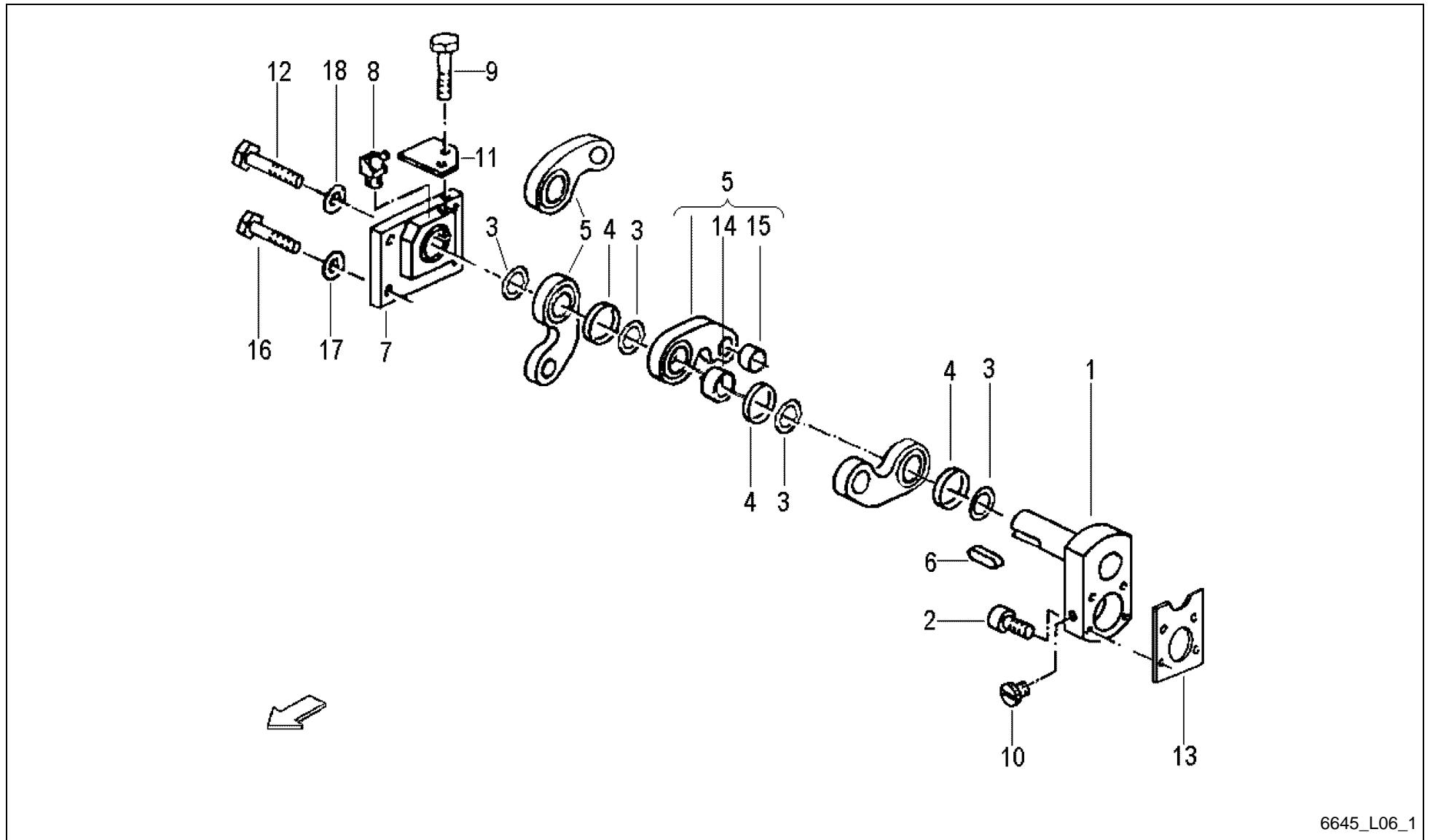

6645_L06_1

Alpex 280 / DRUM ELEVATOR CRANK WITH BEARING 4-RAKE



PosNo.	Part No.	Qty.	Description	Remark
1	VF06577374	1	CRANK BEARING	
2	VF06273756	4	SOCKET HEAD SCREW	
3	VF06273873	7	NEEDLE BEARING	
4	VF06587559	5	SEAL RING	
5	VF16516750	4	AXLE LINK	
6	VF06277509	2	SUNK KEY	
7	VF16516772	1	FLANGE	
8	VF01120697	1	GREASE NIPPLE H2 BM 8X1 DIN 71412	
9	VF06273759	4	HEX. HEAD SCREW	
10	VF06216527	1	PROTECTING PLUG	
11	VF06577328	1	PLATE	
12	VF01139339	1	HEX.BOLT	
13	VF06553944	1	COVER	
14	VF06277518	4	BUSH 70W75X20-Y1-N2-C	
15	VF06277517	4	BEARING BUSH	
16	VF01143090	4	HEX.BOLT	
17	VF01142841	8	LOCKING WASHER	
18	A143047563	1	SAFETYWASHER HS20	

Alpex 280 / DRUM ELEVATOR CRANK WITH BEARING 3-RAKE

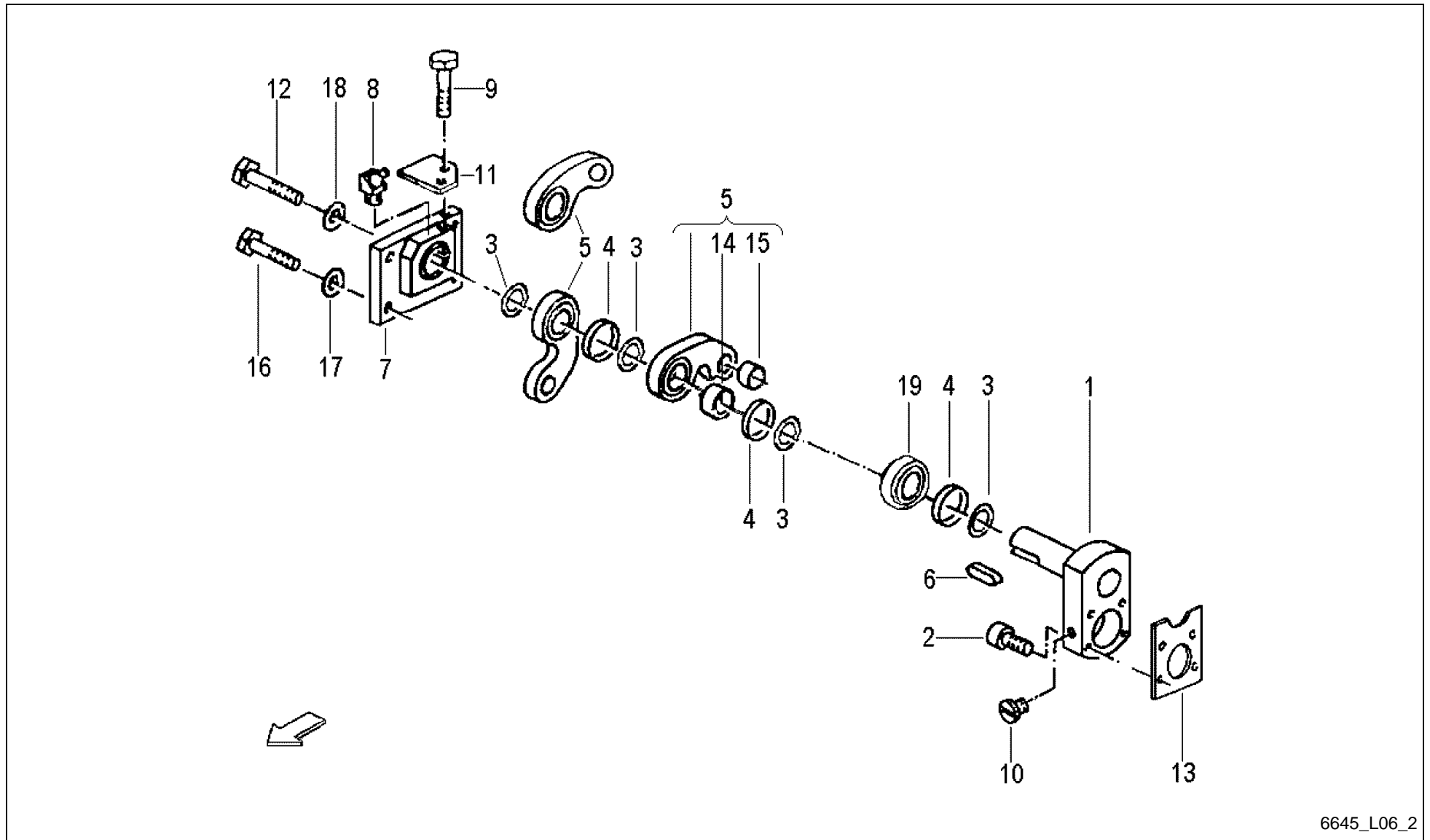

6645_L06_2

Alpex 280 / DRUM ELEVATOR CRANK WITH BEARING 3-RAKE



PosNo.	Part No.	Qty.	Description	Remark
1	VF06577374	1	CRANK BEARING	
2	VF06273756	4	SOCKET HEAD SCREW	
3	VF06273873	7	NEEDLE BEARING	
4	VF06587559	5	SEAL RING	
5	VF16516750	3	AXLE LINK	
6	VF06277509	2	SUNK KEY	
7	VF16516772	1	FLANGE	
8	VF01120697	1	GREASE NIPPLE H2 BM 8X1 DIN 71412	
9	VF06273759	4	HEX. HEAD SCREW	
10	VF06216527	1	PROTECTING PLUG	
11	VF06577328	1	PLATE	
12	VF01139339	1	HEX.BOLT	
13	VF06553944	1	COVER	
14	VF06277518	4	BUSH 70W75X20-Y1-N2-C	
15	VF06277517	3	BEARING BUSH	
16	VF01143090	4	HEX.BOLT	
17	VF01142841	8	LOCKING WASHER	
18	A143047563	1	SAFETYWASHER HS20	
19	VF16631687	1	FEEDER COMB RING COMPLETE -	

Alpex 280 / DRUM ELEVATOR PINION SHAFT

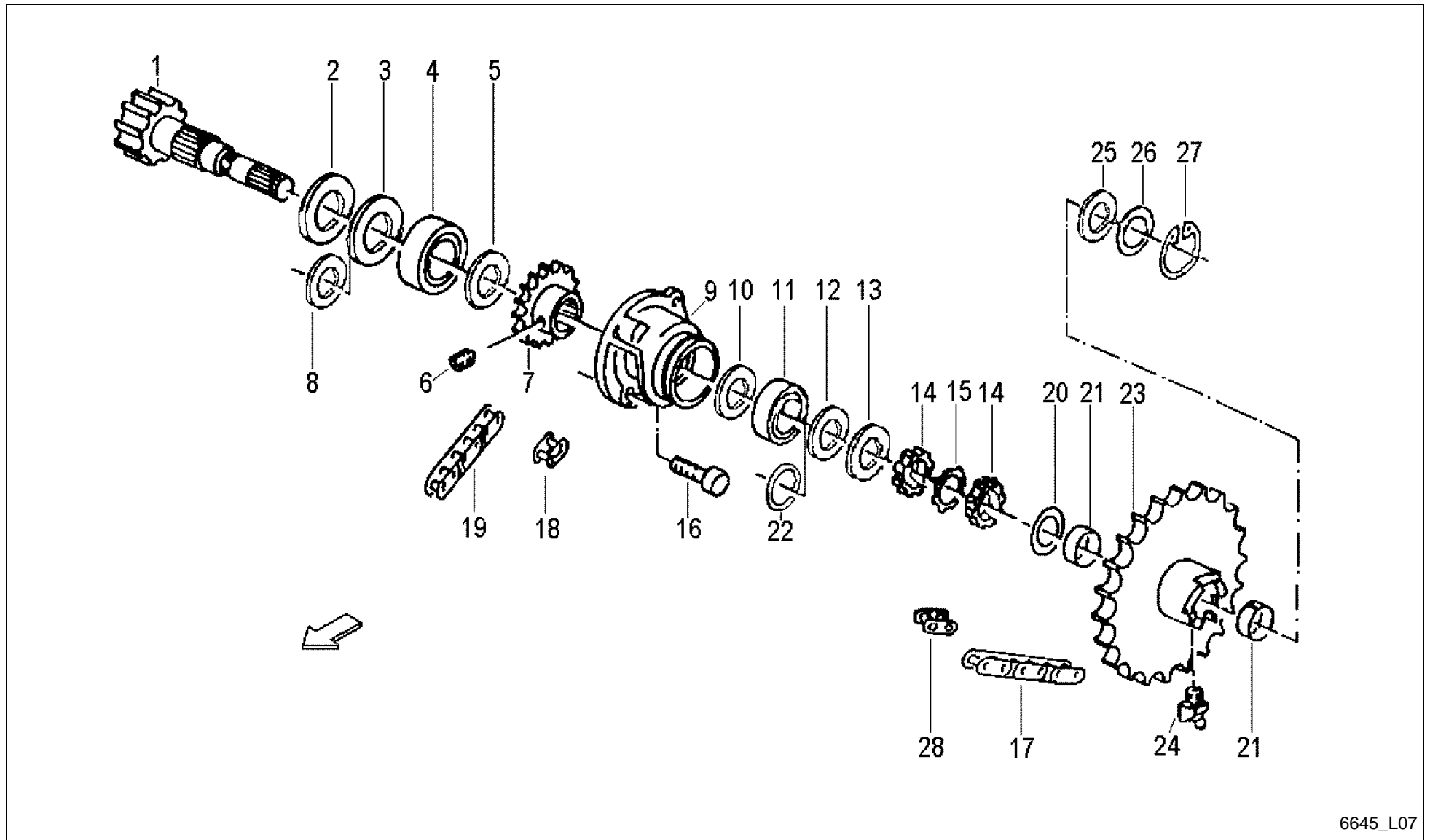

6645_L07



Alpex 280 / DRUM ELEVATOR PINION SHAFT

PosNo.	Part No.	Qty.	Description	Remark
1	VF06571032	1	PINION SHAFT	
2	VF06571205	1	SEALING WASHER	
3	VF06214950	1	NILOS RING	
4	VF01109962	1	TAPER R. BEARING	
5	VF06273872	1	NILOS RING	
6	VF06208934	1	FITTING DIN 914 M 10X16 10.9=32 HRC	
7	VF06570914	1	CHAIN SPROCKET 3/4" - Z=19	
8	VF01137990	1	SPACER 60X75X1,0 D988	
9	VF06577305	1	BEARING HOUSING	
10	VF06273871	1	NILOS RING	
11	VF01109960	1	TAPER R. BEARING	
12	VF06214948	1	NILOS RING	
13	VF06570007	1	SEALING WASHER	
14	VF01120613	2	GROOVED NUT	
15	VF01120671	1	LOCKING PLATE	
16	VF01175657	4	SCR.M16X40D912 8.8 GALV.DIN267-27MKL	
17	VF01142993.01	1	ROLLER CHAIN	
18	VF06213452		CHAIN-LOCKING-LINK	
19	A143015000	1	CHAIN 12B-1VX86E INCL. VGL	
20	VF06215016	1	THRUST WASHER AS 4565 45X65X1	
21	VF01139735	2	BUSH	
22	VF06214504	1	SPACER 50X62X1 D988	
23	VF06579358	1	HUB	
24	VF01120700	1	GREASE FITT. 90DEGR. H3 CM 8X1 DIN 71412	
25	VF06571033	1	RING	
26	VF06214500	1	WASHER 45X55X1,0 DIN 988	
26	VF06214499	1	SPACER 45X55X0,5 D988	
26	VF01137130	1	SHIM 45X55X3 DIN988-2	
27	VF01124663	1	CIRCLIP	
28	VF01397747		CHAIN LOCK	

Alpex 280 / DRUM ELEVATOR RELEASE LEVER

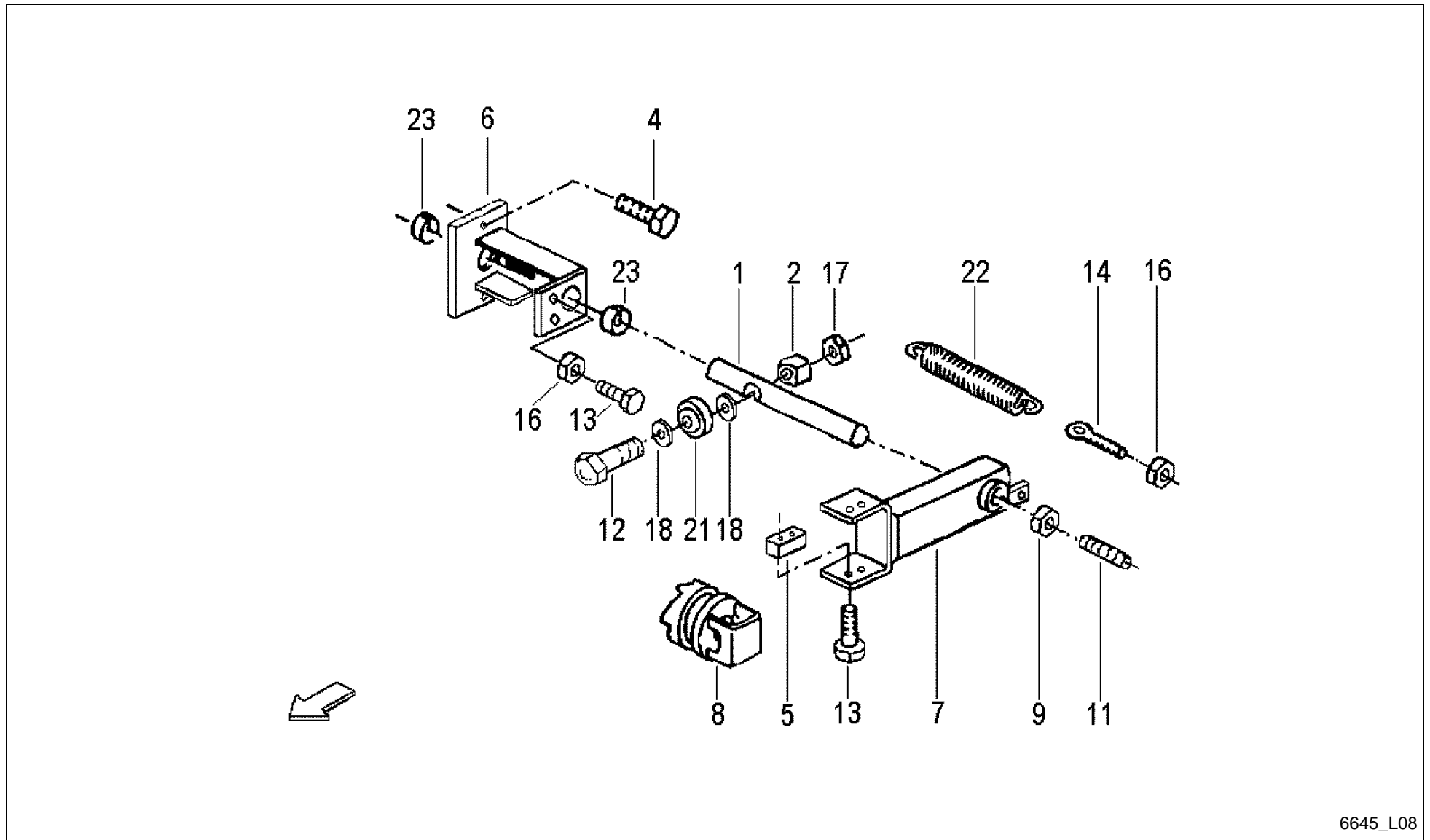

6645_L08

Alpex 280 / DRUM ELEVATOR RELEASE LEVER



PosNo.	Part No.	Qty.	Description	Remark
1	VF06577348	1	PIN	
2	VF06577349	1	GUIDE PIECE	
4	VF06277504	2	HEX. HEAD SCREW	
5	VF06587560	2	SLIDE PIECE	
6	VF16630386	1	SUPPORT, WELDED	
7	VF06577385	1	DISCONN.FORK	
8	VF06556728	1	SLIDE CLATCH	
9	VF01137252	1	HEXNUT	
11	VF06208962	1	THREADED PIN	
12	KG00358261	1	HEX. BOLT M12X90 8.8	
13	VF01112333	6	HEX. HEAD SCREW	
14	VF01138951	1	EYE BOLT LBM 8X 50 DIN 444 - 4.6	
16	VF01112824	3	HEX. NUT	
17	VF06209778	1	LOCK NUT	
18	VF06214207	3	WASHER	
21	VF06215029	1	ROLLER LR 201 KRRU AH 01 12X35X15	
22	VF06215561	1	TENSION SPRING	
23	VF06277514	2	BUSH	

Alpex 280 / PROTECTIVE COVERING

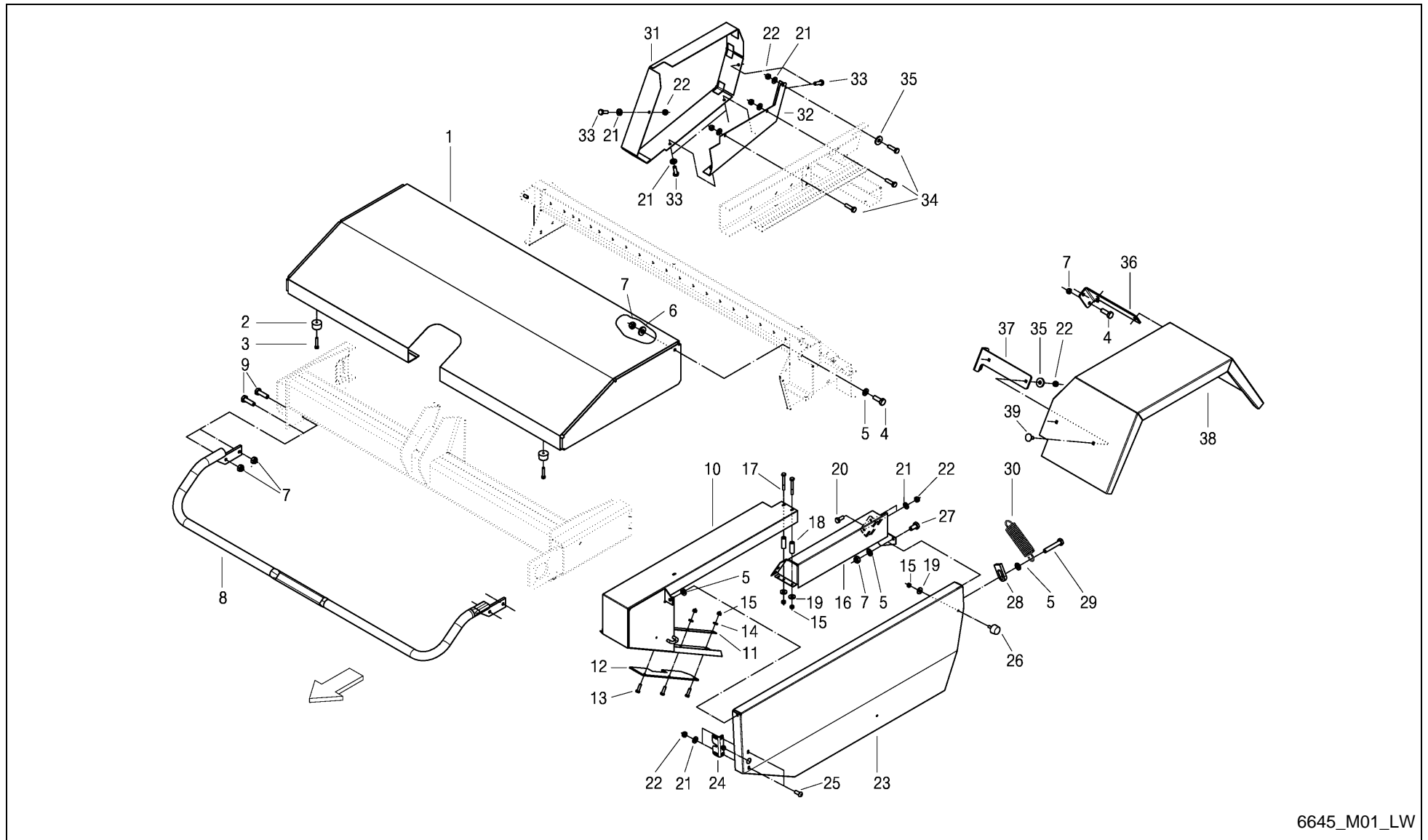

6645_M01_LW



Alpex 280 / PROTECTIVE COVERING

PosNo.	Part No.	Qty.	Description	Remark
1	A143029394	1	PROTECTION COVER WELDED	
2	VF01141112	2	RUBBER PAD	
3	VF01126049	2	SCREW	
4	VF01112429	10	HEX. HEAD SCREW	
5	VF01107165	5	WASHER M10 11X20X2 A2C DIN126	
6	VF16631676	2	WASHER 25/11/3	
7	VF06209768	13	LOCK NUT	
8	VF16611431	1	PROTECTIVE YOKE	
9	VF01112439	4	HEX. HEAD SCREW	
10	VF16611458	1	JACKET PLATE	
11	VF16611398	1	STRIP	
12	VF16611397	1	RUBBER STRIP	
13	VF01112264	3	HEX. HEAD SCREW	
14	VF01107095	3	WASHER 6,4DIN125 GALV.	
15	VF01114357	6	LOCK NUT	
16	A143029494	1	COVERING SHEET WELDED	
17	VF01111079	2	HEX.BOLT	
18	VF16518913	2	PIPE/TUBE	
19	VF06214189	3	WASHER 6,4X18X2 A2C	
20	VF01112322	2	HEX. HEAD SCREW	
21	VF06214358	10	WASHER	
22	VF01104944	16	NY LOCK NUT 8A3CD985	
23	A143025294	1	PROTECTION COVER	
24	VF16611457	1	LOCK	
25	VF01142565	2	TRUSS-HEAD SCR. M8X20 109 GALV.	
26	VF01142826	1	RUBBER PAD	
27	VF01112407	1	HEX. HEAD SCREW	
28	VF16630586	1	LIMIT STOP	
29	VF01111319	1	HEX.BOLT	
30	VF16613359	1	TENSION SPRING	
31	VF16631661	1	PROTECTIVE COVERING WELDED	
32	VF16631664	1	ANGLE WELDED	
33	VF01112333	4	HEX. HEAD SCREW	
34	VF01112341	3	HEX. HEAD SCREW	
35	VF06214192	9	WASHER 8,4X25X3 GALV.	
36	A143047686	2	SUPPORT, LEFT	
37	A143047786	2	SUPPORT, RIGHT	
38	A143047886	2	FENDER	
39	VF06207534	8	SCREW	

Alpex 280 / EQUIPMENT WITH 4 KNIVES ADJUSTMENT

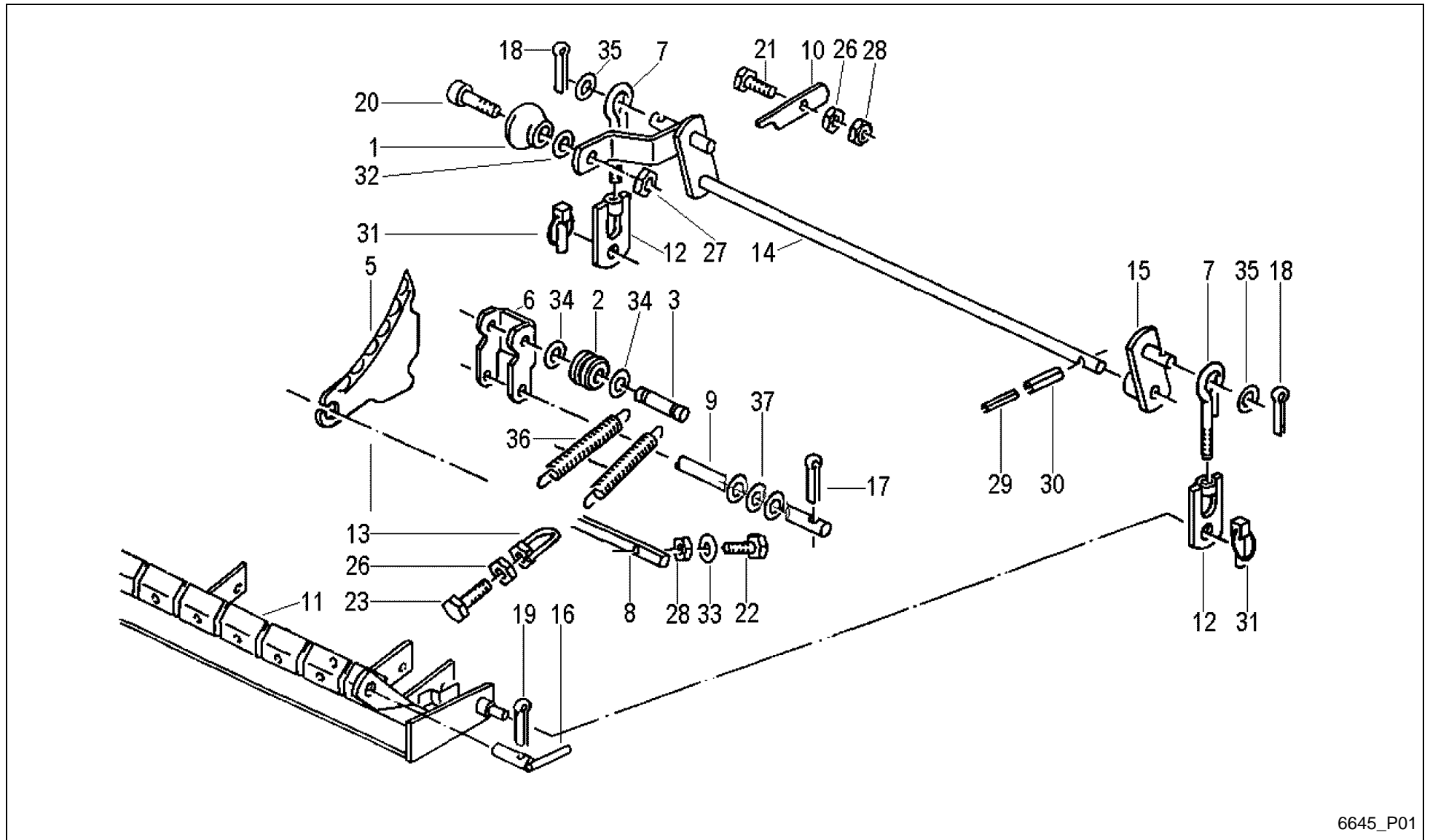

6645_P01



Alpex 280 / EQUIPMENT WITH 4 KNIVES ADJUSTMENT

PosNo.	Part No.	Qty.	Description	Remark
1	VF06243750	1	BALL	
2	VF06577109	4	ROLLER	
3	VF06577110	4	PIN	
5	VF06278720	4	KNIFE	
6	VF06577442	4	YOKE	
7	VF06577483	2	EYEBOLT	
8	VF16511337	1	KNIFE AXLE	
9	VF06577586	1	AXLE	
10	VF06577489	1	FLAT CATCH	
11	VF16631744	1	CUTTING UNIT SUPPORT	
12	VF06577494	2	TRACTION EYE	
13	VF06577496	8	NUT	
14	VF06570195	1	TORSION ROD	
15	VF06570185	1	LEVER	
16	VF06577498	2	FIXING PIN	
17	VF01106451	6	SPLIT PIN	
18	VF01122072	2	SPLIT PIN	
19	VF01143009	2	SPLIT PIN	
20	VF01101405	1	SCREW	
21	VF01112429	1	HEX. HEAD SCREW	
22	VF01112439	15	HEX. HEAD SCREW	
23	VF01112451	8	HEX. HEAD SCREW	
26	VF01102659	9	HEX. NUT	
27	VF01104944	1	NY LOCK NUT 8A3CD985	
28	VF06209768	16	LOCK NUT	
29	VF01157344	1	DOWEL PIN	
30	VF01138412	1	DOWEL PIN	
31	VF01126332	2	DOWEL PIN	
32	VF01138374	1	WASHER	
33	VF01107165	15	WASHER M10 11X20X2 A2C DIN126	
34	VF06214206	8	WASHER 13X30X4 RM=580-680 MPA A2C	
35	VF06214226	2	WASHER	
36	VF06215561	8	TENSION SPRING	
37	VF06214217	3	WASHER 17X28X3DIN1441 GALV.	

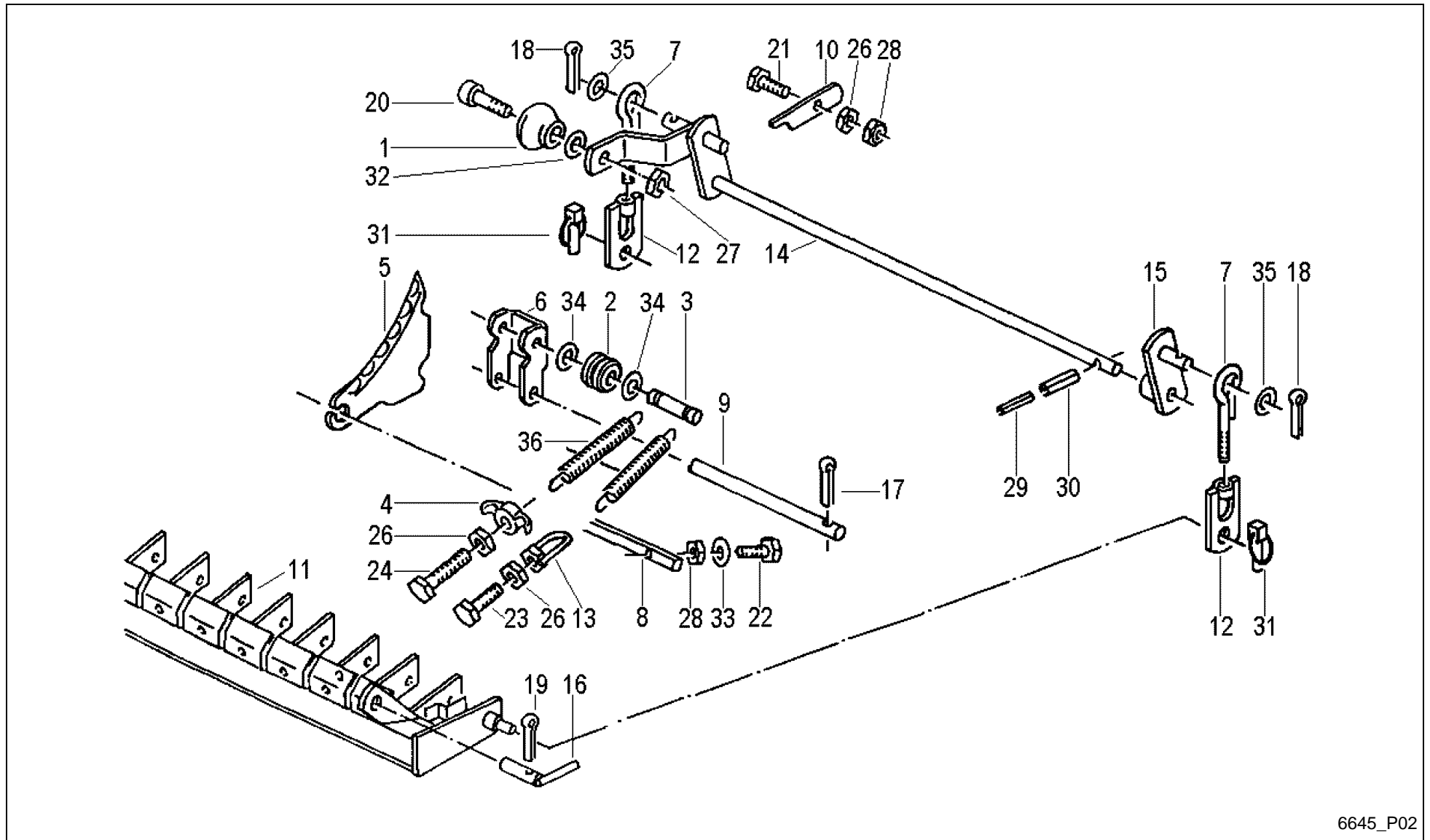



Alpex 280 / DOUBLE-CHOP EQUIPM.

PosNo.	Part No.	Qty.	Description	Remark
1	VF06243750	1	BALL	
2	VF06577109	16	ROLLER	
3	VF06577110	16	PIN	
4	VF06577111	15	TIGHTENING PLATE	
5	VF06278720	16	KNIFE	
6	VF06577442	16	YOKE	
7	VF06577483	2	EYEBOLT	
8	VF16511337	1	KNIFE AXLE	
9	VF06577586	1	AXLE	
10	VF06577489	1	FLAT CATCH	
11	A143047986	1	SUPPORT	
12	VF06577494	2	TRACTION EYE	
13	VF06577496	2	NUT	
14	VF06570195	1	TORSION ROD	
15	VF06570185	1	LEVER	
16	VF06577498	2	FIXING PIN	
17	VF01106451	16	SPLIT PIN	
18	VF01122072	2	SPLIT PIN	
19	VF01143009	2	SPLIT PIN	
20	VF01101405	1	SCREW	
21	VF01112429	1	HEX. HEAD SCREW	
22	VF01112439	15	HEX. HEAD SCREW	
23	VF01112451	2	HEX. HEAD SCREW	
24	VF01112476	15	HEX. HEAD SCREW	
26	VF01102659	18	HEX. NUT	
27	VF01104944	1	NY LOCK NUT 8A3CD985	
28	VF06209768	16	LOCK NUT	
29	VF01157344	1	DOWEL PIN	
30	VF01138412	1	DOWEL PIN	
31	VF01126332	2	DOWEL PIN	
32	VF01138374	1	WASHER	
33	VF01107165	15	WASHER M10 11X20X2 A2C DIN126	
34	VF06214206	32	WASHER 13X30X4 RM=580-680 MPA A2C	
35	VF06214226	2	WASHER	
36	VF06215561	32	TENSION SPRING	

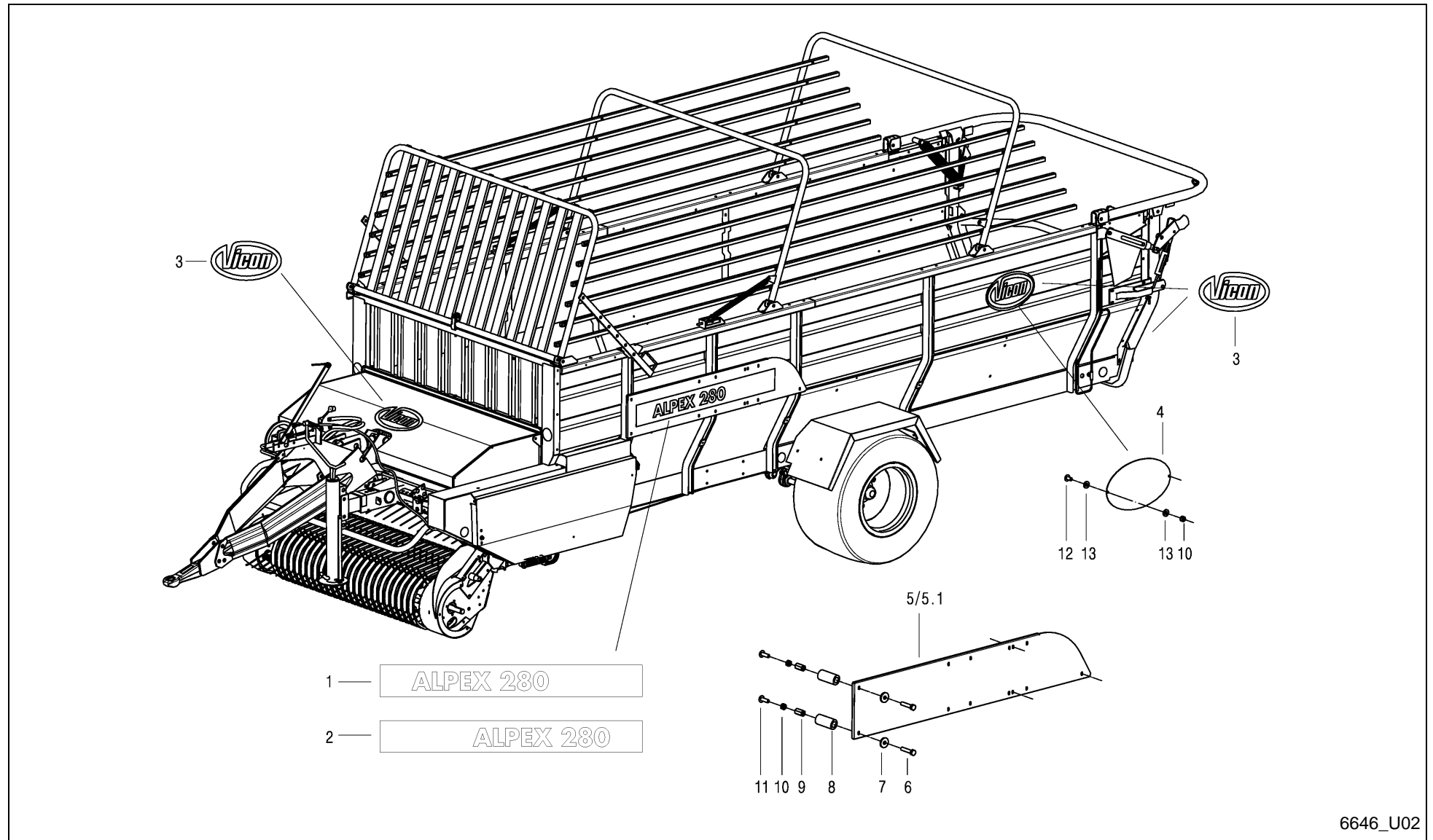

Alpex 280 / DECALS (+A 2015)



PosNo.	Part No.	Qty.	Description	Remark
1	A143017774	1	STICKER ALPEX 280 LEFT	
2	A143017874	1	STICKER ALPEX 280 RIGHT	
3	A143008974	4	STICKER VICON LOGO (MEDIUM-SIZED)	
4	A143009094	2	FITTING PANEL VICON_1	
5	A143017094	1	SHEET 1 LEFT	
5.1	A143017194	1	SHEET 2 RIGHT	
6	VF01112356	10	BOLT M8X40 ISO4017 8.8 A3C (D933)	
7	VF06214192	10	WASHER 8,4X25X3 GALV.	
8	A143017286	10	SPACER TUBE	
9	A143017300	10	EXTENSION NUT	
10	VF01104944	12	NY LOCK NUT 8A3CD985	
11	VF01142856	10	CUP SQR. BOLT M8X25DIN7380-2 10.9 GALV.	
12	VF01141006	2	TRUSS-HEAD SCR. M8X16 109 GALV.	
13	VF06214358	2	WASHER	

Alpex 280 / WARNING DECAL EU

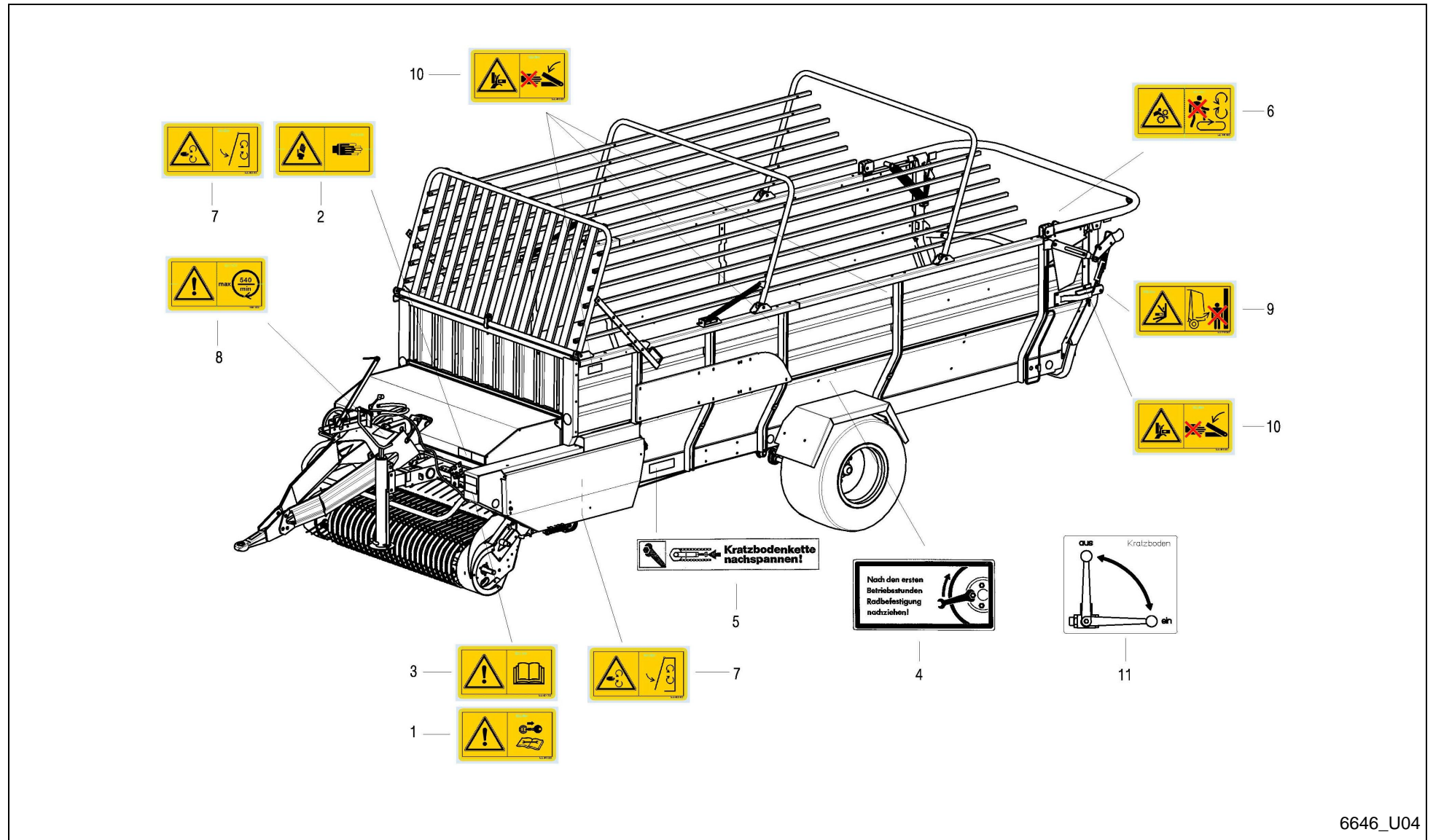

6646_U04

Alpex 280 / WARNING DECAL EU



PosNo.	Part No.	Qty.	Description	Remark
1	VF16601350	1	WARNING DECAL SWITCH OF THE ENGINE	
3	VF16613392	1	WARNING PLATE	
4	VF16613391	1	WARNING DECAL READ OPENING MANUAL	
5	VF06216097	1	MARKING PLATE	
6	A143019674	1	STICKER CHAIN TIGHTEN	
7	VF16613390	2	WARNING PLATE	
8	VF16613728	3	WARNSCHILD	
9	VF16601375	1	WARNING DECAL MAX. 540 RPM	
10	VF16613389	1	AUFKLEBER WARNSCHILD .	
11	VF16613719	8	WARNING DECAL RISK OF CRUSHING	
12	A143019774	1	STICKER HANDLING SCRAPER FLOOR	

Alpex 280 / Part No Index



Part No.	Page	Pos No	Part No.	Page	Pos No	Part No.	Page	Pos No	Part No.	Page	Pos No
A10000300	4	14	A143030294	26	10	A143484600	12	10	A143518000	38	472
A132715530	41	30	A143030394	26	11	A143484600	13	10	A143518100	38	424
A143008974	65	3	A143030430	48	1	A143485300	38	438	A143518200	38	425
A143009094	65	4	A143039600	22	29	A143488500	11	1	A143518300	38	433
A143009986	53	33	A143039600	22	29	A143493400	12	13	A143518400	38	435
A143014200	10	1	A143043200	30	2	A143493400	13	13	A143518500	38	436
A143014300	10	2	A143043400	23	5	A143493500	12	14	A143518600	38	440
A143015000	44	33	A143043500	23	6	A143493500	13	14	A143518700	38	442
A143015000	60	19	A143043600	23	7	A143493600	12	15	A143518800	38	446
A143017094	65	5	A143043700	23	8	A143493600	13	15	A143518900	38	447
A143017194	65	5.1	A143043800	23	9	A143493700	12	16	A143519000	38	449
A143017286	65	8	A143043900	23	10	A143493700	13	16	A143519100	38	470
A143017300	65	9	A143044000	23	12	A143493800	12	19	A143519200	38	471
A143017774	65	1	A143045286	41	31	A143493800	13	19	KG00358261	61	12
A143017874	65	2	A143046200	21	5	A143501400	20	23.2	KG00476561	4	13
A143018800	16	43	A143046463	22	28	A143502000	4	16	KG00480461	1	15
A143018986	46	40	A143047286	55	20	A143502100	3	13	KG00742063	3	52
A143019674	66	6	A143047563	58	18	A143503300	11	53	KG00742063	4	52
A143019774	66	12	A143047563	59	18	A143503800	11	96	KG01185862	8	5
A143023286	27	40	A143047686	62	36	A143504600	11	61	KG01194500	3	27
A143025294	62	23	A143047786	62	37	A143505100	11	62	KG01194500	4	27
A143028394	26	1	A143047886	62	38	A143507700	11	32	KG01273861	19	1
A143028694	26	4	A143047986	64	11	A143507800	11	43	KG01273861	50	45
A143029294	27	44	A143466900	38	437	A143507900	11	44	VF01097625	37	21
A143029394	62	1	A143466900	38	450	A143508000	11	59	VF01100590	5	4
A143029494	62	16	A143467500	38	451	A143508100	11	86	VF01100590	33	19
A143029594	26	2	A143472600	12	12	A143517100	38	473	VF01100590	34	19
A143029694	26	3	A143472600	13	12	A143517400	38	400	VF01100590	37	22
A143029794	26	5	A143472600	38	448	A143517500	38	414	VF01100600	12	2
A143029894	26	6	A143476100	12	20	A143517600	38	414A	VF01100600	13	2
A143029994	26	7	A143476100	13	20	A143517700	38	416	VF01100982	23	30
A143030094	26	8	A143476900	12	11	A143517800	38	417	VF01100982	24	30
A143030194	26	9	A143476900	13	11	A143517900	38	422	VF01101405	63	20

Alpex 280 / Part No Index



Part No.	Page	Pos No	Part No.	Page	Pos No	Part No.	Page	Pos No	Part No.	Page	Pos No
VF01101405	64	20	VF01104944	55	23	VF01107163	18	32	VF01108982	44	21
VF01101600	39	17.1	VF01104944	62	22	VF01107163	43	27	VF01109063	2	14
VF01102550	41	5	VF01104944	63	27	VF01107163	49	26	VF01109886	8	13
VF01102659	27	27	VF01104944	64	27	VF01107163	54	18	VF01109958	2	15
VF01102659	28	23	VF01104944	65	10	VF01107165	7	1	VF01109960	60	11
VF01102659	63	26	VF01105524	41	7	VF01107165	45	12	VF01109962	60	4
VF01102659	64	26	VF01105526	41	11	VF01107165	46	38	VF01110002	2	16
VF01102664	21	35	VF01105544	43	13	VF01107165	50	38	VF01110415	2	17
VF01102796	41	12	VF01105571	40	35	VF01107165	53	35	VF01110577	43	14
VF01102797	23	3	VF01106447	22	20	VF01107165	54	24	VF01111071	7	17
VF01102797	24	3	VF01106451	6	18	VF01107165	55	13	VF01111071	42	4
VF01102799	2	29	VF01106451	12	23	VF01107165	62	5	VF01111079	62	17
VF01102799	43	28	VF01106451	13	23	VF01107165	63	33	VF01111136	49	21
VF01102800	2	23	VF01106451	19	7	VF01107165	64	33	VF01111145	9	2
VF01102800	55	17	VF01106451	20	29	VF01107726	44	18	VF01111168	5	9
VF01103316	41	16	VF01106451	22	12	VF01107726	48	14	VF01111168	18	33
VF01104944	5	11	VF01106451	27	3	VF01107727	9	22	VF01111184	44	26
VF01104944	9	4	VF01106451	28	14	VF01107737	1	6	VF01111184	48	7
VF01104944	25	22	VF01106451	63	17	VF01107742	44	19	VF01111288	43	16
VF01104944	26	17	VF01106451	64	17	VF01107742	48	19	VF01111298	46	36
VF01104944	27	36	VF01106474	9	20	VF01107755	1	28	VF01111315	25	23
VF01104944	33	11	VF01106500	15	16	VF01107755	16	63	VF01111315	26	21
VF01104944	34	11	VF01106500	36	12	VF01107760	44	20	VF01111315	50	36
VF01104944	37	11	VF01107095	19	24	VF01107792	46	63	VF01111319	62	29
VF01104944	43	23	VF01107095	41	14	VF01107792	50	63	VF01111504	7	20
VF01104944	44	45	VF01107095	42	5	VF01107838	47	4	VF01111514	27	5
VF01104944	45	13	VF01107095	62	14	VF01107838	51	4	VF01111527	27	22
VF01104944	45	7	VF01107103	17	19	VF01107855	2	13	VF01111557	1	13
VF01104944	47	7	VF01107103	25	24	VF01107858	56	8	VF01111867	5	2
VF01104944	48	29	VF01107103	26	20	VF01107858	57	8	VF01111867	33	10
VF01104944	51	7	VF01107103	28	25	VF01108524	45	16	VF01111867	34	10
VF01104944	52	8	VF01107121	20	28	VF01108524	47	12	VF01111867	37	10
VF01104944	54	17	VF01107158	42	16	VF01108524	51	12	VF01112240	39	25

Alpex 280 / Part No Index



Part No.	Page	Pos No	Part No.	Page	Pos No	Part No.	Page	Pos No	Part No.	Page	Pos No
VF01112264	19	19	VF01112418	43	21	VF01112687	56	23	VF01115457	9	17
VF01112264	41	26	VF01112418	49	13	VF01112687	57	23	VF01115457	46	10
VF01112264	43	18	VF01112429	2	18	VF01112803	41	13	VF01115457	50	10
VF01112264	49	28	VF01112429	6	14	VF01112824	8	8	VF01115460	46	3
VF01112264	62	13	VF01112429	25	26	VF01112824	18	22	VF01115478	31	17
VF01112307	2	26	VF01112429	46	20	VF01112824	22	22	VF01115478	32	17
VF01112307	8	7	VF01112429	49	17	VF01112824	31	14	VF01115478	33	14
VF01112307	31	11	VF01112429	50	20	VF01112824	32	14	VF01115478	34	14
VF01112307	32	11	VF01112429	53	15	VF01112824	49	41	VF01115478	37	14
VF01112307	43	32	VF01112429	53	34	VF01112824	61	16	VF01115478	53	22
VF01112307	49	35	VF01112429	54	5	VF01112886	1	16	VF01116626	21	37
VF01112322	43	31	VF01112429	62	4	VF01112886	55	11	VF01116705	19	18
VF01112322	54	19	VF01112429	63	21	VF01112916	53	13	VF01116705	20	2
VF01112322	62	20	VF01112429	64	21	VF01112972	35	1	VF01116708	12	6
VF01112333	27	41	VF01112439	7	2	VF01112972	36	1	VF01116708	13	6
VF01112333	33	7	VF01112439	62	9	VF01114357	7	18	VF01116710	16	44
VF01112333	34	7	VF01112439	63	22	VF01114357	16	56	VF01116731	19	13
VF01112333	37	7	VF01112439	64	22	VF01114357	19	22	VF01116740	22	21
VF01112333	46	43	VF01112451	49	33	VF01114357	20	17	VF01116758	16	37
VF01112333	50	43	VF01112451	63	23	VF01114357	21	26	VF01116946	56	29
VF01112333	61	13	VF01112451	64	23	VF01114357	41	15	VF01116946	57	29
VF01112333	62	33	VF01112476	64	24	VF01114357	41	28	VF01118100	53	23
VF01112341	41	32	VF01112529	1	33	VF01114357	42	17	VF01118645	39	26
VF01112341	62	34	VF01112529	6	2	VF01114357	43	22	VF01118675	18	25
VF01112356	65	6	VF01112538	1	38	VF01114357	49	30	VF01120613	60	14
VF01112407	55	7	VF01112538	16	60	VF01114357	55	15	VF01120671	60	15
VF01112407	62	27	VF01112538	25	15	VF01114357	62	15	VF01120692	27	47
VF01112418	17	18	VF01112538	54	12	VF01115021	27	21	VF01120692	31	25
VF01112418	22	11	VF01112683	37	9	VF01115438	35	11	VF01120692	32	25
VF01112418	25	29	VF01112687	31	12	VF01115438	36	11	VF01120692	53	24
VF01112418	33	8	VF01112687	32	12	VF01115441	43	15	VF01120693	8	11
VF01112418	34	8	VF01112687	33	9	VF01115441	49	38	VF01120693	9	9
VF01112418	37	8	VF01112687	34	9	VF01115457	8	14	VF01120693	23	26

Alpex 280 / Part No Index



Part No.	Page	Pos No	Part No.	Page	Pos No	Part No.	Page	Pos No	Part No.	Page	Pos No
VF01120693	24	26	VF01124663	60	27	VF01135950	41	6	VF01138412	63	30
VF01120693	53	37	VF01124703	46	27	VF01136666	32	10	VF01138412	64	30
VF01120696	56	27	VF01124703	50	27	VF01136686	6	11	VF01138686	44	36
VF01120696	57	27	VF01125146	21	17	VF01136686	7	5	VF01138917	53	17
VF01120697	58	8	VF01125152	21	38	VF01136687	7	4	VF01138951	49	40
VF01120697	59	8	VF01126049	62	3	VF01136762	47	3	VF01138951	61	14
VF01120700	60	24	VF01126332	63	31	VF01136762	51	3	VF01138989	55	6
VF01121330	39	14	VF01126332	64	31	VF01136763	44	22	VF01139169	6	10
VF01121766	21	44	VF01127346	18	31	VF01136930	15	20	VF01139169	7	6
VF01121824	14	9	VF01127538	45	15	VF01136930	36	7	VF01139339	8	18
VF01121824	15	9	VF01127538	46	19	VF01137130	60	26	VF01139339	9	30
VF01121824	17	7	VF01127538	47	11	VF01137252	61	9	VF01139339	58	12
VF01121824	20	32	VF01127538	49	19	VF01137321	2	11	VF01139339	59	12
VF01121824	22	17	VF01127538	50	19	VF01137321	56	19	VF01139468	22	15
VF01121829	7	19	VF01127538	51	11	VF01137321	57	19	VF01139468	27	10
VF01122072	20	24	VF01127538	54	6	VF01137379	1	29	VF01139468	28	11
VF01122072	27	15	VF01127856	8	21	VF01137379	2	20.3	VF01139735	60	21
VF01122072	63	18	VF01127856	9	35	VF01137526	31	20	VF01141006	25	33
VF01122072	64	18	VF01127856	31	15	VF01137526	32	20	VF01141006	65	12
VF01122389	16	55	VF01127856	32	15	VF01137526	33	15	VF01141047	8	10
VF01122389	21	25	VF01127856	33	13	VF01137526	34	15	VF01141112	49	24
VF01122389	23	2	VF01127856	34	13	VF01137526	37	15	VF01141112	62	2
VF01122389	24	2	VF01127856	37	13	VF01137624	25	32	VF01141159	56	20
VF01123863	46	12	VF01127856	56	25	VF01137628	45	6	VF01141159	57	20
VF01123863	50	12	VF01127856	57	25	VF01137628	47	6	VF01141295	14	3
VF01123941	14	8	VF01128192	40	42	VF01137628	51	6	VF01141295	15	3
VF01123941	15	8	VF01128272	1	35	VF01137633	16	40	VF01141296	14	2
VF01123941	17	6	VF01131116	22	2	VF01137837	7	7	VF01141296	15	2
VF01123941	20	31	VF01132294	42	14	VF01137990	60	8	VF01141364	46	24
VF01123941	22	10	VF01132621	27	30	VF01138374	44	34	VF01141364	50	24
VF01124633	12	3	VF01132647	14	17	VF01138374	48	6	VF01141365	46	26
VF01124633	13	3	VF01132647	35	9	VF01138374	63	32	VF01141365	50	26
VF01124633	27	33	VF01133922	16	38	VF01138374	64	32	VF01141575	18	30

Alpex 280 / Part No Index



Part No.	Page	Pos No	Part No.	Page	Pos No	Part No.	Page	Pos No	Part No.	Page	Pos No
VF01141654	19	11	VF01142889	39	18	VF01163589	23	25	VF01397747	60	28
VF01142006	16	35	VF01142958	52	2	VF01163589	24	25	VF01397760	23	24
VF01142077	20	16	VF01142993.01	1	18	VF01164017	39	12	VF01397760	24	24
VF01142083	21	43	VF01142993.01	60	17	VF01167577	50	28	VF01397770	16	32
VF01142086	56	7	VF01143009	14	16	VF01169436	42	18	VF01397843	6	16
VF01142086	57	7	VF01143009	35	10	VF01169581	18	28	VF01397843	12	22
VF01142213	49	16	VF01143009	63	19	VF01169581	22	25	VF01397843	13	22
VF01142247	21	32	VF01143009	64	19	VF01169697	55	10	VF01397855	42	8
VF01142492	1	17	VF01143090	58	16	VF01172407	2	19	VF01397863	44	28
VF01142492	28	24	VF01143090	59	16	VF01172986	20	7	VF01397863	48	8
VF01142556	2	32	VF01143097	39	5	VF01172986	22	9	VF01397870	41	21
VF01142556	33	18	VF01143103	18	21	VF01173381	44	25	VF01397871	41	22
VF01142556	34	18	VF01143104	18	24	VF01173381	49	34	VF01397896	39	19
VF01142556	37	18	VF01143104	20	13	VF01173381	52	6	VF01397896	40	8
VF01142565	25	20	VF01143104	22	4	VF01173914	46	15	VF01397920	39	20
VF01142565	26	15	VF01151892	39	16	VF01173914	49	18	VF01397920	40	20
VF01142565	27	35	VF01151892	40	16	VF01173914	50	15	VF01397931	45	14
VF01142565	54	16	VF01157325	9	7	VF01175657	60	16	VF01397931	47	10
VF01142565	55	21	VF01157337	53	21	VF01177810	2	31	VF01397931	51	10
VF01142565	62	25	VF01157338	46	13	VF01177888	2	33	VF01397933	23	27
VF01142641	14	7	VF01157338	50	13	VF01177888	55	9	VF01397933	24	27
VF01142641	15	7	VF01157344	46	11	VF01178250	47	17	VF01403239	39	21
VF01142796	56	24	VF01157344	50	11	VF01178250	51	17	VF01404321	40	46
VF01142796	57	24	VF01157344	63	29	VF01292484	23	31	VF02953340	44	23
VF01142805	45	5	VF01157344	64	29	VF01292484	24	31	VF02953369	21	36
VF01142806	45	3	VF01157345	15	19	VF01397550	39	4	VF02953408	40	34
VF01142826	62	26	VF01157345	36	8	VF01397555	15	14	VF02953409	40	32
VF01142841	56	31	VF01157348	44	29	VF01397597	36	14	VF02953410	40	41
VF01142841	57	31	VF01157348	48	16	VF01397598	40	50	VF03.110.02.140	11	60
VF01142841	58	17	VF01157381	56	26	VF01397609	45	9	VF03.178.50.41	12	18
VF01142841	59	17	VF01157381	57	26	VF01397609	47	9	VF03.178.50.41	13	18
VF01142856	25	28	VF01157382	44	30	VF01397609	51	9	VF04308511	41	9
VF01142856	65	11	VF01157382	48	15	VF01397704	40	33	VF05.397.26.03	12	17

Alpex 280 / Part No Index



Part No.	Page	Pos No	Part No.	Page	Pos No	Part No.	Page	Pos No	Part No.	Page	Pos No
VF05.397.26.03	13	17	VF06209768	34	12	VF06212426	44	31	VF06214207	1	36
VF05.444.50.12	12	21	VF06209768	37	12	VF06212426	48	22	VF06214207	6	3
VF05.444.50.12	13	21	VF06209768	43	24	VF06212435	44	32	VF06214207	16	58
VF06207534	25	19	VF06209768	46	21	VF06213452	60	18	VF06214207	25	17
VF06207534	26	18	VF06209768	46	39	VF06213664	36	15	VF06214207	27	7
VF06207534	62	39	VF06209768	49	14	VF06213737	39	15	VF06214207	61	18
VF06207535	25	27	VF06209768	50	21	VF06213973	41	4	VF06214215	27	4
VF06207535	45	11	VF06209768	50	39	VF06213974	42	10	VF06214217	63	37
VF06207557	55	14	VF06209768	53	18	VF06213977	41	2	VF06214218	27	9
VF06208913	44	24	VF06209768	53	36	VF06214041	41	20	VF06214226	31	24
VF06208913	48	21	VF06209768	54	7	VF06214156	16	53	VF06214226	32	24
VF06208934	60	6	VF06209768	55	12	VF06214189	21	27	VF06214226	46	5
VF06208962	61	11	VF06209768	62	7	VF06214189	41	27	VF06214226	63	35
VF06209165	31	10	VF06209768	63	28	VF06214189	43	26	VF06214226	64	35
VF06209245	55	18	VF06209768	64	28	VF06214189	49	29	VF06214234	46	4
VF06209411	53	14	VF06209769	1	34	VF06214189	55	16	VF06214236	9	21
VF06209459	25	31	VF06209769	6	4	VF06214189	62	19	VF06214237	15	17
VF06209459	55	8	VF06209769	7	21	VF06214192	5	10	VF06214238	15	21
VF06209473	31	13	VF06209769	16	59	VF06214192	25	21	VF06214238	36	9
VF06209473	32	13	VF06209769	25	18	VF06214192	26	16	VF06214246	2	28
VF06209476	43	19	VF06209769	27	6	VF06214192	27	37	VF06214295	5	3
VF06209476	49	22	VF06209769	54	14	VF06214192	62	35	VF06214295	22	13
VF06209765	41	8	VF06209774	8	17	VF06214192	65	7	VF06214295	28	13
VF06209765	42	15	VF06209774	9	29	VF06214193	52	7	VF06214306	16	39
VF06209768	6	15	VF06209774	31	16	VF06214193	55	22	VF06214307	21	46
VF06209768	7	8	VF06209774	32	16	VF06214197	7	9	VF06214313	44	44
VF06209768	17	20	VF06209778	61	17	VF06214198	55	24	VF06214313	47	14
VF06209768	22	16	VF06210014	22	19	VF06214202	6	17	VF06214313	48	32
VF06209768	25	25	VF06210032	27	2	VF06214202	17	5	VF06214313	51	14
VF06209768	26	19	VF06210033	46	8	VF06214202	20	33	VF06214314	44	43
VF06209768	27	38	VF06210033	50	8	VF06214206	54	13	VF06214314	48	31
VF06209768	28	28	VF06211876	31	23	VF06214206	63	34	VF06214332	16	64
VF06209768	33	12	VF06211876	32	23	VF06214206	64	34	VF06214332	53	26

Alpex 280 / Part No Index



Part No.	Page	Pos No	Part No.	Page	Pos No	Part No.	Page	Pos No	Part No.	Page	Pos No
VF06214333	16	65	VF06215016	60	20	VF06216479	40	22	VF06273763	57	21
VF06214333	53	26.1	VF06215027	44	38	VF06216479	41	23	VF06273771	56	22
VF06214358	9	3	VF06215027	48	13	VF06216479	42	12	VF06273771	57	22
VF06214358	62	21	VF06215029	61	21	VF06216480	42	13	VF06273854	43	25
VF06214358	65	13	VF06215308	46	37	VF06216527	23	21	VF06273854	49	15
VF06214420	48	25	VF06215308	50	37	VF06216527	24	21	VF06273871	60	10
VF06214470	9	23	VF06215315	27	18	VF06216527	56	10	VF06273872	60	5
VF06214481	44	36	VF06215425	19	3	VF06216527	57	10	VF06273873	58	3
VF06214481	48	20	VF06215561	43	29	VF06216527	58	10	VF06273873	59	3
VF06214486	31	21	VF06215561	49	39	VF06216527	59	10	VF06277296	21	16
VF06214486	32	21	VF06215561	61	22	VF06216757	21	42	VF06277504	46	41
VF06214486	33	16	VF06215561	63	36	VF06216763	21	45	VF06277504	50	41
VF06214486	34	16	VF06215561	64	36	VF06216771	21	3	VF06277504	61	4
VF06214486	37	16	VF06215666	45	18	VF06216772	21	4	VF06277509	58	6
VF06214490	2	20	VF06215666	46	22	VF06216815	23	23	VF06277509	59	6
VF06214490	44	35	VF06215666	47	13	VF06216815	24	23	VF06277510	53	25
VF06214491	2	20.1	VF06215666	50	22	VF06216836	16	51	VF06277514	61	23
VF06214492	2	20.2	VF06215666	51	13	VF06216854	23	17	VF06277516	44	41
VF06214493	1	31	VF06215671	8	22	VF06216854	24	17	VF06277516	48	26.2
VF06214499	60	26	VF06215785	1	25	VF06216908	12	4	VF06277517	58	15
VF06214500	60	26	VF06216097	66	5	VF06216908	13	4	VF06277517	59	15
VF06214504	60	22	VF06216396	20	20	VF06243750	63	1	VF06277518	58	14
VF06214519	2	21.2	VF06216396	21	47	VF06243750	64	1	VF06277518	59	14
VF06214520	2	21.1	VF06216396	42	7	VF06246795	44	4	VF06278720	63	5
VF06214521	2	21	VF06216397	14	13	VF06246795	48	10.1	VF06278720	64	5
VF06214570	44	46	VF06216397	15	13	VF06251677	53	38	VF06282196	44	2
VF06214572	44	46	VF06216397	19	21	VF06273756	58	2	VF06295430	2	8
VF06214585	19	6	VF06216397	20	15	VF06273756	59	2	VF06296264	43	2
VF06214588	1	5	VF06216397	22	27	VF06273759	56	30	VF06296264	49	6
VF06214633	28	10	VF06216397	40	48	VF06273759	57	30	VF06296285	44	5
VF06214938	44	37	VF06216401	22	7	VF06273759	58	9	VF06296285	48	4
VF06214948	60	12	VF06216479	17	14	VF06273759	59	9	VF06301830	44	3
VF06214950	60	3	VF06216479	39	22	VF06273763	56	21	VF06550287	53	28

Alpex 280 / Part No Index



Part No.	Page	Pos No	Part No.	Page	Pos No	Part No.	Page	Pos No	Part No.	Page	Pos No
VF06550405	1	37	VF06558562	31	7	VF06571032	60	1	VF06576830	50	16
VF06552906	54	9	VF06558562	32	7	VF06571033	60	25	VF06577030	53	11
VF06553944	58	13	VF06558565	37	4	VF06571090	43	12	VF06577063	53	2
VF06553944	59	13	VF06558567	33	5	VF06571099	43	11	VF06577064	53	3
VF06554188	2	6	VF06558567	34	5	VF06571134	43	3	VF06577109	63	2
VF06554513	31	1	VF06558567	37	5	VF06571148	44	42	VF06577109	64	2
VF06554525	32	3	VF06558568	41	19	VF06571150	56	11	VF06577110	63	3
VF06554536	35	2	VF06558569	31	8	VF06571150	57	11	VF06577110	64	3
VF06554540	35	3	VF06558569	32	8	VF06571196	55	3	VF06577111	64	4
VF06554569	14	14	VF06558706	7	10	VF06571205	60	2	VF06577220	53	8
VF06554569	35	6	VF06558708	7	11	VF06571309	44	10	VF06577305	60	9
VF06554571	14	21	VF06558728	7	13	VF06571309	48	9.1	VF06577317	56	5
VF06554790	31	19	VF06558801	21	33	VF06571314	44	40	VF06577317	57	5
VF06554790	32	19	VF06558937	55	1	VF06571314	48	27	VF06577328	58	11
VF06554790	33	1	VF06559137	7	3	VF06571321	44	11	VF06577328	59	11
VF06554790	34	1	VF06559221	43	10	VF06571322	43	4	VF06577335	56	14
VF06554790	37	1	VF06559244	44	14	VF06571322	49	31	VF06577335	57	14
VF06554794	33	2	VF06562350	22	5	VF06571323	43	6	VF06577348	61	1
VF06554794	37	2	VF06564448	36	13	VF06571323	49	32	VF06577349	61	2
VF06556268	33	3	VF06564733	46	1	VF06571325	55	19	VF06577374	58	1
VF06556268	34	3	VF06564733	50	1	VF06571330	16	29	VF06577374	59	1
VF06556728	61	8	VF06564735	46	25	VF06571341	16	36	VF06577385	61	7
VF06556744	46	23	VF06564735	50	25	VF06571341	17	13	VF06577387	50	40
VF06556744	50	23	VF06567492	46	28	VF06571355	43	30	VF06577389	55	4
VF06556888	1	39	VF06567492	50	30	VF06575227	2	34	VF06577391	55	5
VF06557587	2	10	VF06567493	46	29	VF06575227	33	6	VF06577397	44	6
VF06557740	3	56	VF06570007	60	13	VF06575227	34	6	VF06577406	44	8
VF06558198	46	35	VF06570185	63	15	VF06575227	37	6	VF06577407	44	9
VF06558198	50	35	VF06570185	64	15	VF06575248	2	30	VF06577420	46	18
VF06558560	31	5	VF06570195	63	14	VF06575249	2	30.1	VF06577420	50	18
VF06558560	32	5	VF06570195	64	14	VF06575250	2	30.2	VF06577421	46	17
VF06558561	31	6	VF06570914	60	7	VF06576503	19	4	VF06577421	50	17
VF06558561	32	6	VF06571004	44	7	VF06576830	46	16	VF06577422	46	14

Alpex 280 / Part No Index



Part No.	Page	Pos No	Part No.	Page	Pos No	Part No.	Page	Pos No	Part No.	Page	Pos No
VF06577422	50	14	VF06579961	39	17	VF06587631	7	15	VF16513948	16	34
VF06577423	45	10	VF06579979	39	10	VF0905191000	43	25.1	VF16514101	8	12
VF06577432	44	17	VF06579981	40	42	VF0905191000	49	15.1	VF16514101	9	10
VF06577432	48	26.1	VF06579982	40	42	VF11439109110	2	9	VF16514201	46	9
VF06577442	63	6	VF06580174	1	7	VF16504065	3	32	VF16514201	50	9
VF06577442	64	6	VF06580546	50	29	VF16504077	3	58	VF16514460	42	2
VF06577483	63	7	VF06581181	14	18	VF16504079	19	5	VF16514631	19	5
VF06577483	64	7	VF06581181	15	18	VF16511337	63	8	VF16515167	56	6
VF06577489	63	10	VF06581181	19	23	VF16511337	64	8	VF16515167	57	6
VF06577489	64	10	VF06581181	20	10	VF16511469	39	28	VF16515168	56	9
VF06577494	63	12	VF06581954	3	54	VF16511469	40	15	VF16515168	57	9
VF06577494	64	12	VF06581954	4	54	VF16512287	42	1	VF16515428	16	33
VF06577496	63	13	VF06582181	3	30	VF16512621	10	3	VF16515446	40	38
VF06577496	64	13	VF06582182	3	31	VF16513000	1	27	VF16515448	40	39
VF06577498	63	16	VF06582340	3	26	VF16513003	1	30	VF16515453	39	11
VF06577498	64	16	VF06582340	4	26	VF16513217	1	3	VF16515468	39	24
VF06577586	63	9	VF06582530	17	11	VF16513246	32	1	VF16515739	42	11
VF06577586	64	9	VF06585321	2	2	VF16513298	44	12	VF16515748	52	4
VF06577864	19	14	VF06586171	3	12	VF16513298	48	9	VF16515976	20	25
VF06577968	53	27	VF06586171	4	12	VF16513299	44	13	VF16515977	41	17
VF06577987	22	1	VF06586755	3	24	VF16513299	48	10	VF16515987	20	26
VF06578035	7	16	VF06586755	4	24	VF16513473	45	8	VF16516330	41	3
VF06578035	16	57	VF06587052	39	13	VF16513473	47	8	VF16516333	41	18
VF06578035	21	24	VF06587235	31	9	VF16513473	51	8	VF16516335	42	6
VF06578611	22	3	VF06587235	32	9	VF16513601	4	15	VF16516337	42	9
VF06578750	53	4	VF06587268	53	5	VF16513605	4	30	VF16516558	18	29
VF06578868	56	16	VF06587269	53	6	VF16513616	3	53	VF16516663	56	4
VF06578868	57	16	VF06587310	29	3	VF16513616	4	53	VF16516663	57	4
VF06578934	45	4	VF06587559	58	4	VF16513618	3	59	VF16516664	56	18
VF06578978	2	24	VF06587559	59	4	VF16513618	4	56	VF16516664	57	18
VF06579358	60	23	VF06587560	46	42	VF16513860	6	12	VF16516677	23	1
VF06579959	39	2	VF06587560	50	42	VF16513861	6	13	VF16516677	24	1
VF06579960	39	3	VF06587560	61	5	VF16513942	39	23	VF16516679	56	15

Alpex 280 / Part No Index



Part No.	Page	Pos No	Part No.	Page	Pos No	Part No.	Page	Pos No	Part No.	Page	Pos No
VF16516696	24	5	VF16516836	9	11	VF16611055	27	11	VF16611433	32	22
VF16516699	24	6	VF16517144	36	3	VF16611079	40	43	VF16611457	62	24
VF16516700	24	7	VF16517160	36	2	VF16611081	40	45	VF16611458	62	10
VF16516701	24	8	VF16517165	36	4	VF16611247	54	8	VF16611479	45	2
VF16516702	24	9	VF16517215	42	3	VF16611252	3	11	VF16611487	45	1
VF16516705	24	10	VF16517499	46	7	VF16611252	4	11	VF16611490	28	9
VF16516706	24	12	VF16517499	50	7	VF16611261	2	5	VF16612402	11	91
VF16516707	24	13	VF16517792	40	31	VF16611262	2	4	VF16612405	11	98
VF16516708	24	14	VF16517917	40	40	VF16611275	40	31	VF16612406	11	31
VF16516717	23	28	VF16517922	40	36	VF16611281	9	32	VF16613236	39	7
VF16516717	24	28	VF16517923	40	37	VF16611312	20	14	VF16613237	39	8
VF16516750	58	5	VF16518135	23	29	VF16611317	42	20	VF16613238	39	9
VF16516750	59	5	VF16518135	24	29	VF16611318	42	19	VF16613243	40	44
VF16516754	56	28	VF16518241	3	1	VF16611321	20	27	VF16613255	12	1
VF16516754	57	28	VF16518245	4	1	VF16611321	28	16	VF16613255	13	1
VF16516766	56	13	VF16518259	6	9	VF16611325	27	31	VF16613267	8	1
VF16516766	57	13	VF16518312	9	33	VF16611326	27	32	VF16613273	31	2.1
VF16516767	56	13.1	VF16518524	39	17.2	VF16611330	27	34	VF16613273	32	2.1
VF16516767	57	13.1	VF16518865	5	8	VF16611331	27	43	VF16613283	40	49
VF16516768	56	13.2	VF16518890	17	17	VF16611338	27	29	VF16613283	42	21
VF16516768	57	13.2	VF16518913	62	18	VF16611341	27	28	VF16613284	9	1
VF16516769	56	13.3	VF16518921	1	14	VF16611351	27	19	VF16613306	19	17
VF16516772	58	7	VF16518970	40	42	VF16611352	27	20	VF16613311	20	9
VF16516772	59	7	VF16519184	19	2	VF16611356	33	17	VF16613359	62	30
VF16516821	9	8	VF16601350	66	1	VF16611356	34	17	VF16613360	37	3
VF16516824	9	13	VF16601375	66	9	VF16611382	20	30	VF16613380	16	54
VF16516826	9	14	VF16602598	11	33	VF16611397	62	12	VF16613387	39	6
VF16516827	9	15	VF16610801	1	1	VF16611398	62	11	VF16613389	66	10
VF16516828	9	16	VF16610801	2	1	VF16611400	53	31	VF16613390	66	7
VF16516829	9	25	VF16610873	16	31	VF16611401	53	32	VF16613391	66	4
VF16516830	9	26	VF16610926	23	18	VF16611418	27	24	VF16613392	66	3
VF16516831	9	27	VF16610926	24	18	VF16611431	62	8	VF16613394	39	1
VF16516834	9	36	VF16611054	27	25	VF16611433	31	22	VF16613400	44	15

Alpex 280 / Part No Index



Part No.	Page	Pos No	Part No.	Page	Pos No	Part No.	Page	Pos No	Part No.	Page	Pos No
VF16613433	16	41	VF16614483	9	28	VF16630156	48	26	VF16630709	48	17
VF16613434	16	47	VF16614484	9	18	VF16630158	14	1	VF16630710	49	8
VF16613435	16	30	VF16614485	9	19	VF16630158	15	1	VF16630716	49	4
VF16613436	16	48	VF16614668	43	33	VF16630159	14	1.1	VF16630721	49	23
VF16613446	16	49	VF16614668	49	20	VF16630159	15	1.1	VF16630734	49	27
VF16613447	16	50	VF16615171	17	8	VF16630219	29	4	VF16630736	49	9
VF16613449	17	1	VF16615203	44	16	VF16630219	30	3	VF16630736.01	49	9.1
VF16613469	29	2	VF16615203	48	11	VF16630283	33	4	VF16630738	49	5
VF16613470	29	1	VF16617329.86	11	84	VF16630283	34	4	VF16630742	49	25
VF16613719	66	11	VF16617332	11	82A	VF16630386	61	6	VF16630743	48	23
VF16613728	66	8	VF16618602	11	93	VF16630398	37	3.1	VF16630744	48	30
VF16614169	1	26	VF16618603	11	94	VF16630398	38	1	VF16630745	49	37
VF16614454	56	17	VF16618604	11	95	VF16630486	18	23	VF16630746	49	12
VF16614454	57	17	VF16618627	11	54	VF16630486	22	26	VF16630757	27	13
VF16614457	38	410	VF16618629	11	73	VF16630488	6	8	VF16630766	48	24
VF16614458	38	415	VF16618697	11	29	VF16630548	8	20	VF16630767.01	48	33
VF16614459	38	421	VF16618715	48	12	VF16630548	9	34	VF16630768.01	48	33
VF16614460	38	423	VF16622598	46	30	VF16630549	31	4	VF16630900	16	52.1
VF16614461	38	431	VF16624941	11	82	VF16630586	62	28	VF16630966	44	27
VF16614464	38	413	VF16624942	11	40B	VF16630646	21	40	VF16630966	48	28
VF16614465	38	430	VF16624942	38	465	VF16630647	21	41	VF16630974	25	5
VF16614472	8	19	VF16625105	3	55	VF16630655	1	4	VF16630980	28	22
VF16614473	8	2	VF16625105	4	55	VF16630657	20	23.1	VF16630982	28	21
VF16614474	8	3	VF16625114	4	5	VF16630658	20	23	VF16631049	19	20
VF16614475	8	4	VF16625120	4	4	VF16630682	48	3	VF16631049	22	8
VF16614476	9	12	VF16630106	46	44	VF16630685	48	2	VF16631123	17	2
VF16614477	9	24	VF16630109	46	2	VF16630686	48	18	VF16631123	19	15
VF16614478	8	16	VF16630112	43	9	VF16630690	49	3	VF16631123	20	12
VF16614478	9	31	VF16630114	43	5	VF16630695	49	2	VF16631123	22	6
VF16614479	8	15	VF16630115	43	7	VF16630700	49	7	VF16631126	47	15
VF16614480	8	6	VF16630119	43	8	VF16630705	49	1	VF16631126	51	15
VF16614481	9	5	VF16630125	43	1	VF16630706	49	10	VF16631129	51	5
VF16614482	9	6	VF16630125	44	1	VF16630707	49	11	VF16631133	47	16

Alpex 280 / Part No Index



Part No.	Page	Pos No	Part No.	Page	Pos No	Part No.	Page	Pos No	Part No.	Page	Pos No
VF16631133	51	16	VF16631550	27	8	VF16631678	25	7	VF16631829	25	9
VF16631134	51	2	VF16631553	27	42	VF16631681	7	12	VF16631831	25	4
VF16631135	51	1	VF16631555	27	1	VF16631685	14	15	VF16631831	26	13
VF16631181	49	36	VF16631556	27	26	VF16631685	35	5	VF16631832	25	3
VF16631182	1	24	VF16631559	25	8	VF16631687	59	19	VF16631832	26	14
VF16631184	55	20.1	VF16631561	25	14	VF16631692	16	42	VF16631833	20	3
VF16631186	49	21.1	VF16631562	25	13	VF16631698	19	12	VF16631834	28	12
VF16631187	48	18.1	VF16631563	25	12	VF16631699	19	16	VF16631835	28	1
VF16631220	55	2	VF16631564	25	11	VF16631705	20	1	VF16631848	28	15
VF16631223	14	4	VF16631565	26	12	VF16631707	20	5	VF16631849	16	45
VF16631224	14	6	VF16631575	57	15	VF16631708	20	6	VF16631851	16	46
VF16631225	14	5	VF16631587	25	16	VF16631709	20	8	VF16631854	12	7
VF16631249	41	10	VF16631594	53	10	VF16631721	6	1	VF16631854	13	7
VF16631263	1	2	VF16631598	52	5	VF16631726	12	9	VF16631868	48	34
VF16631291	18	26	VF16631599	52	3	VF16631726	13	9	VF16631872	41	1
VF16631291	22	24	VF16631605	25	2	VF16631727	12	5	VF16631883	18	27
VF16631427	47	2	VF16631606	25	1	VF16631727	13	5	VF16631883	22	23
VF16631429	47	5	VF16631609	20	4	VF16631729	12	8	VF16631885	22	18
VF16631430	47	1	VF16631611	16	52	VF16631729	13	8	VF16631888	30	1
VF16631460	31	2	VF16631612	16	67	VF16631744	63	11	VF16631889	14	10
VF16631460	32	2	VF16631613	53	9	VF16631753	53	7	VF16631889	15	10
VF16631478	31	3	VF16631614	16	66	VF16631756	52	1	VF16631889	18	34
VF16631478	32	3.1	VF16631617	16	68	VF16631757	52	9	VF16631898	5	6
VF16631486	8	16.1	VF16631621	16	61	VF16631778	28	3	VF16631899	5	7
VF16631486	9	31.1	VF16631624	16	62	VF16631779	28	4	VF16631908	21	19
VF16631491	34	2	VF16631635	28	2	VF16631781	28	5	VF16631909	21	20
VF16631491	37	2.1	VF16631636	22	14	VF16631782	28	6	VF16631914	28	29
VF16631530	54	1	VF16631636	25	6	VF16631783	28	7	VF16635132	43	6.1
VF16631533	54	15	VF16631647	25	10	VF16631784	28	8	VF16635132	49	32.1
VF16631534	54	4	VF16631659	54	23	VF16631786	5	1	VF16635245	41	24
VF16631535	54	3	VF16631661	62	31	VF16631786	11	1	VF16635247	41	25
VF16631538	54	22	VF16631664	62	32	VF16631789	28	27	VF16635249	41	29
VF16631539	54	2	VF16631676	62	6	VF16631828	25	30	VF16635313	15	15



Alpex 280 / Part No Index

Part No.	Page	Pos No			
VF16635313	36	6			
VG35.06.70	3	23			
VG35.06.70	4	23			
VG63.12.01	3	25			
VG63.12.01	4	25			
VG85.01.02	4	51			
WA116192	3	5			
WA116565	3	4			
WA129948	3	51			
WA135075	3	21			
WA135075	4	21			
WA135895	3	28			
WA135895	4	28			
WA135897	3	29			
WA135897	4	29			
WA153207	3	22			
WA153207	4	22			
WA377342	3	57			



Alpex 280

0101 < Mach. ID <=

Maschinenfabrik Stolpen GmbH
Pirnaer Landstraße 24
D-01833 Stolpen
Germany
+49 35973 2240
+49 35973 22414

© Kverneland Group

All rights reserved. No parts of this book may be reproduced, stored in a database or retrieval system, or published in any form or in any way, electronically, mechanically, optically, by print, photo print, microfilm (including micro and macro fiche), or any other means, including all video and CD systems, without prior written permission from the publisher.

Print date: 2019-05-16

